

ALL DIMENSIONS ARE IN MM

REV 01	DATE 21.01.12	ALTERED S.KIRUBAHARAN
		CHECKED SSN.KUMAR
		APPROVED G.LOGANATHAN

DIMENSIONS Ø230,Ø226
 Ø216,20 & 13 WERE RESPECTIVELY
 Ø214,Ø209,Ø190,14.5 & 10
 REF. DRG NO.&ITEM DRG NO.WERE
 9-7-1155-15-00216 & 171

1.6/0.8/

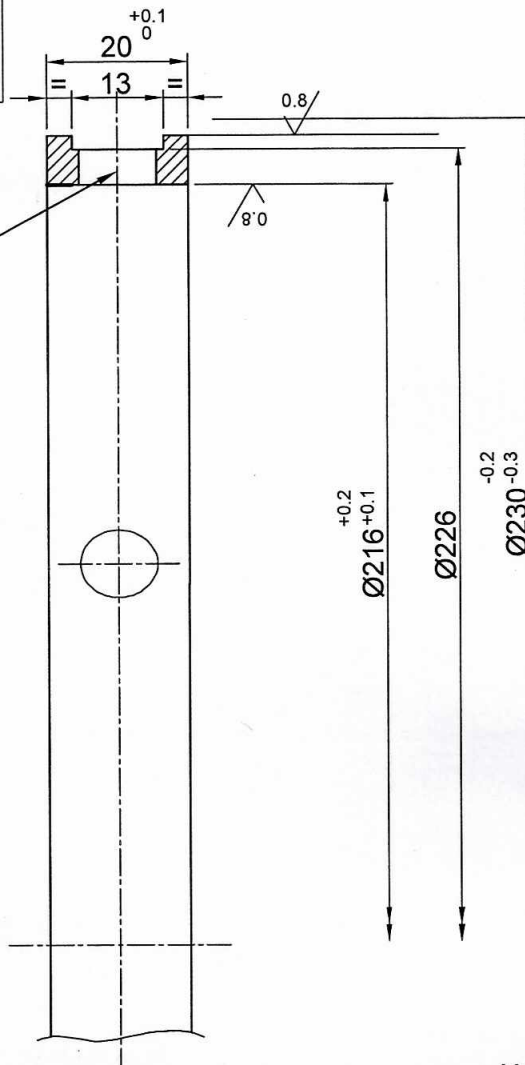

NOTE TO SHOP MTCE

ON RECEIPT WIDTH 20^{+0.1} TO BE GROUND TO MATCH THE ASSY

HARDEN TO HRC 60^{±2}

CAUTION: THE INFORMATION ON THIS DOCUMENT IS THE PROPERTY OF BHARAT HEAVY ELECTRICALS LIMITED.IT MUST NOT BE USED DIRECTLY OR INDIRECTLY IN ANY WAY DETRIMENTAL TO THE INTEREST OF THE COMPANY.

			103Cr1	IS:4398	
ITEM NO	DESCRIPTION	DRAWING NO	MATL CODE	UNIT WT	
			MATL SPEC	QTY	
EQPT: STRETCH REDUCING MILL					
 Bharat Heavy Electricals Ltd SEAMLESS STEEL TUBE PLANT TIRUCHIRAPALLI - 620014	DRN	NAME	SIGNATURE	DATE	
	CHD	B.ASHOKKUMAR	<i>B.ASHOKKUMAR</i>	22.02.03	
	APPD	SSN.KUMAR	<i>SSN.KUMAR</i>	21.03.03	
DEPT	GRADE OF UNTOL. DIM	SCALE	WEIGHT (Kg)	REF TO ASSY DWG NO	ITEM
SSTP	Ø/M/F	1:1	0.77	0-7-1155-15-11046	182
CODE	IS: 2102			REF TO OLD DWG NO	
TITLE	SRM - SPACER FOR BRG 30226J2/DF-GEAR BOX ASSY			DRAWING NO :	REV
	CARD CODE	4-7-1155-15-06207			01
	U 01				

A4-SIZE

FIRST ANGLE PROJECTION (ALL DIMENSIONS IN MILLIMETRES)

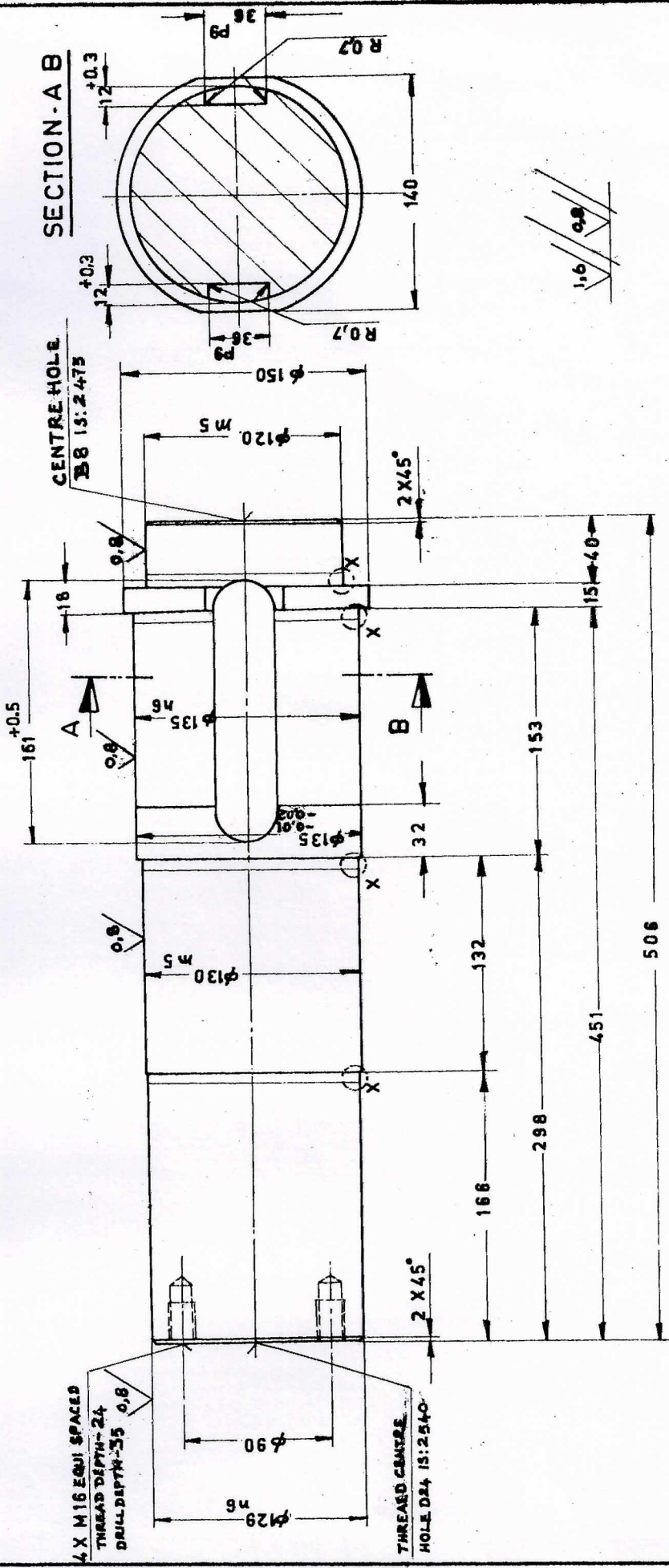

CAUTION THE INFORMATION ON THIS DOCUMENT IS THE PROPERTY OF BHARAT HEAVY ELECTRICALS LTD. IT MUST NOT BE USED DIRECTLY OR INDIRECTLY IN ANY WAY DETRIMENTAL TO THE INTEREST OF THE COMPANY.

ITEM NO.	DESCRIPTION	DRAWING NO.	MATL CODE	UNIT WT
			42 Cr 4 Mo 2	
			MATL SPEC	QTY
15.9817				
DEPT	SCALE	WEIGHT (N)	REF TO ASSY/OLD DING	REV
Bharat Heavy Electricals Ltd., SEAMLESS STEEL TUBE PLANT TRUCHIRAPPALLI - 620 014	1:2.5	53	2 8015	REV
DATE	APPROVED	DATE	SIGN	NO. OF
15.09.17	[Signature]	15.09.17	[Signature]	ITEMS
REV	ZONE	REV	DRAWING NO.	REV
129 h6		1	3-7-1155-15-00600	1
130 h5		2		
135 h6		3		
120 h5		4		
36 h9		5		

129 h6	+0,052
130 h5	+0,027
135 h6	+0,033
120 h5	+0,015
36 h9	+0,052
	+0,027
	+0,013
	-0,026
	-0,088

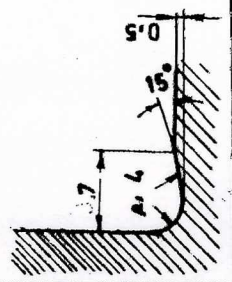

CAUTION THE INFORMATION ON THIS DOCUMENT IS THE PROPERTY OF BHARAT HEAVY ELECTRICALS LTD. IT MUST NOT BE USED DIRECTLY OR INDIRECTLY IN ANY WAY DETRIMENTAL TO THE INTEREST OF THE COMPANY.

FIRST ANGLE PROJECTION (ALL DIMENSIONS IN MILLIMETRES)

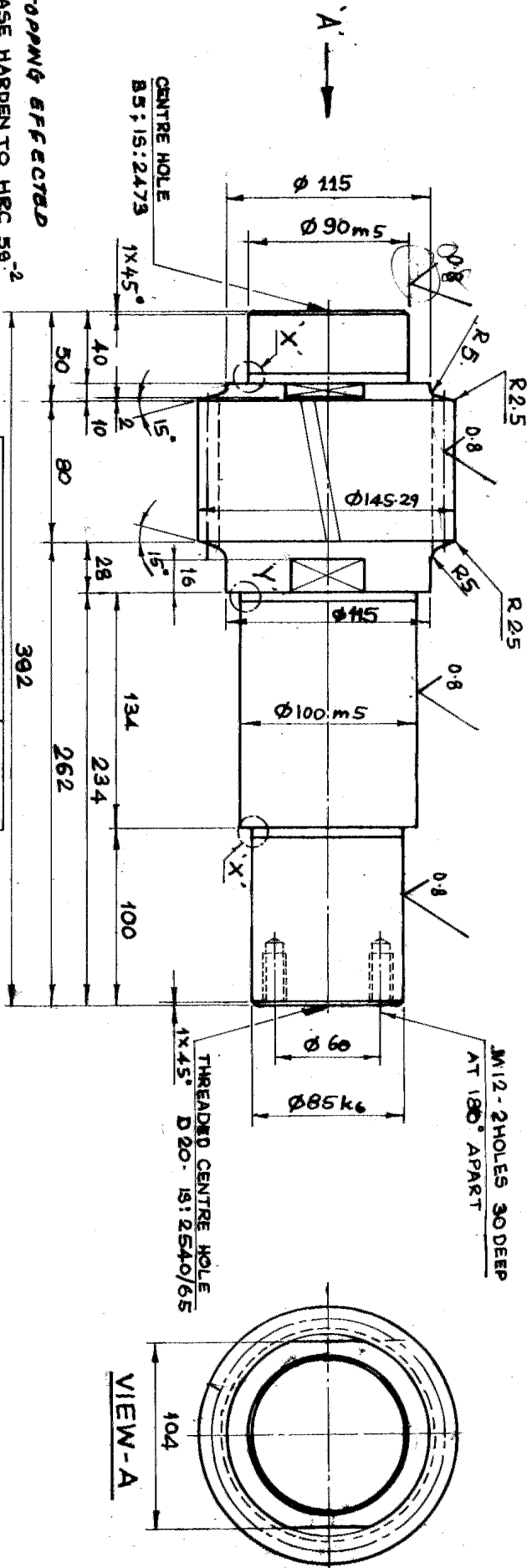

TOPPING EFFECTED
CASE HARDEN TO HRC 58-2
CASE DEPTH = 1.1MM

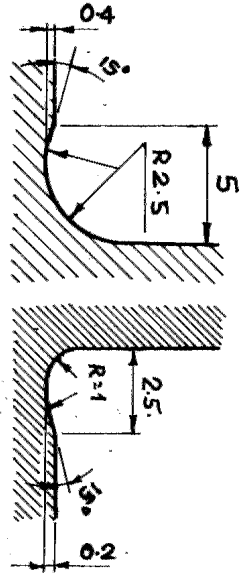

DETAIL-X **DETAIL-Y**

NO. OF TEETH	21 T
NORMAL MODULE	6
AXIAL MODULE	6.093
PRESSURE ANGLE	20°
HELIX ANGLE	10°
HAND OF HELIX	L/H
CORRECTION FACTOR	+0.55
WIDTH ACROSS 4 TEETH	66.095
GEAR RATIO	2.5
MATING GEAR NO. OF TEETH	52
MATING GEAR DRG. NO.	4-7-115-15-002A
CENTRE DISTANCE	225.5

REV	DATE	ALTERED BY	SCALE	GRADE OF UNTO, DIM	SCALE	WEIGHT (kg)	REF TO ASSEMBLY Dwg	ITEM NO.	
01	28-8-83	ASSEMBLY	1:2.5	C/M/F	1:2.5		29010		
MATERIAL SPECIFICATION		MATERIAL SPECIFICATION		MATERIAL SPECIFICATION		MATERIAL SPECIFICATION		MATERIAL SPECIFICATION	
MATERIAL SPEC. IS: 4482 WAS 17MND C1 95		MATERIAL SPEC. IS: 1570/61		MATERIAL SPEC. IS: 1570/61		MATERIAL SPEC. IS: 1570/61		MATERIAL SPEC. IS: 1570/61	
TITLE		TITLE		TITLE		TITLE		TITLE	
PINION SHAFT 2.21		PINION SHAFT 2.21		PINION SHAFT 2.21		PINION SHAFT 2.21		PINION SHAFT 2.21	
DEPT		DEPT		DEPT		DEPT		DEPT	
SHARAT HEAVY ELECTRICALS LTD.		SHARAT HEAVY ELECTRICALS LTD.		SHARAT HEAVY ELECTRICALS LTD.		SHARAT HEAVY ELECTRICALS LTD.		SHARAT HEAVY ELECTRICALS LTD.	
SEAMLESS STEEL TUBE PLANT		SEAMLESS STEEL TUBE PLANT		SEAMLESS STEEL TUBE PLANT		SEAMLESS STEEL TUBE PLANT		SEAMLESS STEEL TUBE PLANT	
TIRUCHIRAPPALLI - 620 014		TIRUCHIRAPPALLI - 620 014		TIRUCHIRAPPALLI - 620 014		TIRUCHIRAPPALLI - 620 014		TIRUCHIRAPPALLI - 620 014	
EQUIP: 5RM		EQUIP: 5RM		EQUIP: 5RM		EQUIP: 5RM		EQUIP: 5RM	
DESCRIPTION		DESCRIPTION		DESCRIPTION		DESCRIPTION		DESCRIPTION	
DRAWING NO.		DRAWING NO.		DRAWING NO.		DRAWING NO.		DRAWING NO.	
16MNC 4 15.440		16MNC 4 15.440		16MNC 4 15.440		16MNC 4 15.440		16MNC 4 15.440	
MATERIAL CODE		MATERIAL CODE		MATERIAL CODE		MATERIAL CODE		MATERIAL CODE	
UNIT WT		UNIT WT		UNIT WT		UNIT WT		UNIT WT	
MATERIAL SPEC		MATERIAL SPEC		MATERIAL SPEC		MATERIAL SPEC		MATERIAL SPEC	
QTY		QTY		QTY		QTY		QTY	
SIGN		SIGN		SIGN		SIGN		SIGN	
DATE		DATE		DATE		DATE		DATE	
22.01.83		22.01.83		22.01.83		22.01.83		22.01.83	

16 / 08

