



**ENQUIRY
(INDIGENOUS)**

BHARAT HEAVY ELECTRICALS LIMITED

(A Government of India Undertaking)
80, G.N.ROAD, T.NAGAR
Purchase Department - Piping Centre
CHENNAI - 600 017.
TAMILNADU (INDIA)

PHONE :
GRAMS : BHARATELEC
FAX NO :
E-mail :
Web :

OFFICE COPY	Collective No.	Enquiry Date	Due Date for Quotation
	4010700043	26.12.2007	09.01.2008 Due Date for
Please quote Enquiry No, Date and due date in all correspondences. This is only a request for quotation and not an order			
RFQ No: 4010700043			

Item	Description	Unit	Quantity	Delivery Quantity	Schedule Date
10	159385960000 PIPE DIA1626X14 OG (SPI/LONG) IS3589-410 <i>HTP: 26.00 TDC: TDG:07:05 Length: 10000.00</i>	M	50.000	50.00	31.03.08
20	159386000001 PIPE 1626 X16-OG 3589 FE 410 LS/SPIRAL <i>HTP: 30.00 TDC: TDG:07:05 Length: 10000.00</i>	M	10.000	10.00	31.03.08
30	1593859600UG PIPE DIA 1626X14(SPI/LONG)IS3589-410MPA <i>HTP: 26.00 TDC: TDG:07:05 Length: 10000.00</i>	M	100.000	100.00	31.03.08
40	1593859900UG PIPE DIA 2540 X 20 IS3589-410MPA-UG <i>HTP: 23.00 TDC: TDG:07:05 Length: 10000.00</i>	M	400.000	400.00	31.03.08
50	159386000UG1 PIPE 1626 X16 IS 3589 FE 410 LS/SPIRAL <i>HTP: TDG:07:05 TDC: TDG:07:05 Length: 10000.00</i>	M	120.000	120.00	31.03.08

General Note:

Enclosures:

"LD clause has to be confirmed without fail."

PR Links

Material.	PR.No	PR.Item.	Quantity	Acc. Assign	Customer Number

The offers should reach us before the time of opening of tenders.
The offers will be opened at 14:30 hours on the due date in the presence of the tenderers who may like to be present.
Late tenders are liable to be rejected.

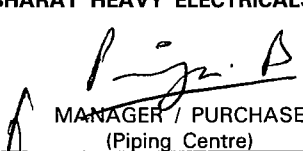
Yours faithfully,
For **BHARAT HEAVY ELECTRICALS LIMITED**

MANAGER / PURCHASE
(Piping Centre)

ENQUIRY NO: 4010700043
IMPORTANT INFORMATION TO BIDDERS.

DATE: 26.12.07

1. This Tender is a **TWO PART BID.**
Part I - Technical cum Commercial.
Part II - Price.
Type and quantum of work is detailed in "SCOPE OF WORK"
2. The quoted price shall be " FIRM " till the complete execution of the scope.
3. Last date for submission of offer **09.01.08 - Time - 13.30 Hours.**
4. Technical cum Commercial Bid Opening Date **09.01.08 - Time - 14.30 Hours.**
5. Price Bid of only the Technically acceptable offers shall be opened at a later date.
6. The above bid shall be sent in a sealed cover duly indicating

Enquiry No. & date, Tender Opening date and " CW PIPING - IS 3589 – RAYALSEEMA PROJECT"
To
SDGM / PROCUREMENT
BHEL - Piping Centre
Old No 93, (New No:80) G N Chetty Road
T Nagar / Chennai 600 017 . PHONE : 28158804 / 28158820

(Technical cum Commercial offer and Priced offer shall be put in separate envelopes with the above mentioned details on it.)

SCOPE OF WORK :

BHEL requires the below mentioned quantities of various sizes of Welded Pipes – Pipes either **Spiral or Longitudinal Seam Weld** conforming to IS 3589 FE 410 Pipes with Internal and External Painting and as per TDC-TDG:07:05 and to be delivered to Site as per Technical specification detailed out in Technical and Commercial Part of this Bid. The raw material plate is to be arranged by suppliers themselves.

LIST OF ITEMS.

Enq. Sl.no	Pipe Size	Sp. Length mm	Specification	Hydro Test (Bars)	Qty. Mtr	Destination	Delivery
01	Dia 1626 x14 OG	10000	IS 3589	26	50.0	RAYALSEEMA SITE	31.03.08
02	Dia 1626 x14 UG	10000	IS 3589	26	100.0	RAYALSEEMA SITE	31.03.08
03	Dia 2540 x20 UG	10000	IS 3589	23	400.0	RAYALSEEMA SITE	31.03.08
04	Dia 1626 x16 UG	10000	IS 3589	30	120.0	RAYALSEEMA SITE	31.03.08
05	Dia 1626 x16 OG	10000	IS 3589	30	10.0	RAYALSEEMA SITE	31.03.08

Total Weight = 661 MT

PART - I : TECHNICAL CUM COMMERCIAL.

Technical :

1. The bidder shall supply the Welded Pipes, as per IS 3589 Specification and shall also comply with the following BHEL documents.
 - a. Acceptance to BHEL TDC ref : TDG : 07 : 05 .
 - b. Painting requirements for CW Piping – APGENCO Rayalseema RTPP Stage III Unit -5, as per QP No. 6928 : QPC : 01 Rev 00 Dt. 5.12.07.05
 - c. Edge Preparation shall be done on each Pipe as per BHEL Drawing No. 4-80-468-58799 Rev 00
 - d. Spiders shall be provided as per the enclosed drawings

2. Bidders shall clearly indicate their point to point acceptance to the TDC and other requirements and in case, any deviations taken shall be clearly indicated. Also, Please ensure "Not to repeat deviations taken in earlier tenders which have not been accepted by BHEL". This will enable quicker processing of tender. Any deviations taken after placement of Purchase Order "shall not be considered". The bidder shall clearly mention the manufacturing process that will be adopted. Also the proposed WPS (Welding Procedure Specification) shall be enclosed.
3. The Bidder shall submit their Quality plan to BHEL for approval along with the offer indicating the verification, witness and hold points of PDIL and Customer Inspection with percentage of checks involved in the manufacturing process. The Procedure for the Holiday Detector Testing shall be submitted along with the offer. Holiday Test shall be witnessed by BHEL/BHEL Authorised agency and Customer.
4. The Bidder shall indicate the raw material specification of Plate/Coil to be used for Pipe Fabrication.
5. Vendors to depute suitable representative to discuss and finalise Technical and Commercial points and Quality Plan etc., to speed up the process before opening the price bids
6. Inspection shall be done by BHEL/BHEL Authorised Agency and BHEL's Customer.

Commercial :

1. The prices quoted by the Bidder shall be on F.O.R. Ex-works basis with Freight extra for transportation of Finished pipes to Rayalseema Site. Price quoted shall be " FIRM " till the execution of the complete scope with raw material plate in their scope.
2. Payment for freight will be based on per meter. The Bidder shall clearly indicate whether Service Tax for Transportation is included or not in the Freight Rate quoted. Documentary evidence for proof of payment of Service Tax shall be submitted for payment.
3. The bidder shall confirm in this Part of bid that he has given all the breakups as requested in the price bid format as enclosed (Part II - Price) .
(The bidder shall also enclose in Part I a copy of un priced - Price part format to know whether the bidder have taken care of all the points).
4. The bidder shall clearly indicate the applicable Taxes / Duties / CESS. (See Format).
5. Delivery - 31st March 2008.
6. LD @ 0.5 % per week subject to a maximum of 15% for the undelivered portion shall be levied.
7. Bidder shall give a minimum validity of 60 days for the offer i.e 60 days from the date of opening of Price Bids.
8. Payment terms - 100 % against Acknowledged Lorry way Bill from Site and within 60 days from the date of submission of clear documents, as listed below,
 - a. Invoice (Original).
 - b. Excise Gate Pass if applicable.
 - c. Acknowledged Lorry Way Bill / Delivery Challan.
 - d. Original Test certificate and Inspection reports.

The Bidders shall strictly adhere to the Payment Terms as indicated above.

9. In case of incomplete / inadequate information provided against the requirements of this tender the offer shall be liable for rejection.

10. L1 bidder shall not automatically qualify for getting the order and BHEL has the right to negotiate price and delivery and if warranted BHEL shall also split the order on two or more parties. If split between 2 parties the ratio shall be 60:40. 60% on original L1 bidder and 40% to L2 bidder who has matched with L1 price.

PART - II - PRICE :

In this part of bid, the bidder shall provide the price strictly in the below mentioned format In this addition to the hard copy, the bidder has to submit in soft copy also in excel format. This format for which shall be sent and the same is to be submitted along with the offer (Refer Annexure - Price Format).

- a. Base Price shall include Cost of Raw Material plus conversion cost per Mtr of bare pipe including Edge Preparation and providing Spider Arrangement and Testing as per TDC : TDG : 07 : 05.
- b. Ordering shall be on FOR - Site basis .
- c. Percentage of applicable Taxes, Duties and CESS shall be clearly indicated .
- d. Service Tax on transportation if included shall be clearly indicated.
- e. A soft copy of the price format with price details are also to be sent along with price bid.
(Preferably in CD).

The Price quoted shall be " FIRM " till complete execution of the scope and bidder shall give **validity** of this price offer for a period of **minimum 60 days** from the date of opening of Price Bids.

LIST OF DOCUMENTS ENCLOSED :

1. TDC : TDG: 07:05.
2. QP No. 6928 : QPC : 01 Rev 00 Dt. 05.12.07
3. Edge Preparation Drawing No. No. 4-80-468-58799 Rev 00
4. Spider Arrangement Drawings 3-80-468-21868, 3-80-468-21987.

The above documents from part of this tender document and bidder shall ensure that they have received all these along with tender and confirm.

- **Pre Qualified** is the criteria for consideration for other than the BHEL Approved Vendors. After qualifying for registration, the new Vendors, may be considered for future inline with their system and policy. Such Vendors will not be considered in this Enquiry.
- The new Vendors may download Vendor registration forms from BHEL Web Site www.bhel.com and submit all relevant data for formal registration.

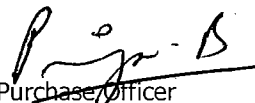
Sr. Purchase Officer

: 4 :

PRICE :

In this part of bid, the bidder shall provide the price strictly in the below mentioned format.

a. Under Ground - As per Sl.no. 2.1 (a and b) and 3.2 of Painting Scheme

Sl. No	Pipe Size	Total Qty in Mtrs	Base Price of Pipe	Extra Coating Rate/Mtr (Coal Tar Primer - 1 x 30 Microns) - Primer Coat	Extra inside Coating Rate/Mtr (Coal Tar Epoxy - 2 x 60 Microns) - Over Coat	Extra Coating Rate/Mtr (Red Oxide Zinc Chromate Primer IS 2074 - 1 x 25 Microns)	Extra Transportation Cost/Mtr of Finished Pipe to Rayalseema Site
			(Ex-Works) as per TDC: TDG:07:05				
USE EXCEL FILE -PRICE FORMAT- GIVEN BY US (REFER ENCLOSED PRICE FORMAT) FOR GIVING YOUR OFFER							

b. Over Ground - As per Sl.no. 2.1 (a and b) and 3.1 of Painting Scheme

Sl. No	Pipe Size	Total Qty in Mtrs	Base Price of Pipe	Extra Coating Rate/Mtr (Coal Tar Primer - 1 x 30 Microns) - Primer Coat	Extra inside Coating Rate/Mtr (Coal Tar Epoxy - 2 x 60 Microns) - Over Coat	Extra Outside Coating Rate/Mtr (Red Oxide Zinc Chromate-Alkyd Base to IS 2074 - 2 x 25 Microns) - Primer	Extra Coating Rate/Mtr (Synthetic Enamel IS 2932 Smoke Shade No. 692 per IS 5 - 2 x 50 Microns) - Finish Paint	Extra Transportation Cost/Mtr of Finished Pipe to Rayalseema Site
			(Ex-Works) as per TDC: TDG:07:05					
USE EXCEL FILE -PRICE FORMAT- GIVEN BY US (REFER ENCLOSED PRICE FORMAT) FOR GIVING YOUR OFFER								

PROJECT: RAYALASEEMA- TPS - Stage III 1 X 210MW Unit - 5

SYSTEM: CW PIPING
CUSTOMER NO : 0393 , 6928

MANUFACTURING QUALITY PLAN

ITEM : CW PIPING
Straight Pipes
QP No: 6928 : QPC: 04
REV: 00
DATE : 05.12.2007
PAGE : 1 OF 2

CONTRACTOR'S NAME & ADDRESS
BHEL PIPING CENTRE - CHENNAI - 600 017
QUALITY ASSURANCE & CONTROL DEPT.
QA 03

SL No	COMPONENT & OPERATION	CHARACTERISTICS	CLASS	TYPE OF CHECK	QUANTUM OF CHECK	REFERENCE DOCUMENT	ACCEPTANCE NORMS	FORMAT OF RECORD			AGENCY			REMARKS
								M	B	C	M	B	C	
1	STRAIGHT PIPE: IS3589 (Longitudinal /spiral welded pipes)	Chemical Mechanical Soundness Dimension	Major Major Major	Verification Tensile test Hydraulic test or Radiography Measurement	As per Mail spec 100%	IS 3589 IS 3589 IS 3589	IS 3589	TC TC TC	P P P	V W W	R R W*	10% witness by BHEL		
2.0	Surface preparation of pipes	Degree of cleanliness	Major	Visual	100%	SA 2 1/2		HC	P	W*	R	TC: Test certificate HC: History card *Random Witness Paint Brands Berger Shalimar Asian Jenson & Nicholson		
2.1	Coating (internal surfaces) for pipes OD 1000mm and above													
(a)	PRIMER	Coal tar Primer	Major	visual measurement	Each pipe		Minimum DFT: 30 microns	HC	P	V	R			
(b)	OVER COAT	Coal tar epoxy	Major	Visual & measurement	Each pipe		2 coats. DFT: 60 microns min Per coat. Total DFT: Primer + Over coat = 150 microns min.	HC	P	W	R			
(c)	Inspection of Coating	Dry film thickness (DFT) Holiday detection	Major Major	Visual & Elcometer Measurement Visual	Each pipe 100%		DFT 150 microns min. No Holiday	HC	P	W	W*			

** M: MANUFACTURER / SUBCONTRACTOR. B: BHEL
C: Customer (APGENCO)
INDICATE "P" PERFORM, "W" WITNESS, AND "V" VERIFICATION
AS APPROPRIATE.
R: Record Review W*: Witness (Random)

PREPARED BY
P. ANARTHANAN.
REVIEWED & APPROVED BY
P. ELANGOYAN.
NAME & SIGNATURE

Mr S
18/12
CHIEF ENGINEER,
Central Projects Const.
APGENCO Vidvut Soudha,
Hyderabad - 500 082.

CONTRACTOR'S NAME & ADDRESS BHEL PIPING CENTRE - CHENNAI - 600 017 QUALITY ASSURANCE & CONTROL DEPT. QA 03		MANUFACTURING QUALITY PLAN						PROJECT: RAYALASEEMA - TPS - Stage III X 210MW Unit - 5 SYSTEM: CW PIPING CUSTOMER NO : 0393 , 6928					
		ITEM : CW PIPING Straight Pipes	Qp No: 6928 : QPC: 04 REV: 00 DATE : 05.12.2007 PAGE : 2 OF 2	SL No	COMPONENT & OPERATION	CHARACTERISTICS	CLASS	TYPE OF CHECK	QUANTUM OF CHECK	REFERENCE DOCUMENT	ACCEPTANCE NORMS	FORMAT OF RECORD	AGENCY
1	2	3	4	5	6	7	8	9	10	11	M	B	C
3.0	Coating (External surfaces) Over ground piping, Surface preparation of out side surface	Power tool cleaning/ Major	Major	Visual	100%	Free from all dirt, oil, grease, rust, scale, weldslag, fluxdeposit, foreign matters etc	HC	P	V	R			
3.1	Primer	Red Oxide Zinc Chromate (Alkyd base to IS 2074)	Major	Visual & Measurement	100%	2 coats, DFT 25 microns minimum per coat.	HC	P	V	W*			
	Finish paint	Synthetic enamel IS2932 smoke grey shade No.692 As per IS: 5	Major	Visual & Measurement	100%	2 Coats, DFT 50 microns minimum per coat. Total DFT: Primer + Finish = 150 microns minimum.	HC	P	W	W*			
3.2	Coating (External Surfaces) Pipes buried (under ground), Temporary protection - (as Coal Tar Tape wrapping shall be carried out at site by Erection Agency.) Surface preparation of out side surface Primer	Power tool cleaning Major	Major	Visual	100%	Free from all dirt, oil, grease, rust, scale, weldslag, fluxdeposit, foreign matters etc	HC	P	V	R			
		Red oxide zinc chromate Primer IS 2074	Major	Visual & Measurement	100%	Minimum DFT: 25 microns	HC	P	W	W*			
4.0	Marking & Identification	Work order NO, Du No, Length, Makers Identification	Major	Visual	100%	Each pipe punched & stenciled As per P.O	HC	P	W				
													 18/12 CHIEF ENGINEER, Thermal Projects Const. AP GENCO, Viduth Soudha, Hyderabad - 500 082.

CAUTION: The information on this document is the property of BHARAT HEAVY ELECTRICALS LTD. It must not be used directly or indirectly in any way detrimental to the interest of the company.

REV	DATE	ALTERED
		APPROVED

ALL DIMENSIONS ARE IN MILLIMETRES

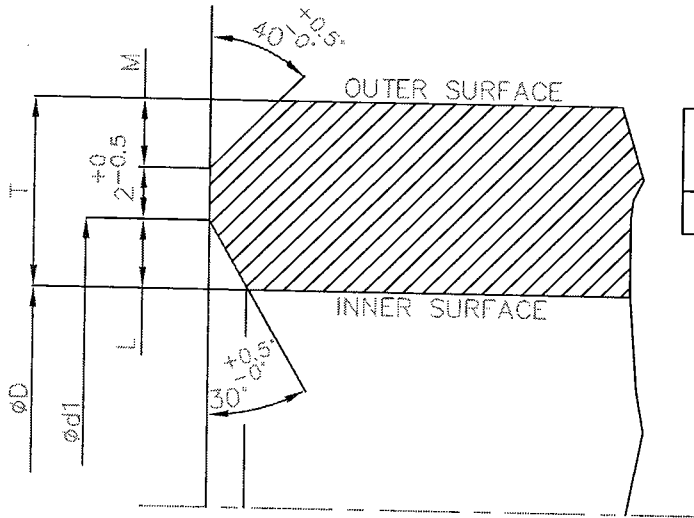

PIPE SIZE OD X T	$\phi d1$	ϕD	T	L	M
ϕ 2540 X 20	2526	2500	20	13	5

FIG-A

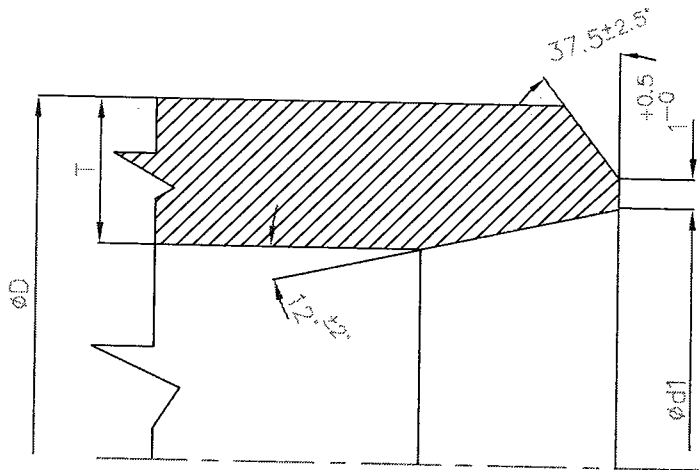

PIPE SIZE ϕD X T	$\phi d1$
ϕ 1626 X 16	1594.0
ϕ 1626 X 14	1598.0

STYLE-D

RAYALASEEMA LP PIPING 2x210 MW



BHARAT HEAVY ELECTRICALS LIMITED
PIPING CENTRE
CHENNAI 600 017

DRN	NAME	SIGN	DATE	NO. OF VAR
CHD	A.G.JASMIN		13.09.04	
APPD	T.N.LANGOYAN		13.09.04	
	R.C.SEKHAR		13.09.04	

DEPT	GRADE OF UNTOL. DIM	SCALE	WEIGHT (KG).	REF. TO ASSY./OLD DRG.	ITEM NO.	NO. OF ITEMS
CODE	C / M / F	N.T.S				
TITLE				CARD CODE	DRAWING NO.	
EDGE PREPARATION DETAIL				U 01	4-80-468-58799	
					REV	
					00	

7861Z-897-08-3

DRAWING No

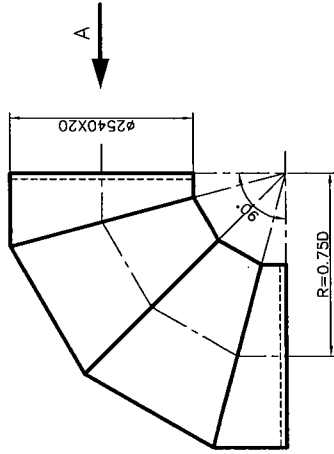
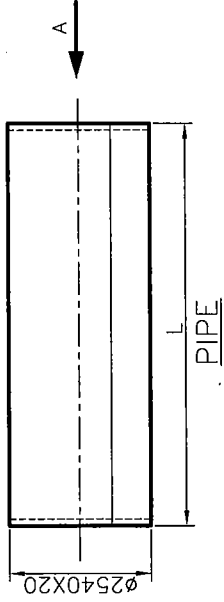

90° MITRE BEND

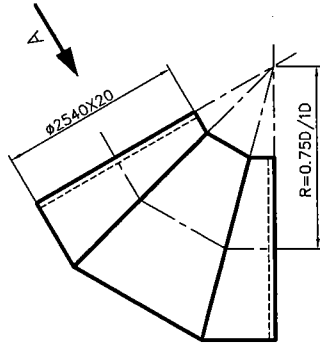

60°/45° MITRE BEND

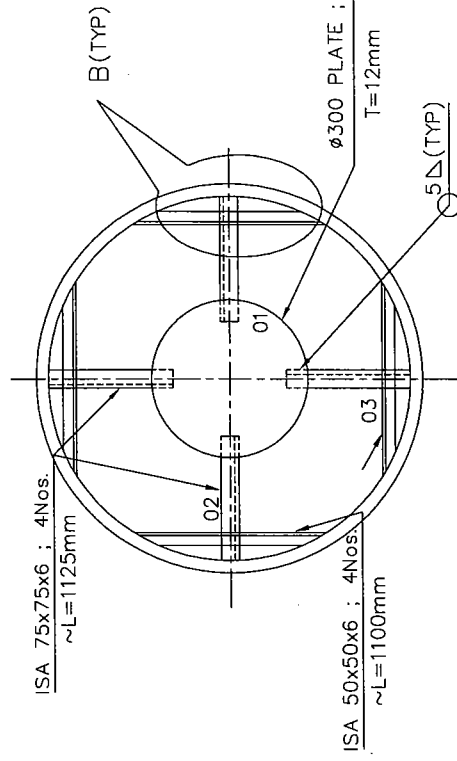

VIEW - A

NOTES

1. QUANTITY INDICATED IN BOM IS FOR ONE MITRE BEND/PIPE.
2. MATERIAL FOR SPIDER ARRANGEMENT IS TEMPORARY MATERIAL WHICH WILL BE CUT AND REMOVED AT SITE.HENCE THIS MATERIAL IS NOT COVERED IN GMS AND HAS TO BE PROVIDED BY SUB CONTRACTOR.

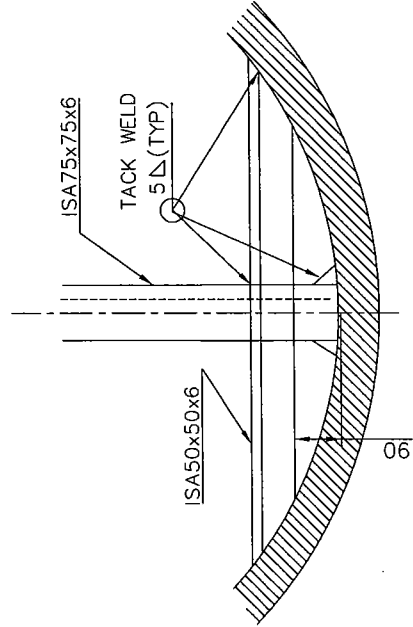

DETAIL - B

VAR NO.	ITEM NO.	DESCRIPTION	DRAWING NO.	ITEM NO. FOR BOM	MATERIAL CODE	MATERIAL SPEC.	UNIT WT.	QTY.
	03	ISA50x50x6 L=1100		15013056000	IS2062Fe410A	A	8	950
	02	ISA 75x75x6 L=1125		15013005000	IS2062Fe410A	A	8	650
	01	PLATE 300 T=12		15011132000	IS2062Fe410A	A	2	655

TYPE OF PRODUCT OR NAME OF CUSTOMER/PROJECT



BHARAT HEAVY ELECTRICALS LTD.,
PIPING CENTRE,
CHENNAI 600 017

NO OF ITEMS	DATE	SIGN	NAME	DRN
24.11.04	A.C.JASMIN			
24.11.04	T.N.ELANGOVAN			
24.11.04	APPPT.N.ELANGOVAN			

REV	DATE	ALTERED APPROVED	DEPT.	GRADE OF UN TOL DIM	SCALE	WEIGHT (kg)	REF TO ASSY / OLD DRG	ITEM No.
01				C/M/F		114.11		

TITLE	CARD CODE	DRAWING No.	REV
SPIDER ARRANGEMENT OD 2540	U 01	3-80-468-21987	

CAUTION THE INFORMATION ON THIS DOCUMENT IS THE PROPERTY OF BHARAT HEAVY ELECTRICALS LIMITED. IT MUST NOT BE USED DIRECTLY OR INDIRECTLY IN ANY WAY DETRIMENTAL TO THE INTEREST OF THE COMPANY

FIRST ANGLE PROJECTION(ALL DIMENSIONS IN MILLIMETRES)

3-80-468-21868
DRAWING No

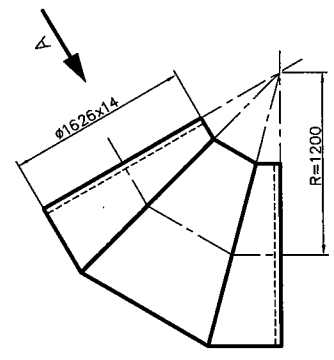
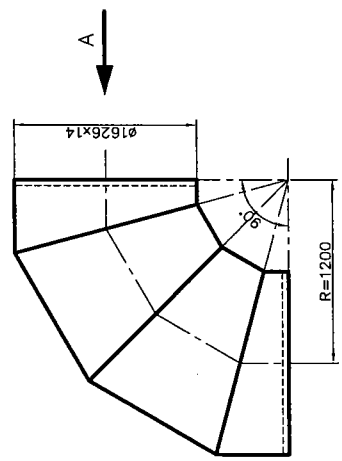
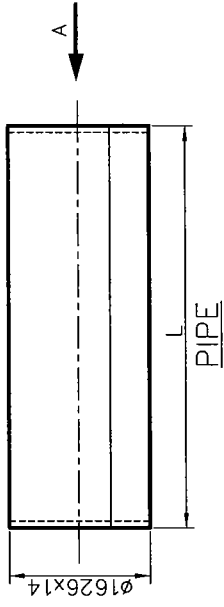

VIEW - A

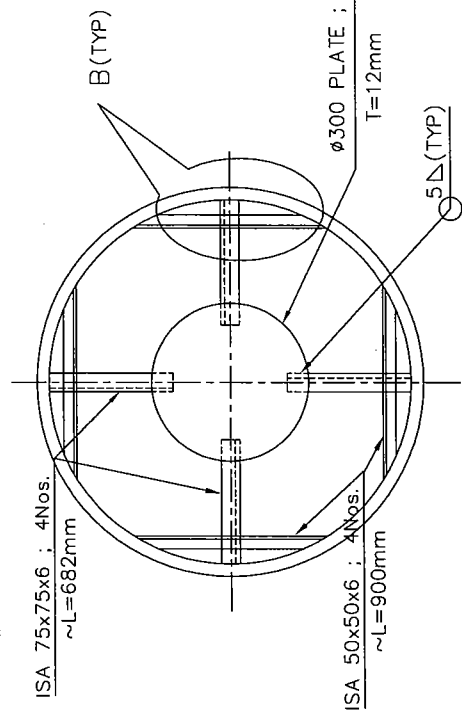

NOTES

1. QUANTITY INDICATED IN BOM IS FOR ONE MITRE BEND/PIPE.
2. MATERIAL FOR SPIDER ARRANGEMENT IS TEMPORARY MATERIAL WHICH WILL BE CUT AND REMOVED AT SITE.HENCE THIS MATERIAL IS NOT COVERED IN GMS AND HAS TO BE PROVIDED BY SUB CONTRACTOR.

90° MITRE BEND

60°/45° MITRE BEND

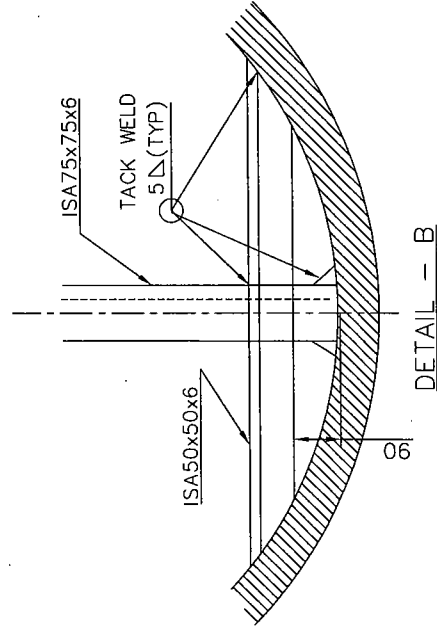

VAR NO.	ITEM NO.	DESCRIPTION	DRAWING NO.	ITEM NO. FOR MAT.	MATERIAL CODE	UNIT WT.	QTY.
	03	ISA50x50x6 L=900			15013056000	4	050
	02	ISA 75x75x6 L=682			IS2062Fe410A	8	650
	01	PLATE φ300 T=12			15011132000	6	650
					IS2062Fe410A	2	
					MATERIAL SPEC.	A	
					MATERIAL SPEC.	C	

TYPE OF PRODUCT OR NAME OF CUSTOMER/PROJECT

BHARAT HEAVY ELECTRICALS LTD., PIPING CENTRE, CHENNAI 600 017		DRN	NAME	SIGN	DATE	NO OF ITEMS
		CHD	A.G.JASMIN		28.09.04	28.09.04
DEPT.	GRADE OF UN TOL DIM	SCALE	WEIGHT (Kg)	REF TO ASSY / OLD DRG	ITEM No.	REV
C/M/F	C/M/F	82.900	82.900			
TITLE	CARD CODE	DRAWING No.				
SPIDER ARRANGEMENT NB 1600	U 01	3-80-468-21868				

CAUTION THE INFORMATION ON THIS DOCUMENT IS THE PROPERTY OF BHARAT HEAVY ELECTRICALS LIMITED. IT MUST NOT BE USED DIRECTLY OR INDIRECTLY IN ANY WAY DETRIMENTAL TO THE INTEREST OF THE COMPANY