

भारतीय मानक
ए सी स्थैतिक घंटा मीटर, वर्ग 1 और 2 — विशिष्टि
(पहला पुनरीक्षण)

Indian Standard
ac STATIC WATTHOUR METERS,
CLASS 1 AND 2 — SPECIFICATION
(*First Revision*)

ICS 91.140.50

© BIS 1999
BUREAU OF INDIAN STANDARDS
MANAK BHAVAN, 9 BAHADUR SHAH ZAFAR MARG
NEW DELHI 110002

FOREWORD

This Indian Standard (First Revision) was adopted by the Bureau of Indian Standards, after the draft finalized by the Equipment for Electrical Measurement and Load Control Sectional Committee had been approved by the Electrotechnical Division Council.

This Indian Standard covers the general requirements and tests for various types of ac static watthour meters of class 1 and 2 generally in line with the requirements for induction meters. However, the general requirements and tests applicable to transformer operated static watthour meters of class 0.2S and 0.5S with performance levels attainable in such meters have been covered in a separate Indian Standard.

This standard was first published in 1993. This revision has been brought out to update some requirements and to have parity between two standards.

The test levels as specified in this standard are regarded as minimum values to guarantee the proper function of the meter under normal working conditions. For special applications other test levels might be necessary and have to be fixed between the user and the manufacturer.

For tests and test criteria existing tests and test levels have been taken from IS 13010 : 1993 'ac watthour meters class 0.5, 1 and 2 — Specification'. New tests have been added in respect of electromagnetic compatibility (EMC) and electromagnetic interference (EMI) for which relevant part and section of IEC 61000 series may be referred.

The following publications have also been referred to in this standard:

- a) IEC 60068-2-75 (1997) Environmental testing — Part 2-75 : Tests — Test Eh: Hammer tests
- b) ISO 75-1: 1993 Determination of temperature of deflection under load — Part 1: General test method
- c) ISO 75-2: 1993 Determination of temperature of deflection under load — Part 2: Plastics and ebonite

The reliability aspect is not covered in this standard as there are no short time test procedures available which would fit in the type test to substantially check this requirement. Also influence of various harmonics and suitable test procedures to determine such influence, require detailed consideration for specifying such requirement.

While preparing this standard assistance has been mainly derived from the following publications:

IEC 61036 (1996) 'Alternating current static watthour meters for active energy (classes 1 and 2)' issued by the International Electrotechnical Commission.

Technical Report No. 88 'Specification for ac static electrical energy meters' issued by Central Board of Irrigation and Power, New Delhi. First Revision 1996 in respect of some recommendations irrespective of accuracy class.

Regarding test output the recommendation of CBIP Technical Report No. 88 first revision, 1996 has been adopted in this standard in view of various approved devices prevailing in the country.

For the purpose of deciding whether a particular requirement of this standard is complied with, the final value, observed or calculated, expressing the result of a test, shall be rounded off in accordance with IS 2 : 1960 'Rules for rounding off numerical values (*revised*)'. The number of significant places retained in the rounded off value should be the same as that of the specified value in this standard.

Indian Standard
**ac STATIC WATTHOUR METERS,
 CLASS 1 AND 2 — SPECIFICATION**
(First Revision)

1 SCOPE

1.1 This standard specifies static watthour meters of accuracy class 1 and 2, for the measurement of alternating-current electrical active energy of frequency in the range 45 Hz to 55 Hz for single-phase and three-phase balanced and unbalanced loads. It applies to their type tests, routine tests and acceptance tests.

1.2 It applies only to static watthour meters consisting of measuring element(s) and register(s) enclosed together in the meter case. It also applies to operation indicator(s) and test output(s). It also applies to multirate tariff meters and meters which measure energy in both directions.

1.3 It does not apply to :

- a) Watthour meters, where the voltage across the connection terminal exceeds 600 V (line to line voltage for meters for polyphase systems);
- b) Portable meters and outdoor meters;
- c) Elements enclosed in the meter case such as impulse device, time-switches, remote control elements, maximum demand indicator etc, and
- d) Data interfaces to the register of the meters.

1.4 For rack-mounted meters, the mechanical properties are not covered in this standard.

2 REFERENCES

The Indian Standards listed in Annex A are necessary adjuncts to this standard.

3 TERMINOLOGY

3.0 For the purpose of this standard, the following definitions shall apply.

3.1 General**3.1.1 Watthour Meter (Active Energy Meter)**

An instrument which measures and registers active energy in watthours or in suitable multiples thereof, by integrating active power with respect to time.

3.1.2 Static Watthour Meter

A watthour meter in which current and voltage act on solid state (electronic) elements to produce an output proportional to watthours.

3.1.3 Multi-Rate Meter

A watthour meter provided with a number of registers, each operative at specified time intervals corresponding to different tariffs.

3.1.4 Meter Type

Designation used for defining a particular design of meter manufactured by one manufacturer, having

- a) similar metrological properties;
- b) the same principle of operation and uniform construction of parts determining these properties; and
- c) the same ratio of the rated maximum current to the basic current.

The type may have several values of basic current and several values of reference voltage.

These meters are designated by the manufacturer by one or more groups of letters or numbers or of a combination of letters and numbers. Each type has one designation only.

NOTE — The type is represented by the sample meter(s) intended for the type tests and whose characteristics (basic current and reference voltage) are chosen from the values proposed by the manufacturer.

3.2 Terms Related to Functional Elements**3.2.1 Measuring Element**

Part of the meter which produces an output proportional to the energy.

3.2.2 Output Devices**3.2.2.1 Test output**

A device at which output from the measuring element is available for testing of the meter. The output may be in the form of pulses or high resolution register.

3.2.2.2 Operation indicator

A device which gives a visible signal of the operation of the meter. The test output may also act as operation indicator.

3.2.3 Memory

An element which stores digital information in a struc-

tured manner for subsequent retrieval whenever addressed.

3.2.4 Non-Volatile Memory (NVM)

A memory which can retain stored information in the absence of power.

NOTE—Memory chip with internal battery needing no replacement during the life time of meter may be considered as non-volatile memory, but memory with external battery shall not be considered as NVM.

3.2.5 Display

A device which visibly displays the contents of memory(ies).

3.2.6 Register

An electromechanical or electronic device comprising both memory and display which stores and displays information. A single display may be used with multiple electronic memories to form multiple registers.

3.2.7 Current Circuit

The internal connections of the meter and part of the measuring element through which flows the current of the circuit to which the meter is connected.

3.2.8 Voltage Circuit

The internal connections of the meter, part of the measuring element and power supply to the meter, supplied from the voltage of the circuit to which the meter is connected.

3.2.9 Auxiliary Circuit

The elements (lamps, contacts, etc) and connections of an auxiliary device within the meter case intended to be connected to an external device, for example, clock, relay, impulse counter.

3.2.10 Meter Constant

Constant expressing the relation between the energy registered by the meter and the corresponding pulse count of the test output. This is generally expressed either as pulse count per watthour or pulse count per kilo watthour (imp/kWh) or watthour per pulse (Wh/imp). This definition is not applicable for meters having high resolution registers.

3.3 Terms Related to Mechanical Elements

3.3.1 Indoor Meter

A meter which can only be used in areas which have additional protection against environmental influences (inhouse, enclosures and cabinets).

3.3.2 Outdoor Meter

A meter which can be used without additional protec-

tion in an exposed outdoor environment.

3.3.3 Meter Base

The back of the meter by which it is generally fixed and to which are attached the measuring element, the terminals or the terminal block, and the cover. For a flush-mounted meter, the meter base may include the sides of the case.

3.3.4 Meter Cover

The enclosure on the front of the meter, made either wholly of transparent material or opaque material provided with window(s) through which the operation indicator (if fitted) and the display can be read.

3.3.5 Meter Case

This comprises the base and the cover.

3.3.6 Accessible Conducting Part

A conducting part which can be touched by the standard test finger, when the meter is installed ready for use (see IS 1401).

3.3.7 Protective Earth Terminal

The terminal connected to accessible conducting parts of a meter, for safety purposes.

3.3.8 Terminal Block

A support made of insulating material on which all or some of the terminals of the meter are grouped together.

3.3.9 Terminal Cover

A cover which covers the meter terminals and generally the ends of the external wires or cables connected to the terminals.

3.3.10 Clearance

The shortest distance measured in air between two conductive parts.

3.3.11 Creepage Distance

The shortest distance measured over the surface of insulation between two conductive parts.

3.4 Terms Related to Insulations

3.4.1 Basic Insulation

The insulation applied to live parts to provide basic protection against electric shock.

NOTE—Basic insulation does not necessarily include insulation used exclusively for functional purposes.

3.4.2 Supplementary Insulation

An independent insulation applied in addition to the

basic insulation, in order to provide protection against electric shock in the event of a failure of the basic insulation.

3.4.3 Double Insulation

An insulation comprising both, basic insulation and supplementary insulation.

3.4.4 Reinforced Insulation

A single insulation system applied to live parts, which provides a degree of protection against electric shock equivalent to double insulation.

NOTE — The term 'insulation system' does not imply that the insulation must be one homogenous piece. It may comprise several layers which can not be tested singly as supplementary or basic insulation.

3.4.5 Insulating Encased Meter

A meter with case of insulating material in which protection against electric shock does not rely on basic insulation only, but in which additional safety precautions, such as double insulation or reinforced insulation, are provided. There being no provision for protective earthing or reliance upon installation conditions.

3.5 Terms Related to Meter Quantities

3.5.1 Basic Current (I_b)

The value of current in accordance with which the relevant performance of the meter is fixed.

3.5.2 Rated Maximum Current (I_{Max})

The highest value of current at which the meter purports to meet the accuracy requirements of this standard, when this current flows continuously in the meter.

3.5.3 Reference Voltage

The value of voltage in accordance with which the relevant performance of the meter is fixed.

3.5.4 Reference Frequency

The value of frequency in accordance with which the relevant performance of the meter is fixed.

3.5.5 Class Index

A number which gives the limits of the permissible percentage error, for all values of current between $0.1 I_b$ and I_{Max} for unity power factor (and in the case of polyphase meters with balanced loads) when the meter is tested under reference conditions (including permitted tolerances on the reference values) as defined in this standard.

3.5.6 Percentage Error

The percentage error is given by the following formula :

$$\text{Percentage error} = \frac{\text{Energy registered by the meter} - \text{True energy}}{\text{True energy}} \times 100$$

NOTE — Since the true value cannot be determined, it is approximated by a value with a stated uncertainty that can be traced to IS 12346 or standards agreed upon between manufacturer and user.

3.5.7 Repeatability of Error

Repeatability of error is the degree of closeness of agreement between results of successive error for tests carried out under identical conditions, arising out of factors other than measurement uncertainties.

It is generally measured by standard deviation of sufficiently large number of test data. It may also be measured by dispersion of such data under limited condition when sufficiently large data is not available.

3.6 Terms Related to Influence Quantities

3.6.1 Influence Quantity or Influence Factor

Any quantity, generally external to the meter, which may affect its working performance.

3.6.2 Reference Conditions

The appropriate set of influence quantities and performance characteristics, with reference values, their tolerances and reference ranges, with respect to which the intrinsic error is specified.

3.6.3 Variation of Error Due to an Influence Quantity

The difference between the percentage error of the meter when only one influence quantity assumes successively two specified values, one of them being the reference value.

3.6.4 Distortion Factor

The ratio of the r.m.s. value of the harmonic content (obtained by subtracting from a non-sinusoidal alternating quantity, its fundamental component) to the r.m.s. value of the non-sinusoidal quantity. The Distortion Factor is usually expressed in percentage.

3.6.5 Electromagnetic Disturbance

Conducted or radiated electromagnetic effects which may interfere functionally or metrologically with the operation of the meter.

3.6.6 Reference Temperature

The ambient temperature specified for reference conditions.

3.6.6.1 Mean temperature coefficient

The ratio of the variation of the percentage error to the change of the temperature which produces this variation.

3.6.7 Operating Conditions

A set of specified measuring ranges for performance characteristics and specified operating ranges for influence quantities, within which the variations in percentage errors of a meter are specified and determined.

3.6.8 Specified Measuring Range

The set of values of a measured quantity for which the percentage errors of a meter is intended to lie within specified limits.

3.6.9 Specified Operating Range

A range of values of a single influence quantity which forms a part of the operating conditions.

3.6.10 Limit Range of Operation (Limiting Conditions)

The extreme conditions which an operating meter can withstand without damage and without degradation of its metrological characteristics when it is subsequently operated under its operating conditions.

3.6.11 Storage and Transport Conditions

The extreme conditions which a non-operating meter can withstand without damage and without degradation of its metrological characteristics when it is subsequently operated under its operating conditions.

3.6.12 Normal Working Position

The position of the meter defined by the manufacturer for normal service.

3.6.13 Thermal Stability

Thermal stability is considered to be reached when the change in error as consequence of thermal effects during 20 minutes is less than 0.1 times the maximum permissible error for the measurement under consideration.

3.7 Terms Related to Tests

3.7.1 Type Tests

Series of tests carried out on one meter or a small number of meters of the same type having identical characteristics, selected by manufacturer to prove conformity with all the requirements of this standard for the relevant class of meter. These are intended to prove the general qualities and design of a given type of meter.

3.7.2 Routine Tests

Tests carried out on each meter to check conformity

with the requirements of this standard in aspects which are likely to vary during production.

3.7.3 Acceptance Test

Tests carried out on samples taken from a lot for the purpose of acceptance of the lot.

NOTE — However specific qualities and design of the meters in a lot can be conclusively proved by performing relevant type test(s) on a number of samples if agreed by the user and the supplier.

4 CLASSIFICATION

4.1 Meters are classified according to their respective class indices, for example, 1 or 2.

5 RATINGS

5.1 Standard Reference Voltages

The reference voltage shall be one of the values given in Table 1 (see IS 12360).

Table 1 Standard Reference Voltages

Meters for (1)	Standard Reference Voltage (V) (2)	Exceptional Values (V) (3)
Connection through voltage transformer	57.7 (100), 63.5 (110)	100 (173)
Direct connection and through current transformer only	230 (400), 240 (415)	220 (380), 250 (433)

5.2 Standard Basic Currents

The basic currents shall be as given in Table 2.

Table 2 Standard Basic Currents

Meters for (1)	Basic Currents (A) (2)
For direct connection	
1-phase	2.5, 5, 10, 15, 20
3-phase	5, 10, 15, 20, 30, 40, 50
Connection through current transformer(s)	1, 5

5.3 Rated Maximum Current

The rated maximum currents shall be as given in Table 3.

5.4 Standard Frequency

Standard value for reference frequency is 50 Hz.

6 GENERAL AND CONSTRUCTIONAL REQUIREMENTS

6.1 General

Meters shall be designed and constructed in such a way as to avoid introducing any danger in normal use and under normal conditions, so as to ensure especially:

- personal safety against electric shock.
- personal safety against effects of excessive temperature.
- safety against spread of fire.
- protection against solid objects, dust and water.

Table 3 Rated Maximum Current
(Clause 5.3)

Meters for (1)	Rated Maximum Currents as Percentage of Basic Current (2)
For direct connection	
1-phase	200
3-phase	120
Connection through current transformer(s)	
1-phase	120
3-phase	120

NOTE — For long range applications rated maximum currents are usually higher multiples of basic currents. For example, 400 percent I_b for 1-phase direct connected meters, 200 percent I_b for 3-phase direct connected or CT operated meters and for 1-phase CT operated meters.

All parts which are subject to corrosion under normal conditions shall be effectively protected. Any protective coating shall not be liable to damage by ordinary handling nor damage due to exposure to air, used under normal working conditions.

NOTE — For meters for special use in corrosive atmosphere, additional requirements shall be fixed in the purchase contract (for example, salt mist test).

6.2 Meter Case

The meters shall have a case which can be sealed in such a way that the internal parts of the meter are accessible only after breaking the seal(s).

The cover shall not be removable without the use of a tool.

The case shall be so constructed and arranged that any non-permanent deformation cannot prevent the satisfactory operation of the meter.

Unless otherwise specified, the meters having a case wholly or partially made of metal, shall be provided with a protective earth terminal.

6.3 Window

If the cover is not transparent one or more windows shall be provided for reading the displays and observation of the operation indicator, if fitted. These windows shall be covered by toughened transparent material which cannot be removed/undamaged without breaking the seal(s).

6.4 Terminals, Terminals Block(s) and Protective Earth Terminal

Terminal may be grouped in a terminal block(s)

having adequate insulating properties and mechanical strength. In order to satisfy such requirements, when choosing insulating materials for the terminal block(s), adequate testing of materials should be taken into account.

The terminal block, the terminal cover (if not of metal) and the case (if not of metal) shall be of a material which complies with the requirements of IS 11731 (Part 1) method FH 1. The holes in the insulation material which form an extension of the terminal holes shall be sufficient size to accommodate also the insulation of the conductors.

The material of which the terminal block is made shall be capable of passing the tests given in ISO 75-1 : 1993 and ISO 75-2 : 1993 for a temperature of 135°C and a pressure of 1.8 MPa (Method A).

The manner of fixing the conductors to the terminals shall ensure adequate and durable contact such that there is no risk of loosening or undue heating. Screw connections transmitting contact force and screw fixings which may be loosened and tightened several times during the life of the meter shall screw into a metal nut.

The current circuit conductors of a meter shall be connected to its current terminals inside the meter terminal block adopting any of the recommended methods given in Annex B so as to ensure satisfactory durable and adequate contact surfaces between the conductors and the terminals.

All parts of every terminal shall be such that the risk of corrosion resulting from contact with any other metal part is minimized.

Electrical connections shall be so designed that contact pressure is not transmitted through insulating material of the terminal block.

For current circuits, the voltage is considered to be the same as for the related voltage circuit.

Terminals with different potentials which are grouped close together shall be protected against accidental short circuiting. Protection may be obtained by insulating barriers. Terminals of one current circuit are considered to be at the same potential.

The terminals, the conductor fixing screws, or the external or internal conductors shall not be liable to come into contact with terminal covers (if made of metals).

The protective earth terminal, if any:

- a) shall be electrically bonded to the accessible metal parts,
- b) should, if possible, form part of the meter base,

- c) should preferably be located adjacent to its terminal block,
- d) shall accommodate a conductor having a cross-section at least equivalent to the main current conductors but with a lower limit of 6 mm² and an upper limit of 16 mm², and
- e) shall be clearly identified by earthing symbol.

After installation, it shall not be possible to loosen the protective earth terminal without the use of a tool.

6.5 Terminal Cover(s)

Every terminal block shall be provided with a terminal cover conforming to 6.5.1 or 6.5.2.

6.5.1 Short Terminal Cover

The terminals, their fixing screws, and the insulated compartment housing them shall be enclosed by a cover with a provision for sealing. The cover may be of the same size as that of the terminal block. The wiring with this type of cover may be carried out from the front of the meter board.

6.5.2 Extended Terminal Cover

The terminals, their fixing screws, a suitable length of external insulated conductor and its insulation shall be enclosed by a cover with a provision for sealing. The wiring with this type of cover shall be carried out from the rear of the meter board.

The fixing screws used on the terminal cover for fixing and sealing in 6.5.1 and 6.5.2 shall be held captive in the terminal cover.

When the meter is mounted on the meter board, no access to the terminals shall be possible without breaking seal(s) of the terminal cover.

6.6 Clearances and Creepage Distances

The clearances and creepage distances of the terminal block and those between the terminals and the surrounding parts of the metal enclosure shall be not less than the value specified in Table 4.

The clearance between the terminal cover, if made of metal, and the upper surface of the screws when screwed down to the maximum applicable conductor fitted shall be not less than the relevant values indicated in Table 4.

The requirements of the impulse voltage test shall also be met (see 12.7.6.2).

6.7 Insulating Encased Meter

A meter having a durable and substantially continuous enclosure made wholly of insulating material,

Table 4 - Clearances and Creepage Distances
(Clause 6.6)

Voltage Phase-to-Earth Derived from Rated System Voltages (V) (1)	Minimum Clearances (mm) (2)	Minimum Creepage Distance (mm) (3)
Not exceeding 50	0.8	1.2
Not exceeding 100	0.8	1.4
Not exceeding 150	1.5	1.6
Not exceeding 300	3.0	3.2
Not exceeding 600	5.5	6.3

including the terminal cover, which envelops all metal parts with the exception of small parts, for example, name-plate screws, suspensions and rivets. If such small parts are accessible by the standard test finger (see IS 1401) from outside the case, then they shall be additionally isolated from live parts by supplementary insulation against failure of basic insulation or loosening of live parts. The insulating properties of lacquer, enamel, ordinary paper, cotton, oxide film on metal parts, adhesive film and sealing compound, or similar unsure materials, shall not be regarded as sufficient for supplementary insulation.

For the terminal block and the terminal cover of such a meter, reinforced insulation is sufficient.

6.8 Resistance to Heat and Fire

The terminal block, the terminal cover and the meter case shall ensure reasonable safety against spread of fire. They should not be ignited by thermic overload of live parts in contact with them. To comply therewith it must fulfil the tests as specified in 12.4.

6.9 Protection Against Penetration of Dust and Water

The meter shall conform to the degree of protection as given below :

IP 51, but without suction in the meter.

6.10 Display of Measured Values

The information can be shown either with an electro-mechanical register or an electronic display. In case of an electronic display the corresponding non-volatile memory shall have a minimum retention time of 5 years.

NOTE— Longer retention time of the non-volatile memory should be the subject of purchase contract.

In the case of multiple values presented by a single display it must be possible to display the contents of all relevant memories. When displaying the memory, identification of each tariff/parameter shall be available.

The current tariff shall be indicated. When the meter is not energised; the electronic display need not be visible.

The principal unit for the measured values shall be kilo watt-hour (kWh) or the mega watt-hour (MWh).

The register shall be able to record and display starting from zero, for a minimum of 1500 h, the energy corresponding to rated maximum current at reference voltage and unity power-factor. Register should not rollover in between this duration.

NOTE — Values higher than 1500 h should be the subject of purchase contract.

6.11 Output Device

The meter shall have a test output accessible from the front and be capable of being monitored with suitable testing equipment. The operation indicator, if fitted, must be visible from the front.

Since the sequence of test output pulses may not be homogeneous, the manufacturer shall state the minimum number of pulse counts necessary to ensure measurement accuracy at least 1/10th of the specified error limits at various points and consistent with desired resolution.

The resolution of the test output in the form of pulses or high resolution register, whether accessible on the meter through external display, shall be sufficient to conduct satisfactorily accuracy test at the lowest load in less than 5 minutes and starting current test in less than 10 minutes.

7 MARKING OF METERS

7.1 Name Plate

Every meter shall bear the following information if applicable :

- Manufacturer's name or trade-mark and if required, the place of manufacture.
- Designation of type (*see* 3.1.4) and, if required, space for approval mark.
- The number of phases and the number of wires for which the meter is suitable (for example, single-phase 2-wire, three-phase 3-wire, three-phase 4-wire). These markings may be replaced by the graphical symbols (as per IS 12032 series).
- The serial number and year of manufacture. If the serial number is marked on a plate fixed to the cover, the number is to be marked also on the meter base.
- The reference voltage in one of the following forms :

The number of elements if more than one, and the voltage at the meter terminals of the voltage circuit(s).

- The nominal voltage of the system or the secondary voltage of the instrument transformer to which the meter is intended to be connected.
 - Examples of voltage markings are shown in Table 5.
- Principal unit in which the meter reads, for example, kWh.
 - The rated secondary current of the transformer(s) to which the meter should be connected for example, thus: $-/5$ A: the basic current and the rated maximum current of the meter may be included in the type designation.

Examples of current markings are shown in Table 6.

Table 5 Voltage Markings

[Clause 7.1 (e)]

Type of Meter (1)	Method of Marking (2)	Example (3)
1-phase, 2-wire	Voltage between line and neutral	240 V
3-phase, 3-wire	$2 \times$ Voltage between lines	2×110 V
3-phase, 4-wire	$3 \times$ Voltage between line and neutral	$3 \times 110\sqrt{3}$ $\times 240$ V

Table 6 Current Markings

[Clause 7.1(g)]

Type of Meter (1)	Method of Marking (2)	Example (3)
1-phase, whole current, I_b 10 A, I_{Max} 20 A	Basic current and rated maximum current	10-20 A
1-phase, transformer operated, I_b 1 A, I_{Max} 1.2 A	Basic current	$-/1$ A
3-phase, whole current I_b 50 A, I_{Max} 60 A	Basic current	50 A
3-phase, transformer operated, I_b 5 A, I_{Max} 6 A	Basic current	$-/5$ A

- The reference frequency in Hz.
- The meter constant, for example, in the form: X Wh/imp or X imp/kWh.
- The class index of the meter.
- The reference temperature if different from 27°C.
- The sign of double square for insulating encased meters.

Information under (a), (b) and (c) may be marked on an external plate permanently attached to the meter cover.

The information under (d) to (k) shall be marked on a name plate preferably placed within the meter.

The marking shall be indelible, distinct and readable from outside the meter.

If the meter registers energy through instrument transformer(s), which are accounted in the meter constant, the transformation ratio(s) shall be marked.

Standard symbols may also be used (see IS 12032 series).

7.1.1 ac Static watt-hour meters can also be marked with BIS Standard Mark (if certified by BIS).

7.2 Connection Diagrams and Terminal Marking

Every meter shall be indelibly marked with a diagram of connections. For polyphase meters, this diagram shall also show the phase sequence for which the meter is intended. It is permissible to indicate the connection diagram by an identification figure in accordance with relevant standards.

If the meter terminals are marked, this marking shall appear on the diagram.

8 CLIMATIC CONDITIONS

8.1 Temperature Range

Temperature range of the meter shall be as indicated in Table 7.

Table 7 Temperature Range

Specified operation range	0°C to + 55°C
Limit range of operation	-10°C to + 60°C
Limit range for storage and transport	-10°C to + 70°C

NOTE— For special applications, other temperature values can be used according to agreement between manufacturer and purchaser.

8.2 Relative Humidity

The meter shall meet the relative humidity requirements of Table 8. For combined temperature and humidity test, see 12.6.3.

Table 8 Relative Humidity

Annual mean	< 75%
For 30 days, these days being spread in a natural manner over the year	< 95%
Occasionally on other days	< 85%

The limits of relative humidity as a function of ambient temperature are shown in Annex C.

The graph may be modified in line with metrological conditions prevalent in the place of use.

9 ELECTRICAL REQUIREMENTS

9.1 Power Consumption

9.1.1 Power Consumption in Voltage Circuit

The active and apparent power consumption in each voltage circuit of a meter at reference voltage reference temperature and reference frequency shall not exceed the values shown in Table 9.

Table 9 Power Consumption in Voltage Circuit Including the Power Supply

Meters	Class of Meters 1 and 2
Single phase and polyphase (per phase)	1.5 W and 8 VA

NOTES

1 The above figures are mean values. Switching power supplies with peak values in excess of these are permitted but attention should be paid to the rating of associated voltage transformers.

2 In case additional features like remote metering, prepayment metering etc are built into the meter then additional loss may be agreed between supplier and purchaser.

9.1.2 Power Consumption in Current Circuit

The apparent power taken by each current circuit at basic current, reference frequency and reference temperature shall not exceed the value shown in Table 10.

Table 10 Apparent Power Consumption in Current Circuit

Meters for	Class of Meters	
	1	2
Direct connection. Single-phase and polyphase (per phase)	4.0 VA	2.5 VA
Connection through current transformers. Single-phase and polyphase (per phase)	4.0 VA	2.5 VA

9.2 Influence of Supply Voltage

9.2.1 Voltage Range

Voltage range shall be as given in Table 11.

Table 11 Voltage Range

Specified operating range	0.80 to 1.1 Vref
Limit range of operation	0.70 to 1.2 Vref

NOTES

1 For the permissible error due to voltage variation (see Table 17).

2 Extended operating ranges will be the subject of purchase contract.

9.2.2 Voltage Dips and Interruptions

Voltage dips and interruptions shall not produce a change in the register of more than 0.01 kWh and the

test output shall not produce a signal equivalent to more than 0.01 kWh. These values are based on the rated current of 5A and 100 V of the meter. For other voltage and current ratings the value 0.01 kWh has to be converted accordingly. When the voltage is restored, the meter shall not have suffered degradation of its metrological characteristics.

Further, after this test the data from the memory should not be lost.

For testing, see 12.7.2.

9.2.3 Short-Time Over Current

Short-time over current shall not damage the meter. The meter shall perform correctly, when back to its initial working conditions and the variation of error shall not exceed the values shown in Table 12.

a) Meter for direct connection

The meter shall be able to carry a short time over current of $30 I_{Max}$ for one half-cycle at rated frequency.

b) Meter for connection through current transformer

The meter shall be able to carry for 0.5 s a current to 20 times the maximum current.

Table 12 Variations Due to Short-Time Over Currents
(Clause 9.2.3)

Meters for	Value of Current	Power Factor	Limits of Variation in Percentage Error for Meters of Class	
			1	2
Direct connection	I_b	1	1.5	1.5
Connection through current transformer	I_b	1	0.5	1.0

For testing, see 12.7.3.

9.3 Influence of Self-Heating

The variation in percentage error due to self-heating shall not exceed the values given in Table 13.

Table 13 Variation in Percentage Error Due to Self-Heating

Value of Current	Power Factor	Limits of Variation in Percentage Error for Meters of Class	
		1	2
I_{Max}	1	0.7	1.0
I_{Max}	0.5 lagging	1.0	1.5

For testing, see 12.7.4.

9.4 Influence of Heating

Under normal conditions of use, electrical circuits and insulation shall not reach a temperature which might adversely affect the operation of the meter. The temperature rise at any point of the external surface of the meter shall not exceed by more than 20 K with an ambient temperature at 45°C.

For testing, see 12.7.5.

9.5 Insulation

The meter and its incorporated auxiliary devices if any, shall be such that they retain adequate dielectric qualities under normal conditions of use, taking into account of the atmospheric influences and different voltages, to which they are subjected under normal conditions of use.

The meter shall withstand the impulse voltage test and the ac voltage test as specified in 12.7.6.

9.6 Immunity to Earth Fault

This test applies to three-phase four-wire meters.

During a test under a simulated earth fault condition in one of the three lines, all voltages are increased to 1.1 times the nominal voltages during 4 h. The neutral terminal of the meter under test is disconnected from the ground terminal of the meter test equipment (MTE) and is connected to the MTE's line at which the earth fault has to be simulated (see Annex F).

In this way the two voltage terminals of the meter under test which are not affected by the earth fault are connected to 1.9 times the nominal phase voltages. During this test the current circuits are set to 50 percent of the rated I_n power factor 1 and symmetrical load. After the test, the meter shall show no damage and shall operate correctly.

The change of error measured when the meter is back at nominal working temperature shall not exceed the limits give in Table 14.

For testing, see 12.8.

Table 14 Change of Error Due to Earth Fault

Value of Current	Power Factor	Limits of Variation in Percentage Error for Meters of Class	
		1	2
(1)	(2)	(3)	(4)
I_n	1	0.7	1.0

10 ELECTROMAGNETIC COMPATIBILITY (EMC)

10.1 Immunity to Electromagnetic Disturbance

The meter shall be designed in such a way that conducted or radiated electromagnetic disturbance as well as electrostatic discharge do not damage nor substantially influence meter.

- NOTE — The disturbances to be considered are
- Electrostatic discharge
 - Electromagnetic HF field
 - Fast transient burst

For testing, see 12.9.

10.2 Radio Interference Suppression

The meter shall not generate conducted or radiated noise which could interfere with other equipment.

For testing, see 12.9.5.

11 ACCURACY REQUIREMENTS

11.1 Limits of Error Due to Variation of the Current

When the meter is under the reference conditions given in 12.10.1 the percentage error shall not exceed the limits for the relevant accuracy class given in Tables 15 and 16.

If the meter is designed for the measurement of energy in both directions, the values in Tables 15 and 16 shall apply for each direction.

The difference between the percentage error when the meter is carrying a single-phase load at basic current and unity power factor and the percentage error when the meter is carrying balance polyphase load at basic current and unity power factor, shall not exceed 1.5 and 2.5 for meters of classes 1 and 2 respectively.

NOTE — When testing for compliance with Table 16 the test current shall be applied to each element, in sequence.

11.2 Limits of Error Due to Other Influence Quantities (Voltage-Variation, Frequency Variation, Phase-Sequence, Wave Form, Voltage-Unbalance)

Limits of variation in percentage error due to the change of influence quantities with respect to reference conditions, as given in 12.10.1, shall not exceed the limits for the relevant accuracy class given in Table 17.

11.3 Limits of Error Due to Ambient Temperature Variation

The mean temperature coefficient shall not exceed the limits given in Table 18.

Table 15 Percentage Error Limits (Single-Phase Meters and Polyphase Meters with Balanced Loads)

(Clause 11.1)

Value of Current		Power Factor	Percentage Error Limits for Meters of Class	
For direct connected meters (1)	For transformer operated meters (2)		1 (4)	2 (5)
$0.05 I_b \leq I_b \leq 0.1 I_b$	$0.02 I_b \leq I_b \leq 0.05 I_b$	1	± 1.5	± 2.5
$0.1 I_b \leq I_b \leq I_{Max}$	$0.05 I_b \leq I_b \leq I_{Max}$	1	± 1.0	± 2.0
$0.1 I_b \leq I_b < 0.2 I_b$	$0.05 I_b \leq I_b < 0.1 I_b$	0.5 lagging 0.8 leading	± 1.5 ± 1.5	± 2.5 —
$0.2 I_b \leq I_b \leq I_{Max}$	$0.1 I_b \leq I_b \leq I_{Max}$	0.5 lagging 0.8 leading	± 1.0 ± 1.0	± 2.0 —
When specially requested by the user: from $0.2 I_b$ to I_b	When specially requested by the user: from $0.1 I_b$ to I_b	0.25 lagging 0.5 leading	± 3.5 ± 2.5	— —

Table 16 Percentage Error Limits (Polyphase Meters Carrying a Single-Phase Load, but with Balanced Polyphase Voltages Applied to Voltage Circuits)

(Clause 11.1)

Value of Current		Power Factor of Relevant Element	Percentage Error Limits for Meters of Class	
For direct connected meters (1)	For transformer operated meters (2)		1 (4)	2 (5)
$0.1 I_b \leq I_b \leq I_{Max}$	$0.05 I_b \leq I_b \leq I_{Max}$	1	± 2.0	± 3.0
$0.2 I_b \leq I_b \leq I_{Max}$	$0.1 I_b \leq I_b \leq I_{Max}$	0.5 lagging	± 2.0	± 3.0

Table 17 Influence Quantities
(Clauses 9.2.1 and 11.2)

SI No.	Influence Quantities	Value of Current (Balanced Unless Otherwise Stated)	Power Factor	Limit of Variation in Percentage Error for Meters of Class	
				1	2
(1)	(2)	(3)	(4)	(5)	(6)
i)	Voltage variation ± 10 percent (see Note 1)	I_b	1 0.5 lagging	0.7 1.0	1.0 1.5
ii)	Frequency variation ± 5 percent	I_b	1 0.5 lagging	0.8 1.0	1.3 1.5
iii)	Wave form: 10 percent of third harmonic in the current (see Note 2)	I_b	1	0.6	0.8
iv)	Reversed phase sequence (see Note 3)	$0.1 I_b$	1	1.5	1.5
v)	Voltage unbalance (see Note 4)	I_b	1	2.0	4.0
vi)	dc component in ac current circuit (see Note 5)	$0.5 I_{Max}$	1	3.0	6.0
vii)	Continuous magnetic induction of external origin (see Note 6)	I_b	1	2.0	3.0
viii)	Magnetic induction of external origin 0.5 mT (see Note 7)	I_b	1	2.0	3.0
ix)	Electromagnetic HF fields (see Note 8)	I_b	1	0.5	1.0
x)	Operation of accessories (see Note 9)	$0.05 I_b$	1	0.5	1.0

NOTES

1 For the voltage ranges from -20 percent to -10 percent and $+10$ percent to $+20$ percent the limits of variation in percentage error are three times the values given in Table 17.

Below $0.8 V_{ref}$ and upto $0.7 V_{ref}$, the said limits are five times the value given in Table 17.

Below $0.7 V_{ref}$ the error of the meter may vary between $+10$ per cent and -100 percent.

2 The distortion factor of the voltage shall be less than 1 percent. The variation in percentage error shall be measured under two conditions. The peak of third harmonic in the first measurement in phase and in the second measurement in antiphase of the peaks of the fundamental current. For polyphase meters, the voltage circuit shall be energised in parallel and the current circuit in series.

3 Applicable for active energy meter only.

4 The polyphase meter shall measure and register within the variation in percentage error limits shown in Table 17 if one or the two phases of the 3-phase network are interrupted, provided the reference phase is available that is Y-phase for 3-phase 3-wire meters and neutral for 3-phase 4-wire meters. However the operation of the meter shall not be affected by such removal of reference phase.

5 This test does not apply to transformer operated meters. The test conditions are specified in Annex D.

Table 17 — Concluded

6 The test conditions are specified in 12.11.

7 A magnetic induction of external origin of 0.5 mT produced by a current of the same frequency as that of the voltage applied to the meter and under the most unfavourable conditions of phase and direction shall not cause a variation in the percentage error of the meter exceeding the values shown in Table 17. The test conditions are specified in 12.11.

8 The test conditions are specified in 12.9.3.

9 Such an accessory, enclosed in the meter case is energized intermittently, for example, the electromagnet of a multirate register.

The determination of the mean temperature coefficient for a given temperature shall be made over a 30°C temperature range 15°C above and 15°C below that temperature, the temperature shall not exceed the specified operating temperature range.

11.4 Starting and Running with No-Load

For these tests, the conditions and the values of the influence quantities shall be as stated in 12.10.1 except for any changes specified below.

11.4.1 Initial Start-up of the Meter

The meter shall be fully functional within 5s after the rated voltage is applied to meter terminals.

11.4.2 Running with No-Load

When the voltage is applied with no current flowing in the current circuit, the test output of the meter shall not produce more than one output pulse count.

For testing, see 12.13.

Table 18 Temperature Coefficient
(Clause 11.3)

Value of Current	Power Factor	Mean Temperature Coefficient for Meters of Class	
		1	2
(1)	(2)	(3)	(4)
From $0.1 I_b$ to I_{Max}	1	0.05	0.1
From $0.2 I_b$ to I_{Max}	0.5 lagging	0.07	0.15

11.5 Starting Current

The meter shall start and continue to register at the current shown in Table 19.

11.6 Meter Constant

Relation between the test output and the indication in the display shall comply with the marking on the name plate.

It is preferable that the connection to the auxiliary device is/are marked to indicate the correct method of connection, if these connections are made by means

of plugs and sockets, these connections should be irreversible.

Table 19 Starting Currents
(Clause 11.5)

Meter for (1)	Power Factor (2)	Class of Meter	
		1 (3)	2 (4)
Direct connection. Percentage of basic current I_b	1	0.4	0.5
Connection through current transformer. Percentage of basic current I_b	1	0.2	0.3

11.7 Repeatability of Error Test

Repeatability of error at 10 percent I_b and UPF load shall not exceed 0.5 for class 1 and 1.0 for class 2 as measured by the dispersion method (see 12.17).

12 TESTS AND TEST CONDITIONS

12.1 Test Conditions

All tests are carried out under reference conditions unless otherwise stated in the relevant clause.

12.2 Classification of Tests

The schedule and recommended sequence shall be as given in Table 20.

In case of modifications to the meter made after the type test and affecting only part of the meter, it will be sufficient to perform limited tests on the characteristics that may be affected by the modification.

12.2.1 Number of Samples and Criteria for Conformity

Type tests shall be applied to three test specimens; in the event of one specimen failing to comply in any respect, further three specimens shall be taken all of which shall comply with the requirements of the standard.

12.2.2 Schedule of Acceptance Tests

Required tests are marked with 'A' in Table 20.

12.2.2.1 Recommended sampling plan and criteria for acceptance

A recommended sampling plan and the criteria for acceptance of the lot are given in Annex H.

12.2.3 Schedule of Routine Tests

Required tests are marked with 'R' in Table 20.

12.3 Test of Mechanical Requirements

12.3.1 Shock Test

The test shall be carried out as per IS 9000 (Part 7/ Sec 1 to 5) under the following conditions:

Table 20 Schedule of Type Tests
(Clauses 12.2, 12.2.2 and 12.2.3)

Sl No. (1)	Test (2)	Clause Reference (3)	A (4)	R (5)
1	Test of Insulation Properties	12.7.6		
1.1	Impulse voltage test	12.7.6.2		
1.2	ac High voltage test	12.7.6.3	A	R
1.3	Insulation test	12.7.6.4	A	R
2	Test of Accuracy Requirements	12.10		
2.1	Test on limits of error	11.11	A	R
2.2	Interpretation of test results	12.16		
2.3	Test of meter constant	12.15	A	
2.4	Test of starting condition	12.14	A	R
2.5	Test of no-load condition	12.13	A	R
2.6	Test of ambient temperature influence	12.12		
2.7	Test of repeatability of error	12.17	A	
2.8	Test of influence quantities	12.11		
3	Test of Electrical Requirement	12.7		
3.1	Test of power consumption test	12.7.1	A	
3.2	Test of influence of supply voltage	12.7.2		
3.3	Test of influence short-time overcurrents	12.7.3		
3.4	Test of influence of self heating	12.7.4		
3.5	Test of influence of heating	12.7.5		
3.6	Test of influence of immunity to earth fault	12.8		
4	Test for Electromagnetic Compatibility	12.9		
4.1	Radio interference measurement	12.9.5		
4.2	Fast transient burst test	12.9.4		
4.3	Test of immunity to electrostatic discharges	12.9.2		
4.4	Test of immunity to electromagnetic HF field	12.9.3		
5	Test for Climatic Influences	12.6		
5.1	Dry heat test	12.6.1		
5.2	Cold test	12.6.2		
5.3	Damp heat cyclic test	12.6.3		
6	Test for Mechanical Requirements	12.3		
6.1	Vibration test	12.3.2		
6.2	Shock test	12.3.1		
6.3	Spring hammer test	12.3.3		
6.4	Protection against penetration of dust and water	12.5		
6.5	Test of resistance to heat and fire	12.4		

A = Acceptance Test; R = Routine Test

- Meter in non-operating condition, without the packing
- Half-sine pulse
- Peak acceleration : 40 g (400 m/s²)
- Duration of the pulse : 18 ms
- Number of shock : two in both direction of three mutual perpendicular axes (Total of 12 shocks).

After the test, the meter shall show no damage or change of information. After the test, variation in percentage error shall not exceed the 50 percent of accuracy class index at I_b , $0.05 I_b$ and I_{Max} (at $\cos \phi = 1$)

12.3.2 Vibration Test

The test shall be carried out as per IS 9000 (Part 8) under the following conditions :

- Meter in non-operation condition without the packing
- Frequency range : 10 - 150 - 10 Hz.
- Transition frequency : 60 Hz.
- $f < 60$ Hz constant amplitude of movement 0.15 mm
- $f > 60$ Hz constant acceleration 2 g ($1g = 9.8$ m/s²)
- Single point control
- Number of sweep cycles per axis : 10

NOTE— 10 sweep cycles = 75 min

After the test the meter shall show no damage or change of the information. After the test variation in percentage error of the meter error shall not exceed 50 percent of class index at $0.05 I_b$, basic current and maximum current (at $\cos \phi = 1$).

12.3.3 Spring Hammer Test

The mechanical strength of the meter case shall be tested with a spring hammer (IEC 60068-2-75 (1997) Environmental testing — Part 2-75: Tests — Test Eh: Hammtser test).

The meter shall be mounted in its normal working position and the spring hammer shall act on the outer surfaces of the meter cover including windows and on the terminal cover with a kinetic energy of $0.22 \text{ Nm} \pm 0.05 \text{ Nm}$.

The result of the test is satisfactory if the meter case and terminal cover do not sustain damage which could affect the function of the meter and it is not possible to touch live parts. Slight damage which doesn't impair the protection against indirect contact or the penetration of solid objects, dust and water is acceptable.

12.4 Test of Resistance to Heat and Fire

The test shall be carried out according to IS 11000 (Part 2/Sec 1), with the following temperatures:

- Terminal block : $960^\circ\text{C} \pm 15^\circ\text{C}$
- Terminal cover and meter case : $650^\circ\text{C} \pm 10^\circ\text{C}$
- Duration of application : $30 \text{ s} \pm 1 \text{ s}$.

The contact with the glow-wire may occur at any random location. If the terminal block is integral with the meter base, it is sufficient to carry out the test only on the terminal block.

12.5 Test of Protection Against Penetration of Dust and Water

The test shall be carried out according to IS 12063 under the following conditions:

- a) Protection against penetration of dust
 - Meter in non-operating condition and mounted on an artificial wall
 - The test should be conducted with sam-

ple lengths of cable (exposed ends sealed) of the types specified by the manufacturer in place.

First characteristic digit : 5 (IP 5X).

Any ingress of dust only be in a quantity not impairing the operation of the meter, and not impairing its dielectric strength (insulating strength).

For testing, see 12.7.6.4.

- b) Protection against penetration of water
 - Meter in non-operating condition

Second characteristic digit : 1 (IP X 1)

Any ingress of water must only be in a quantity not impairing the operation of the meter, and not impairing its dielectric strength (insulating strength).

For testing, see 12.7.6.4.

12.6 Test for Climatic Influences

After each of the climatic tests, the meter shall show no damage or change of the information . These tests should not affect the functioning of the meters.

12.6.1 Dry Heat Test

The test shall be carried out according to relevant section of IS 9000 (Part 3/Sec 1 to 5). Under the following conditions :

- Meter in non-operating condition
- Temperature : $+ 70 \pm 2^\circ\text{C}$
- Duration of the test : 72 h

12.6.2 Cold Test

The test shall be carried out according to relevant section of IS 9000 (Part 2/Sec 1 to 4) under the following conditions:

- Meter in non-operating condition
- Temperature : $-25 \pm 2^\circ\text{C}$
- Duration of the test : 72 hours

12.6.3 Damp Heat Cycle Test

The test shall be carried out according to relevant section of IS 9000 (Part 5/Sec 1 and 2) under the following conditions:

- Meter in operating condition
- Voltage and auxiliary circuits energised with reference voltage
- Without any current in the current circuits
- Upper temperature $40^\circ\text{C} \pm 2^\circ\text{C}$
- No special precautions shall be taken regarding the removal of surface moisture
- Duration of test : 6 cycles

24 hours after the end of this test the meter shall be submitted to the following tests :

- a) An insulation test according to 12.7.6.4; and
- b) A functional test. The meter shall show no damage or change of information.

The damp heat test also serves as a corrosion test. The result is judged visually. No trace of corrosion likely to affect the functional properties of the meter shall be apparent.

12.7 Test of Electrical Requirements

12.7.1 Test of Power Consumption

The power consumption in the voltage and current circuit shall be determined at reference values of the influencing quantities given in 12.10.1 by any suitable method. The overall accuracy shall be better than 5 percent.

12.7.2 Test of Influence of Supply Voltage

The test shall be carried out under the following conditions:

- Meter in operating condition
- Voltage and auxiliary circuits energised with reference voltage
- Without any current in the current circuits
- a) Voltage interruptions of $V_{ref} = 100$ percent
 - Interruption time : 1 s
 - Number of interruptions : 3
 - Restoring time between interruptions : 50 ms
 (See also Annex E.)
- b) Voltage interruption of $V_{ref} = 100$ percent
 - Interruption time : 20 ms
 - Number of interruptions : 1
 (See also Annex E.)
- c) Voltage dips of $V_{ref} = 50$ percent
 - Dip time : 1 min
 - Number of dips : 1
 (See also Annex E.)

For requirement, see 9.2.2.

12.7.3 Test of Influence of Short-time Overcurrents

The test circuit shall be practically non-inductive.

After the application of the short-time overcurrent with the voltage maintained at the terminals, the meter shall be allowed to return to the initial temperature with the voltage circuit(s) energised (about 1 h).

For requirement, see 9.2.3.

12.7.4 Test of Influence of Self-Heating

The test shall be carried out as follows :

After the voltage circuits have been energised

at reference voltage for at least 2 h, meters without any current in the current circuits, the rated maximum current shall be applied to the current circuits. The meter error shall be measured at unity power factor immediately after the current is applied and then at intervals short enough to allow a correct drawing to be made of the curve of error variation as a function of time.

The test shall be carried out for at least 1 h and in any event until the variation of error during 20 min does not exceed 0.1 percent or the measurement uncertainties whichever is greater.

The same test shall be carried out than at 0.5 (lagging) power factor.

The variation of error, measured as specified, shall not exceed the values given in Table 13.

12.7.5 Test of Influence of Heating

With each current circuit of the meter carrying rated maximum current and with each voltage circuits (and with those auxiliary, voltage circuits which are energised for periods of longer duration than their thermal time constants) carrying 1.2 times the reference voltage, the temperature rise of the external surface shall not exceed by more than 20 K, with the ambient temperature between 25°C to 45°C.

During the test, the duration of which shall be 2 h, the meter shall be not exposed to draught or direct solar radiation.

After the test, the meter shall show no damage and shall comply with the dielectric tests of 12.7.6.4.

12.7.6 Test of Insulation Properties

12.7.6.1 General test conditions

The test shall be carried out only on a complete meter with its cover (except when indicated hereafter) and terminal cover, the terminal screws being screwed down to maximum applicable conductor fitted in the terminals. Test procedure shall be in accordance with IS 2071 (Part 1).

The impulse voltage tests shall be carried out first and the ac high voltage tests afterwards.

During type tests, the dielectric property tests are considered to be valid only for the terminal arrangement of the meter which has undergone the tests. When the terminal arrangement differ, all the dielectric property tests shall be carried out for each arrangement.

For the propose of these tests, the 'earth' has the following meaning:

- a) When the meter case is made of metal, the

earth is the case itself placed on a flat conducting surface.

- b) When the meter case or only a part of it is made of insulating material, the earth is a conductive foil wrapped around the meter, touching all accessible conductive parts and connected to the flat conducting surface on which the meter base is placed. Where the terminal cover makes it possible, the conductive foil shall approach the terminals and holes for the conductors within a distance of not more than 2 cm.

During the impulse and the ac voltage tests, the circuits which are not under test are connected to the earth as indicated hereafter. A flashover (capacitance discharge) is not necessarily a criterion of failure as this may occur in a position that does not damage and the manufacturer shall decide, whether or not to eliminate the cause, provided other criteria of acceptance are met.

In this sub-clause, the expression all the terminals means the whole set of the terminals of the current circuits, voltage circuits and, if any, auxiliary circuits having a reference voltage over 40 V.

These shall be made in normal conditions of use. During the test, the quality of the insulation shall not be impaired by dust or abnormal humidity.

Unless otherwise specified, the normal conditions for insulation test are:

- ambient temperature 20°C to 35°C
- relative humidity 45 percent to 95 percent
- atmospheric pressure 86 to 106 kPa (860 mbar to 1 060 mbar)

12.7.6.2 Impulse voltage test

The impulse of 5kV is applied ten times with one polarity and then repeated with the other polarity. The minimum time between the impulses shall be 3 s. The waveform and the generator characteristics shall be in accordance with IEC 61000-4-5 (1995-03) 'Electromagnetic compatibility (EMC) — Part 4: Testing and measurement techniques — Section 5 Surge immunity test'.

a) Impulse voltage tests for circuits and between the circuits

The test shall be made independently on each circuit (or assembly of circuits) which are insulated from the other circuits of the meter in normal use. The terminals of the circuits which are not subjected to impulse voltage shall be connected to earth.

Thus, when in normal use the voltage and the

current circuits of a measuring elements are connected together, the test shall be made on the whole. The other end of the voltage circuit shall be connected to earth and impulse voltage shall be applied between the terminal of the current circuit and earth. When several voltage circuits of a meter have a common point, this point shall be connected to earth and the impulse voltage successively applied between each of the free ends of the connections (or the current circuit connected to it) and earth.

When in normal use, the voltage and the current circuits of the same measuring element are separated and appropriately insulated (for example, each circuit connected to measuring transformer) the test shall be made separately on each circuit.

During the test of a current circuit, the terminals of the other circuits shall be connected to earth and the impulse voltage shall be applied between one of the terminals of the current circuit and earth. During the test of a voltage circuit, the terminals of the other circuits and one of the terminals of the voltage circuit under test shall be connected to earth and the impulse voltage shall be applied between the other terminal of the voltage circuit and earth.

The auxiliary circuits intended to be connected either directly to the mains or to the same voltage transformers as the meter circuits and with a reference voltage over 40 V shall be subjected to the impulse voltage test in the same conditions as those already given for voltage circuits. The other auxiliary circuits shall not be tested.

b) Impulse voltage test of electric circuits relative to earth

All the terminals of the electric circuits of the meter, including those of the auxiliary circuits with a reference voltage over 40 V, shall be connected together.

The auxiliary circuits with a reference voltage below or equal to 40 V shall be connected to earth.

The impulse voltage shall be applied between all the electric circuits and earth.

12.7.6.3 ac Voltage test

The ac voltage test shall be carried out in accordance with Table 21 for type test and acceptance test of new meters. For any subsequent test, the voltage applied shall be 80 percent of the test voltage indicated in Table 21.

Table 21 ac Voltage Tests
(Clause 12.7.6.3)

Test Voltage (r.m.s.) (1)	Points of Application of the Test Voltage (2)
2 kV	A) Test to be carried out with the case closed, and terminal cover in place a) Between, on the one hand, all the current and voltage circuits as well as the auxiliary circuits whose reference voltage is over 40 V, connected together, and, on the other hand, earth b) Between circuits not intended to be connected together in service
4 kV (For test in item a)	B) Additional tests for insulating encased meters: a) Between, on the one hand, all the current and voltage circuits as well as the auxiliary circuits whose reference voltage is over 40V, connected together, and, on the other hand, earth (see Note 1) b) A visual inspection for compliance with the conditions of 6.7
40 V (for test in item c)	c) Between, on the one hand, all conductive parts inside the meter, connected together and, on the other hand, all conductive parts outside the meter case that are accessible with the test finger connected together (see Note 2)

NOTES

1 The test in item (a) of Part B is to be carried out, with the case closed, the cover and terminal cover in place.

2 The test in item (c) of Part B is not necessary, if test in item (b) leaves no doubt.

The test voltage shall be substantially sinusoidal, having a frequency between 45 Hz and 55 Hz, and applied for one minute. The power source shall be capable of supplying at least 500 VA.

During the test no flashover, disruptive discharge, puncture shall occur.

During the tests relative to earth the auxiliary circuits with reference voltage equal to or below 40 V shall be connected to earth.

12.7.6.4 Insulation resistance test

The insulation resistance test shall be carried out in accordance with Table 22. The voltage shall be applied for a minimum of one minute or more for the pointer of the insulation tester to have come practically to rest.

12.8 Test of Immunity to Earth Fault

It shall be verified that the earth fault requirements as fixed under 9.6 are satisfied. For test diagram, see Annex F.

Table 22 Insulation Resistance Test
(Clause 12.7.6.4)

Test Voltage (1)	Points of Application of the Test Voltage (2)	Insulation Resistance (3)
500 ± 50 V dc	a) Between, on the one hand, all the current and voltage circuits as well as the auxiliary circuits whose reference voltage is over 40 V, connected together, and, on the other hand, earth b) Between circuits not intended to be connected together in service	5 MΩ 50 MΩ

NOTE — Where two or more voltage circuits are permanently joined together, the combination may be treated as one circuit for this test.

12.9 Test for Electromagnetic Compatibility (EMC) and Electromagnetic Interference (EMI)

12.9.1 General Test Conditions

For all these tests, the meter shall be in its normal working position with the cover and terminal cover in place. All parts intended to be earthed shall be earthed.

After these tests, the meter shall show no damage or change of information..

12.9.2 Test for Immunity to Electrostatic Discharge (ESD)

The test shall be carried out according to IEC 61000-4-2 (1995-01) 'Electromagnetic compatibility (EMC) — Part 4 : Testing and measurement techniques — Section 2: Electrostatic discharge immunity test'. Under the following conditions :

- Contact Discharge
- Test Voltage : 8kV
- Test severity level : 4
- Number of discharges : 10
- Voltage and auxiliary circuits energised with reference voltage
- Without any current in the current circuits and the current terminal should be open circuit.

The application of the electrostatic discharge shall not produce a change in the register of more than 0.01 kWh and the test output shall not produce a signal equivalent to more than 0.01 kWh. These values are based on the rated current of 5A and 100 V of the meter. For other voltage and current ratings the value 0.01 kWh has to be converted accordingly.

12.9.3 Test for Immunity to Electromagnetic HF Fields

The test shall be carried out according to IEC 61000-4-3 (1995-03) 'Electromagnetic compatibility (EMC) — Part 4: Testing and measurement techniques —

Section 3: Radiated, radio-frequency electromagnetic field immunity test' under the following conditions:

- Voltage and auxiliary circuits energised with reference voltage
 - Frequency band : 80 MHz to 1 000 MHz
 - Test field strength : 10 V/m
 - Test severity level : 4
- a) Without any current in the transformer circuits and the current should be open circuit. The application of the HF field shall not produce a change in the register of more than 0.01 kWh and the test output shall not produce a signal equivalent to more than 0.01 kWh. These values are based on the rated current of 5A and 100 V of the meter. For the other voltage and current ratings the value 0.01 kWh has to be converted accordingly.
- b) With basic current I_b and power factor equal to unity, at sensitive frequencies or frequencies of dominant interest, the variation of error shall be within the limit given in Table 17.

12.9.4 Fast Transient Burst Test

The test shall be carried out according to IEC 61000-4-4 (1995-01) 'Electromagnetic compatibility (EMC) — Part 4: Testing and measurement techniques — Section 4: Electrical fast transient /burst immunity test under the following conditions :

- Meter in operating condition
- Voltage and auxiliary circuits energised with reference voltage
- Without any current in the current circuits and the current terminals should be open circuit
- Test voltage : 4 kV
- Test severity level : 3
- Duration of the test : minimum 60 s.

Test points are :

- a) Between the terminal of each circuit normally connected to the mains;
- b) Between any two independent circuits having reference voltages over 40 V; and
- c) Between each independent circuits having reference voltages over 40 V and earth.

During the test, there shall not be a change in the register of more than 0.01 kWh and the test output shall not produce a signal equivalent to more than 0.01 kWh. These values are based on the rated current of 5A and 100 V of the meter. For the other voltage and current ratings the value 0.01 kWh has to be converted accordingly.

12.9.5 Radio Interference Measurement

The test for radio interference shall be carried out for the frequencies from 0.15MHz to 30 MHz and for the frequencies form 30 MHz to 300 MHz as per IS 6842.

12.10 Test of Accuracy Requirements

12.10.1 General Test Conditions

Determination of meter errors for the purpose of verification of accuracy requirement (11) and verification of such errors for the purpose of other requirements shall be carried out in a meter testing station having Meter Testing Equipment of relevant accuracy class as laid down in IS 12346.

The following test conditions shall be maintained :

- a) The meter shall be tested in its case with cover in position; all parts intended to be earthed shall be earthed;
- b) Before any tests are made, the circuits shall have been energised for a time to reach thermal stability;
- c) In addition, for polyphase meters;
 - The phase sequence shall be as marked on the diagram of connections;
 - The voltages and currents shall be substantially balanced (*see* Tables 23 and 24);
- d) The minimum test period at any test point shall contain sufficient number of cycles (more than 1 000) to take care instantaneous power variation within a cycle. The maximum test period is however determined by homogeneity and resolution of test output (*see* 6.11); and
- e) The reference condition shall be as specified in Table 24.

Table 23 Voltage and Current Balance

(Clauses 12.10.1 and 12.11)

SI No.	Polyphase Meters	Class of Meters	
		1	2
(1)	(2)	(3)	(4)
i)	Each of the voltages between line and neutral or between any two lines shall not differ from the average corresponding voltage by more than	± 1%	± 1%
ii)	Each of the currents in the current circuit shall not differ from the average current by more than	± 2%	± 2%
iii)	The phase displacements of each of these currents from the corresponding line-to-neutral voltage, irrespective of the power factor, shall not differ from each other by more than	2 deg	2 deg

Table 24 Reference Conditions
(Clause 12.10.1)

SI No. (1)	Influence Quantity (2)	Reference Value (3)	Permissible Tolerances (4)
i)	Ambient temperature (see Note 1)	Reference temperature or in its absence 27°C	± 2°C
ii)	Voltage	Reference voltage (see Note 3)	± 1 percent
iii)	Frequency	Reference frequency (see Note 3)	± 0.3 percent
iv)	Waveform	Sinusoidal voltage and current	Distortion factor less than 2 percent
v)	Magnetic induction of external origin at the reference frequency	Magnetic induction equal to zero (see Note 4)	Induction value which causes a variation of error not greater than 0.2 percent (class 1) and 0.3 percent (class 2) but in any case should not be greater than 0.05mT (see Note 2)

NOTES

1 If the tests are made at a temperature other than the reference temperature, including permissible tolerances, the results shall be corrected by applying the appropriate temperature coefficient of the meter.

2 The test consists of:

a) For a single-phase meter, determining the errors at first with the meter normally connected to the mains and then after inverting the connections to current circuits as well as to the voltage circuits. Half of the difference between the two errors is the value of the variation of error. Because of the unknown phase of the external field, the test has to be made at $0.1 I_b$ at unity power factor and $0.2 I_b$ at 0.5 lag power factor.

b) For a three-phase meter, making three measurements at $0.1 I_b$ at unity power factor, after each of which the connections to the current circuits and to voltage circuits are changed over 120° while the phase sequences is not altered. The greatest difference between each of the errors so determined and their average value is the value of the variation of error.

3 The reference conditions for voltage and frequency apply to both the measuring circuit and the auxiliary supply(ies).

4 This magnetic induction is that at the place of test without the presence of the meter and its connections.

12.11 Test of Influence Quantities

It shall be verified that the requirements of influence quantities as fixed under 11.1 and 11.2 are satisfied. Test for variation caused by one influence quantity should be performed independently with all other influence quantities at their reference conditions (see Table 23).

The continuous magnetic induction may be obtained by using the electromagnet according to Annex G, energised with a dc current. This magnetic field shall be applied to all accessible surfaces of the meter when it is mounted as for normal use. The value of the magnetic- motive force, to be applied shall be 1 000 ampere-turns.

The magnetic induction may be obtained by placing the meter in the centre of a circular coil, 1 m in mean diameter, of square section of small radial thickness relative to the diameter, and having 400 ampere-turns.

12.12 Test of Ambient Temperature Influence

It shall be verified that the ambient temperature influence as fixed under 11.3 is satisfied.

12.13 Test of No-Load Condition

For this test the current circuit must be open circuit and a voltage of 115 percent of the reference voltage shall be applied to the voltage circuits.

The minimum test period shall be 20 times the actual test period of starting current, the maximum test period shall be limited to 200 min.

During this test the test output of the meter shall not produce more than one output pulse/count.

12.14 Test of Starting Conditions

It shall be verified that the starting requirements as fixed under 11.5 are satisfied.

12.15 Test of Meter Constant/Registration

The requirement of 11.6 shall be verified at one test point, preferably at I_{Max} UPF.

Although this verification is not required for meters having test output in the form of high resolution register, a long period registration test shall be performed at this test points to verify conformity of registration error, as indicated by the display of the meter and as distinct from any other external display used for testing purpose, within the limits specified in Table 15.

12.16 Limits of Error and Interpretation of Test Results

- Limits of error as specified in 11.1 shall be verified.
- Certain test results may fall outside the limits indicted in Tables 15 and 16. Owing to uncertainties of measurements and other parameters capable of influencing the measurements. However, if by one displacement of the zero line parallel to itself by no more than the limits indicated in Table 25, all the test result are brought within the limits indicated in Tables 15 and 16, the meter type shall be considered acceptable.
- If the tests are made at a temperature other than the reference temperature, including permissible tolerances, the results shall be corrected by applying the appropriate temperature coefficient of the meter.

Table 25 Interpretation of Test Results
(Clause 12.16)

	Class of Meter	
	1	2
Permissible displacement of the zero line, percent	0.5	1.0

12.17 Repeatability of Error Test

Test shall be carried out at $0.05I_b$, I_b at UPF load under reference test conditions. Twenty error samples shall be taken at time-intervals of 30 min. Identical test condition shall be maintained through out the test.

For acceptance test six error tests may be carried out at time interval of at least 5 min.

ANNEX A

(Clause 2)

LIST OF REFERRED INDIAN STANDARDS

IS No.	Title	IS No.	Title
1401 : 1970	Accessibility test probes (<i>first revision</i>)	11000 (Part 2/ Sec 1) : 1984	Fire hazard testing: Part 2 Test methods, Section 1 Glow-wire test and guidance
2071 (Part 1) : 1993	High voltage testing: Part 1 General definitions and test requirements	11731 (Part 1): 1986	Methods for tests for determination of flammability of solid electrical insulating material when exposed to an igniting source: Part 1 Horizontal specimen method
4905 : 1968	Methods for random sampling	12032 series	Graphical symbols for diagrams in the field of eletrotechnology
6842 : 1997	Limits of electromagnetic interference	12063 : 1987	Classification of degrees of protection provided by enclosures of electrical equipment.
9000	Basic environmental testing procedure for electronic and electrical items :	12346 : 1988	Testing equipment for ac electrical energy meters
(Part 2/Sec 1 to 4) : 1977	Cold test	12360 : 1988	Voltage bands for electrical installations including preferred voltages and frequency
(Part 3/Sec 1 to 5) : 1977	Dry heat test	13010 : 1990	ac Watthour meters, class 0.5, 1 and 2
(Part 5/Sec 1 and 2) : 1981	Damp heat (cyclic) test		
(Part 7/Sec 1) : 1979	Impact test (Section 1 to 5 in one volume)		
(Part 8) : 1981	Vibration (sinusoidal) test		

ANNEX B

(Clause 6.4)

**RECOMMENDED METHODS OF CONNECTION OF CURRENT/VOLTAGE
CIRCUIT CONDUCTORS TO METER TERMINALS**

B-0 The current conductors/potential circuit conductors of a meter shall be conducted to its respective terminals inside the meter base adopting any of the following recommended methods so as to ensure satisfactory, durable and adequate contact surfaces between the conductors and the terminals.

B-1 The ends of current circuit lead/potential circuit lead wound from round section wire or flat strip shall be formed into loops. Each complete loop shall be accommodated between a flats section of the top end of a current/potential terminal and a flat rectangular or circular washer plate having central hole, the three being pressed together by a screw having sufficiently large head to cover the loop. The current/potential terminal shall have thread for fixing of the screw. The washer plate shall be of good conducting material and shall have spring action.

B-2 Current circuit leads having rectangular section conductors of sufficient width shall have flattened

ends. Each end shall be accommodated between a flat section of the top end of a current terminal and a flat rectangular or circular washer plate, the three being pressed together by a screw having sufficiently large head to cover the flattened end of the current circuit lead coil. The washer plate shall have holes for clear passage of the screw and the current terminals shall have thread for fixing of the screw. The washer plate shall be of good conducting material and shall have spring action. In order to ensure proper gripping of the screw head, the central hole of the washer plate and the corresponding part of the screw head may be counter sunk.

B-3 In case where methods B-1 or B-2 cannot be satisfactory adopted, specially where a number of rectangular section conductors or strips or wires have been used, the ends of current circuit leads shall be terminated into elongated soldering-cum-crimping sockets having machined flat bottom ends material as that of the current terminal.

ANNEX C

(Clause 8.2)

RELATIONSHIP BETWEEN AMBIENT AIR TEMPERATURE AND RELATIVE HUMIDITY

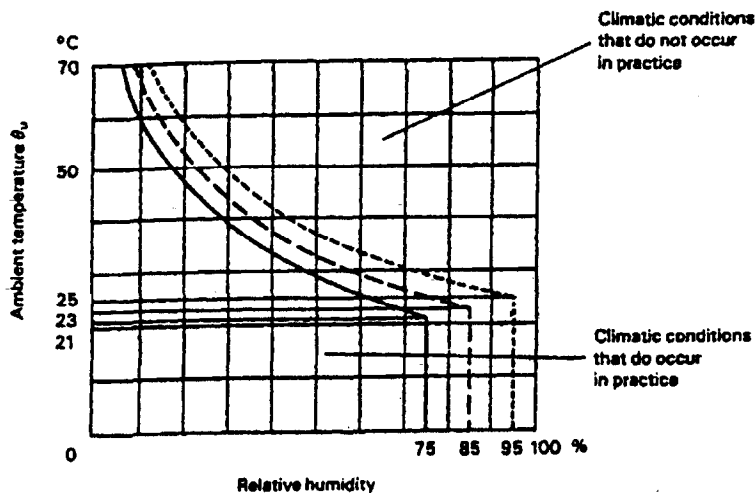

- Limits for each of 30 days spread in a natural manner over one year
- - - - Limits occasionally reached on other days
- Annual mean

ANNEX D
(Table 17, Note 5)

TEST CIRCUIT DIAGRAM FOR DC EVEN HARMONICS AND SUB-HARMONICS

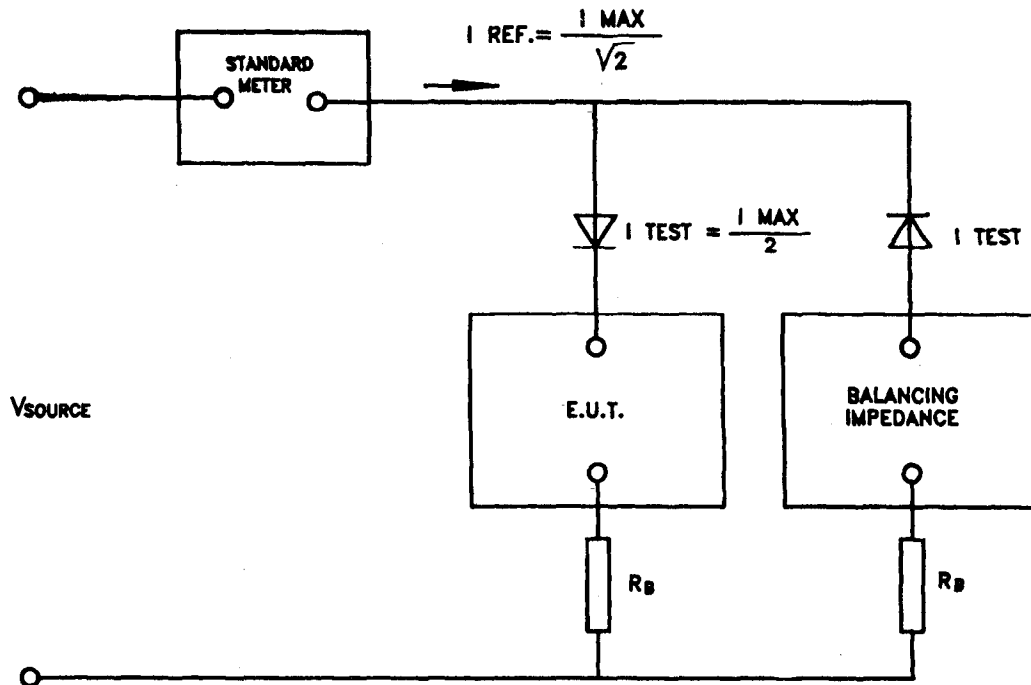

NOTES

- 1 The balancing impedance shall be equal to the impedance of the equipment under test (EUT) to ensure the measurement accuracy.
- 2 The balancing impedance could most conveniently be a meter of the same type as the EUT.
- 3 The rectifier diodes shall be of the same type.
- 4 To improve the balancing condition an additional resistor R_B can be introduced in both paths. Its value should be approximately 10 times the value of the EUT.
- 5 The influence of the dc components and even harmonics in the ac current circuit shall be checked at $0.5 I_{MAX}$. To achieve this test condition the ac current I_{REF} through the standard meter shall be reduced by a factor of $\sqrt{2}$ relative to the I_{MAX} given on the name-plate of the meter (EUT).

ANNEX E
(Clause 12.7.2)

VOLTAGE WAVE FROM THE TESTS OF INFLUENCE OF SUPPLY VOLTAGE

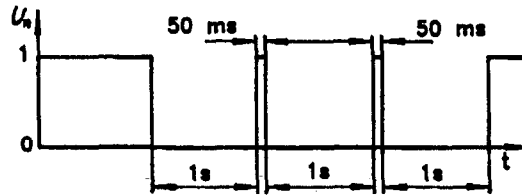

FIG. E1 VOLTAGE INTERRUPTIONS OF $\Delta U = 100$ PERCENT, 1 s

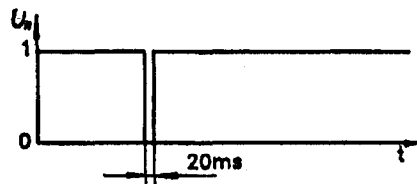

FIG. E2 VOLTAGE INTERRUPTIONS OF $\Delta U = 100$ PERCENT, 20 ms

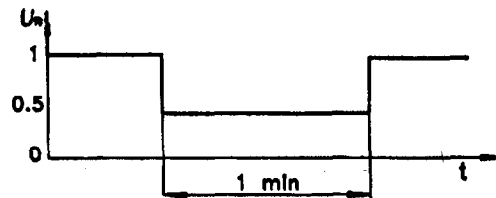
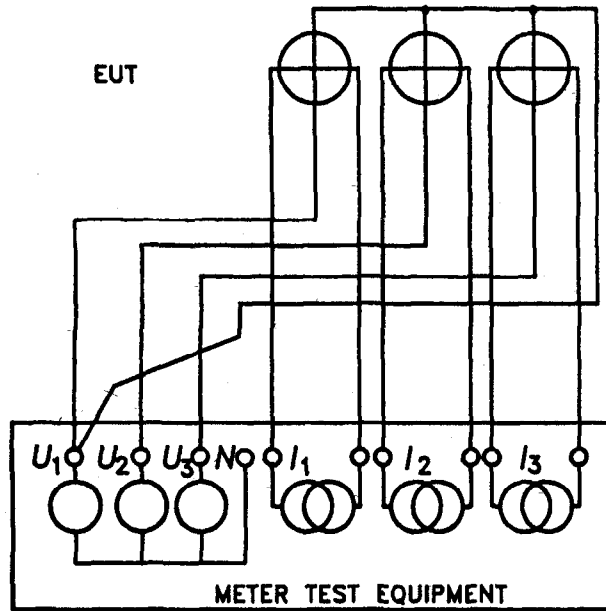

FIG. E3 VOLTAGE DIPS OF $\Delta U = 50$ PERCENT

ANNEX F

(Clauses 9.6 and 12.8)

TEST CIRCUIT DIAGRAM FOR THE TEST OF IMMUNITY TO EARTH FAULT



CIRCUIT TO SIMULATE EARTH FAULT CONDITION IN PHASE 1

VOLTAGE AT THE METER UNDER TEST

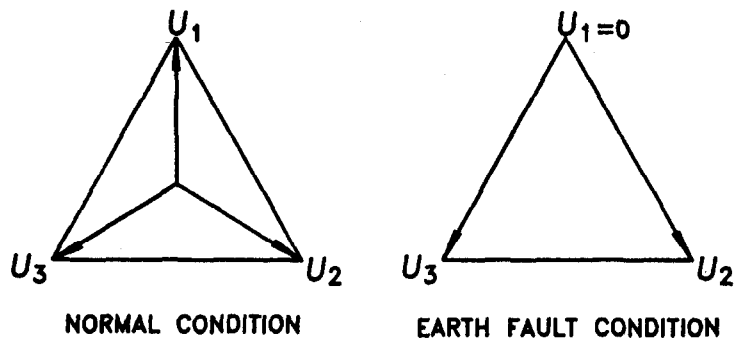

ANNEX G
(Clause 12.11)

**ELECTROMAGNET FOR TESTING THE INFLUENCE OF
EXTERNALLY-PRODUCED MAGNETIC FIELDS**

All dimensions in millimetres.

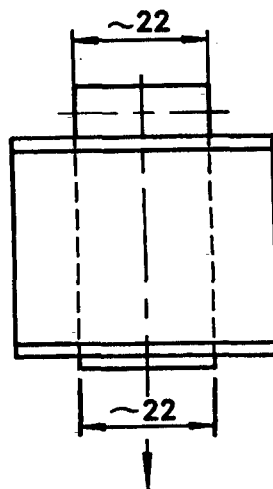
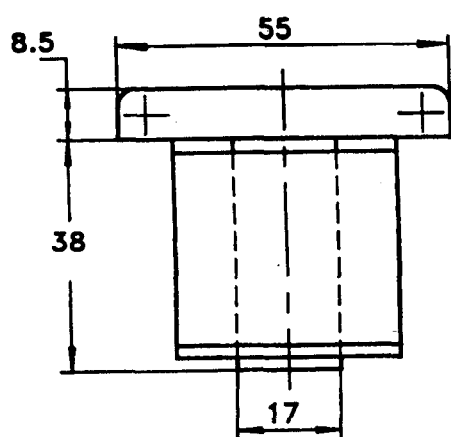

METER UNDER TEST

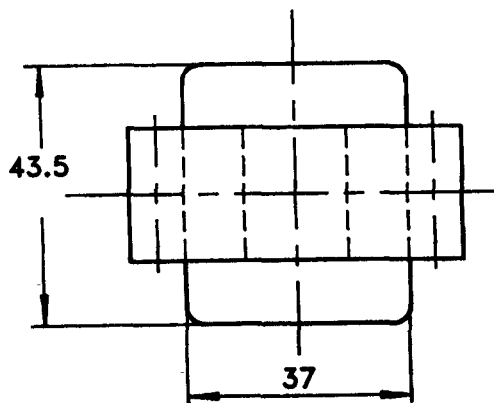

Examples of winding : 500 turns, 0.6 ϕ /0.28 mm²
Core lamination : 1.0 W/kg

ANNEX H

(Clause 12.2.2.1)

RECOMMENDED SAMPLING PLAN

H-1 LOT

H-1.1 In any consignment, all the meters of the same type and rating manufactured by the same factory during the same period shall be grouped together to constitute a lot.

H-1.2 Sample shall be tested from each lot for ascertaining the conformity of the meters to the requirements of specified acceptance test.

H-2 SCALE OF SAMPLING

H-2.1 The number of meters to be selected from the lot depends upon the size of the lot and shall be in accordance with Table 26.

Table 26 Sampling Plan

Lot Size (1)	$N_1^{1)}$ (2)	$N_2^{2)}$ (3)	(N_1+N_2) (4)	C_1 (5)	C_2 (6)
Up to 300	8	—	8	0	—
301 to 500	13	13	26	0	2
501 to 1 000	20	20	40	0	3
1 001 and above	32	32	64	1	4

¹⁾Size of the first sample.
²⁾Size of the second sample.

H-2.2 The meters shall be taken at random from the lot. The procedure given in IS 4905 may be adapted.

H-3 NUMBER OF TESTS AND CRITERIA FOR ACCEPTANCE

H-3.1 Test of No-Load Condition and Starting Condition

A sample of N_1 meters selected according to col 2 of Table 26 shall be tested for the above tests. Any meter

failing in any one of these tests shall be considered defective. If the number of defectives found in the sample is less than or equal to C_1 , the lot shall be considered to be conforming to these tests. If the number of defectives is greater than or equal to C_2 , the lot shall be considered as not conforming to these tests. If the number of defectives is between C_1 and C_2 , a further sample of N_2 meters shall be taken according to col 3 of Table 26 and subjected to these tests. If the number of defectives in two samples combined is less than C_2 , the lot shall be considered as conforming to these tests, otherwise rejected.

H-3.2 Tests of insulation resistance, ac voltage tests, test of power consumption, test of meter constant/registration, limits of error and interpretation of test results and adjustment (if required).

From the sample of meters which have been drawn according to **H-3.1** and those that have passed all tests of **H-3.1**, a sample of 8 meters shall be tested, all of which shall pass for conformity to these tests. If any of the meters fails in any of these tests, the whole lot shall be declared not conforming to the requirements of these tests.

H-3.3 Tests for Repeatability of Error

Above tests shall be carried out on 3 samples selected from above 8 meters under **H-3.2** and shall be tested for repeatability of error tests separately. If any one of the meters fails the whole lot shall be declared not conforming to the requirements of these tests.

H-3.4 The lot shall be considered as conforming to this specification, if provisions of **H-3.1**, **H-3.2** and **H-3.3** are satisfied.

Bureau of Indian Standards

BIS is a statutory institution established under the *Bureau of Indian Standards Act, 1986* to promote harmonious development of the activities of standardization, marking and quality certification of goods and attending to connected matters in the country.

Copyright

BIS has the copyright of all its publications. No part of these publications may be reproduced in any form without the prior permission in writing of BIS. This does not preclude the free use, in the course of implementing the standard, of necessary details, such as symbols and sizes, type or grade designations. Enquiries relating to copyright be addressed to the Director (Publication), BIS

Review of Indian Standards

Amendments are issued to standards as the need arises on the basis of comments. Standards are also reviewed periodically; a standard along with amendments is reaffirmed when such review indicates that no changes are needed; if the review indicates that changes are needed, it is taken up for revision. Users of Indian Standards should ascertain that they are in possession of the latest amendments or edition by referring to the latest issue of 'BIS Handbook' and 'Standards: Monthly Additions'.

This Indian Standard has been developed from Doc: No. ETD 13 (5019).

Amendments Issued Since Publication

Amend No.	Date of Issue	Text Affected

BUREAU OF INDIAN STANDARDS

Headquarters:

Manak Bhavan, 9 Bahadur Shah Zafar Marg, New Delhi 110002
Telephones: 323 01 31, 323 3375, 323 94 02

Telegrams: Manaksanstha
(Common to all offices)

Regional Offices:

	Telephone
Central : Manak Bhavan, 9 Bahadur Shah Zafar Marg NEW DELHI 110002	323 76 17, 323 38 41
Eastern : 1/14 C.I.T. Scheme VII M, V.I.P. Road, Kankurgachi CALCUTTA 700054	{ 337 84 99, 337 85 61 337 86 26, 337 91 20
Northern : SCO 335-336, Sector 34-A, CHANDIGARH 160022	{ 60 38 43 60 20 25
Southern : C.I.T. Campus, IV Cross Road, CHENNAI 600113	{ 235 02 16, 235 04 42 235 15 19, 235 23 15
Western : Manakalaya, E9 MIDC, Marol, Andheri (East) MUMBAI 400093	{ 832 92 95, 832 78 58 832 78 91, 832 78 92
Branches : AHMADABAD. BANGALORE. BHOPAL. BHUBANESHWAR. COIMBATORE. FARIDABAD. GHAZIABAD. GUWAHATI. HYDERABAD. JAIPUR. KANPUR. LUCKNOW. NAGPUR. PATNA. PUNE. RAJKOT. THIRUVANANTHAPURAM.	

AMENDMENT NO. 1 OCTOBER 2003
TO
IS 13779 : 1999 ac STATIC WATTHOUR METERS,
CLASS 1 AND 2 — SPECIFICATION
(First Revision)

(Page 7, clause 6.11, para 2) — Substitute the following for the existing:

‘Since the sequence of test output pulses may not be homogeneous, the manufacturer shall state the minimum number of pulse counts necessary to ensure that the error contribution due to such non homogeneity does not exceed 1/10th of the specified error limits at various points and consistent with the desired resolution.’

(Page 7, Table 5, col 3) — Substitute ‘3 × 110/√3 V or 3 × 63.5 V’ for ‘3 × 110 √33 × 240 V’.

(Page 8, clause 7.2) — Insert the following at the end of the text:

‘Standard connection diagrams are shown in Annex J.’

(Page 8, Table 7, col 2) — Substitute ‘-10°C to +55°C’ for ‘0°C to + 55°C’.

(Page 8, Table 7, col 2) — Substitute ‘-25°C to +60°C’ for ‘-10°C to + 60°C’.

(Page 8, Table 7, col 2) — Substitute ‘-25°C to +70°C’ for ‘-10°C to + 70°C’.

(Page 8, clause 9.1.1, Table 9, col 2) — Substitute ‘1.5 W and 10 VA’ for ‘1.5 W and 8 VA’.

(Page 9, clause 9.6) — Substitute the following for the existing clause:

‘9.6 Immunity to Earth/Phase Fault

This test applies to three-phase three element meters.

During test under a simulated earth/phase fault condition in one/two of the three lines, all voltages are increased to 1.1 times the nominal voltages during 4 h. The neutral terminal of the meter under test is disconnected from the ground terminal of the meter test equipment (MTE) and is connected to the MTE’s line at which the earth/phase fault has to be simulated (see Annex F).

In this way the two voltage elements of the meter under test which are not affected by the earth/phase fault are connected to 1.9 times the nominal phase voltages. During this test the current circuits are set to 50 percent of the rated I_b power factor 1 and symmetrical load. After the test, the meter shall show no damage and shall operate correctly.

The change of error measured when the meter is back at nominal working temperature shall not exceed the limits given in Table 14.’

(Page 9, Table 14, title) — Substitute the following for the existing title:

‘Table 14 Change of Error Due to Earth/Phase Fault’

[Page 11, Table 17, Sl No. (vi), col 2] — Substitute ‘DC and even harmonics in AC current circuit (see Note 5)’ for ‘dc component in ac current circuit (see Note 5)’.

[Page 11, Table 17, Sl No. (ix), col 5] — Substitute ‘2.0’ for ‘0.5’.

[Page 11, Table 17, Sl No. (ix), col 6] — Substitute ‘3.0’ for ‘1.0’.

[Page 11, Table 17, Sl No. (x)] — Insert the following at the end:

(1)	(2)	(3)	(4)	(5)	(6)
xi)	Continuous ‘abnormal’ magnetic induction of external origin (see Note 10)	I _b	1	4.0	4.0

Amend No. 1 to IS 13779 : 1999

(Page 11, Table 17, Note 5) — Insert the following at the end of existing sentence:

'The distortion factor of the voltage shall be less than 1%.'

(Page 11, Table 17, Note 9) — Insert the following new note at the end:

'10 The test conditions are specified in 12.11.'

(Page 12, clause 11.7, line 1) — Substitute the following for the existing line:

'Repeatability of error at 5 percent I_b and UPF load'

(Page 12, Table 20, Sl No. 3.6, col 2) — Substitute the following for the existing text:

'Test of immunity to earth/phase fault'

(Page 16, clause 12.8, title) — Substitute the following for the existing:

'12.8 Test of Immunity to Earth/Phase Fault'

(Page 16, clause 12.8, line 1) — Substitute the following for the existing line:

'It shall be verified that the earth/phase fault requirements as'

(Page 17, clause 12.9.4) — Substitute the following for the existing clause:

'12.9.4 Fast Transient Burst Test

The test shall be carried out according to IS 14700 (Part 4/Sec 4) under the following conditions:

a) Without any current in the current circuit and current terminals shall be open circuit.

- meter in operating condition;
- voltage and auxiliary circuits energized with reference voltage;
- test voltage on the current and voltage circuit: 4 kV;
- duration of the test : 60 s;
- tested as table-top equipment.

b) With basic current I_b and power factor equal to 1

- voltage and auxiliary circuits energized with reference voltage;
- test voltage on the current and voltage circuit: 2 kV;
- test voltage on the auxiliary circuits with a reference voltage over 40 V : 1 kV;
- duration of the test : a fast transient burst of 1 s commences the test, followed by a 300 s non-active period. The test cycle is then repeated until a minimum test time of 10 min has been completed (the actual test time will depend on the resolution of the meter register; a resolution of at least 0.4 % and 0.6 % is required from class 1 and class 2 respectively).
- tested as table top equipment

Test voltage applied between:

- The terminals of each circuit normally connected to mains;
- Any two independent circuits having reference voltage over 40 V; and
- Each independent circuit having reference voltage over 40 V and earth.

The qualifying conditions for the tests are:

- (i) In case (a) above: During the test, there shall not be a change in the register of more than 0.01 kWh and the test output shall not produce a signal equivalent to more than 0.01 kWh. These values are based on the rated current of 5A and reference voltage of 100 V of the meter. For the other voltage and current ratings the value of 0.01 kWh has to be converted accordingly.
- (ii) In case (b) above: The advancement in registration during this test shall not vary by more than 4% or 6% for meters of Class 1 and 2 respectively from a test under the same load conditions without application of the transients.'

(Page 18, clause 12.11, para 2) — Substitute the following for the existing text:

'The continuous magnetic induction of 67 milli Tesla $\pm 5\%$ (see Note 6 under Table 17) shall be obtained at a distance of 5 mm from the surface of the pole, by using the electromagnet according to Annex G energized with a dc current. The magnetic field shall be applied to all surfaces of the meter. The value of the magneto-motive force to be applied shall generally be 1 000 ampere turns.'

(Page 18, clause 12.11, para 2) — Insert the following new para after para 2:

'The continuous 'abnormal' magnetic induction of 0.2 Tesla $\pm 5\%$ (see Note 10 under Table 17) shall be obtained at a distance of 5 mm from the surface of the pole, by using the electromagnet according to Annex G energized with a dc current. The magnetic field shall be applied to all surfaces of the meter. The value of the magneto-motive force to be applied shall generally be 10 000 ampere turns.'

(Page 18, clause 12.11, para 3, line 1) — Substitute the following for the existing line:

'The magnetic induction (see Note 7 under Table 17) shall be obtained by placing'

(Page 19, Annex A) — Substitute 'IS 12346 : 1999' for 'IS 12346 : 1988'.

(Page 19, Annex A) — Insert 'IS 14697 : 1999 ac static transformer operated watt-hour meters and var hour meters, Class 0.2S, 0.5S and 1.0S.' at the end.

(Page 21, Annex D, title) — Substitute 'TEST CIRCUIT DIAGRAM FOR dc AND EVEN HARMONICS' for 'TEST CIRCUIT DIAGRAM FOR DC EVEN HARMONICS AND SUB-HARMONICS'

(Page 21, Annex D) — Insert the following above the existing figure:

'D-1 CIRCUIT FOR HALF WAVE RECTIFICATION'

(Page 21, Annex D, clause D-1) — Insert the following new clauses at the end:

D-2 HALF-WAVE RECTIFIED WAVEFORM

DC and even harmonic test

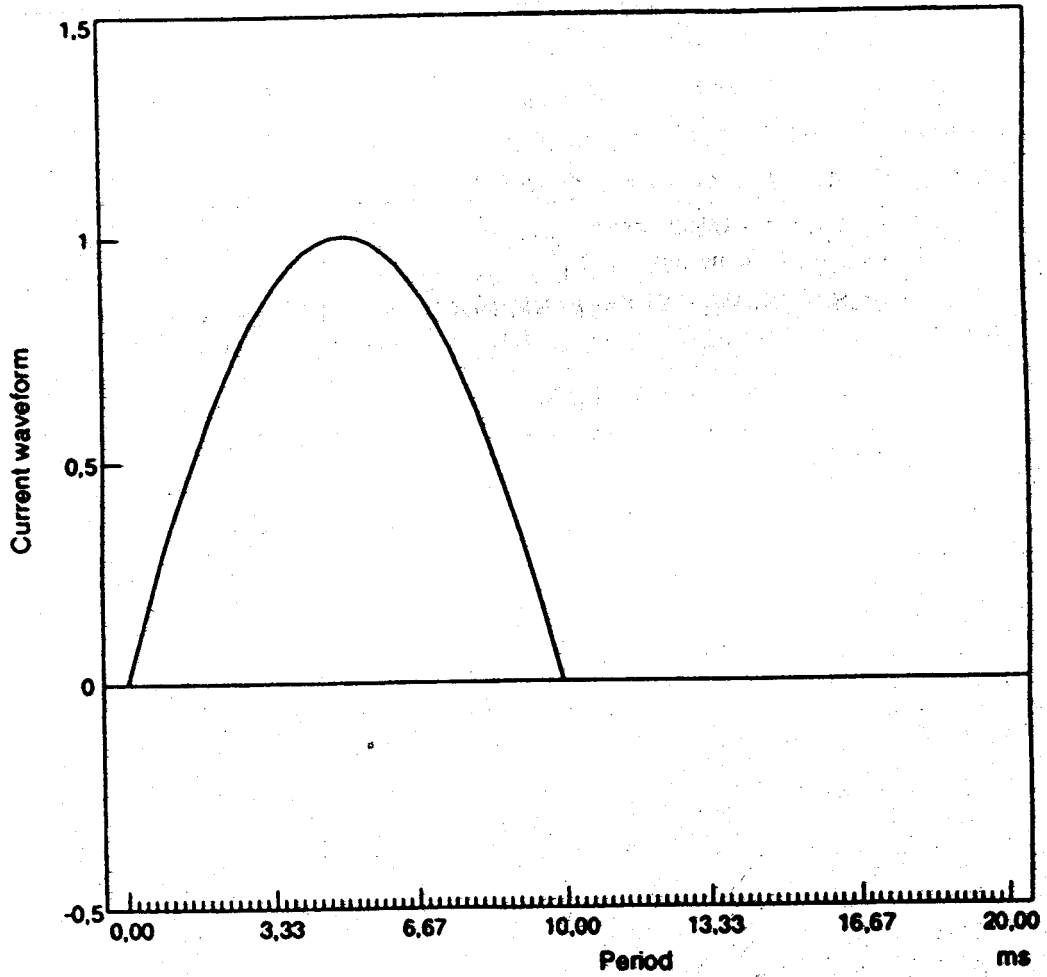

D-3 HALF-WAVE HARMONIC CURRENT

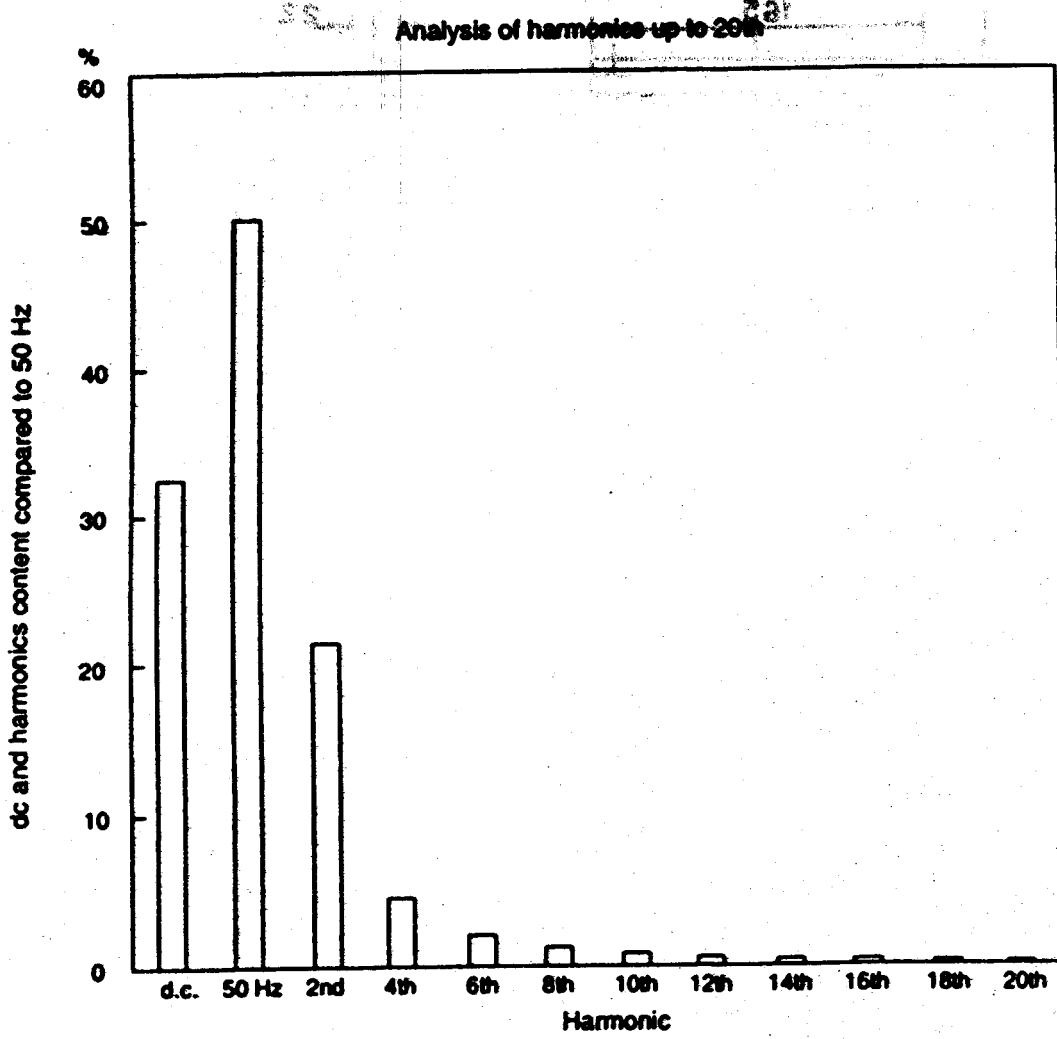

(Page 24, Annex G, figure) — Substitute the following for the existing:

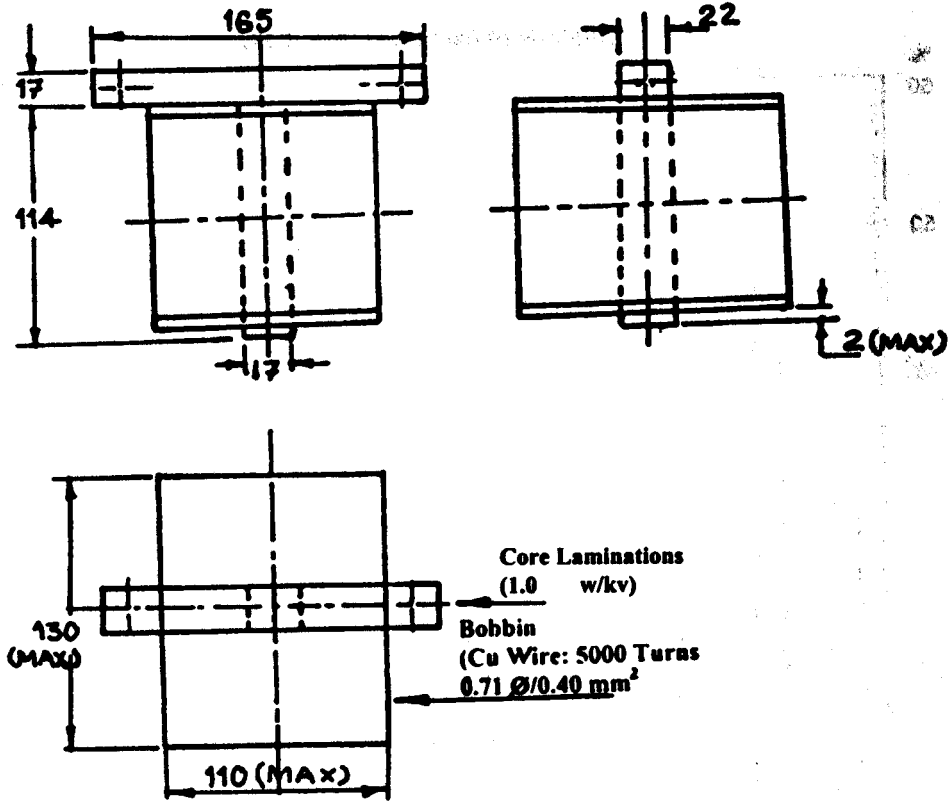

(Page 25, Annex H) — Insert Annex J after Annex H:

ANNEX J
(Clause 7.2)
STANDARD CONNECTION DIAGRAMS

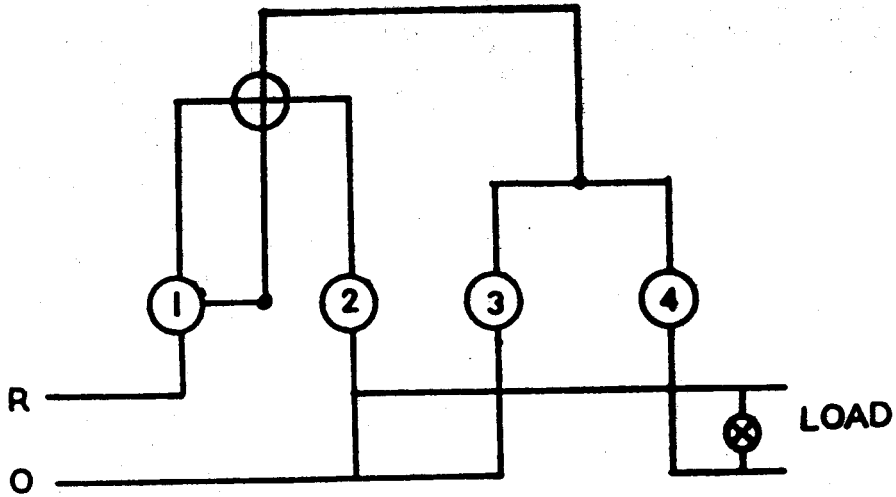

FIG. A

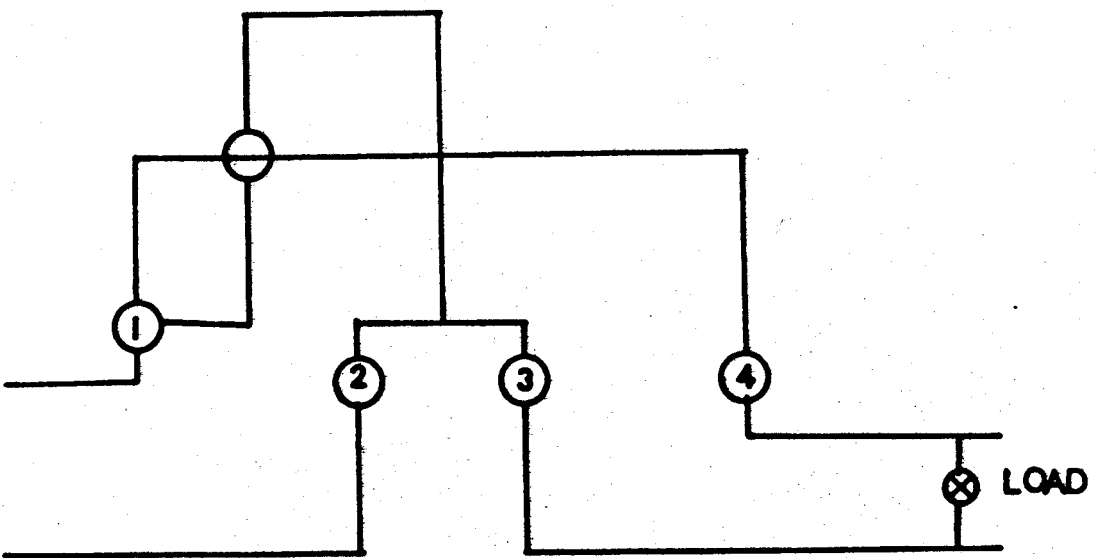

FIG. B

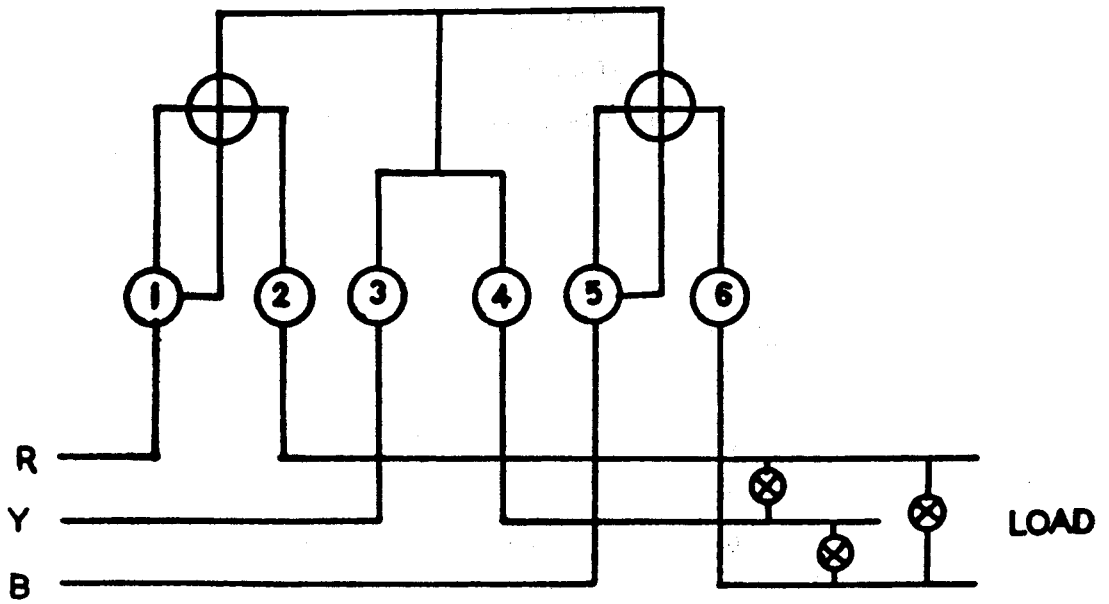

FIG. C

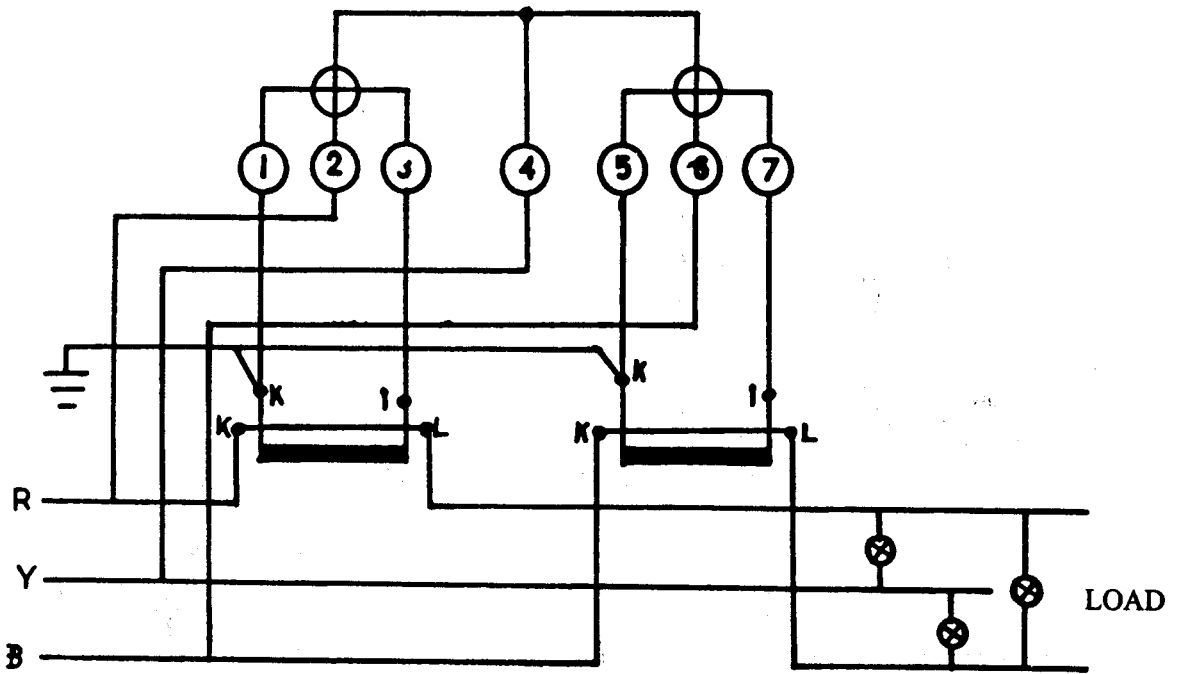

FIG. D

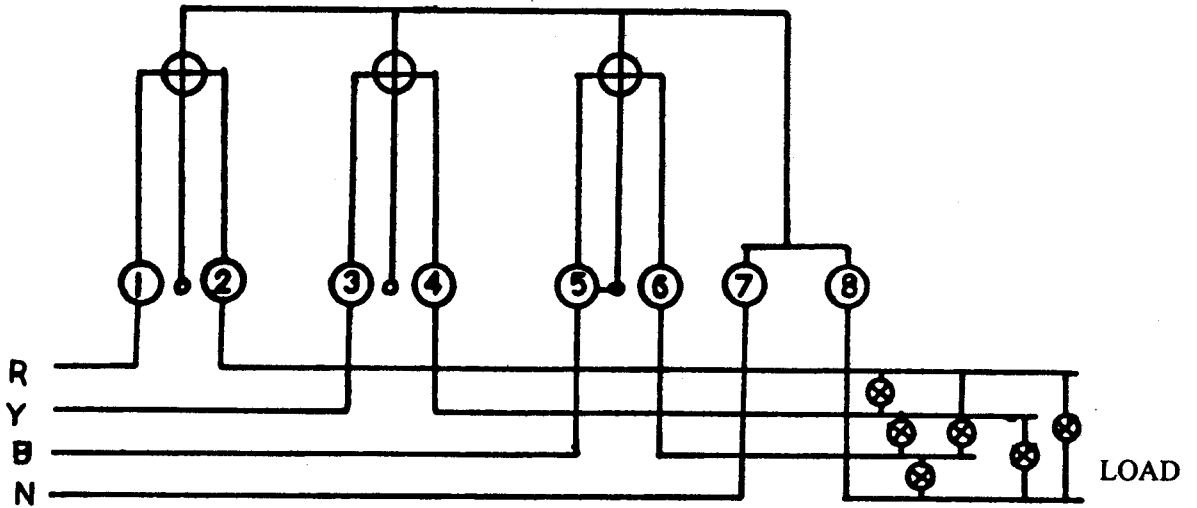

FIG. E

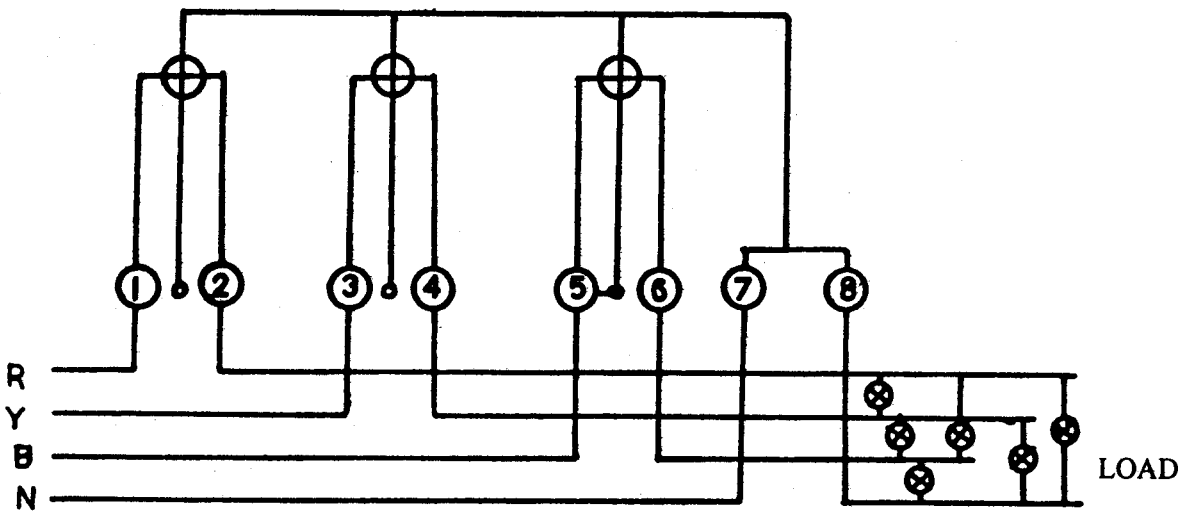

FIG. F

AMENDMENT NO. 2 OCTOBER 2004
TO
IS 13779 : 1999 ac STATIC WATTHOUR METERS,
CLASS 1 AND 2 — SPECIFICATION

(First Revision)

(Page 5, clause 6.2, first sentence) — Substitute the following for the existing:

‘The meter shall have a reasonably dust/moisture-proof case, which shall be sealed by the manufacturer in such a way that the internal parts of the meter are accessible only after breaking such distinctive seal(s)’.

(ET 13)

Reprography Unit, BIS, New Delhi, India

AMENDMENT NO. 3 DECEMBER 2004
TO
IS 13779 : 1999 ac STATIC WATTHOUR METERS, CLASS 1 AND 2 —
SPECIFICATION

[Page 1, clause 1.3(c)] — Delete and renumber 'd' as 'c'.

(Page 4, clause 5.3) — Substitute the following for the existing:

'The maximum current for direct connected meters shall preferably be an integral multiple of the basic current (for example four times the basic current).

When the meter is operated from current transformer(s), attention is drawn to the need to match the current range of the meter in relation to that of the secondary of the current transformer(s). The maximum current of the meter is $1.2I_b$, $1.5I_b$ or $2I_b$.

Typical values of rated maximum current as a percentage of the basic current are shown in Table 3.'

(Page 5, Table 3) — Substitute the following table for the existing:

Table 3 Typical Rated Maximum Current
(Clause 5.3)

Meters (1-Phase & 3-Phase) for	Rated Maximum Current as Percentage of Basic Current
Direct connection	200, 300, 400, 500, 600, 800, 1 000
Connection through current transformer(s)	120, 150, 200

(Page 5, clause 6.4, para 2, first sentence) — Delete.

[Page 7, Table 5, col 3, row 3 (see also Amendment No. 1)] — Substitute the following for the existing:

$'3 \times 100/\sqrt{3}$ or 3×63.5 or 3×240 V'.

(Page 8, clause 7.2, Title) — Substitute 'Connections, Diagrams and Terminal Marking' for the existing.

(Page 8, clause 7.2) — Add new para as follows:

'When a number of meters are connected to a single distributing mains for registering electricity supplied to different consumer loads, separate service lines-phase(s) and neutral, shall be used for each meter. Moreover, interconnection of phases or neutrals of such loads connected to different meters must be avoided. Each independently metered consumer load must be directly connected to distributing mains through its meter connected in specified phase sequence so as to meet accuracy requirements of this standard.

Standard diagrams of connection are given in Annex J.'

(Page 10, clause 11.2, Title) — Substitute the following for the existing:

'Limits of Error due to Other Influence Quantities'

(Page 11, Table 17, Sl No. 4) — Delete 'see Note 3'.

(Page 11, Table 17, Note 3) — Delete and renumber the subsequent notes.

(Page 11, Table 17 (see also Amendment No. 1)] — Add the following after Serial number (xi):

xii)	'Abnormal' ac magnetic induction of external origin (10 mT) (see Note 10)	I_b	1	4.0	4.0
------	---	-------	---	-----	-----

[Page 11, Table 17, Note 10 (see also Amendment No. 1)] — Substitute the following for the existing:

'10 The test conditions are specified in clause 12.11. In the event of logging of abnormal magnetic induction with date and time, the positive variation may be beyond the limit of 4 percent, but not exceeding a power value equivalent to the product of rated voltage and maximum current.'

(Page 12, Table 20, col 3, row 6) — Substitute '11.1' for '11.11'.

(Page 15, clause 12.7.6.2, line 1) — Substitute '6 kV' for '5 kV'.

Price Group 2

(Page 18, clause 12.11) — Add the following at the end:

'The abnormal ac magnetic induction of 10 mT (Table 17, Note 10) shall be obtained by placing the meter at various orientation in the centre of a circular coil of square section (O.D. 400 mm, I.D. 320 mm, Depth 45 mm, 2800 AT) produced by a current of the same frequency as that of the voltage applied to the meter and under the most unfavourable conditions of phase and direction.'

(Page 6, Amendment No. 1) — Substitute 'Core lamination (1 W/kg)' for 'Core lamination (1.0 W/kV)'.

(Pages 7, 8 and 9 of Amendment No. 1, Annex J, Figures A to F) — Substitute the following for the existing:

ANNEX J
(Clause 7.2)

STANDARD CONNECTION DIAGRAMS

The standard connection diagrams are given below. The phase supply terminals are generally marked as 'R', 'Y' and 'B', though other conventions are also acceptable if suitably marked on the terminal block cover. The neutral terminal is marked as 'N' and the phase of a single phase supply is generally marked as 'M'. It should be noted that each individual metered connection for independent load should be given an independent set of phase and neutral connections directly from the supply side.

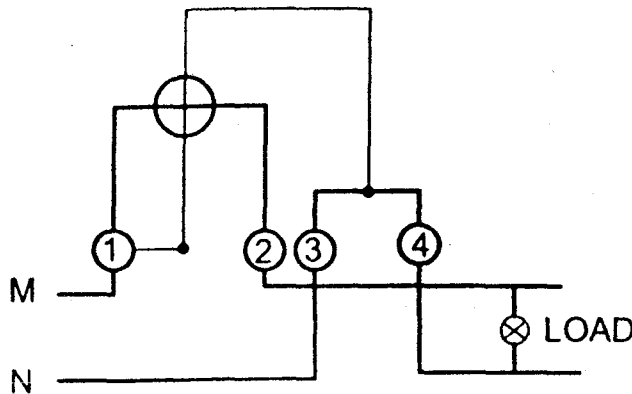

FIG. A SINGLE PHASE TWO WIRE METER

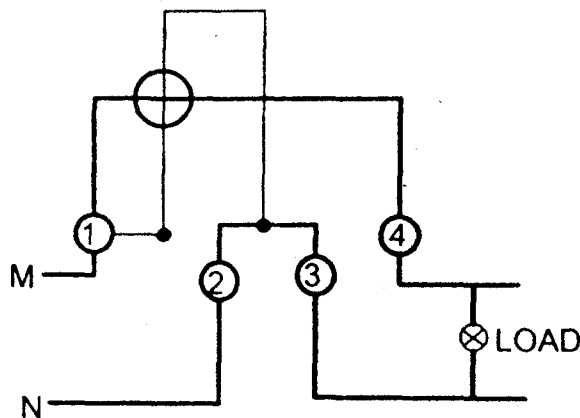

FIG. B SINGLE PHASE TWO WIRE METER SYMMETRICAL CONNECTIONS

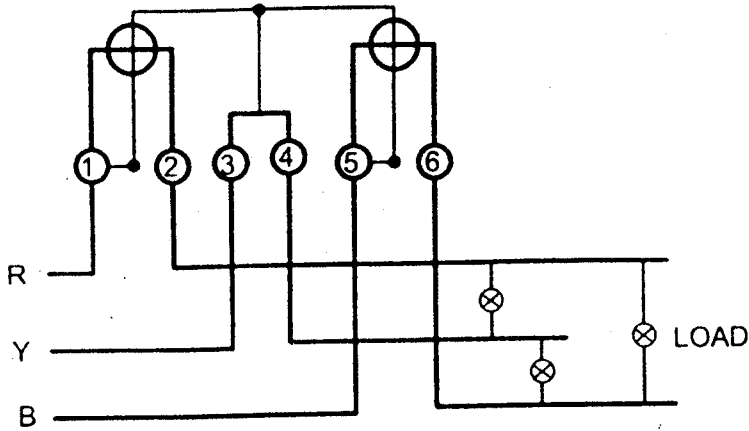

FIG. C THREE PHASE THREE WIRE METER FOR DIRECT CONNECTION

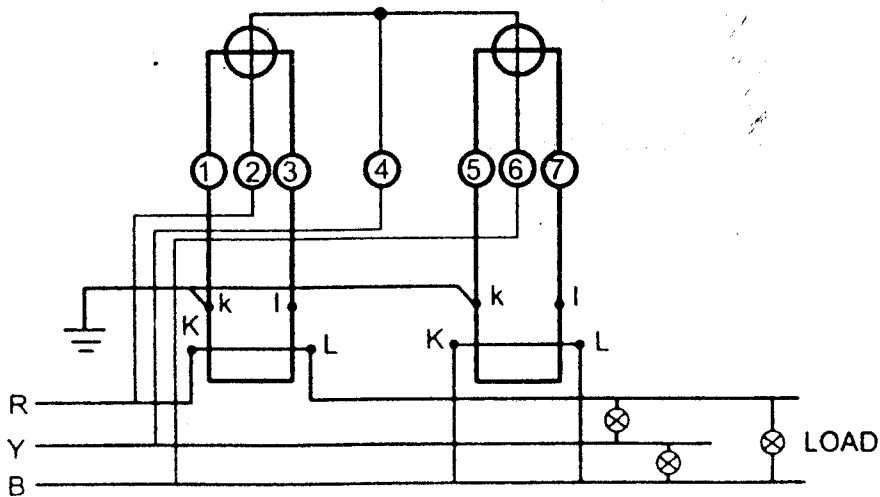

FIG. D THREE PHASE THREE WIRE METER WITH CURRENT TRANSFORMERS

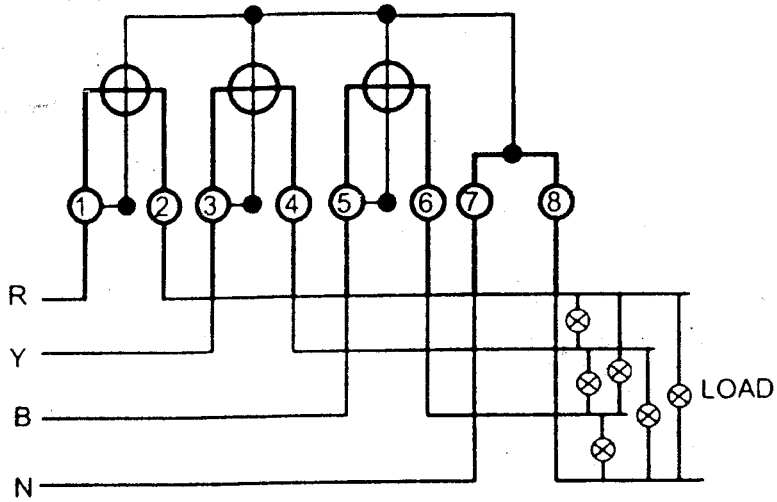

FIG. E THREE PHASE FOUR WIRE SINGLE TARIFF METER FOR DIRECT CONNECTION

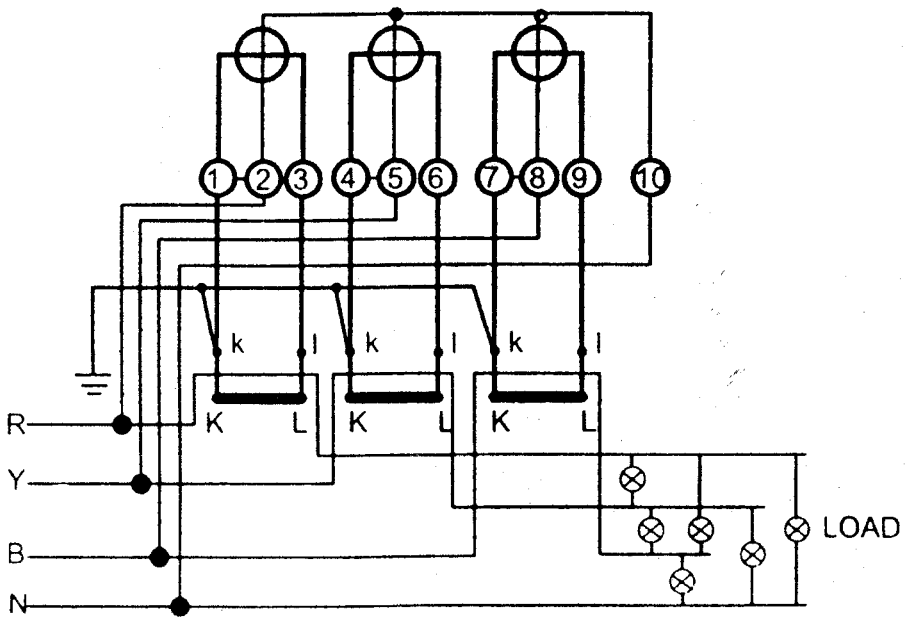

FIG. F THREE PHASE FOUR WIRE METER WITH CURRENT TRANSFORMERS

AMENDMENT NO. 4 JUNE 2006
TO
IS 13779 : 1999 ac STATIC WATTHOUR METERS,
CLASS 1 AND 2 — SPECIFICATION

(First Revision)

(*Page 7, clause 7.1, first sentence*) — Substitute the following for the existing:

‘Every meter shall bear the following information:’

[*Page 7, clause 7.1(a)*] — Substitute the following for the existing:

‘Manufacturer’s name and/or trade-mark and place of manufacture.’

[*Page 7, clause 7.1(n)*] — Insert the following new SI No. (p) after (n):

‘p) Country of manufacture.’

(*Page 7, clause 7.1, last para*)— Substitute the following for the existing:

‘Information under (a), (b), (c) and (p) may be marked on an external plate permanently attached to the meter cover.’

BHEL, Ramachandrapuram.
Date: 26-07-2009 Time: 09:15:17

(ET 13)