



**TERMS AND CONDITIONS FOR**

**Tender Enquiry No.1415-182 Dated: 27.02.2015 Due Date of Opening:  
13.03.2015**

**Item: Miscellaneous Fastners**

**C1 Inviting Quotations:**

Sealed Bid submission in two part Part-I: Techno-commercial bid and Part-II: Price bid are hereby invited for manufacturing and supply of fasteners & Other Items as per BHEL Drawings, Matl Standards (as per latest revision applicable), TDCs and other technical documents referred in these documents. The relevant documents are attached with the Enquiry.

**Note : For manufacturers-**

Procurement shall be preferred from manufacturers. In case manufacturer insists on engaging a dealer/ agent, such dealer/agent is not allowed to represent more than one manufacturer.

**For dealers-**

In case of dealers/agents, Authorized dealer certificate is required from original manufacturer for this tender. In case bids are received from dealer/agent and manufacturer both, bid submitted by dealer will be rejected. A dealer representing more than one manufacturer will be rejected, kindly quote for single make only.

The two bids should be submitted in separate sealed inner envelopes duly mentioning the detail as follows:

Bid	Description	Superscription on envelope	Min documents to be submitted
<b>Part-I</b>			
	Techno-Commercial bid in response to Tender Enquiry no. 1415-182 Dated 27.02.2015	PART-I: "Techno-Commercial Bid" Tender Enquiry no. 1415-182 Dated 27.02.2015 Due Date of Opening: 13.03.2015 Sender :	1. Acceptance of all terms and conditions. 2. Un-priced (Prices not filled) format showing taxes and duties structure.
<b>Part-II</b>			
	Price Bid in response to Tender Enquiry No. 1415-182 Dated 27.02.2015	PART-II: "Price Bid" Tender Enquiry no. 1415-182 Dated 27.02.2015 Sender:	Price bid duly filled prices in words & figures.

All the sealed envelopes should be put in an outer envelope clearly mentioning Tender Enquiry No.1415-182 Dated 27.02.2015.item description as Miscellaneous Fastners and due date of opening as 13.03.2015 time 1530hrs on it.

**Part-I: Techno-Commercial bid should contain**

- a) Acceptance of Techno-Commercial terms and conditions should be attached next. This can be attached either by signing each page of terms and conditions or a confirmation statement.  
If nothing is mentioned for any term, it shall be summarily concluded that the same is acceptable and no representation whatsoever shall be entertained later on.
- b) Un-priced bid as per format attached. **All details, i.e. whether quoted for item, duties and taxes etc. should be filled.** Price Bid format without the price shall be provided with Part I.
- c) Any deviation proposed by bidder shall be considered by BHEL at its own discretion; and if finally considered, shall carry loading factor at the discretion of BHEL.

Quotations shall reach us by 1500 Hrs and Part-I shall be opened at 1530 Hrs on due date Late offers are liable to be rejected, so please ensure to send the quotation well within due date. Based on evaluation of techno-commercial offers, Price bids of bidders who qualify from techno-commercial evaluation shall be opened. BHEL may decide to open the Price bid same day at 1630 hrs, if all the vendors have accepted the entire tender terms and conditions. If not opened on the same day, all qualifying bidders shall be notified for date of opening of Price bids.

Note: Some items are reserved for MSE as mentioned in bid annexure. In such cases, 100% procurement shall be done from MSE vendors. In case, no response is received from MSEs ,then procurement will be done from Non- MSE firms at sole discretion of BHEL.

**Part II: Price Bids:**

Authorized Signatory



**TERMS AND CONDITIONS FOR**  
**Tender Enquiry No.1415-182 Dated: 27.02.2015 Due Date of Opening:**  
**13.03.2015**

**Item: Miscellaneous Fastners**

**Price bid in the format attached.** Preferably the price bid envelop should contain ONLY the price bid. Further, if even the same conditions are mentioned in the Part-II, but after scrutiny of Part-I, the bidder has agreed to BHEL terms, the same shall be binding and any such condition found in Part-II shall in no case be discussed.

**No Other format shall be used for submitting the price bid.** Any variation in Unit of Supply other than that mentioned in the Price bid format shall not be accepted.

**Anything other than price mentioned in the price bid shall be considered invalid. If there is some discrepancy in Price Bid rates than the rates quoted in words shall be accepted.**

Duties shall be payable extra against ED Gate Pass valid for CENVAT benefit.

Price quoted shall be firm and not subject to any escalation during the contract execution.

Price should be quoted on FOR Destination Goindwal Sahib basis. If not mentioned, it shall be concluded that the offer is on FOR Destination Goindwal Sahib basis. In case rates are Ex-Works basis, loading of expenses i.e., freight, transit insurance shall be done by BHEL at its discretion to arrive at Landed prices. Comparison shall be done at Landed cost to BHEL.

All amounts shall be indicated both in words as well as figures. Where there is difference between amount quoted in words and figures, amount quoted in words shall prevail.

Tenders should be free from CORRECTION AND ERASURES. Corrections if any must be attached. Sealed Tenders can be dropped in the tender box labeled as 'Tender box for MM contracts'. This tender box is located at the entrance of Admin block BHEL Goindwal. For any clarification you can contact on email id tendermm@bhelivp.in.Fax (01859-222061) / E-Mail (tendermm@bhelivp.in) offers received in time shall be considered only when such offers are complete in all respects.

**C2 Validity of offers:**

Offers shall be valid for 45 Days from due date of opening. In case of extension of due date of opening, the offers validity shall be extended accordingly.

**C3 Scope of supply:**

Material shall be supplied as per the applicable latest Technical Delivery Conditions (TDC)/ Material Standard requirements/BPS/Drawing and other requirement as given in the Purchase Order. National & International material Standards shall have to be arranged by vendors themselves. **Comparison and procurement shall be done for set (wherever mentioned), i.e. fastener along with required number of nuts. For the items where corresponding Bolts/Studs/Screws are listed along with nuts, quotation where bidders have quoted for both shall only be considered. If the item is appearing more than once then the minimum of rate will be considered. Note that some of these items are reserved for MSEs firms only. If in an item none of the MSE firm has quoted then BHEL may decide for procuring it from non-MSE. Further if any document is required it must be submitted within the time stipulated by BHEL.**

**C4 Replacement of Rejection:**

If the material is rejected due to defective workmanship during inspection or at the time of actual use, the rejected material shall be replaced by the supplier. Corresponding quantity shall be treated as unsupplied against respective purchase order till replacement is received at BHEL.

If the material is found defective and rejected during use for which payment has already been released the rejected quantity shall be supplied free of cost by the vendor within a month of intimation of the rejection by BHEL. Bidder has to take rejected material by own without any expenses paid by BHEL.

**C5 Terms of payment:**

**C5.1** Due payment against supplies received shall be due after 30 days of receipt and acceptance of material and shall be paid within next 15 days period. In case of any deviation from standard payment term mentioned, BHEL at it's discretion may load on the item price at "Base rate of SBI (as applicable on the date of bid opening; Techno-commercial bid opening) + 6% shall be considered for loading for the period of relaxation sought by bidders. Documents to be submitted:

1. Commercial invoice (in duplicate).
2. Original VAT invoice valid for claiming input tax credit.
3. Compliance Certificate & Inspection clearance certificate released at the time of Pre-Despatch inspection at vendor's works, if any.
4. It is mandatory to mention proper material codes in the invoices and separate invoices to be raised for different POs.



**TERMS AND CONDITIONS FOR**

**Tender Enquiry No.1415-182 Dated: 27.02.2015 Due Date of Opening:  
13.03.2015**

**Item: Miscellaneous Fastners**

- C5.2 Above documents should include your Registration numbers such as ECC no, PAN no, CST no, TIN/ VAT nos. etc.
- C5.3 BHEL will not be responsible for delays in release of payment on account of discrepancies in documentation, so vendor has to ensure compliance to documentation requirement.
- C5.4 **BHEL releases payment through EFT mode. Vendor can provide the necessary details by obtaining format before release of payment while supplying the material.**
- C6 **Delivery schedule:**  
Supplies shall be affected and completed as per schedule mentioned in the POs. Delivery Schedule will be :- Total Quantity Within Two Months Of Placing PO/LOI. Further, BHEL may release delivery schedule from time to time based upon our requirement. Vendor shall be required to complete the order as per the BHEL schedule requested. For supply of Track Bolt With Nut +/- 10% quantity may vary. BHEL reserves the right to cancel or hold orders.
- C6.1 **All test certificates are required before /with the material at BHEL Goindwal; Otherwise BHEL may or may not receive the material. Test certificates may be send on email as mentioned on Purchase orders in scanned form. In no case material will be accepted at BHEL without test certificates. Test certiffctae can also be uploaded on <http://vis.bheltry.co.in/vis/index.jsp>**
- C7 **Inspection:**  
a. All required tests shall be carried out by vendor at no extra cost. Relevant TCs shall accompany the consignment. BHEL may decide to inspect itself/arrange third party at vendors' works itself as and when necessary with prior intimation to the vendor. No additional charges shall be claimed for such inspections.  
b. Vendor will give inspection call sufficiently in advance considering the delivery period stipulated in the purchase order.  
c. Material Test Certificates (MTC), Inspection reports and Compliance/Guarantee Certificate are to be provided along with the supplies. If the Third party inspection is decided by BHEL, then charges will be paid to TPI but the necessary infrastructure will be provided by Bidder without claiming additional charges. Third party inspection if arranged by BHEL, charges will be borne by BHEL but the necessary infrastructure will be provided by bidder without any extra cost. Latest applicable revisions of standards/procedures to be referred.  
d. Any inspection carried out before supply by bidder/incoming stage at BHEL not withstanding, if any defect/non-conformity is noted during processing, the same shall be attended/replaced by bidder at no extra cost.
- C8 **Guarantee:**  
Bidder shall give a guarantee of 18 months from the date of dispatch or 12 months from use, against manufacturing defects, whichever is earlier. In case of non-acceptance of this term bid will be rejected.
- C9 **Access to Manufacturing Premises:**  
For evaluation & during the period of execution of contract, authorized representatives of BHEL shall be allowed free access to the manufacturing facilities for the purpose of inspection or monitoring the progress of contract. This access will also be extended to representatives of BHEL's customers accompanying the authorized representative/s of BHEL, if our contractual requirements with our customers call for the same.
- C10 **Risk Purchase:**  
BHEL shall be entitled to terminate the contract with any vendor and to purchase elsewhere at the risk and cost of the vendor, either the whole or part thereof which the supplier has failed to deliver within the time stipulated as aforesaid. Vendor shall be liable for the losses, which BHEL may sustain by way of such risk purchase in addition to aforesaid penalty for delayed delivery. Purchases made from any other vendor at its quoted rates shall be made and the difference of rates of defaulter vendor and new vendor shall be deducted from running bills of the vendor who has failed to deliver.
- C11 **Penalty for late delivery:**

Authorized Signatory



**TERMS AND CONDITIONS FOR  
Tender Enquiry No.1415-182 Dated: 27.02.2015 Due Date of Opening:  
13.03.2015**

**Item: Miscellaneous Fastners**

'Time is the essence of the contract'. As such, delivery of goods specified in the Purchase Orders shall be made within the time limit prescribed therein. Penalty for late delivery clause will be applicable for delayed supplies @ 0.5% per week or part thereof subject to a maximum of 10%. If any vendor does not accept LD 1/3 of the supply for each week of delay subject to a maximum of 5%, their offer is likely to be rejected by BHEL and the price bid shall not be opened. Bidders accepting for 10% LD shall not be loaded on account of LD. However bidders who offer any other % LD [between 5% to 10%] shall be loaded @ % deviation from 10% and their accepted % e.g. If a bidder accepts for a max of 7% LD only, their offer would be loaded @ 3% (10 - 7 = 3). Once the delivery period mentioned has expired, BHEL may or may not take the delivery of item & reserves the right to cancel Purchase Order.

**C12 Sub -Contract :**

The purchase order or any part thereof shall not be sub-contracted, assigned or otherwise transferred without previously obtaining the BHEL's consent in writing.

**C13 MSE Certification:**

If the bidder is registered as any of Micro/Small enterprise as defined in Micro Small and Medium Enterprises Development Act, 2006; a copy of registration certificate to be attached.

**C14 Preferences to MSES:**

MSE suppliers can avail the intended benefits only if they submit along with the offer, attested copies of either EM II (Acknowledgement of Entrepreneur Memorandum Part II) certificate having deemed validity (five years from the date of issue of acknowledgement in EM II) or valid NSIC certificate or EM II certificate along with attested copy of a CA certificate (Format enclosed at Annexure -1 where deemed validity of EM II certificate of five years has expired) applicable for the relevant financial year (latest audited). Date to be reckoned for determining the deemed validity will be the date of bid opening (Part 1 in case of two part bid).

Non submission of such documents will lead to consideration of their bid at par with other bidders. No benefit shall be applicable for this enquiry if any deficiency in the above required documents are not submitted before price bid opening.

If the tender is to be submitted through e-procurement portal, then the above required documents are to be uploaded on the portal. Documents should be notarized or attested by a Gazetted officer.

In cases where the MSE status is based on Acknowledgement of Entrepreneur Memorandum Part II (hereinafter referred as EM II Certificate), the validity of such EM II certificate will be **deemed as 5 years** (2 years earlier deemed validity + 3 years present extension as per the gazette notification) from the date of acknowledgement of the EM II certificate, unless it is accompanied by a CA certificate (format as per Annexure-1), which will be required for each bid.

**C15 Force Majeure:**

If at any time during the continuance of the contract, the performance in which or in any part by either party of any obligations under the contract are prevented or delayed by reason of any war, hostilities, acts of public enemy, civil commotion, sabotage, fires, explosions, epidemics, quarantine restrictions, or acts of God (hereinafter referred to "an events") then provided the notice of happening of any such event is given by either party to the other within 21 days of the occurrence thereof, neither party shall by reason of such event be entitled to terminate the contract nor shall either party have any claim for damages against the other in respect of such non-performance and delay in performance and delivery under the contract shall be resumed as soon as practicable after such event has come to an end or ceased to exist. If the performance in whole or part of any obligation under the contract is prevented or delayed by reason of any such event, claims of extension of time shall be granted for periods considered reasonable by BHEL subject to prior notification by the vendor to BHEL of the particulars of the event and supply to BHEL, if required, of any supporting evidence. Any waiver of time in respect of partial instalment shall not be deemed a waiver of time in respect of remaining deliveries.

**C16 Arbitration:**

In the event of any dispute and/or difference arising between the Vendor and BHEL as to interpretation and/or execution of the contract and/or the respective rights and liabilities of the parties, such disputes and/or differences shall be referred to the sole arbitrator nominated by BHEL. The provisions of the Indian Arbitration Act and the rules there under shall apply to such arbitration. The award passed by the arbitrator shall be final and conclusively binding on all the parties.

**C17 Jurisdiction:**



**TERMS AND CONDITIONS FOR**

**Tender Enquiry No.1415-182 Dated: 27.02.2015 Due Date of Opening:  
13.03.2015**

**Item: Miscellaneous Fastners**

The court of the place from where the purchase order is issued shall alone have jurisdiction to decide any dispute arising out of or in connection with the purchase order.

**C18 Banned Firms:**

The offers of the bidders who are on the banned list as also the offer of the bidders, who engage the services of the banned firms, shall be rejected. The list of banned firms is available on BHEL website [www.bhel.com](http://www.bhel.com).

**C19 Clarifications:**

The correspondence exchanged against the tender from both tenderer and BHEL through email are considered as valid document legally though it is not signed.

It is treated as valid confirmations made on behalf of the respective company and very much comes under the legal ambit of the business transaction and hence it is binding on both the parties to the business. Any transaction pertaining to the tender from both the parties of business done round the clock irrespective of the office or business hours of the companies, are valid legally and binding on both the parties. This applies to the extent only in such cases where deadline time for transaction is not specifically declared by either or both the parties to the business.

**C20 Purchase Order:**

BHEL may issue LOI prior to the PO for any reason whatsoever. The LOI in such cases is to be treated as PO for all practical purposes and all the Terms & Conditions of the tender shall be applicable from the date of issue of LOI. Comparison of rates will be done on the basis of landed cost to BHEL for individual item. In case a vendor turns out to be L1 in one item only, than vendor have to commence the Purchase order within specified time period irrespective of the total value of PO.

**C21 Words and Figures:**

a. If, in the price structure quoted for the required goods/ services/ works, there is discrepancy between the unit price and the total price (which is obtained by multiplying the unit price by the quantity), the unit price shall prevail and the total price corrected accordingly, unless in the opinion of the purchaser there is an obvious misplacement of the decimal point in the unit price, in which case the total price as quoted shall govern and the unit price corrected accordingly.

b. If there is an error in a total corresponding to the addition or subtraction of subtotals, the subtotals shall prevail and the total shall be corrected; and

c. If there is a discrepancy between words and figures, the amount in words shall prevail, unless the amount expressed in words is related to an arithmetic error, in which case the amount in figures shall prevail subject of (a) and (b) above.

d. If there is such discrepancy in an offer, the same shall be conveyed to the bidder with target date upto which the bidder has to send his acceptance on the above lines and if the bidder does not agree to the decision of the purchaser, the bid is liable to be ignored.

**C22 Packaging:**

All material has to be dispatched in packing boxes only i.e. wooden or carton or cardboards with material code, description, grade and quantity. Preferable is to supply no of packing boxes with small quantities eg if 500 Bolts are to supplied then it may be supplied in 10 boxes containing 50Pcs. Box must have TAG containing Purchase order No., Material Code, Material Description (as mentioned in PO) along with Unit weight of each item and Total weight of Box and Total Quantity in Box. No cost for these boxes will be given separately and must be included in prices only. Track Bolts must be supplied in standing position so as to facilitate counting.

**C23 General:**

a) BHEL will not be bound by any power of attorney granted by the vendors or by changes in the composition of the firm made subsequent to the execution of the contract.

They may, however, recognize such power of attorney and changes after obtaining proper legal advice, the cost of which will be chargeable to the vendor concerned.

b) BHEL reserves the right to accept or reject any part or whole of the tender by assigning a valid reason thereof. BHEL reserves the right to cancel the tender without assigning any reason thereof and without any obligation before any commitment.

c) BHEL reserves the right to short close the contract at any time. The quantity supplied or requirement intimated by BHEL will stand as it is, but contract may be close for further supplies, if no further requirement exists.

Authorized Signatory



**TERMS AND CONDITIONS FOR  
Tender Enquiry No.1415-182 Dated: 27.02.2015 Due Date of Opening:  
13.03.2015**

**Item: Miscellaneous Fastners**

d) Please submit acceptance of all techno-commercial terms along with quotation. If nothing is mentioned for any term, it shall be concluded that the same is acceptable. Performance of suppliers shall be monitored periodically by user department of BHEL.

Annexure-1

**Certificate by Chartered Accountant on letter head**

This is to Certify that M/S ..... (hereinafter referred to as 'company') having its registered office at ..... is registered under MSMED Act 2006, (Entrepreneur Memorandum No (Part-11) ..... dtd:....., Category:..... (Micro/Small)). (Copy enclosed).

**1. For Manufacturing Enterprises:** Investment in plant and machinery (i.e. original cost excluding land and building and the items specified by the Ministry of Small Scale Industries vide its notification No.S.O.1722(E) dated October 5, 2006 :  
Rs.....Lacs

**2. For Service Enterprises:** Investment in equipment (original cost excluding land and building and furniture, fittings and other items not directly related to the service rendered or as may be notified under the MSMED Act, 2006: Rs.....Lacs

**(Strike off whichever is not applicable)**

The above investment of Rs.....Lacs is within permissible limit of Rs.....Lacs for .....Micro / Small (Strike off which is not applicable) Category under MSMED Act 2006.

Or

The company has been graduated from its original category (Micro/ Small) (Strike off which is not applicable) and the date of graduation of such enterprise from its original category is ..... (dd/mm/yyyy) which is within the period of 3 years from the date of graduation of such enterprise from its original category as notified vide S.O. No. 3322(E) dated 01.11.2013 published in the gazette notification dated 04.11.2013 by Ministry of MSME.

Date:

Name-

Membership number-

(Signature)

Seal of Chartered Accountant

**BHARAT HEAVY ELECTRICALS LTD**

**IVP, GOINDWAL SAHIB**

**PRICE BID ANNEXURE**

Annexure to Enquiry No. 1415-182 Dated 27.02.2015 Due Date of submitting quotations 13.03.2015

**Item Miscellaneous Fastners**

S.No.	Matl Code	Desc	Drawing/ Specifications/ Requirement	Unit	Qty Nos.	Unit price, Rs	
						In Figures	In Numbers
1	412370807500	BOLT-M 8x75 -8.8-IS1364-P1	SPECN IS-1364(P-1)	Nos	200		
2	412371007000	BOLT-M10x70 -8.8-IS1364P1	IS-1364(P-1)	Nos	500		
3	412211608000	BOLT-M16x80 -4.6-IS1363P1	SPECN IS-1363(P-1)	Nos	500		
4	412010406500	CHS HD SCRU M4X65-4.8 IS:1366	IS-1366	Nos	500		
5	412010301000	CHS HD SCRU-M3x10 -4.8-IS1366	SPECN IS-1366	Nos	800		
6	412010391000	CHS HD SCRU-M3x10 -4.8-IS1366-GALV	IS-1366	Nos	2500		
7	412010491000	CHS HD SCRU-M4x10 -4.8-IS1366-GALV	SPECN IS-1366	Nos	2200		
8	412010491600	CHS HD SCRU-M4x16 -4.8-IS1366-GALV	SPECN IS-1366	Nos	4800		
9	412010691200	CHS HD SCRU-M6x12 -4.8-IS1366-GALV	IS-1366	Nos	5000		
10	412051607000	CSK SCRU M16X70-4.8 IS:1365	IS:1365	Nos	800		
11	960017760000	GREASE NIPPLE-M10 -IS4009P2- A	IS:4009-II(A)	Nos	350		
12	964282010000	GRUB SCREW M12X1.75X20 IS-15628-22H	-----	Nos	100		
13	416010400600	HAM DRV SCRU-2.90x6.4 -IS7519-No.4	SPECN IS-7519	Nos	1600		
14	412152018000	HEX BOLT M20X2.5X180 PCL 6.8 GR B STEEL	STEEL	Nos	200		
15	412212420000	HEX HD BOLT M24 X 200-4.6 IS:1363(P-1)	STEEL	Nos	800		
16	412222406500	HEX HD SCRU M24X65-4.6 IS:1363(P-2)	IS:1363(P-2)	Nos	400		
17	412380691000	HEX HD SCRU-M 6x10 -8.8-IS1364P2-GALV	SPECN IS-1364(P-2)	Nos	1900		
18	412220601600	HEX HD SCRU-M 6x16 -4.6-IS1363P2	SPECN IS-1363(P-2)	Nos	500		
19	412380801200	HEX HD SCRU-M 8x12 -8.8-IS1364P2	PRECISION HEX SCREW M8 X 12;SPECN IS-1364 GR-B(P-2).P8.8	Nos	1600		
20	412220802000	HEX HD SCRU-M 8x20 -4.6-IS1363P2	SPECN IS-1363(P-2)	Nos	100		
21	412380802000	HEX HD SCRU-M 8x20 -8.8-IS1364P2	SPECN IS-1364(P-2)	Nos	5000		
22	412221001600	HEX HD SCRU-M10x16 -4.6-IS1363P2	SPECN IS-1363(P-2)	Nos	100		
23	412381002000	HEX HD SCRU-M10x20 -8.8-IS:1364P2	SPECN IS-1364(P-2)	Nos	100		
24	412381002500	HEX HD SCRU-M10x25 -8.8-IS1364P2	SPECN IS-1364(P-2)	Nos	100		
25	412381005000	HEX HD SCRU-M10x50 -8.8-IS1364P2	SPECN IS-1364(P-2)	Nos	150		
26	412381006000	HEX HD SCRU-M10x60 -8.8-IS1364P2	SPECN IS-1364(P-2)	Nos	100		
27	412381096000	HEX HD SCRU-M10x60 -8.8-IS1364P2-GALV	IS-1364(P-2)	Nos	2050		
28	412381203000	HEX HD SCRU-M12x30 -8.8-IS1364P2	SPECN IS-1364(P-2)	Nos	1300		
29	412381203500	HEX HD SCRU-M12x35 -8.8-IS1364P2	SPECN IS-1364(P-2)	Nos	1350		
30	412221602500	HEX HD SCRU-M16x25 -4.6-IS1363-P2	SPECN IS-1363(P-2)	Nos	250		
31	412381603500	HEX HD SCRU-M16x35 -8.8-IS1364P2	HEX HD SCREW M16 X 35-8.8 SPECN IS-1364(P-2).	Nos	900		
32	412221605500	HEX HD SCRU-M16x55 -4.6-IS1363P2	HEX HD SCRU M16X55-4.6 IS:1363(P-2)/LAT	Nos	100		
33	412162005000	HEX HD SCRU-M20x50 -6.8-IS1364P2	IS-1364(P-2)	Nos	2000		
34	412222006000	HEX HD SCRU-M20x60 -4.6-IS1363P2	IS-1363(P-2)	Nos	100		
35	412162405000	HEX HD SCRU-M24x50 -6.8-IS1364P2	SPECN IS-1364(P-2)	Nos	550		
36	210170490000	HEXAGONAL HEAD SCREW	TSB046/05	Nos	1800		
37	412290001200	LIFT EYE BOLT-M12 -CL3-IS4190-400KGS	SPECN IS-4190	Nos	200		
38	413040000600	NUT -M 6 -CL4-IS1363P3	NUT -M 6 -CL4-IS1363P3 DRG: BPS 41304	Nos	200		
39	413040002000	NUT -M20 -CL4-IS1363P3	NUT -M20 -CL4-IS1363P3 DRG: BPS 41304	Nos	200		
40	931665020000	PLUG-M305	4VM30506587/00	Nos	50		
41	417508001000	SELF LOCK NUT-M10 -SPR-GALV	BPS 417508	Nos	1000		
42	417508001200	SELF LOCK NUT-M12 -SPR-GALV	BPS 417508	Nos	2500		
43	417508001600	SELF LOCK NUT-M16 -SPR-GALV	BPS 417508	Nos	1800		
44	417508002000	SELF LOCK NUT-M20 -SPR-GALV	BPS 417508	Nos	1500		
45	412050601200	SLT CSK SCRU-M 6x12 -4.8-IS1365	SPECN IS-1365	Nos	100		
46	412100601600	SLT GRUB SCRU-M 6x16 -22H-IS2388-C	SPECN IS-2388	Nos	430		
47	412100802000	SLT GRUB SCRU-M 8x20 -22H-IS2388-C	SPECN IS-2388	Nos	100		
48	412020692000	SOC HD SCRU-M 6x20 -8.8-IS2269-GALV	SPECN IS-2269	Nos	2800		
49	412020692500	SOC HD SCRU-M 6x25 -8.8-IS2269-GALV	SPECN IS-2269	Nos	800		
50	412020603000	SOC HD SCRU-M 6x30 -8.8-IS2269	SPECN IS-2269	Nos	1600		
51	412022008000	SOC HD SCRU-M20x80 -8.8-IS2269	IS:2269	Nos	100		
52	412350692000	SOC SET SCRU-M 6x20 -45H-IS6094-CAD	SPECN IS-6094	Nos	250		
53	412350692500	SOC SET SCRU-M 6x25 -45H-IS6094-CAD	SPECN IS-6094	Nos	450		
54	417110302000	SPR DWL SLEEVE-3x20 -IS5988-L	SPECN IS-5988	Nos	1300		

Taxes and other conditions will be as mentioned in Unprice Bids.

Authorised signatory with seal



**BHARAT HEAVY ELECTRICALS LTD**

**IVP, GOINDWAL SAHIB**

**UNPRICE BID ANNEXURE**

Annexure to Enquiry No. 1415-182 Dated 27.02.2015 Due Date of submitting quotations 13.03.2015

Item Miscellaneous Fastners

S.No.	Material Code	Material Description	Drawings/Specifications	Unit	Qty Nos.	Quoted Yes/No
1	412370807500	BOLT-M 8x75 -8.8-IS1364-P1	SPECN IS-1364(P-1)	Nos	200	
2	412371007000	BOLT-M10x70 -8.8-IS1364P1	IS-1364(P-1)	Nos	500	
3	412211608000	BOLT-M16x80 -4.6-IS1363P1	SPECN IS-1363(P-1)	Nos	500	
4	412010406500	CHS HD SCRU M4X65-4.8 IS:1366	IS-1366	Nos	500	
5	412010301000	CHS HD SCRU-M3x10 -4.8-IS1366	SPECN IS-1366	Nos	800	
6	412010391000	CHS HD SCRU-M3x10 -4.8-IS1366-GALV	IS-1366	Nos	2500	
7	412010491000	CHS HD SCRU-M4x10 -4.8-IS1366-GALV	SPECN IS-1366	Nos	2200	
8	412010491600	CHS HD SCRU-M4x16 -4.8-IS1366-GALV	SPECN IS-1366	Nos	4800	
9	412010691200	CHS HD SCRU-M6x12 -4.8-IS1366-GALV	IS-1366	Nos	5000	
10	412051607000	CSK SCRU M16X70-4.8 IS:1365	IS:1365	Nos	800	
11	960017760000	GREASE NIPPLE-M10 -IS4009P2- A	IS:4009-II(A)	Nos	350	
12	964282010000	GRUB SCREW M12X1.75X20 IS-15628-22H	-----	Nos	100	
13	416010400600	HAM DRV SCRU-2.90x6.4 -IS7519-No.4	IS-7519	Nos	1600	
14	412152018000	HEX BOLT M20X2.5X180 PCL 6.8 GR B STEEL	STEEL	Nos	200	
15	412212420000	HEX HD BOLT M24 X 200-4.6 IS:1363(P-1)	STEEL	Nos	800	
16	412222406500	HEX HD SCRU M24X65-4.6 IS:1363(P-2)	IS:1363(P-2)	Nos	400	
17	412380691000	HEX HD SCRU-M 6x10 -8.8-IS1364P2-GALV	SPECN IS-1364(P-2)	Nos	1900	
18	412220601600	HEX HD SCRU-M 6x16 -4.6-IS1363P2	SPECN IS-1363(P-2)	Nos	500	
19	412380801200	HEX HD SCRU-M 8x12 -8.8-IS1364P2	PRECISION HEX SCREW M8 X 12;SPECN IS-1364 GR-B(P-2).P8.8	Nos	1600	
20	412220802000	HEX HD SCRU-M 8x20 -4.6-IS1363P2	SPECN IS-1363(P-2)	Nos	100	
21	412380802000	HEX HD SCRU-M 8x20 -8.8-IS1364P2	SPECN IS-1364(P-2)	Nos	5000	
22	412221001600	HEX HD SCRU-M10x16 -4.6-IS1363P2	SPECN IS-1363(P-2)	Nos	100	
23	412381002000	HEX HD SCRU-M10x20 -8.8-IS:1364P2	SPECN IS-1364(P-2)	Nos	100	
24	412381002500	HEX HD SCRU-M10x25 -8.8-IS1364P2	SPECN IS-1364(P-2)	Nos	100	
25	412381005000	HEX HD SCRU-M10x50 -8.8-IS1364P2	SPECN IS-1364(P-2)	Nos	150	
26	412381006000	HEX HD SCRU-M10x60 -8.8-IS1364P2	SPECN IS-1364(P-2)	Nos	100	
27	412381096000	HEX HD SCRU-M10x60 -8.8-IS1364P2-GALV	IS-1364(P-2)	Nos	2050	
28	412381203000	HEX HD SCRU-M12x30 -8.8-IS1364P2	SPECN IS-1364(P-2)	Nos	1300	
29	412381203500	HEX HD SCRU-M12x35 -8.8-IS1364P2	SPECN IS-1364(P-2)	Nos	1350	
30	412221602500	HEX HD SCRU-M16x25 -4.6-IS1363-P2	SPECN IS-1363(P-2)	Nos	250	
31	412381603500	HEX HD SCRU-M16x35 -8.8-IS1364P2	HEX HD SCREW M16 X 35-8.8 SPECN IS-1364(P-2).	Nos	900	
32	412221605500	HEX HD SCRU-M16x55 -4.6-IS1363P2	HEX HD SCRU M16X55-4.6 IS:1363(P-2)/LAT	Nos	100	
33	412162005000	HEX HD SCRU-M20x50 -6.8-IS1364P2	IS-1364(P-2)	Nos	2000	
34	412222006000	HEX HD SCRU-M20x60 -4.6-IS1363P2	IS-1363(P-2)	Nos	100	
35	412162405000	HEX HD SCRU-M24x50 -6.8-IS1364P2	SPECN IS-1364(P-2)	Nos	550	
36	210170490000	HEXAGONAL HEAD SCREW	TSB046/05	Nos	1800	
37	412290001200	LIFT EYE BOLT-M12 -CL3-IS4190-400KGS	SPECN IS-4190	Nos	200	
38	413040000600	NUT -M 6 -CL4-IS1363P3	NUT -M 6 -CL4-IS1363P3 DRG: BPS 41304	Nos	200	
39	413040002000	NUT -M20 -CL4-IS1363P3	NUT -M20 -CL4-IS1363P3 DRG: BPS 41304	Nos	200	
40	931665020000	PLUG-M305	4VM30506587/00	Nos	50	
41	417508001000	SELF LOCK NUT-M10 -SPR-GALV	BPS 417508	Nos	1000	
42	417508001200	SELF LOCK NUT-M12 -SPR-GALV	BPS 417508	Nos	2500	
43	417508001600	SELF LOCK NUT-M16 -SPR-GALV	BPS 417508	Nos	1800	
44	417508002000	SELF LOCK NUT-M20 -SPR-GALV	BPS 417508	Nos	1500	
45	412050601200	SLT CSK SCRU-M 6x12 -4.8-IS1365	SPECN IS-1365	Nos	100	
46	412100601600	SLT GRUB SCRU-M 6x16 -22H-IS2388-C	SPECN IS-2388	Nos	430	
47	412100802000	SLT GRUB SCRU-M 8x20 -22H-IS2388-C	SPECN IS-2388	Nos	100	
48	412020692000	SOC HD SCRU-M 6x20 -8.8-IS2269-GALV	SPECN IS-2269	Nos	2800	
49	412020692500	SOC HD SCRU-M 6x25 -8.8-IS2269-GALV	SPECN IS-2269	Nos	800	
50	412020603000	SOC HD SCRU-M 6x30 -8.8-IS2269	SPECN IS-2269	Nos	1600	
51	412022008000	SOC HD SCRU-M20x80 -8.8-IS2269	IS:2269	Nos	100	
52	412350692000	SOC SET SCRU-M 6x20 -45H-IS6094-CAD	SPECN IS-6094	Nos	250	
53	412350692500	SOC SET SCRU-M 6x25 -45H-IS6094-CAD	SPECN IS-6094	Nos	450	
54	417110302000	SPR DWL SLEEVE-3x20 -IS5988-L	SPECN IS-5988	Nos	1300	

Excise Duty rate (mention in % if applicable, mention as NIL if not applicable)

Pl. clearly mention

Cess on ED rate (mention in % if applicable)

Extra@

Pl. clearly mention

CST (%)

Extra@

Pl. clearly mention

VAT (%)

Extra@

Pl. clearly mention

Validity of offers (As per BHEL terms 45 days validity is required)

Pl. clearly mention

Delivery terms (FOR Goindwal Sahib)

Pl. clearly mention

MSE Firm (YES/NO)

Pl. clearly mention

MSE Documents attached (Yes/No)

Pl. clearly mention

Please note that nothing will be considered other than prices in the price bid.

Authorised signatory with seal



6.3 / 3.2

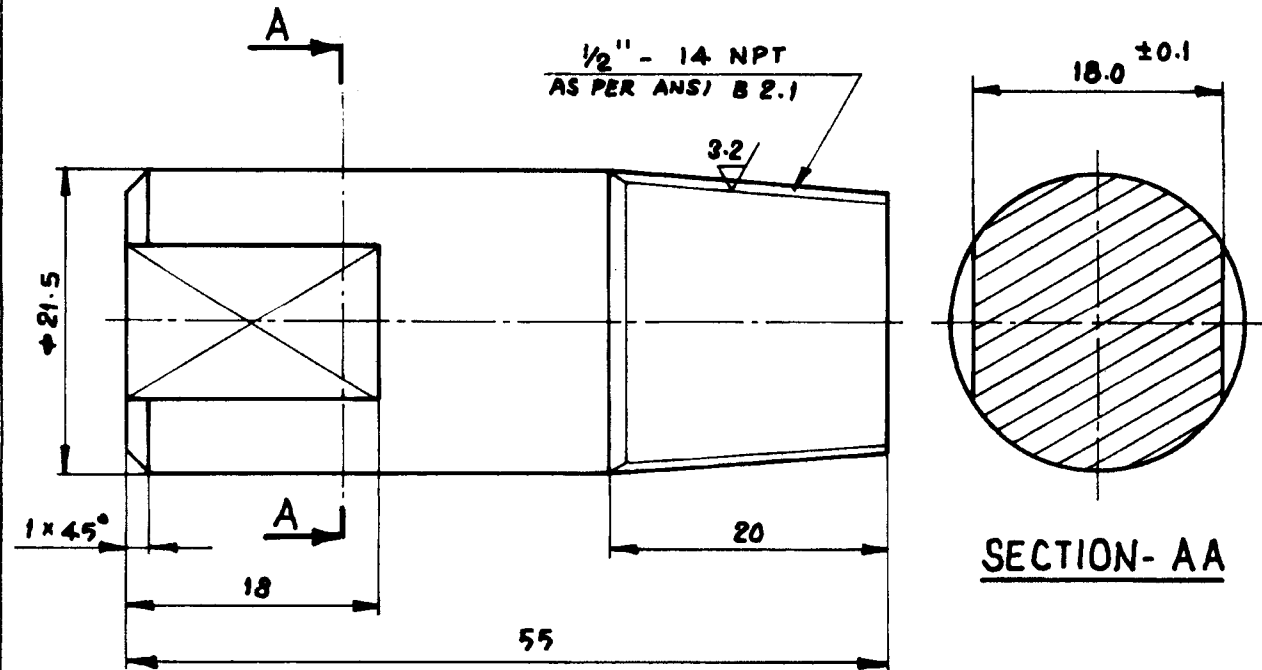

SECTION-AA



01	BAR $\phi$ 22 x 60	15339343	SA 105	NORMALISED	10	0.15	0.18	33116 903 0000
NO. OF PIECES	DESCRIPTION	MATL. CODE	FINAL MATERIAL	HEAT TREATMENT	SCRAP SORT	NET Wt (kg)	GROSS Wt (kg)	COMPONENT CODE DRAWING No.
REMARKS				TOTAL NET Wt (kg)				
SCALE	DRAWN	M. <i>[Signature]</i>	TRANS. COPY NO.	ALTERATIONS	DATE	SIGNATURE	ALTERATION INDEX	
	CHECKED							
	APPROVED	N. NAGARAJAN. <i>[Signature]</i>						
	DATE	14-11-90						
		TYPE	GROUP	OLD DRG.	NEW DRG.			
33-116		TITLE <b>PLUG</b>		DRAWING NO. <b>4-V-M305-06587</b>				

*[Handwritten signature]*



# PLANT STANDARD

HPBP TIRUCHIRAPPALLI

BPS 41304

Rev. No. 02

PAGE 1 OF 2

## HEXAGON NUTS, PRODUCTS GRADES 'B' & 'C'

(Property Class 4 & 14H)

### 1.0 SCOPE

Covers the requirements of hexagon nuts in the size range M27, M33 and above

### 2.0 SPECIFICATION AND REFERENCE STANDARDS

Dimensions and preferred sizes	Fig 1 & Table 1 of this standard	
Tolerance	Product grade	C for nuts with $d \leq M64$ B for nuts with $d > M64$
	Indian Standard	IS 1367 (Part 2) for nuts with $d \leq M39 \times 3$ IS: 3138 for nuts with $d \geq m42 \times 3$
Thread	Pitch	Table 1 of this standard
	Tolerance	7H for nuts with $d \leq M39 \times 3$ 6H for nuts with $d \geq M42 \times 3$
	Indian Standard	IS 4218 (Part 3, 5 & 6)
Material	Steel	
Mechanical properties	Property class	4 for nuts with $d \leq M39 \times 3$ 14H for nuts with $d \geq M42 \times 3$
	Indian standard	IS: 1367 (Part 6&7)
Sampling and Acceptability	Indian Standard	IS: 1367 (Part 17)
General requirements	Nuts shall comply with IS: 1363 part 3 and IS: 3138 in respect of requirements not covered in this standard	

### 2.1 Referred standards (only current versions are applicable)

IS: 1367 (Part 2, 6, 7 & 17)

IS: 3138

IS: 4218 (Part 3, 5 & 6)

Technical supply conditions for threaded steel fasteners

Specification for hexagon bolts and nuts

ISO Metric screw threads

### 3.0 DESIGNATION

A Grade 'C' hexagon nut to this standard of thread size M36x3 shall be designated as :

### 3.1 On Drawings

i) Material Specification column

ii) Description Column

iii) Drawing Number Column

iv) Material Code column:

-----  
HEX NUT GR C M36x3-4

BPS 41304

4130400036

Revisions Brought upto date			Approved STANDARDS SECTION CONTRACT ENGINEERING AND CO-ORDINATION HPBP, TIRUCHIRAPPALLI		
Rev. No. 02	Amd. No.	Reaffirmed	Prepared	Issued	Dt of 1st Issue
Dt. JUN 1997	Dt.	Year	STANDARDS	STANDARDS	DEC 1986

COPYRIGHT AND CONFIDENTIAL  
The information on this document is the property of BHARAT HEAVY ELECTRICALS LIMITED. It must not be used directly or indirectly in any way detrimental to the interest of the company.



# PLANT STANDARD

HPBP TIRUCHIRAPPALLI

BPS 41304

Rev. No 02

PAGE 2 OF 2

## 3.2 Ordering Description

For placing indents, issuing enquires and on purchase order, ordering description given below shall be followed. (Typical examples)

- i) HEXAGON NUT M33 TO BPS:41304 for nuts with  $d=M27$  &  $M33$
- II) HEXAGON NUT M36x3 TO BPS:41304 for nuts with  $d \geq M36X3$

## 4.0 ADDITIONAL INFORMATION

Copies of this standard shall be enclosed alongwith the purchase order for thread sizes M27, M33 and above.

**FIG. 1 DIMENSIONS FOR HEXAGON NUTS**  
(All dimensions are in millimetres)

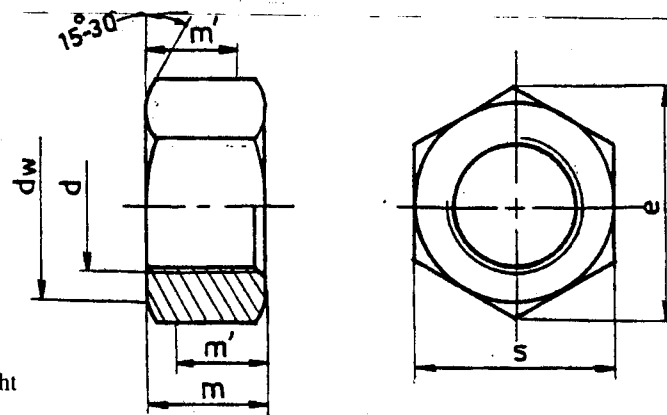

'm' = Effective gauging height

**TABLE 1**  
(All dimensions are in millimetres)

Thread Size d	d <sub>w</sub> Min	m		m' Min	s		e		Weight
		Max	Min		Max	Min	Min	Max	
(M27)		22.65	21.35		41	40.0	45.20		166
(M33)		26.65	25.35		50	49.0	55.37		299
M36x3	51.1	31.5	29.4	23.5	55	53.8	60.79		364
(M39x3)		31.8	30.2		60	58.8	66.44		485
(M45x3)		36.0	35.0		70	68.8		80.8	750
M48x3		38.0	37.0		75	73.8		86.5	935
M56x4		45.0	44.0		85	83.6		98	1355
(M60x4)		48.0	47.0		90	88.6		104	1625
M72x4		58.0	56.8		105	103.6		121	2430
M80x4		64.0	62.8		115	113.6		133	3190

**NOTE:**

1. Sizes in brackets are non-preferred.
2. Weights are given in Kg per 1000 numbers only.



# PLANT STANDARD

HPBP TIRUCHIRAPPALLI

BPS 417508

Rev. No. 03

PAGE 1 OF 2

## SELF LOCKING HEXAGONAL NUT WITH SPRING STEEL STRIP INSERT

### 1.0 SCOPE

This standard covers the requirements of self locking hexagonal nut with spring steel strip insert in the size range M8 to M20.

### 2.0 SPECIFICATION AND REFERENCE STANDARDS

Fig 1 and Table 1 of this standard	
Product Grade	A
Indian Standard	IS 1367 Part-2
Pitch	Coarse
Tolerance	6H
Indian Standard	IS 4218(Part 3,5 & 6)
Steel	
Property class	6
Indian Standard	IS 1367 (Part 6)
Suitable spring steel	
Cadmium plating (Thickness 10-15 microns)	
According to IS 1367 (Part 17)	
Vendor shall design and supply the nut with spring insert in such a way that the spring insert shall prevent unscrewing under screwed and tightened condition.	
Nuts shall comply with relevant parts of IS 1367 in respect of requirements not covered in this standard.	

### 2.1 Referred Standards (Only current versions are applicable)

IS 1367 (Part 2, 6 & 17) Technical supply conditions for threaded steel fasteners.  
IS 4218 (Part 3, 5 & 6) ISO metric screw threads.

### 3.0 DESIGNATION

A Grade A self locking hexagonal nut with spring insert of thread size M10 shall be designated as :

Revisions 03 Brought upto date			Approved STANDARDS SECTION CONTRACT ENGINEERING AND CO-ORDINATION HPBP, TIRUCHIRAPPALLI		
Rev. No. 03	Amd. No.	Reaffirmed	Prepared	Issued	Dt of 1st Issue
Dt. JUNE 1997	Dt.	Year	STANDARDS	STANDARDS	JUNE 1976

COPYRIGHT AND CONFIDENTIAL  
The information on this document is the property of BHARAT HEAVY ELECTRICALS LIMITED. It must not be used directly or indirectly in any way detrimental to the interest of the company.



# PLANT STANDARD

HPBP TIRUCHIRAPPALLI

BPS 417508

Rev. No. 03

PAGE 2 OF 2

### 3.1 On drawings

- |                            |                               |
|----------------------------|-------------------------------|
| i) Material spec column    | -----                         |
| ii) Description column     | <b>SELF LOCKG HEX NUT M10</b> |
| iii) Drawing number column | <b>BPS 417508</b>             |
| iv) Material code column   | <b>417508 0010</b>            |

### 4.0 ORDERING DESCRIPTION

4.1 For placing indents, issuing enquiries and on purchase order, the ordering description given below shall be followed.

**SELF LOCKING HEX. NUT WITH SPRING INSERT M10 to BPS 417508**

### 5.0 ADDITIONAL INFORMATION

5.1 Copies of this standard shall be sent along with the purchase order.

**FIGURE - 1**

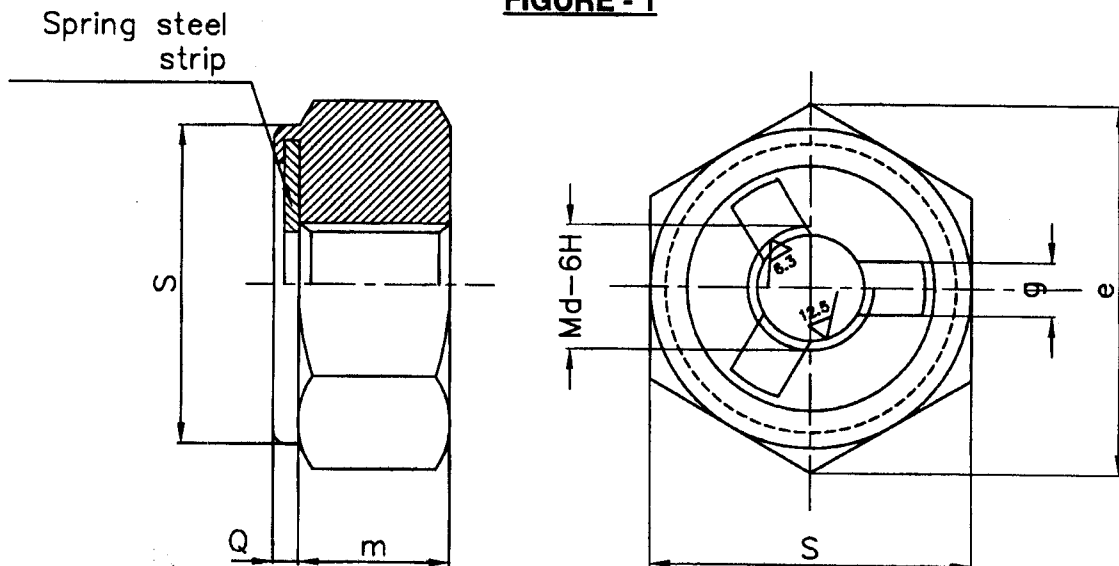

**TABLE - 1**

(All dimensions are in millimetres)

	13.00	17.00	19.00	24.00	30.00
Min	14.38	18.90	21.10	26.75	33.53
Max	--	--	--	--	--
	6.50	8.00	10.00	13.00	16.00
	2.00	2.00	2.00	3.00	3.00
	3.00	3.00	4.00	5.00	6.00
	5.71	13.09	20.00	40.00	75.76

**NOTE :**

1. Weights given in Kg per 1000 numbers.



**PRODUCT ENGINEERING / V & SB  
TECHNICAL DELIVERY CONDITIONS FOR  
SUBDELIVERY COMPONENTS OF SOOT BLOWERS**

TSB : 046

Rev. 05

SHEET No. 01 of 01

**HEXAGONAL HEAD SCREW**

1. Component : Hexagonal Head Screw
2. Material Code : 21 017 049 0000
3. Application : Used in Wall Deslagger for mounting SQ-'D' Limit Switch with limit switch mount.
4. Specification : Hexagonal Head Screw ¼" – 20 UNC, ¾" long  
(OVER ALL) cadmium plated.  
Material : Steel conforming to property class 8.8 according to IS:1367-1967.
5. Inspection : Inspection to be carried out by BHEL Inspectors at BHEL works – For dimensions as per specification above.
6. Quantity : 2 nos. per wall Deslagger.
7. Spares : 5% extra to be added as manufacturing reserve
8. Packing : To be packed and despatched in card board boxes
9. Approximate weight : 0.006 kg/piece

Rev:05 Dt.20/09/2008.

HEX. HEAD SCREW WAS HEX. HEAD CAP SCREW.

Prepared (K.SRIDHARAN)

Date:  
20 / 09 / 2008.

Approved (S. NATARAJAN)