



BHARAT HEAVY ELECTRICALS LIMITED

HEEP HARIDWAR INDIA-PIN 249403

FAX NO: 0091 1334 226462

PHONE NO: 0091 1334 284658

Enq. No.: **T/T206/2014/5150W/3**

Date of issue : 09/04/2015

M/S.....

Sub: BHEL-HEEP/OPEN-TENDER (COMPONENT)/2013

Dear Sir,

The Heavy Electricals Equipment Plant (HEEP) located in Haridwar, India is one of the major manufacturing plants of Bharat Heavy Electricals Ltd. The core business of HEEP includes design and manufacture of large steam and gas turbines, turbo generators and so on.

Sealed tenders with the Tender No. and opening date clearly super scribed on the cover are invited from the manufacturers (registered as well as unregistered) for the supply of the following items:-

Sl. No.	Tender No.	Description of Item	Qty.	Opening Date
1	T/T206/2014/5150W/3	W97372603498 PRESSURE GAUGE 0-250 KG/CM ² JR 100 SPEC: ST48001 REV: 04 SIZE: ST48001.321	28 NOS.	30.04.2015
		W973722603242 PRESSURE GAUGE JR-100, 0-25 KG/CM ² SPEC: ST48001 REV:04 SIZE: ST48001.316	10 NOS.	

The details with required delivery are given in **Annexure-1**.

The tender documents can be downloaded from our web site www.bhel.com or www.bhelhwr.co.in, after downloading the tender documents from web site, while submitting the tender as detailed in "Instruction to Bidders", intending vendors must remit tender fee of Rs. 2,000.00 against each tender in the form of Cash (as permissible under Income Tax Act) / Pay Order / Demand draft.. **If tender fees are not submitted than the offer may be out rightly rejected.** As per notification reference no. NSIC/HO/GP/15(4)/2013-14 dated 07.07.2013 Micro & Small Enterprises (MSEs) is not required to submit tender fees. A certificate issued from competent authority shall be submitted in support of Micro & Small Enterprises (MSEs). BHEL will not be responsible for any type of postal delay / incomplete information from vendor.

The date for opening of tender shall be 30.04.2015. Tenders will be received up to 1.45 P.M. on **30.04.2015** and opened on the same day at 2.00 P.M. in the Tender Room. **Please note that tender received after due date & time (1.45PM on 30.04.2015) will not be REPEAT will not be opened.** BHEL will not be responsible for any type of postal / courier delay.

Specifications & Drawing of the above items are available on our above mentioned website with links provided for all Specifications, Drawings & Annexure (At the end of this document). Other cross referred documents can either be physically collected from BHEL, Haridwar or can be obtained by email akhilkg@bhelhwr.co.in or studu@bhelhwr.co.in against proof of draft of the tender fee in favor of BHEL, Haridwar. This draft is to be submitted along with offer. Amendments/Corrigendum, if any, will be hosted on our web site only. Other terms and conditions will be as per tender documents.

The total quantity may undergo change at the time of ordering.

Please submit your Techno-Commercial offer only for the above requirement subject to our terms and conditions.

BIDS shall be opened at 2 PM on the due date in the presence of authorized representative of the bidders who may like to be present. The authorized representative should bring authority letter from their parent company (Manufacturer) for the specific tender no. attending the bid opening.

KINDLY READ “INSTRUCTIONS TO BIDDERS.” QUOTATION NOT IN ACCORDANCE WITH THE INSTRUCTIONS ARE LIABLE TO BE DISQUALIFIED AND IGNORED.

INSTRUCTIONS TO BIDDERS FOR OPEN TENDER

1.0 DEFINITION

Registered Vendors - Are those who are registered with BHEL, Haridwar for Megawatt rating/ Size/ Weight of tendered components in respective steel grade or machining of such components.

Un-registered Vendors - Are those who are not registered with BHEL, Haridwar for Megawatt rating/ Size/ Weight of tendered components in respective steel grade or machining of such components.

2.0 TECHNICAL QUALIFICATION

- Enclosed format – Annexure-2 to be submitted. It is the mandatory requirement. Offer of Vendors not meeting these requirements may not be considered.

3.0 ESSENTIAL INSTRUCTIONS

1. All un-registered vendors shall be approved by BHEL, if found suitable, on the basis of data furnished by them in Supplier Registration Form (SRF) Foreign Vendors or Indigenous Vendors. Vendor (s) shall not be considered for ordering if not approved by BHEL.
2. BHEL team may visit the vendor (s) works for verification of capability and capacity claimed in tender documents/offer (s).
3. The tenders shall be submitted in three parts as described below on or before the due date. Vendor Registration Form shall be submitted by unregistered vendors only.

- i. Part I (Envelop I) – A. Tender Fee

or

Valid certificate towards exemption of tender fee, applicable for Micro and small Enterprises, as mentioned below:

MSE Suppliers can avail the intended benefits only if they submit along with the offer, attested copies of either EM II certificate having deemed validity (five years from the date of issue of acknowledgement in EM II) or valid NSIC certificate or EM II certificate along with attested copy of a CA certificate (format enclosed where deemed validity of EM II certificate of five years has expired) applicable for the relevant financial year (latest audited). Date to be reckoned for determining the deemed validity will be the date of bid opening (Part I in case of three part bid). Non submission of such documents will lead to disqualification of their offer. Documents should be notarized or attested by a Gazetted Officer.

B. Pre-Qualifying Requirement (PQR) – refer Annexure – 2.

C. Vendor Registration Form (SRF documents to be placed separately in part-I and not to be mixed with other documents).

- ii. Part II (Envelop II) - Techno -Commercial Bid

- iii. Part III (Envelop III) - Price Bid

4. The Quotation should be from the Principal / Original Manufacturer, failing which the quotation is likely to be ignored. However, if OEM / Principal insist on engaging the services of an agent, such agent shall not be allowed to represent more than one manufacturer / supplier in the same tender. Moreover, either the agent could bid on behalf of the manufacturer / supplier or the manufacturer / supplier could bid directly but not both. In case bids are received from both, the manufacturer / supplier and the agent, bid received from the agent shall be ignored. In Case the quotation is submitted through agent, the quotation must accompany original authorization letter from the Principal / Original Manufacturer.
5. The bidders will have to submit ink-signed offer / bid in original directly to BHEL. **Unsigned bids shall be ignored.**

6. The suppliers or their authorized person may be allowed to attend the tender opening, if duly authorized by their principals, through a specific letter for a particular enquiry or for specific price bid opening on that particular day. General authorization letter is not acceptable
7. Any corrections / amendments shall be properly & fully authenticated with signature. No overwriting is acceptable.
8. Compliance of technical/ commercial terms and conditions as per Annexure-3
9. Part-I will be opened on the date and time specified in the tender notice in the presence of those vendors who wish to attend.
10. Part-II bid will be opened of the vendors who successfully qualify the PQR requirements and have submitted tender fees or valid certificate towards exemption of tender fee, applicable for Micro and small Enterprises.
11. Part – III (Price Bids) along with supplementary price bids, if necessary, will be opened at a later date of only those bidders whose techno-commercial bid has been found acceptable.
12. Vendor to quote best possible deliveries in the offer. Offers of those vendors may not be considered if it is not found suitable to BHEL requirement.
13. Currency exchange rate will be applicable on the date of opening of Part-I for evaluation purpose.
14. Depending upon the delivery suitability, BHEL reserves the right to split order on more than one vendor.
15. Evaluation of Bid: - The bid shall be evaluated
 - a. Cost to BHEL basis. (Basic Cost + Insurance + Transportation + Duty)
 - b. The loading, if any, on account of LD penalty, payment terms or any other cost determined at later stage, which shall be communicated to the vendor.
16. Tenders when finalized shall be in the name of the bidder only and change of name during tender evaluation (without certificate from registrar of company) and after submission of the tender is liable to make the offer ineligible for participation.
17. All test certificates / Guarantee certificates to be submitted in TRIPLICATE along with dispatch documents.
18. BHEL reserves the right to open the price bid (part-III) along with the opening of techno-commercial offer (part-II) at its option and in that case vendor will be informed accordingly.
19. BHEL reserves the right to go for reverse auction. Vendors are requested to give their best price. In case of failure of reverse auction the paper bid shall be processed. Bidder should clearly indicate their acceptance for reverse auctioning in Annexure-3. The bids of those vendors who do not agree for reverse auction may not be considered. The Terms & Condition for Reverse Auctioning are given below.
20. Total weight -- /Gross / Net in Kg. & also package size essentially should be indicated if not exact then approximate.
21. BHEL will evaluate the technical bids against essential criteria/requirements. BHEL may seek clarifications, if required, from the qualified bidders only. These clarifications will be communicated to the eligible vendors. The offers of those bidders, who are unable to respond in specified time frame, are likely to be ignored.
22. SETTLEMENT OF DISPUTES
 - Indigenous Vendors: In all cases of dispute the matter shall be referred for arbitration to any arbitrator to be appointed by the Executive Director or any officer who is the administrative head of Bharat Heavy Electricals Ltd., at Haridwar. The venue of arbitration shall invariably be Ranipur Haridwar. The award of the arbitrator shall be final and binding on both the parties. The arbitrator shall have the power to extend, from time to time, the time for making his award with the consent of the parties.
 - Foreign Vendors: In the event of any dispute or difference arising between the parties to this contract regarding execution of same or their respective rights and liabilities there under, the same shall except as otherwise expressly provided therein, be referred to the arbitration of the two arbitrators, one to be appointed by each party; or in the case of the said arbitrators not agreeing then an umpire to be appointed by the two arbitrators in writing before entering on that reference and provisions of the Indian Arbitration Act ,1940 or any statutory notification, or re-enactment therefore and rules framed there under from time to time shall apply to such arbitration . If the two arbitrators do not agree on the appointment of umpire, the nomination of the umpire shall be done by the International Chamber of Commerce, Paris(France).The decision of arbitrators, or in case of their not agreeing, that of the said umpire shall be binding both on seller and purchaser. The venue of the arbitration invariably be New Delhi.
23. JURISDICTION
All question, dispute or differences arising under, out of or in connection with the purchase order shall be subject to the exclusive jurisdiction of Haridwar courts.
24. OVER RIDING CLAUSE
All stipulations made in any correspondence other than those exchanged in regards to

“instruction” in our tender documents / enquiry for submission of your offer, if at all shall be void to the extent they are repugnant to the conditions contained herein above and in the purchase order.

25. FINALITY OF MANAGEMENT DECISION

At all places in the preceding clauses BHEL Management’s decision shall be final.

4.0 GENERAL INSTRUCTIONS

PART-I (Tender fees (or exemption certificate), PQR and SRF in envelope - I) shall comprise of following documents:

- a. Annexure-2 for Pre-qualification requirement. Point wise reply to all the points mentioned in Pre-Qualifying Requirement specified in the tender. Relevant documents as requested in Pre-Qualifying Requirement must be attached.
- b. Vendor Registration Form (SRF)
(Annexure-4 for Foreign Vendors & Annexure-5 for Indigenous Vendors)
The SRF duly filled up will be assessed for manufacturing capability quality systems being followed, organizational soundness and financial worthiness. The same shall be submitted with Part-I by un-registered vendor only with BHEL, HEEL, Haridwar. BHEL registered vendors (registered with permanent code M, N, S) need not to submit SRF.
For vendors registered with T code, SRF is to be submitted essentially along with the offer.
- c. Non-disclosure agreement as per Annexure 6. The agreement shall be duly stamped & signed.

PART-II (Technical clarification in envelope - II) shall comprise of following documents:

- a. Complete technical offer.
- d. Annexure-3 for compliance of technical/ commercial terms and conditions.
- e. Complete technical offer as per specification, drawings, technical requirement along with un-priced bid indicating FOB, C&F rate, separate Lloyd’s/BV/TUV inspection charges (for Foreign vendors) and delivery schedule.
- f. Validity of offer to be indicated.
- g. Deviation with reference to specification/drawing, if any, should be clearly indicated on a separate sheet.
- h. Copy of price Bid (without prices).
- i. Any additional documents.

PART-III (Price Bid)

- a. Price bid with prices to be submitted as part-III of the tender.
- b. If price bid is not submitted along with Part-III bid, the offer will be rejected out rightly.
- c. In case of foreign vendors, prices to be quoted on FOB basis separately. In case of FOB, Loading port must be mentioned. However, for air shipment the rates to be quoted on CPT destination port basis. And air freight charges to be indicated separately in price bid. Further non-availability of flight will not be accepted for rescheduling the delivery or waiver of penalties on account of delayed delivery.
- d. In case of Indigenous vendor, prices must be quoted on FOR-Destination-CPS-HEEL-BHEL basis. However, the insurance will be arranged by BHEL. Vendor can dispatch good through any Indian Bank Association approved transporters having their branch at Haridwar / destination. For the convenience name and address of transporters approved by IBA and BHEL are posted at website www.bhelhwr.co.in. Further, non-availability of BHEL approved transporter will not be accepted for rescheduling of delivery or waiver of penalties.
- e. In case of foreign vendors, third party (Lloyd’s/BV/TUV) inspection charges to be quoted separately as third party inspection (Lloyd’s/BV/TUV) is in vendor’s scope. For Indian vendors, inspection shall be by TUV/ BHEL nominated inspection agency. Prices shall be loaded by 0.18% on account of TUV/ BHEL nominated inspection agency inspection charges. Third Party inspection shall be in BHEL scope.
- f. Prices should remain firm till the execution of the order. However, in case vendor prefers to maintain their own PVC formula, they can do so. Vendors must give upper & lower cap.

However, lower cap has to be either equal or more in percentage point than the upper cap from base prices. This is **must** for evaluation purpose. **Upper price limit** will be considered for evaluation purpose.

- g. Insurance during transportation shall be taken care of by BHEL.
- h. Applicable sales Tax, Excise duty, service tax, educational cess and any other statutory levy should be indicated separately and clearly in the quotation..
- i. **Prices are to be written in both Figures & Words. In case of any difference between the two, If there is a discrepancy between words and figures, the amount in words shall prevail for evaluation and establishing L1 status..**
- j. **LD Penalty shall be applicable at the rate of ½% (half percent) per week or part thereof subject to a maximum of 10% of the value of delayed portion of the order. In case of any variation in LD penalty acceptance, your prices shall be loaded to the extent LD penalty not accepted by you.**
- k. Payment term shall be “100% payment against dispatch documents, through irrevocable LC (for foreign vendors) with bank charges as either side’ and 100% after receipt and acceptance of material (for indigenous vendors)”. **BHEL as a rule do not agree to release advance payment.**
- l. Irrevocable LC is opened for one quarter (3 months) & is established 30 days prior to delivery schedule. The charges of establishing the LC are on either side i.e. charges in India to be borne by BHEL and charges outside of India to be borne by vendor. If any vendor insists for LC for more than one quarter, vendor has to essentially bear all charges (Within & Outside India) for the period exceeding one quarter.
- m. **BHEL does not open confirmed LC even if vendor agrees to bear the confirmation charges.**
- n. **The comparison between foreign and indigenous bids shall be done based on the Total Landed cost at Destination basis.**

Note:

After tender opening (Part-I), if it is found that :

- The bidder has not submitted the requisite Tender Fee.
- The bidder has claimed to be an MSE vendor but no supporting documents have been submitted in this regard.

In both the above cases the offer of the bidder shall be straightaway rejected and no correspondence from the bidder in this regard shall be entertained.

However, offer of the bidder shall be treated as per the guideline in case the bidder has claimed to be an MSE vendor and submitted requisite MSE documents.

BHEL reserves the rights to place order for tendered quantity on more than one vendor

Superscription on envelopes:

The following shall be super scribed on the envelopes:

PART-I

1. TENDER NO. AND ITEMS DESCRIPTION
2. DUE DATE FOR OPENING.
3. TENDER FEE OR MSE CERTIFICATE TOWARDS EXEMPTION OF TENDER FEE
4. PRE- QUALIFYING REQUIREMENT (PQR)
5. SUPPLIER REGISTRATION FORM (SRF)

PART-II

1. TENDER NO. AND ITEMS DESCRIPTION
2. DUE DATE FOR OPENING OF PART-I.
3. TECHNO-COMMERCIAL BID

PART-III

1. TENDER NO. AND ITEMS DESCRIPTION
2. DUE DATE FOR OPENING OF PART-I
3. PRICE BID

The part-I, part-II & part-III shall be individually sealed and super scribed as indicated above and shall be enclosed further in the envelop duly sealed and super scribed as:

“TENDER FOR (ITEM NAME) AGAINST TENDER NO.----- DUE ON -----
-----CONTAINING PART-I, PART-II & PART-III OF THIS OFFER.” Vendor’s full name and address should be clearly mentioned on the envelope and shall be addressed to:

To,
Head of Materials Management,
Heavy Electrical Equipment Plant,
BHEL,
Hardwar- 249403

Envelopes not marked as above are liable to be ignored and will not be opened.

**IN CASE YOU ARE NOT MAKING AN OFFER AGAINST THIS ENQUIRY, THEN PLEASE
ARRANGE TO SEND A LETTER OF REGRET IF YOU HAVE COLLECTED THE TENDER
DOCUMENTS FROM BHEL.**

TERMS AND CONDITIONS OF REVERSE AUCTIONING

Against this enquiry for the subject item /system with detailed scope of supply as per enquiry specifications, BHEL may resort to “REVERSE AUCTION PROCEDURE” i.e., ON LINE BIDDING ON INTERNET.

- For the proposed reverse auction, technically and commercially acceptable bidders only shall be eligible to participate.
- BHEL will engage the services of a service provider who will provide all necessary training and assistance before commencement of on-line bidding on internet.
- BHEL will inform the vendor in writing in case of reverse auction, the details of Service Provider to enable them to contact & get trained.
- Business rules like event date, time, start price, bid decrement, extensions etc. also will be communicated through service provider for compliance.
- Vendors have to fax the Compliance form in the prescribed format (provided by Service provider) before start of Reverse auction. Without this, the vendor will not be eligible to participate in the event.
- BHEL will provide the calculation sheet (e.g., EXCEL sheet) which will help to arrive at “Total Cost to BHEL” like Packing & forwarding charges, Taxes and Duties, Freight charges, Insurance, Service Tax for Services and loading factors (for non-compliance to BHEL standard Commercial terms & conditions) for each of the vendor to enable them to fill-in the price and keep it ready for keying in during the Auction.
- Reverse auction will be conducted on scheduled date & time.
- At the end of Reverse Auction event, the lowest bidder value will be known on the network.
- The lowest bidder has to Fax the duly signed Filled-in prescribed format as provided on case-to-case basis to BHEL through Service provider within 24 hours of Auction without fail.
- Any variation between the on-line bid value and the signed document will be considered as sabotaging the tender process and will invite disqualification of vendor to conduct business with BHEL as per prevailing procedure.
- In case BHEL decides not to go for Reverse Auction procedure for this tender enquiry, the Price bids and price impacts, if any, already submitted and available with BHEL shall be opened as per BHEL’s standard practice.

Annexure- 1

Sl. No.	Tender No.	Description of Item	Delivery required	Qty.
1	T/T206/2014/5150W/3	W97372603498 PRESSURE GAUGE 0-250 KG/CM ² JR 100 SPEC: ST48001 REV: 04 SIZE: ST48001.321	4 NOS.- 30/05/2015 16 NOS.- 15/08/2015 8 NOS. – 15/12/2015	28 nos.
		W973722603242 PRESSURE GAUGE JR-100, 0-25 KG/CM ² SPEC: ST48001 REV:04 SIZE: ST48001.316	10 NOS. – 30/05/2015	10 nos.

- Vendor should quote best delivery.

Annexure 2

Pre- Qualification Requirement

1. Supplier should have minimum two years' experience of design, manufacturing & supply of Flush panel mounted stainless steel pressure gauges with back entry of process connection in any industry. Experience list of unpriced PO copy to be submitted in support of this information.
2. Type test reports for any executed PO shall be submitted for BHEL review as per BHEL – product standard clause no. 5.1 (ii): a) to d) of ST48001.
3. BHEL reserves the right to verify the information submitted by the vendor. In case the information found to be false/ incorrect, the offer shall be rejected.
4. Vendor approval from customer (NTPC & Wanakbori) is required for those vendors who are not approved for the same in BHEL PMD. For approval vendor to furnish vendor data in NTPC sub- contractor questionnaire form for NTPC approval.
5. Vendor approval from customer (Wanakbori) is required for those vendors who are not approved for the same in BHEL PMD. For approval vendor to submit credentials. These data will be submitted to customer for their approval through THC.
6. Inspection by BHEL nominated inspection agency (for indigenous vendor) & third party inspection agency (LRS/TUV/BV) (for foreign vendor) as per BHEL quality plan “QA/BE/QP/913/14-4084 & 14-5150 rev 00”.
7. Ordering (if any) only on BHEL & Customer approved vendors.



SUB-SUPPLIER QUESTIONNAIRE
(To be filled in by the Proposed Sub Supplier)

Name of Equipment / Item / Process with Model/ Type/ Rating / Capacity/ Size/ Tonnage etc. (As applicable):

Trade Name of Product (if any) : _____

1. Name of Proposed Sub-Supplier: _____

Website: _____

2. Address of Regd. Office: _____

Details of contact person:
 Name _____

Mobile no. _____

Desig. _____

E-mail: _____

3. Branch/ Liaison office in Delhi/NCR

Details of contact person:

Name _____

Mobile no. _____

Desig. _____

E-mail: _____

Weekly off day _____

4. Address of Works where
 Item is being manufactured

Details of contact person:

Name _____

Mobile no. _____

Desig. _____

E-mail: _____



SUB-SUPPLIER QUESTIONNAIRE
(To be filled in by the Proposed Sub Supplier)

5. Details of Proposed Works:

- a. Year of Establishment of present works : _____
- b. Year of Commencement of Manufacturing at the above works : _____
- c. Details of change in works address in past, if any : _____
- d. Total Area / Covered Area : _____
- e. Details of covered area like no. of sheds, Area of each shed etc. _____
- f. Electric power- Connected load: _____
Electric power- Stand by load & system: _____

6. Annual Turnover & Profit in past three years : _____

7. Do you have in-house Department for:

- a) Design Yes/No
- b) Research & Development Yes/No
- c) Quality control/Inspection Yes/No
- d) After Sales Service Yes/No

8. Shift works per day One/Two/Three

9. Present Manpower Status:

Division Status	Graduate		Diploma	Skilled	Un-Skilled	Remarks
	Technical	Non-Technical				
Design						
Production						
Quality Control/ Inspection						
After Sales Service						



SUB-SUPPLIER QUESTIONNAIRE
(To be filled in by the Proposed Sub Supplier)

- a. Organization chart of the proposed works is enclosed as Annexure: _____
- b. Organization chart of QA / QC Deptt. is enclosed as Annexure: _____
- c. List of Qualified Welders with process etc. is enclosed as Annexure: _____
- d. List of Qualified NDT personnel with area of specialization is enclosed as Annexure: _____

10. Brief details of items manufactured:

Sl. No.	Item & Material (Type/Size/Rating/Model/ Capacity /Tonnage , as applicable)	Installed Capacity	Annual Production Capacity	Annual Production for last Three years		
				I	II	III

11. Details of foreign Collaboration, if any:

SL No.	Product	Name & Address of Collaborator	Collaboration		
			Scope	Year	Valid upto

12. Type Test report for the proposed product (similar or higher rating)if applicable is enclosed as Annexure: _____
13. Approval / Certification by National / International standards / Accredited agency for the proposed product (if applicable) is enclosed as Annexure: _____
14. Statutory / mandatory certification for the proposed product (if applicable) is enclosed as Annexure: _____
15. Supply Experience list of the proposed product (similar or higher rating) is enclosed as Annexure: _____

[List shall include Item description, (Type/Size/Rating/Model/Capacity/Tonnage, as applicable), Customer name, Quantity, Year of Supply and Year of commissioning]



SUB-SUPPLIER QUESTIONNAIRE
(To be filled in by the Proposed Sub Supplier)

16. End User's operational feedback certificate for the proposed product is enclosed as Annexure: _____
17. List of equipment & machinery specific to the proposed product is enclosed as Annexure: _____
(List shall include name of equipment, capacity & nos. etc.)
18. Process Flow Diagram indicating in-house & outsourced process enclosed as Annexure: _____
19. General manufacturing facilities available in-house:

Sl. No.	Description of machine	Type /Capacity / Size / Rating etc as applicable	Number
a)	Material Handling Mobile Crane Fork Lift Over Head Cranes		
b)	Metal Cutting & Bending		
c)	Casting		
d)	Forging		
e)	Fabrication		
f)	Welding		
g)	Machining		
h)	Heat Treatment		
i)	Surface Cleaning Sand Blasting Shot Blasting Pickling		
j)	Painting		
k)	Metal Coating		



SUB-SUPPLIER QUESTIONNAIRE
(To be filled in by the Proposed Sub Supplier)

l)	Packing		
m)	Other, if any		

20.

a. Inspection & Testing Facilities available in-house:

Sl. No.	Description	Capacity & Nos.	Make & year of Mfg.	Calibration Status	Validity period



SUB-SUPPLIER QUESTIONNAIRE
(To be filled in by the Proposed Sub Supplier)

b. List of Testing & Inspection Facilities outsourced, if any with Source of testing and Description enclosed as Annexure: _____

21. Storage of finished goods (covered / open) : _____

22 List of the source / make with location of major raw material, bought out items and out sourced process enclosed as Annexure: _____

23. Quality management:

23.1 General

23.1.1. Work Instruction for different processes available. (Y/N). _____

If yes, enclose list as Annexure _____

23.1.2. Evaluation system for raw material/bought out item's supplier is available. (Y/N) _____

23.1.3. Records generated during inspection maintained & available for review (Y/N) _____

23.1.4 Statistical quality control techniques used (Y/N) _____

23.1.5 ISO certificate for the works available (Y/N). _____ If yes, enclose copy as Annexure _____

23.2 Corrective action

23.2.1 Specifically confirm whether System for identification & disposition of Non Conformity in the process / product is available. (Y/N) _____

23.2.2 Specifically confirm whether System for Customer complains & their satisfactory disposal is available. (Y/N) _____

23.3. Documentation Control

23.3.1 Procedure available for documentation control (Y/N) _____

23.4. Control of Inspection, Measuring & Testing equipments.

23.4.1 Procedure for calibration of testing & measuring instrument available. (Y/N) _____

24. Any Special Information: _____



SUB-SUPPLIER QUESTIONNAIRE
(To be filled in by the Proposed Sub Supplier)

26. I CERTIFY THAT THE INFORMATION SUPPLIED HEREIN (INCLUDING ALL PAGES ATTACHED) IS CORRECT TO THE BEST OF MY KNOWLEDGE.

SEAL _____
M/S. _____
PLACE _____
DATE _____

SIGNATURE _____
NAME _____
DESIGNATION _____
MOBILE NO _____
EMAIL _____

LIST OF ENCLOSURE:

Certification by Main Supplier: Above information have been verified and found in order / minor changes which have been marked and initialed on this form itself / observed the following discrepancies.

Name : _____ Designation : _____ Signature : _____ Date : _____

NOTE :

1. **COLUMN SHALL NOT BE LEFT UNFILLED..IN CASE OF NOT APPLICABLE / NOT AVAILABLE, THE SAME SHALL BE INDICATED IN THE PROVIDED SPACE.**
2. **IN CASE PROVIDED SPACE IS NOT ADEQUATE, INFORMATION SHALL BE PROVIDED AS AN ATTACHMENT.**
3. **PRODUCT CATALOGUE FOR THE PROPOSED EQUIPMENT/ITEM/PROCESS,IF AVAILABLE, SHALL BE ENCLOSED**



उत्पाद मानक

HW7310198

ST- 48001

**PRODUCT STANDARD
STEAM TURBINE ENGINEERING**

पृष्ठ 1 का 7

Page 1 of 7

**PRESSURE GAUGE WITH S.S. BOURDON TUBE
AND SAFETY BLOW OUT DEVICE**

0.0 SCOPE:

This specification covers the requirements of stainless steel bourdon tube type pressure gauges with bottom and back connections suitable for steam / water and oil service mediums in power plant applications.

1.0 DESIGNATION

- (A) A pressure gauge of Form AR (direct mounting, bottom connection) thread size G ½", dial size 100 mm and range 0-10 kg/cm², size no.114 (Ref Table 1 & 2) shall be designated as :

1.1 ON DRAWINGS :

- Drg. Col : ST-48001.114
- Description Col : PRESSURE GAUGE AR100, 0-10 kg/cm².
- Material specn. : ST 448001

1.2 FOR PLACING PURCHASE INDENTS AND PURCHASE ORDERS :

PRESSURE GAUGE AR100, 0-10 kg/cm², ST48001.114.

- (B) A pressure gauge Form JR (panel mounting, back connection) thread size G ½", dial size 100 and range 0-10 kg/cm², size no.314 (Ref Table 1&2) shall be designated as :

1.3 ON DRAWINGS :

- Drg. Col : ST48001.314
- Description Col : Pressure gauge JR100, 0-10 kg/cm²

1.4 FOR PLACING PURCHASE INDENTS AND PURCHASE ORDERS:

Pressure Gauge JR100, 0-10 kg/cm², ST-48001.314.

- 2.0 Compliance with national / International standard : IS : 3624(1987), IS: 13947(1993) /EN 837-1.

हस्ताक्षर एवं दिनांक SIGN & DATE	नाम NAME	दिनांक एवं हस्ताक्षर SIGN. & DATE
PSC member	अनुवादक TRANSLATED BY	
TSX	निर्माणकर्ता WORKED BY	J.S.BHANDARI
QAX	परीक्षणकर्ता CHECKED BY	VINOD KUMAR
सहमत विभाग AGREED DEPTT.	पर्यवेक्षणकर्ता SUPERVISED BY	B.S. RANA
सामग्री सूची संख्या INVENTORY NO.	स्वीकृति : APPROVED :	ST 3.50
Rev. No.	निर्माण : PREPARED	जारी : ISSUED
Date	CIE	दिनांक : DATE

(Supersedes)

K.B. BATRA

04

Date

27.06.2012

TSX (HEEP) HWR

20.05.1988

COPYRIGHT AND CONFIDENTIAL

The information on this document is the property of Bharat Heavy Electricals Limited. It must not be used directly or indirectly in any way detrimental to the interest of the company.

स्वत्वाधिकार एवं गोपनीय

इस दस्तावेज में दी गई सूचना भारत की इलेक्ट्रिकल भारी मशीनरी एवं उपकरणों के लिए गोपनीय है। इसका उपयोग किसी भी प्रकार में किया जाना नहीं चाहिए।

हस्ताक्षर एवं दिनांक
SIGN & DATEसामग्री सूची संख्या
INVENTORY NO.



उत्पाद मानक

HW 7310198

ST- 48001

PRODUCT STANDARD
STEAM TURBINE ENGINEERING

पृष्ठ 3 का 7

Page 3 of 7

दिनांक एवं हस्ताक्षर
SIGN & DATE

सामग्री सूची संख्या
INVENTORY NO.

स्वत्वाधिकार एवं गोपनीयता
COPYRIGHT AND CONFIDENTIAL

हस्ताक्षर एवं दिनांक
SIGN & DATE

सामग्री सूची संख्या
INVENTORY NO.

3.12 OVER PRESSURE : As per IS : 3624 or EN: 837-1

4.0 IDENTIFICATION TAG :

In addition to the instrument name plate one separate stainless steel blank tag (20 x 60 mm) shall be fastened with the gauge.

5.0 TEST CERTIFICATE :

Three copies of following test certificates shall be furnished .

5.1 The gauge shall be tested for the following tests and degree of protection as per IS :3624 / EN: 837-1 certificates produced.

i) Routine tests : As per IS :3624 or EN: 837-1

- a) Accuracy Test (class IB)
- b) Overload Test

ii) Type Tests :

- a) Endurance Test : As per IS :3624 or EN: 837-1
- b) Enclosure Protection Class : IP65 as per IS :13947(1993)
- c) Temp. Influence Test : As per IS :3624 or EN: 837-1
- d) Shock test : As per IS :3624 or EN: 837-1

5.2 Material certificate for element, movement, shank, case,

6.0 GUARANTEE CERTIFICATE :

A guarantee certificate for trouble free performance for 24 months from the date of shipment or 12 months from the date of commissioning whichever is earlier shall be furnished .

7.0 DOCUMENT :

Two copies of descriptive catalogs indicating sectional , dimensional and mounting details with the help of sketches , full technical particulars including material specification of all components and data against the technical requirement of this specification shall be furnished by the bidder alongwith the offer . Three copies of the same shall be furnished after placement of purchase order .

8.0 PACKING :

Each gauge shall be sealed individually in a bubbled polythene sheet and packed in a thermocole box , the process connection shall additionally be protected by suitable cap. Such boxes in turn shall be packed in a carton or case with adequate cushioning materials in order to be capable of with standing normal transmit risk without damage. If required the package shall be seaworthy.

REV NO.
04

निर्माणकर्ता

J.S BHANDARI

Worked by

जांचकर्ता

V.KUMAR

Checked by

18/6/12

19/6/12

सामग्री सूची संख्या
INVENTORY NO.

R-5106



उत्पाद मानक

HW 7310198

PRODUCT STANDARD
STEAM TURBINE ENGINEERING

ST- 48001

पृष्ठ 5 का 7

Page 5 of 7

दिनांक एवं हस्ताक्षर
SIGN & DATE

SUPERSEDES
INVENTORY NO.

सामग्री सूची संख्या
का अधिकारित क्रमांक है।

COPYRIGHT AND CONFIDENTIAL

The information on this document is the property of Bhandari Heavy Electrical Limited. It must not be used directly or indirectly in any way detrimental to the interest of the company.

स्वत्वाधिकार एवं गोपनीय

एन एचई लि. का यह सूचना-पत्र सभी अधिकारों की सुरक्षा में इस्तेमाल होगा। इसका प्रयोग बिना एन एचई लि. की अनुमति के बिना न करें।

हस्ताक्षर एवं दिनांक
SIGN & DATE

सामग्री सूची संख्या
INVENTORY NO.

TABLE -1

MEASURING RANGE, DIMENSION AND SIZE NUMBER (KG/CM2);

ALL dimensions are in mm.

Measuring Range	Form	AR		JR	
		Dial Size Nom.	100	150	100
Kg/cm2	d1	-	-	5.2	5.8
	PCD d2	-	-	116	178
	OD d3	-	-	134± 2	196±2
Panel Cut Out	-	-	102	165	

Size Number

-1 to 0	101	201	301	401
-1 to 0.6	102	202	302	402
-1 to 1.5	103	203	303	403
-1 to 3	104	204	304	404
-1 to 5	105	205	305	405
-1 to 9	106	206	306	406
-1 to 15	107	207	307	407
0 to 0.6	108	208	308	408
0 to 1	109	209	309	409
0 to 1.6	110	210	310	410
0 to 2.5	111	211	311	411
0 to 4	112	212	312	412
0 to 6	113	213	313	413
0 to 10	114	214	314	414
0 to 16	115	215	315	415
0 to 25	116	216	316	416
0 to 40	117	217	317	417
0 to 60	118	218	318	418
0 to 100	119	219	319	419
0 to 160	120	220	320	420
0 to 250	121	221	321	421
0 to 400	122	222	322	422
0 to 600	123	223	323	423
0 to 1000	124	224	324	424

REV NO.
04

निर्माणकर्ता
Worked by

J.S. BHANDARI

जांचकर्ता
Checked by

V.KUMAR

18/6/12

19/6/12

Handwritten signature and date: P-5106, 18/6/12

Handwritten signature and date: J.S. Bhandari, 18/6/12

Handwritten signature and date: V. Kumar, 19/6/12



उत्पाद मानक

HW 7310198

ST- 48001

PRODUCT STANDARD
STEAM TURBINE ENGINEERING

पृष्ठ 6 का 7

Page 6 of 7

दिनांक एवं हस्ताक्षर
SIGN & DATE

SUPERSEDES
INVENTORY NO.

सामग्री सूची संख्या
की अधिकतम संख्या 1

COPYRIGHT AND CONFIDENTIAL

The information on this document is the property of Bharat Heavy Electricals Limited. It must not be used directly or indirectly in any way detrimental to the interest of the company.

स्वत्वाधिकार एवं गोपनीय

यह दस्तावेज कंपनी की संपत्ति है। इसमें दी गई जानकारी का उपयोग केवल कंपनी के हितों के लिए ही किया जा सकता है। इसका उपयोग अन्य किसी भी उद्देश्य के लिए नहीं किया जा सकता है।

हस्ताक्षर एवं दिनांक
SIGN & DATE

सामग्री सूची संख्या
INVENTORY NO.

TABLE -2

MEASURING RANGE, DIMENSION AND SIZE NUMBER (BAR):

ALL dimensions are in mm.

Measuring Range	Form	AR		JR	
		Dial Size Nom.	100	150	100
Bars	d1	-	-	5.2	5.8
	PCD d2	-	-	116	178
	OD d3	-	-	134±2	196±2
Panel Cut Out		-	-	102	165
Size Number					
-1 to 0		501	601	701	801
-1 to 0.6		502	602	702	802
-1 to 1.5		503	603	703	803
-1 to 3		504	604	704	804
-1 to 5		505	605	705	805
-1 to 9		506	606	706	806
-1 to 15		507	607	707	807
0 to 0.6		508	608	708	808
0 to 1		509	609	709	809
0 to 1.6		510	610	710	810
0 to 2.5		511	611	711	811
0 to 4		512	612	712	812
0 to 6		513	613	713	813
0 to 10		514	614	714	814
0 to 16		515	615	715	815
0 to 25		516	616	716	816
0 to 40		517	617	717	817
0 to 60		518	618	718	818
0 to 100		519	619	719	819
0 to 160		520	620	720	820
0 to 250		521	621	721	821
0 to 400		522	622	722	822
0 to 600		523	623	723	823
0 to 1000		524	624	724	824

REV NO.
04

निर्माणकर्ता Worked by	J.S BHANDARI	<i>J.S Bhandari</i>	12/6/12
जांचकर्ता Checked by	V.KUMAR	<i>V.Kumar</i>	13/6/12

दिनांक एवं हस्ताक्षर
SIGN & DATE



उत्पाद मानक
PRODUCT STANDARD
STEAM TURBINE ENGINEERING

HW 7310198
ST- 48001
पृष्ठ 7 का 7
Page 7 of 7

सामग्री सूची संख्या
को अधिकतम अंकन है ।
SUPERSEDES
INVENTORY NO.

स्वत्वधिकार एवं गोपनीय

COPYRIGHT AND CONFIDENTIAL

The information on this document is the property of Bharat Heavy Electrical Limited. It must not be used directly or indirectly or in any way detrimental to the interest of the company.

इस प्रस्ताव में को सर्व सूचना अनुरोध की इच्छा है।
आपका धन से किसी भी तरह प्रदान, जो कि कंपनी के लिए नुकसानकारी हो न किया जाए ।

हस्ताक्षर एवं दिनांक
SIGN & DATE

सामग्री सूची संख्या
INVENTORY NO.

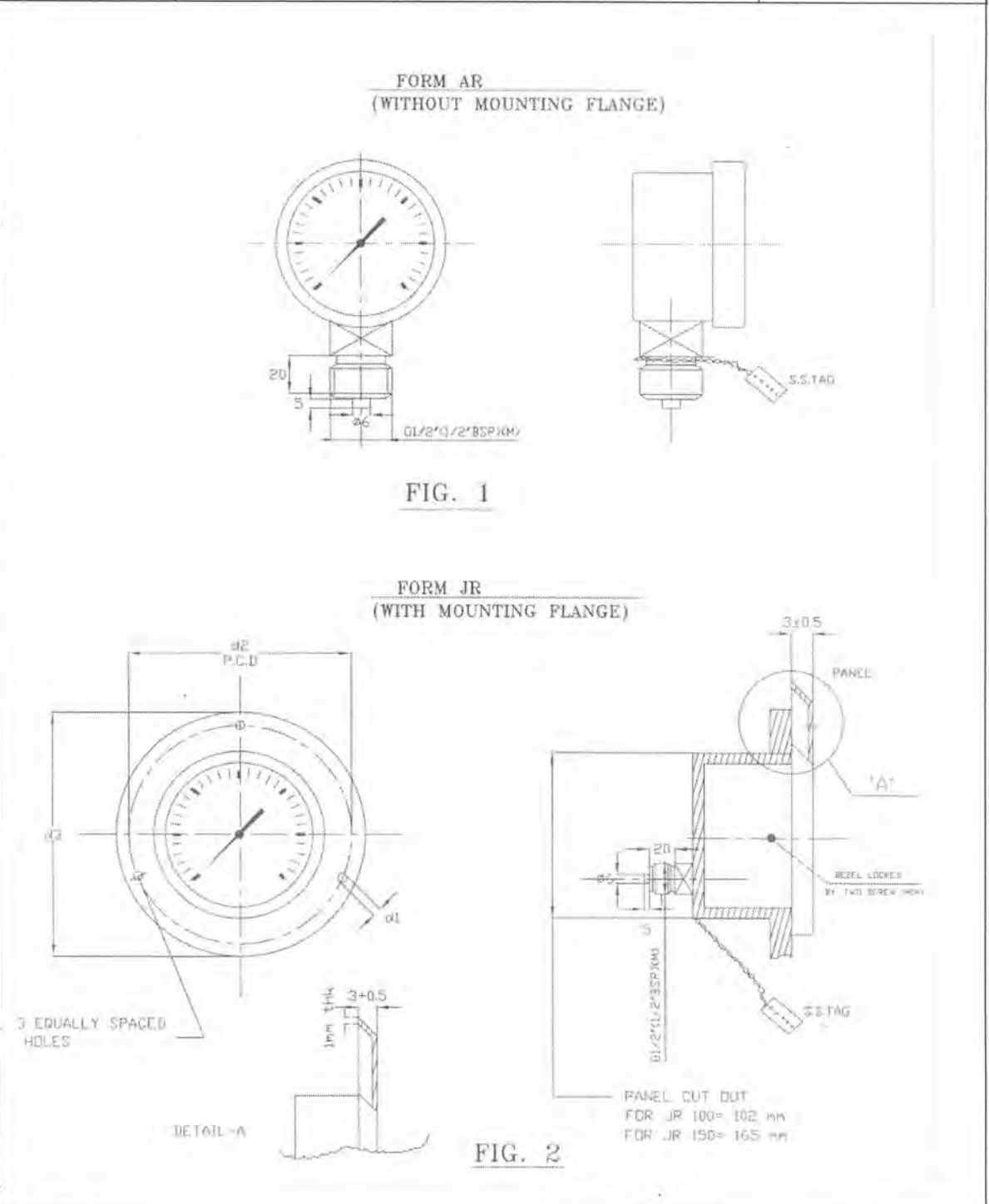

REV NO.	04
---------	----

निर्माणकर्ता	J.S BHANDARI	<i>[Signature]</i>	18/6/12
Worked by	V.KUMAR	<i>[Signature]</i>	19/6/12
जांचकता			
Checked by			

ANNEXURE- 3

COMPLIANCE SHEET FOR TECHNICAL/COMMERCIAL TERMS AND CONDITIONS FOR THREE PART TENDER

PLEASE FILL THIS ANNEXURE & ATTACH WITH YOUR TECHNO-COMMERCIAL BID.

You are requested to kindly confirm /clarify the following:-

S.No.	Description	Your Confirmation
1.	Vendor to confirm that they meet each & every clause of our Specifications/Drawings.	
2.	If “No” to serial number 1, vendor to specify each deviated clause & submit in a separate sheet.	
3.	Vendor to list out on a separate sheet any activity which is outsourced. Please furnish details of out sourced vendor.	
4.	Validity: confirm that validity of the offer shall be 90 days from the date of tender opening	
5.	Confirm that un-priced part of price bid is enclosed with technical commercial offer	
6.	Confirm that prices have been quoted on FOB as well as C & F basis(For Foreign vendors)	
7.	Confirm that Loading Port has been mentioned.	
8.	Confirm that prices have been quoted on FOR BHEL Haridwar basis. (For Indigenous vendor)	
9.	Confirm that prices shall be firm and fixed throughout delivery period.	
10.	Confirm that payment term shall be “100% payment against dispatch Documents through irrevocable LC and bank charges shall be either side” (for foreign vendors) and “100% payment after receipt and acceptance of material” (for indigenous vendors).	
11.	LD Penalty shall be applicable at the rate of ½ % (half percent) per week or part thereof subject to a maximum of 10% of the value of unexecuted portion of the order. In case of any variation in LD penalty, your prices shall be loaded to the extend LD penalty not accepted by you.	
12.	Confirm that all test certificates / Guarantee certificates to be submitted as per BHEL specification. in TRIPLICATE along with dispatch documents	
13.	Right of acceptance – BHEL reserves the right to reject any or all quotations without assigning any reasons thereof. BHEL also reserves the right to increase or decrease the tendered quantities. Vendors should be prepared to accept order for reduced quantities without any extra charges. Vendor should also be prepared for giving discount in case of increase in quantity.	
14.	Confirm specifically that material shall be supplied as per tender documents.	
15.	No grace period in delivery is acceptable. Please quote delivery accordingly.	
16.	Ink signed order acceptance shall be furnished within 15 days of order placement.	
17.	Confirm if there is Indian agency commission included in your price.	
18.	Inspection by third party (Lloyds/BV/TUV) inspection agency as per BHEL approved quality plan “QA/BE/QP/913/14-4084 & 14-5150 rev 00”. Please quote material cost and third party (Lloyds/BV/TUV) inspection charges separately & third party inspection shall be in vendor scope (For Foreign vendors)	
19.	Inspection by BHEL nominated agency as per BHEL approved quality plan “QA/BE/QP/913/14-4084 & 14-5150 rev 00”. Prices shall be loaded by 0.18% on account of third party inspection charges. Third party inspection shall be in BHEL scope (For indigenous vendors)	
20.	Please confirm your acceptance for Reverse Auctioning of these items.	

	ANNEXURE 4	Document No.	AA:MM:SR:01
	GUIDELINES TO FOREIGN SUPPLIERS FOR FILLING UP SUPPLIER REGISTRATION FORM	Revision No.	01
		Page No.	I of II

1. Prospective Suppliers may also visit our web site www.bhel.com (link Supplier Registration -> New Supplier Required) to know more about the requirement of new suppliers for various items in our units.
2. Registration Form no. SRF(F)01 may be obtained from BHEL website www.bhel.com.
3. Application for registration, with a covering letter detailing where your products can find application (if possible) in BHEL unit(s), should be sent to:

Supplier Development Cell
Unit Name:
 Bharat Heavy Electricals Ltd.
City:
 India

4. In case registration is being sought in multiple units of BHEL, please send the separate application to each unit.
5. Any clarification with respect to procedure for registration may be obtained from the Supplier Development Cell of respective BHEL unit.
6. All columns are to be filled up properly in the space provided for. Wherever it is not applicable, mention it as "Not Applicable". The form is to be signed by the authorised signatory and submitted in original.
7. Please attach separate sheet if the space provided is insufficient. For any other information also, separate sheet may be attached.
8. Any information / clarification required by BHEL during processing of registration must be given expeditiously.
9. Please ensure that all required enclosures are attached with the filled up Supplier Registration Form and all enclosures are numbered & list of enclosures is given as required.
10. As multiple copies of the application forms are required for processing at our end, please do not spiral bound the application forms or its enclosures and instead send them in two hole clip flat file.
11. Please fill up the check- list given on next page and send along with the Supplier Registration Forms to BHEL.
12. Please note that if you are registered and participate in Tender process and qualify to get order from BHEL, your performance based on Quality of your product, delivery performance and service rendered will be evaluated inline with Chapter VI.
13. If you are attaching a document in a language other than English, a self attested English translated document may please be also attached.

	ANNEXURE 4	Document No.	AA:MM:SR:01
	CHECK-LIST FOR FOREIGN SUPPLIERS REGISTRATION FORM	Revision No.	01
		Page No.	II of II

S.N.	Check-Point	Yes/No
1.0	Information against all points in the Supplier Registration Form has been given.	
2.0	Authorisation letter has been enclosed (in case of Indian representative)	
3.0	Banker's certificate has been enclosed	
4.0	Are you an ISO: 9001 accredited supplier?	
4.1	If yes, have you enclosed copy of ISO 9001 accreditation certificate & "Table of Contents" of your Quality Manual?	
4.2	If no, have you enclosed written down procedure / manual of Quality Management System?	
5.0	Have you enclosed experience list/ performance certificate (as per sl. 3.0 of the form SRF(F) 01)	
6.0	List of enclosures has been furnished (as per Sl 5.0 of the form SRF(F) 01)	
7.0	All the parts of the form & enclosures have been signed by Authorised Signatory.	
8.0	D&B Report/ Creditreform report etc. has been attached.	

Date :

Signature & seal

(Authorised Signatory)

Note : This check list is to be attached with the filled up Supplier Registration Form.

BHARAT HEAVY ELECTRICALS LIMITED, INDIA

ANNEXURE 4

FORM NO. SRF(F)01 : (FOREIGN SUPPLIER)

Page 2 of 2

- 1.8 YEAR OF COMMENCEMENT OF BUSINESS :
- 1.9 PRODUCTION CAPACITY PER ANNUM (details of major manufacturing/ testing facilities to be given) :
- 1.10 PARTICULARS OF PRODUCTS INCLUDING SPECIFICATION AND RANGE OFFERED FOR REGISTRATION : (ATTACH BROCHURES AND CATALOGUES)
- 1.11 NAME (S) OF BANKERS :
- 1.12 BANKER'S CERTIFICATE AS TO CREDITWORTHINESS OF THE CLIENT (Enclose Certificate) :
- 1.13 PORT OF LOADING :
- 1.14 NEAREST AIRPORT :
- 1.15 Report from D&B/ Creditreform etc. (As per Cl. 7.1 of Chapter V) (MANDATORY):

2.0 FINANCIAL INFORMATION : (FOR LAST 3 YEARS)

PARAMETER	YEAR -1	YEAR -2	YEAR -3
ANNUAL TURN OVER			
PROFIT AFTER TAX			

(COPY OF AUDITED ANNUAL ACCOUNTS FOR LAST 3 YEARS TO BE ENCLOSED)

3.0 QUALITY MANAGEMENT SYSTEM :

- 3.1 IS THE COMPANY ISO:9001 CERTIFIED : YES / NO
- 3.1.1 IF YES, ENCLOSE COPY OF CERTIFICATE & TABLE OF CONTENTS OF QUALITY MANUAL.
- 3.1.2 IF NO, ENCLOSE QUALITY MANANGEMENT SYSTEM OR WRITTEN DOWN PROCEDURE

4.0 EXPERIENCE LIST/ PERFORMANCE CERTIFICATE FOR OFFERED / SIMILAR ITEMS :

(ATTACH LIST OF PRESENT CUSTOMERS WITH NAME & ADDRESS FOR OFFERED / SIMILAR TYPE & SIZE OF ITEM / EQUIPMENT FOR WHICH REGISTRATION HAS BEEN SOUGHT AND WITH WHOM YOU HAVE CONTINUOUS BUSINESS SINCE LAST THREE YEARS)

5.0 ANY OTHER INFORMATION :

6.0 LIST OF ENCLOSURES :
(BROCHURES, CATALOGUES, TECHNICAL LITERATURE ETC.)

Signature & Seal

AUTHORISED SIGNATORY

E – Mail

NAME :

TELEPHONE : (Landline):
Mobile :

DESIGNATION :

DATE :

	ANNEXURE - 5	Document No.	AA:MM:SR:01
	GUIDELINES TO INDIAN SUPPLIERS FOR FILLING-UP SUPPLIER REGISTRATION FORM	Revision No.	01
		Page No.	I of II

- Prospective Suppliers may also visit our web site www.bhel.com (link Supplier Registration -> New Supplier Required) to know more about the requirement of new suppliers for various items in our units.
- Registration Form may be obtained from BHEL website www.bhel.com.
- Application for registration, with a covering letter detailing where your products can find application (if possible) in BHEL unit(s), should be sent to:

Supplier Development Cell
Unit Name:
 Bharat Heavy Electricals Ltd.
City:
 India

- In case registration is being sought in multiple units of BHEL, please send the separate application to each unit.
- Any clarification with respect to procedure for registration may be obtained from the Supplier Development Cell of respective BHEL unit.
- The Supplier Registration Form has four parts:

Part A	Organisational Information	Form no. SRF(I)01 – page 1 to 10
Part B	Quality System	Form no. SRF(I)01 - page 11 to 12
Part C	Technical Competence	Form no. SRF(I)01 page 13 (if sent by BHEL)
Part D	Score Sheet (to be filled by BHEL)	Form no. SRF(I)01 page 14 to 17

The set of formats to be filled by different category of suppliers is as follows:

Sl.No	Supplier Category	Formats
1.	Indian Suppliers (manufacturers)	- Organisational Information - Quality System - Technical Competence
2.	Indian Stockist/ Trader/ Distributor/ Dealer/ Authorised Agent/ Channel partner/ Indian Sales office or Subsidiary of registered foreign principal	- Organisational Information SRF(I)01- Part A (page 1 to 10 except Sl. No. 5.1, 5.2, 6.6, 6.7, 7 & 8)

- All columns are to be filled up properly in the space provided for. Wherever it is not applicable, please mention “Not Applicable”. The form is to be signed by the authorised signatory.
- A separate sheet may be attached if the space provided is insufficient or additional information is to be given. Please put proper identification tag on the separately attached sheet.
- Please ensure that all required enclosures are attached with the filled up Supplier Registration Form and all enclosures are numbered & list of enclosures is given as required.
- As multiple copies of the application forms are required for processing at our end, please do not spiral bound the application forms or its enclosures and instead send them in two hole clip flat file.
- Incomplete forms will be rejected.
- Any information / clarification required by BHEL during evaluation must be given expeditiously.
- Please note that if you are registered and participate in Tender process and qualify to get order from BHEL, your performance based on Quality of your product, delivery performance and service rendered will be evaluated inline with Chapter VI.
- Please fill up the check- list given on next page and send along with the Supplier Registration Forms to BHEL.
- If you are attaching a document in a language other than Hindi/ English, a self attested Hindi/ English translated document may please be also attached.

	ANNEXURE - 5	Document No.	AA:MM:SR:01
	Check List for Indian Supplier Registration Form	Revision No.	01
		Page No.	II of II

Sl.No.	Check-Point	Yes/No
1.	Information against all points under "Organizational Information" (Part-A) has been given.	
2.	All enclosures and supporting documents have been enclosed.	
3.	Summary list of enclosures has been furnished as per S.N.10 of Organisational Information form no. SRF (I) 01 & S.N 12 of Quality system form no. SRF (I) 01.	
4.	Are you an ISO 9001 accredited supplier?	
5.	If yes, have you enclosed "Table of Contents" of your Quality Manual and copy of ISO 9001 accreditation certificate?	
6.	Have you filled up Quality System format given in Part B?	
7.	Technical requirements, specifications, drawings, standards have been received from BHEL before filling up Technical Competence, Part C.	
8.	All the parts of the form & enclosures have been signed by Authorised Signatory.	
9.	Have you attached EFT details? (In original, Certified by the bank)	
10.	If you are seeking registration for a MSME company (as per MSME Act of Government of India), have you attached requisite certificate as per Act?	

Date :

Signature & seal

(Authorised Signatory)

Note: This check list is to be attached with the filled up Supplier Registration Form.

**BHARAT HEAVY ELECTRICALS LIMITED
SUPPLIER REGISTRATION FORM**

FORM NO. SRF(I) 01 (INDIAN SUPPLIER)

ANNEXURE - 5

Page 1 of 17

INFORMATION WITH * MARKS IS SCOREABLE.

PART- A : ORGANISATIONAL SOUNDNESS

ALL COLUMNS SHOULD BE PROPERLY FILLED IN THE SPACE PROVIDED FOR, WHEREVER IT IS NOT APPLICABLE, PLEASE WRITE "NOT APPLICABLE". INCOMPLETE OR INCORRECT FORMS MAY NOT BE CONSIDERED. PLEASE ATTACH SEPARATE SHEET, IF SPACE AVAILABLE IS INADEQUATE.

ALL THE PAGES OF THE FORM ARE TO BE SIGNED ALONGWITH SEAL BY THE AUTHORISED SIGNATORY

ORGANISATIONAL INFORMATION			
NAME AND CORRESPONDENCE ADDRESS OF THE SUPPLIER SEEKING REGISTRATION :-			
1.0 PRODUCTS / SYSTEMS / SERVICES FOR WHICH REGISTRATION IS APPLIED FOR :			
SL. NO.	DESCRIPTION	SIZE & RANGE	MFG. STD/ IS / DIN /BS ETC.
SUPPLIER'S AUTHORISED SIGNATORY		BHEL CERTIFIED ASSESSOR	

**BHARAT HEAVY ELECTRICALS LIMITED
SUPPLIER REGISTRATION FORM**

FORM NO. SRF(I) 01 (INDIAN SUPPLIER)

ANNEXURE - 5

Page 2 of 17

ORGANISATIONAL INFORMATION

2.0 GENERAL INFORMATION :

2.1 NAMES OF THE WORKS/DIVISION (Products manufactured at each works to be mentioned :

ADDRESS : E - Mail :

TELEPHONE : Landline
Mobile

FAX :

2.2 NAME OF CHIEF EXECUTIVE /
PROPRIETOR / PARTNER & ADDRESS :

2.3 DETAILS OF AUTHORISED SIGNATORY FOR SEEKING CLARIFICATION :

NAME :

DESIGNATION : E - Mail

:

TELEPHONE : Landline

Mobile

FAX :

SUPPLIER'S AUTHORISED SIGNATORY

BHEL CERTIFIED ASSESSOR

**BHARAT HEAVY ELECTRICALS LIMITED
SUPPLIER REGISTRATION FORM**

FORM NO. SRF(I) 01 (INDIAN SUPPLIER)

ANNEXURE - 5

Page 3 of 17

ORGANISATIONAL INFORMATION

3.0 OWNERSHIP INFORMATION : DOCUMENTS TO BE FURNISHED

3.1 GOVT. OF INDIA UNDERTAKING:

OR

STATE GOVT. UNDERTAKING :

OR

LIMITED COMPANY, :

MEMORANDUM AND
ARTICLES OF ASSOCIATION

OR

PRIVATE COMPANY :

MEMORANDUM AND
ARTICLES OF ASSOCIATION

OR

CO-OPERATIVE SOCIETY, :

SOCIETY RULES AND
BYE LAWS

OR

PARTNERSHIP FIRM, :

PARTNERSHIP DEED

OR

PROPRIETORSHIP, :

PROFESSION TAX REGN.
AND MUNICIPAL REGN.

ANY OTHER (SPECIFY) :

3.2 NATURE OF BUSINESS :

(MANUFACTURING UNIT/
ENGG CONSULTANT/ EPC CONTRACTOR)

(AGENTS/ DISTRIBUTORS/STOCKISTS/DEALERS/
TRADERS/ INDIAN SUBSIDIARY/ CHANNEL PARTNER – attach authorization
certificate of principal)

3.3 YEAR OF ESTABLISHMENT :

* 3.4 YEAR OF COMMENCEMENT OF BUSINESS :

SUPPLIER'S AUTHORISED SIGNATORY

BHEL CERTIFIED ASSESSOR

**BHARAT HEAVY ELECTRICALS LIMITED
SUPPLIER REGISTRATION FORM**

FORM NO. SRF(I) 01 (INDIAN SUPPLIER)

ANNEXURE - 5

Page 4 of 17

ORGANISATIONAL INFORMATION

4.0 REGISTRATION PARTICULARS

(FURNISH DETAILS AND ENCLOSE COPY OF CERTIFICATE FOR THE FOLLOWING)

- 4.1 PERMANENT ACCOUNT NO :
4.2 CENTRAL SALES TAX REGN NUMBER :
4.3 STATE SALES TAX / TIN NUMBER :
4.4 EXCISE DUTY REGN NUMBER :
4.5 EXCISE CONTROL CODE NUMBER :
4.6 SERVICE TAX REGN NUMBER :
4.7 CATEGORY AS PER MSMED ACT : MICRO/ SMALL/ MEDIUM
REGN NO. :
VALID UPTO :
(Attach Certificate)

5.0 TOTAL ORGANISATIONAL STRENGTH : (ATTACH ORGANISATION CHART)

- | | GRADUATE | DIPLOMA | SKILLED | NON-SKILLED |
|--|----------|---------|---------|-------------|
| ENGINEERING : | | | | |
| MANUFACTURING : | | | | |
| QUALITY : | | | | |
| COMMERCIAL /
SERVICE AFTER SALES : | | | | |
| OTHERS : | | | | |
| TOTAL : | | | | |
| * 5.1 POWER BACKUP :
(GIVE DETAILS) | YES/ NO | | | |
| * 5.2 DOES THE COMPANY SELL ITS PRODUCT DIRECTLY : | YES/ NO | | | |

SUPPLIER'S AUTHORISED SIGNATORY

BHEL CERTIFIED ASSESSOR

**BHARAT HEAVY ELECTRICALS LIMITED
SUPPLIER REGISTRATION FORM**

FORM NO. SRF(I) 01 (INDIAN SUPPLIER)

ANNEXURE - 5

Page 5 of 17

ORGANISATIONAL INFORMATION

6.0 OTHER PARTICULARS :

(FURNISH DETAILS AND ENCLOSE DOCUMENTARY EVIDENCE/ COPY OF CERTIFICATE FOR THE FOLLOWING)

* 6.1 IF THE COMPANY IS ALREADY REGISTERED WITH ANY OF BHEL UNITS, GIVE :

6.1.1. BHEL UNIT'S NAME :

6.1.2. SUPPLIER REGN. CODE NO. :

6.1.3. ITEMS FOR WHICH REGISTERED & THEIR SPECIFICATION
(ENCLOSE PROOF OF SUCCESSFUL EXECUTION OF
ONE OR MORE PURCHASE ORDERS):

* 6.2 IS THE COMPANY APPROVED BY
ASME / NTPC / NPC / EIL / DGS&D / RAILWAYS /
IBR / LLOYDS ETC FOR INTENDED
MATERIAL CATEGORY? : YES / NO
(ENCLOSE DOCUMENTARY EVIDENCE)

* 6.3 IS THE COMPANY ISO 9001 APPROVED? : YES / NO
(ENCLOSE CERTIFICATE & TOC OF QUALITY SYSTEM) :

* 6.4 IS THE COMPANY AN ISO 14000 APPROVED? : YES / NO
(ENCLOSE CERTIFICATE) :

* 6.5 IS THE COMPANY OHSAS - 18000 APPROVED?: YES / NO
(ENCLOSE CERTIFICATE)

* 6.6 TECHNICAL COLLABORATOR :
(FOREIGN OR INDIGENOUS)
(ENCLOSE DOCUMENTARY EVIDENCE)

* 6.7 R&D SET UP

6.8 DIRECTORS / PARTNERS, IF RELATED TO ANY
BHEL EMPLOYEE.

NAME :

STAFE NO. :

DESIGNATION :

Unit & DEPARTMENT :

RELATIONSHIP :

SUPPLIER'S AUTHORISED SIGNATORY

BHEL CERTIFIED ASSESSOR

**BHARAT HEAVY ELECTRICALS LIMITED
SUPPLIER REGISTRATION FORM**

FORM NO. SRF(I) 01 (INDIAN SUPPLIER)

ANNEXURE - 5

Page 6 of 17

ORGANISATIONAL INFORMATION

6.9 IF ANY EX-BHEL PERSONNEL IS EMPLOYED BY THE COMPANY, MENTION HIS / HER DETAILS OF LAST POSTING.

NAME :
STAFF NO. :
DESIGNATION :
UNIT & DEPARTMENT :
DATE OF LEAVING SERVICE :

6.10 COMPANY'S WEEKLY HOLIDAYS :

WORKS OFFICE

6.11 EXPERIENCE LIST:

(ATTACH LIST OF PRESENT CUSTOMERS WITH NAME & ADDRESS FOR OFFERED / SIMILAR TYPE & SIZE OF ITEM / EQUIPMENT FOR WHICH REGISTRATION HAS BEEN SOUGHT AND WITH WHOM YOU HAVE CONTINUOUS BUSINESS SINCE LAST THREE YEARS . ALSO ATTACH PERFORMANCE CERTIFICATES ISSUED BY ANY TWO CLIENTS FOR SUCCESSFUL EXECUTION OF THE CONTRACTS FOR LAST TWO YEARS- FOR PEM)

*6.12 DETAILS OF PENDING LEGAL ISSUES ON CONTRACTUAL ASPECTS WITH CUSTOMER , IF ANY

6.13 The following information of Bank Account of the Company, duly endorsed by the Bank (required for Electronic Fund Transfer –EFT/RTGS) is to be submitted

1. Name of the Company
2. Name of Bank
3. Name of Bank Branch
4. City/Place
5. Account Number
6. Account type
7. IFSC code of the Bank Branch
8. MICR Code of the Bank Branch
9. Details of other Bankers (for reference purpose only)

NOTE :

(i) Suppliers who have already submitted the above information are requested to submit a copy of the same.

SUPPLIER'S AUTHORISED SIGNATORY

BHEL CERTIFIED ASSESSOR

**BHARAT HEAVY ELECTRICALS LIMITED
SUPPLIER REGISTRATION FORM**

FORM NO. SRF(I) 01 (INDIAN SUPPLIER)

ANNEXURE - 5

Page 7 of 17

ORGANISATIONAL INFORMATION

7.0 MANUFACTURING FACILITIES:

***7.1 LIST OF MANUFACTURING FACILITIES/EQUIPMENTS (INCLUDING MATERIAL HANDLING FACILITY)**

SL. NO	DESCRIPTION OF MACHINE/EQUIPMENT	QUANTITY	MAKE & YEAR OF INSTALLATION	REMARKS

IN CASE OF SPACE LIMITATION, PLEASE ENCLOSE ANNEXURE / CATALOGUE WITH TAG

*** 7.2 IF IN-HOUSE MFG FACILITIES NOT AVAILABLE, INFORM SOURCE OF MFG. DETAILS ALONGWITH THEIR FACILITIES & EXPERIENCE**

SL. NO	PROCESS OUTSOURCED	NAME OF THE COMPANY	DESCRIPTION OF MACHINE / EQUIPMENT	REMARKS

IN CASE OF SPACE LIMITATION ENCLOSE ANNEXURE / CATALOGUE WITH TAG

*** 7.3 RATIO OF OUTSOURCED COST TO TOTAL PRODUCTION VALUE:**

SUPPLIER'S AUTHORISED SIGNATORY

BHEL CERTIFIED ASSESSOR

**BHARAT HEAVY ELECTRICALS LIMITED
SUPPLIER REGISTRATION FORM**

FORM NO. SRF(I) 01 (INDIAN SUPPLIER)

ANNEXURE - 5

Page 8 of 17

ORGANISATIONAL INFORMATION

8.0 INSPECTION & TESTING FACILITIES:

*** 8.1 LIST OF INSPECTION & TESTING FACILITIES / EQUIPMENT**

SL. NO	DESCRIPTION OF FACILITY/ EQUIPMENT & CAPACITY	NOS.	MAKE & YEAR OF MANUFACTURING	LAST DATE OF CALIBERATION

IN CASE OF SPACE LIMITATION ENCLOSE ANNEXURE / CATALOGUE WITH TAG

*** 8.2 IF IN-HOUSE TESTING FACILITIES NOT AVAILABLE, INDICATE SOURCE OF TESTING ALONGWITH THEIR FACILITIES & EXPERIENCE**

SL. NO	TEST	SOURCE OF TESTING	DESCRIPTION OF FACILITY/ EQUIPMENT & CAPACITY	APPROVAL OF EQUIPMENT/ PROCESS/PERSONNEL QUALIFICATION

IN CASE OF SPACE LIMITATION ENCLOSE ANNEXURE / CATALOGUE WITH TAG

Note:

In case of outsourcing of major testing such as NDT, Electrical & Mechanical Testing, no marks will be awarded. However, material composition testing by chemical method from recognized laboratory shall not attract negative marking

SUPPLIER'S AUTHORISED SIGNATORY	BHEL CERTIFIED ASSESSOR
---------------------------------	-------------------------

**BHARAT HEAVY ELECTRICALS LIMITED
SUPPLIER REGISTRATION FORM**

FORM NO. SRF(I) 01 (INDIAN SUPPLIER)

ANNEXURE - 5

Page 9 of 17

ORGANISATIONAL INFORMATION					
FINANCIAL INFORMATION FOR THE PREVIOUS FOUR YEARS					
9.0	Parameter	Year 1	Year 2	Year 3	Year 4
		(Years in ascending order, Money value in Rs. Lakhs)			
* 9.1	NET WORTH (Share Capital +Reserves)				
	Growth over previous year (%)	-----			
9.2	LONG TERM DEBT / LOAN				
* 9.3	DEBT EQUITY RATIO <u>Long term Debt (9.2)</u> <u>Net worth (9.1)</u>				
9.4	INVESTMENT IN: Land & Building				
	Plant & Machinery				
	Other Fixed Assets				
9.5*	NET CURRENT ASSETS				
	1 a) Cash on hand				
	b) Account receivable				
	c) Inventories				
	Total				
	CURRENT LIABILITY				
	2 a) Sundry creditors				
	b) Interest accrued but not due				
	c) Other liabilities				
	Total				
* 3	* QUICK RATIO <u>CA - INVENT. {9.5(1)-9.5(1)c}</u> <u>Current liability {9.5 (2)}</u>				
* 9.6	SALES				
	Growth over previous year (%)	-----			
* 9.7	PROFIT BEFORE TAX				
	Growth over previous year (%)	-----			
* 9.8	Whether the supplier has been referred to BIFR / NCLT / any other Govt agency (If YES , enclose details)				YES / NO
* 9.9	Whether the supplier is a potential sick company.(If YES , enclose details)				YES / NO
NOTE: 1. Copies of annual accounts (Balance Sheet) for the last four years (or from date of incorporation which ever is less) along with audit report are to be submitted. The above details shall be highlighted in the Balance Sheet. 2. Status of Tax assessments done under various laws (Income Tax, VAT/Sales Tax, Excise & Service Tax, Custom) and details of disputes pending, if any, with these authorities to be submitted.					
SUPPLIER'S AUTHORISED SIGNATORY			BHEL CERTIFIED ASSESSOR		

**BHARAT HEAVY ELECTRICALS LIMITED
SUPPLIER REGISTRATION FORM**

FORM NO. SRF(I) 01 (INDIAN SUPPLIER)

ANNEXURE - 5

Page 10 of 17

ORGANISATIONAL INFORMATION

10. LIST OF ENCLOSURES (Tags to be put on enclosures) :

- (i) MEMORANDUM AND ARTICLES OF ASSOCIATION / SOCIETY RULES AND BYE LAWS / PARTNERSHIP DEED/ PROFESSION TAX REGN & MUNICIPAL REGN. : YES / NO
- (ii) Copy of certificate of following:-
 - x PERMANENT ACCOUNT NO : YES / NO
 - x CENTRAL SALES TAX REGN NUMBER : YES / NO
 - x STATE SALES TAX / TIN NUMBER : YES / NO
 - x EXCISE DUTY REGN NUMBER : YES / NO
 - x EXCISE CONTROL CODE NUMBER : YES / NO
 - x SERVICE TAX REGN NUMBER : YES / NO
 - x REGN NUMBER OF CATEGORY AS PER MSMED ACT : YES / NO
- (iii) ORGANISATION CHART : YES / NO
- (iv) If registered with any other BHEL Unit,
 - x LETTER OF REGISTRATION WITH BHEL UNIT : YES / NO
 - x PROOF OF SUCCESSFUL EXECUTION OF ONE OR MORE PURCHASE ORDERS : YES / NO
- (v) Letter of approval from ASME / NTPC / NPC / EIL / DGS&D / RAILWAYS /IBR / LLOYDS ETC : YES / NO
- (vi) Accreditation certificate for
 - x ISO: 9001 : YES / NO
 - x TOC of Quality System Manual : YES / NO
 - x ISO : 14000 : YES / NO
 - x OHSAS , ISO 18000 : YES / NO
- (vii) Letter regarding technical collaboration : YES / NO
- (viii) Experience List / Performance certificate : YES / NO
- (ix) Balance Sheet for the last four years along with audit Report : YES / NO
- (x) Principal's authorization in case of dealers/ agents : YES / NO
- (xi) EFT Bank's certificate : YES / NO

I /WE GIVE THE UNDERTAKING THAT BHEL DRAWINGS & SPECIFICATIONs SHALL NOT BE USED IN ANY WAY DETRIMENTAL TO THE INTEREST OF BHEL AND/ OR FOR SUPPLY OF ANY MATERIAL, PRODUCT OR SERVICES DIRECTLY OR INDIRECTLY TO ANY OTHER CUSTOMER.

Maximum Marks = 50
Negative Marks = -13
Minimum Qualifying marks = 30

**BHARAT HEAVY ELECTRICALS LIMITED
SUPPLIER REGISTRATION FORM**

FORM NO. SRF(I) 01 (INDIAN SUPPLIER)

ANNEXURE - 5

Page 11 of 17

FORM NO. SRF(I) 01

Part B (QUALITY SYSTEM):

Sl. No	PARAMETERS	SYSTEM IN EFFECT (Tick if exists & provide evidences if ticked in written procedure)		RECORDS (Tick if available & submit evidences)	REMARKS
		Written Procedure	Practice		
1*	Incoming Material Control System				Furnish a copy of system and organization.
2*	In process control				Furnish at least one work instruction & record of process control parameter
3*	Manufacturing / Testing Procedure Qualification				Procedure Qualification specification may be submitted
4*	Personnel qualification for 3 above.				Record of Personnel qualification (PQR) to be submitted
5*	Calibration system				Submit list of instrument & their calibration status
6*	System of Identification & Traceability of materials, tools, jigs, fixtures & processed components, etc.				Copy of procedure to be submitted
7*	System of Storage, Preservation , Painting & packing				Copy of procedure to be submitted
8*	System of NCR disposition & corrective preventive action				Two copies of NCR & CAPA
9*	Customer complaints handling system				Submit list of customer complaints & status for the last three years
10*	Safety measures				Submit copy of safety system & Record of accidents for last three years
11	Any other quality initiative				

SUPPLIER'S AUTHORISED SIGNATORY

BHEL CERTIFIED ASSESSOR

**BHARAT HEAVY ELECTRICALS LIMITED
SUPPLIER REGISTRATION FORM**

FORM NO. SRF(I) 01 (INDIAN SUPPLIER)

ANNEXURE - 5

Page 12 of 17

FORM NO. SRF(I) 01

Part B (QUALITY SYSTEM):

12. LIST OF ENCLOSURES

- (i) Copy of system of control incoming materials and organization chart
- (ii) Copy of at least one process control work instruction
- (iii) Record of process control parameter
- (iv) Copy of at least one Procedure Qualification specification
- (v) Record of Personnel qualification (PQR)
- (vi) List of instrument & their calibration status
- (vii) Copy of procedure for Identification & Traceability of materials, tools, jigs, fixtures & processed components, etc.
- (viii) Copy of procedure for Storage/ preservation/ painting & packing
- (ix) Copies of two NCRs and their CAPA.
- (x) List of customer complaints & status for the last three years
- (xi) Copy of safety system
- (xii) Record of accidents for last three years

Maximum Marks = 25

Minimum Qualifying marks = 15

SUPPLIER'S AUTHORISED SIGNATORY

BHEL CERTIFIED ASSESSOR

**BHARAT HEAVY ELECTRICALS LIMITED
SUPPLIER REGISTRATION FORM**

FORM NO. SRF(I) 01 (INDIAN SUPPLIER)

ANNEXURE - 5

Page 13 of 17

FORM NO. SRF(I)01

Part C : TECHNICAL COMPETENCE

Technical competence shall be evaluated in two parts viz. common competence and product/material category specific competence.

(i) COMMON TECHNICAL COMPETENCE (Max Marks: 10)

TECHNICAL COMPETENCE (where design specification is given by BHEL)	MARKING RANGE	SUPPLIER RESPONSE (ALONG WITH SUPPORTING DOCUMENTS)#	MARKS BY BHEL
1. Supplier understands the product specification.	(0-3)		
2. Supplier understands the inspection requirements.	(0-2)		
3. Supplier has process capability to achieve the product specification/dimensional requirement.	(0-3)		
4. Supplier has experienced manpower to carry out the job.	(0-2)		
TOTAL MARKS OUT OF POSSIBLE (10) = ---			

OR

TECHNICAL COMPETENCE (where performance specification is given by BHEL)	MARKING RANGE	PROCEDURE		SYSTEM IN EFFECT		RECORDS	
		SUPPLIER RESPONSE (ALONG WITH SUPPORTING DOCUMENTS)#	MARKS BY BHEL	SUPPLIER RESPONSE (ALONG WITH SUPPORTING DOCUMENTS)#	MARKS BY BHEL	SUPPLIER RESPONSE (ALONG WITH SUPPORTING DOCUMENTS)#	MARKS BY BHEL
1. Design capability	(0-3)						
2. Adequacy of quality assurance plan	(0-2)						
3. Process capability for components	(0-3)						
4. Adequate of testing	(0-2)						
TOTAL MARKS OUT OF POSSIBLE (10)							
Average of Total (Total/3) = -----							

(ii) PROUCT/ MATERIAL CATEGORY SPECIFIC TECHNICAL COMPETENCE

(Max Marks: 15)

Unit MISCC to structure the parameters to be considered for the technical competence depending on material category. The score of individual parameter selected is to be decided by MISCC. MISCC shall identify the requirement of enclosures to be furnished by supplier

Product:

Sl. No	Material category	Tech Parameter	Supplier's response	Remarks

To be filled up only on receipt of technical requirements/ specification, drawings, standards from BHEL and to be sent to BHEL for further scrutiny. Enclose documentary evidence where ever required.

LIST OF ENCLOSURES:

Maximum Marks = 25

Minimum Qualifying marks = 15

No marks is to be given by the supplier. Only supplier response along with supporting documents,

SUPPLIER'S AUTHORISED SIGNATORY	BHEL CERTIFIED ASSESSOR
---------------------------------	-------------------------

**BHARAT HEAVY ELECTRICALS LIMITED
SUPPLIER REGISTRATION FORM**

FORM NO. SRF(I) 01 (INDIAN SUPPLIER)

ANNEXURE - 5

Page 14 of 17

Part D : SCORE SHEET

1. ORGANISATIONAL SOUNDNESS (for Manufacturers):

S.N.	PARAMETER	CRITERIA	Maxm. Marks	Marks Awarded
1.	Whether all relevant information like ownership, PAN no., sales tax no., excise duty no., etc. submitted	Yes: 2 No: 0	2	
2.	3.4 YEAR OF COMMENCEMENT OF BUSINESS	More than 5 years : 2 1-5 years : 1 Less than 1 year : 0	2	
3.	5.1 POWER BACKUP	Yes : 1 No : 0	1	
4.	5.2 DOES THE COMPANY SELL ITS PRODUCT DIRECTLY	Yes : 1 No : 0	1	
5.	6.1 REGISTERED WITH ANY OF BHEL UNITS	Yes (same item) : 2 Yes (another item) : 1 No : 0	2	
6.	6.2 APPROVAL BY ASME/ NTPC/ NPC/ EIL/ DGS&D/ RAILWAYS/ IBR/ LLOYDS ETC	Yes : 2 No : 0	2	
7.	6.3 ISO 9001 ACCREDITATION	Yes : 3 No : 0	3	
8.	6.4 ISO 14000 ACCREDITATION	Yes : 1 No : 0	1	
9.	6.5 OHSAS - 18000 ACCREDITATION	Yes : 1 No : 0	1	
10.	6.6 TECHNICAL COLLABORATOR : (FOREIGN OR INDIGENOUS)	Yes : 1 No : 0	1	
11.	6.7 R & D SET UP	Yes : 1 No : 0	1	
12.	6.12 PENDING LEGAL ISSUES ON TECHNO – COMMERCIAL ASPECTS WITH CUSTOMER	Yes : -5 No : 0	0	
13.	7.1 & 7.2 MANUFACTURING FACILITIES INCLUDING OUTSOURCING	Adequate : 3 Substantial : 2 Inadequate : 0	3	
14.	7.3 RATIO OF OUTSOURCED COST TO TOTAL PRODUCTION VALUE	Less than 10% : 2 10 to 30 % : 1 More than 30% : 0	2	
15.	8.1 INSPECTION & TESTING FACILITIES	Adequate : 2 Substantial : 1 Inadequate : 0	2	
16.	8.2 OUTSOURCING OF MAJOR TESTING FACILITY (Refer Note)	Yes : 0 No : 1	1	
	TOTAL		25	

1. ORGANISATIONAL SOUNDNESS (for Indian Stockist/ Trader/ Distributor/ Dealer/ Authorised Agent/ Channel partner/ Indian Sales office or Subsidiary of registered foreign principal):

S.N.	PARAMETER	CRITERIA	Maxm. Marks	Marks Awarded
1.	Whether all relevant information like ownership, PAN no., sales tax no., etc. submitted (clause 6.0 of chapter V to be referred in this regard)	Yes: 7 No: 0	7	
2.	3.4 YEAR OF COMMENCEMENT OF BUSINESS	More than 3 years : 2 1-3 years : 1 Less than 1 year : 0	2	
3.	6.1 REGISTERED WITH ANY OF BHEL UNITS	Yes (same item) : 2 Yes (another item) : 1 No : 0	2	
4.	6.2 APPROVAL BY ASME/ NTPC/ NPC/ EIL/ DGS&D/ RAILWAYS/ IBR/ LLOYDS ETC	Yes : 2 No : 0	2	
5.	6.3 ISO 9001 ACCREDITATION	Yes : 2 No : 0	2	
6.	6.12 PENDING LEGAL ISSUES ON TECHNO – COMMERCIAL ASPECTS WITH CUSTOMER	Yes : -5 No : 0	0	

BHEL CERTIFIED ASSESSOR

**BHARAT HEAVY ELECTRICALS LIMITED
SUPPLIER REGISTRATION FORM**

FORM NO. SRF(I) 01 (INDIAN SUPPLIER)

ANNEXURE - 5

Page 15 of 17

Part D: SCORE SHEET

2. FINANCIAL INFORMATION (for Manufacturers):

S.N.	PARAMETER	CRITERIA	Maximum Marks	Marks Awarded
1.	9.1 Growth of Net Worth over previous year (%) Average of three years to be worked out	More than 20 % : 5 10 – 20 % : 4 5 – 10 % : 3 > 0 & < 5 % : 2 0 or below : 0	5	
2.	9.3 DEBT EQUITY RATIO <u>Long term Debt (9.2)</u> Net worth (9.1)	1 : 1 : 5 1.1 upto 1.5 : 1 : 4 1.6 upto 2.0 : 1 : 3 2.0 & above : 1 : 2	5	
3.	9.5 QUICK RATIO <u>CA - INVENTORIES {9.5(1)-9.5(1)c}</u> Current liability {9.5 (2)}	1 : 1 : 5 1 : 1 upto 1.5 : 4 1 : 1.5 upto 1.75 : 3 1 : 1.75 upto 2.5 : 2 1 : > 2.5 : 0	5	
4.	9.6 Growth in Sales over previous year (%) Average of three years to be worked out	More than 35% : 5 20 -35 % : 4 10 – 20 % : 3 5 – 10 % : 2 > 0 & < 5 % : 1 0 or negative : 0	5	
5.	9.7 PROFIT BEFORE TAX Growth over previous year (%)	More than 20 % : 5 10 – 20 % : 4 5 – 10 % : 3 > 0 & < 5 % : 2 0 or below : 0	5	
6.	9.8 Whether the supplier has been referred to BIFR / NCLT/ any other similar Govt agency	Yes: -5 No : 0	0	
7.	9.9 Whether the supplier is a potentially sick company	Yes: -3 No : 0	0	
TOTAL			25	

Note: If the supplier is new in business and does not have past data, then the evaluation will be done on the basis of information provided by him and will be decided by MISCC.

2. FINANCIAL INFORMATION (for Indian Stockist/ Trader/ Distributor/ Dealer/ Authorised Agent/ Channel partner/ Indian Sales office or Subsidiary of registered foreign principal):

S.N.	PARAMETER	CRITERIA	Maximum Marks	Marks Awarded
1.	9.6 Growth in Sales over previous year (%) Average of three years to be worked out	More than 35% : 5 20 -35 % : 4 5 - 20 % : 3 >0 - 5 % : 2 0 or negative : 0	5	
2.	9.7 PROFIT BEFORE TAX Growth over previous year (%)	More than 20 % : 5 5 – 20 % : 4 >0 – 5 % : 3 0 or below : 0	5	

BHEL CERTIFIED ASSESSOR

**BHARAT HEAVY ELECTRICALS LIMITED
SUPPLIER REGISTRATION FORM**

FORM NO. SRF(I) 01 (INDIAN SUPPLIER)

ANNEXURE - 5

Page 16 of 17

Part D : SCORE SHEET

3. QUALITY SYSTEM :

S.N.	PARAMETER	CRITERIA	Maxm. Marks	Marks Awarded
1.	Incoming Material control System	System availability : Yes: 1 No : 0	1	
		Availability of Organisation chart Yes: 1 No : 0	1	
2.	Process control	Work instruction available: Yes: 1 No : 0	1	
		Record of process Control : Available : 2 Partial record : 1 Not available: 0	2	
3.	Manufacturing / Testing Procedure Qualification	Procedure Qualification Specification : Adequate : 3 In adequate: 1 Not available : 0	3	
4.	Personnel qualification	Record of PQR: Adequate : 3 In adequate: 1 Not available : 0	3	
5.	Calibration system	Adequate : 3 In adequate: 1 Not available : 0	3	
6.	System of Identification & Traceability of materials, tools, jigs, fixtures & processed components, etc.	Procedure available : Adequate : 2 In adequate: 1 Not available : 0	2	
7.	System of Storage/ preservation/ painting & packing	Procedure available : Adequate : 2 In adequate: 1 Not available : 0	2	
8.	System of NCR disposition & corrective preventive action	Two copies of NCR & CAPA Available : 2 Not available : 0	2	
9.	Customer complaints handling system	System available : Yes: 1 No : 0	1	
		Complaints registered & resolved : 2 Complaints registered & partially resolved : 1 Complaints not registered or not resolved : 0	2	
10.	Safety measures	System available : Yes: 1 No : 0	1	
		Record available : Yes: 1 No : 0	1	
TOTAL			25	

BHEL CERTIFIED ASSESSOR

**BHARAT HEAVY ELECTRICALS LIMITED
SUPPLIER REGISTRATION FORM**

FORM NO. SRF(I) 01 (INDIAN SUPPLIER)

ANNEXURE - 5

Page 17 of 17

Part D : SCORE SHEET

4. TECHNICAL COMPETENCE

Column no. 1 to 4 to be filled by MISCC before sending to supplier. Column no. 5 to be filled by BHEL certified Assessor after evaluation of supplier response.

Sl. No (1)	Parameter (2)	Scoring criteria (3)	Maximum Marks (4)	Marks obtained (5)
	TOTAL		25	

SUMMARY:

Sl. No	Criteria	Maxm Marks	Qualifying marks *	Marks obtained	Recommendation for registration
1.	Organisational Soundness	50	30		Recommended : Permanent code /Development code/ Trial code Not recommended
	Financial Information				
2.	Quality System	25	15		
3.	Technical Competence	25	15		
	TOTAL	100	60		

***Minimum Qualifying Score in Each category shall be 60%.**

REGISTRATION CRITERIA:

Sl. No	Score	Recommendation
1.	More than 90	Supplier is to be registered and given Permanent code, Normally no visit is called for.
2.	>75 <=90	Supplier may be visited if recommended by MISCC or to be registered and given permanent code.
3.	>=60 <=75	Supplier may carry out suggested improvements if advised by MISCC Supplier's visit is mandatory. Trial/ Development code may be given.
4.	Less than 60	Not to be registered

Note: Indian Stockist/ Trader/ Distributor/ Dealer/ Authorised Agent/ Channel partner/ Indian Sales office or Subsidiary of registered foreign principal are to be awarded marks on pro-rata basis and registered accordingly.

Signatures: MISCC and Suppler Evaluation Team (in case of visit)

1)

2)

3)

4)

5)

6)

BHEL CERTIFIED ASSESSOR

ANNEXURE - 6

NON-DISCLOSURE AND PROPRIETARY INFORMATION AGREEMENT

BETWEEN

_____ (Name of the Vendor), having its registered offices in
_____ (Address of Vendor), registered under the no.
of the Companies' register of _____ (Name of Place and Country),
capital stock of _____ (Value), with a place of business in
_____ (Name of Place and Country) (hereinafter referred to as
" _____ (Name of Vendor)");

AND

Bharat Heavy Electricals Ltd a company incorporated under the Indian Companies Act 1956 having its registered offices at BHEL House, Siri Fort, New Delhi -110 049 and having one of its works at Heavy Electrical Equipment Plant, Ranipur, Haridwar-249403 (Uttarakhand), India registered under the No. 4281 of 1964-65 of the companies register of Delhi, capital stock of Rs 4895.2 million with a place of registered office in New Delhi (hereinafter referred to as "BHEL") hereinafter also referred to individually as "the Party" or collectively as "the Parties".

BACKGROUND

This Agreement sets forth the rights and obligations of the Parties with respect to the use, handling, protection and safeguarding of Proprietary Information that is disclosed by and between the Parties.

WHEREAS

A) the Parties wish to pursue exploratory discussions concerning a possible collaboration between them in relation to the Program defined in Exhibit 1;

B) during the ensuing discussions and negotiations it may occur that either Party discloses to the other technical, financial or business information of a proprietary or confidential nature, which the Parties intend to protect against, making it available, by any means to any third person, and other unauthorized use and/or further disclosure by the recipient, in accordance with the terms and conditions set forth herein;

NOW, THEREFORE, the Parties have agreed as follows:

1. The term “Proprietary Information” shall mean any information or data of whatsoever kind of a confidential or proprietary nature, including but not limited to, commercial information, know how and technical information in the form of designs, drawings, concepts, requirements, specifications, software, interfaces, components, processes, or the like, that have been or will be disclosed by either Party to the other pursuant to this Agreement, either in writing, orally or other form, which is designated as “Proprietary” or “Confidential” by the disclosing Party by means of formal declaration or an appropriate stamp, legend or any other written or orally notice .

2. Proprietary Information may be conveyed, without limitation, through any written or printed documents, samples, models, electronic form on disk, tape, other storage media or any other means of disclosing such Proprietary Information that either Party may elect to use during the life of this Agreement, but if an originating Party originally discloses information orally or visually, the receiving Party will protect such information as Proprietary Information to the extent that the originating Party :
 - identifies the Information as Proprietary at the time of original disclosure,
 - summarizes the Proprietary Information in writing .

Information stored in electronic form on disk, tape, other storage media will be adequately marked if a proprietary legend displays when the information originally runs on a computer system and when the information is printed from its data file.

Proprietary Information also includes any information which can be obtained by examination, testing or analysis of any hardware or material substance or any component part of such hardware or material substance provided by the Disclosing Party even though the requirements in Clause 1 for marking and designation have not been fulfilled.

3. Each Party, to the extent of its rights to do so, shall disclose to the other only the Proprietary Information which the disclosing Party deems appropriate to fulfil the objectives of this Agreement. The Parties hereby represent that the disclosure of Proprietary Information by and between themselves shall be made in compliance with, and subject to the laws and regulations of the Disclosing Party's country.

4. The receiving Party hereby agrees and covenants that, from the effective date of this Agreement until the expiry date as per article 11 and the following period as per article 12, the Proprietary Information that either Party receives from the other shall:
 - a) be protected and kept in strict confidence by the receiving Party which must use the same degree of care it uses to protect its own confidential information and in no case less than a reasonable care;

 - b) be only disclosed to and used by those persons within the receiving Party's organization or that of its parent or controlled companies who have a need to know and solely for the purposes specified in this Agreement, and be treated by such persons or entities with the same degree of care and subject to the same restrictions;

 - c) to procure that each third party to whom Proprietary Information is disclosed under this Agreement is made aware of the provisions of this Agreement prior to such disclosure to it and that each such third party is

bound by obligations of confidentiality which are no less onerous than those contained in this Agreement;

- d) neither be disclosed nor caused to be disclosed or made available, either directly or indirectly, to any third Party or persons other than those mentioned in subparagraph b) above or other persons upon which both of the contractual Parties shall agree in an amendment to this Agreement;
- e) not to copy, reproduce or reduce to writing any part of such Proprietary Information except as may be reasonably necessary for the purpose referred to in the Recitals of this Agreement

PROVIDED THAT the Receiving Party shall be entitled to make any disclosure required by court order or government or regulatory requirement of the Disclosing Party's Proprietary Information subject to notifying the Disclosing Party as soon as possible of such requirement

- 5. Any Proprietary Information and copies thereof disclosed by either Party to the other shall remain the property of the disclosing Party and shall be immediately returned or destroyed by the receiving Party upon request.
- 6. The receiving Party shall have no obligations or restrictions with respect to any Proprietary Information for which the receiving Party can prove that:
 - a) is in or which comes into the public domain otherwise than as a result of a breach of this Agreement by any person to whom a disclosure of Proprietary Information is made as permitted under this Agreement or of any other duty of confidentiality relating to the Proprietary Information of which the Receiving Party has knowledge; or
 - b) it has been in its possession without restriction at the time of the disclosure, as evidenced by written documentation in its files; or
 - c) it has been lawfully received from a third Party without breach of this Agreement; or

- d) it has been or is published without violation of this Agreement; or
 - e) it has been independently developed in good faith by employees of the receiving Party who did not have access to the Proprietary Information; or
 - f) it has not been properly declared, designated or confirmed as Proprietary or Confidential; or
 - g) the protection period has expired according to articles 11 and 12 of this Agreement.
7. With respect to any exchange of Proprietary Information which may occur as a result of this Agreement, it is expressly understood and agreed that the persons listed in Exhibit 2 shall, on behalf of the respective Parties, be the exclusive individuals authorized to receive from and transmit to the other Party Proprietary Information under this Agreement. Each Party may replace at any time its respective authorized individuals identified in such Exhibit 2, within its own organization. Any such new designation by a Party shall be made by written notice to the other at the address indicated in such Exhibit 2.
8. Any Proprietary Information which is identified as “Classified Information”, or whose export is subject to an export license, shall be identified as such by the disclosing Party at the time of disclosure and the disclosure, protection, use and handling thereof, shall remain subject to the security procedures and restrictions imposed by the disclosing Party's Government.
9. The disclosure of Proprietary Information under this Agreement by either Party to the other shall not be construed as granting to the receiving Party any right, whether express or implied by licence or otherwise, on the matters, inventions or discoveries to which such information pertains, or as granting any trademark, patents, copyrights, trade secret right or other form of intellectual property right.

10. Nothing in this Agreement may be construed as an obligation of either Party to disclose any Proprietary Information to the other, or to enter into any subsequent contractual relationship with such other Party.
11. This Agreement covers the exchange of Proprietary Information which may be made by either Party to the other until ten years from signing of the agreement or any extension thereto which may be agreed upon by the Parties in writing. Proprietary information relevant to the Program detailed in Exhibit 1, already made available to the other contractual Party before the effective date, shall also be protected under this Agreement.

It is understood by the parties that, prior to disclosure, the Disclosing Party shall have obtained any government authorisation needed for the export of the Proprietary Information

12. The expiry of the period contemplated in Article 11 of this Agreement shall not relieve the receiving Party from complying with the obligations imposed by Article 4 here above with respect to the use and protection of the Proprietary Information, received prior the date of such expiry, for a period of ten (10) years after such expiry.
13. The Parties are independent contractors. Each will bear all costs and expenses in connection with this Agreement. This Agreement is intended to facilitate only the exchange of Proprietary Information and is not intended to be, and shall not be construed to create a teaming agreement, joint venture, association, partnership, or other business organisation or agency arrangement and no Party shall have the authority to bind the other without the other Party's separate prior written agreement .
14. This Agreement shall be governed by and shall be interpreted in accordance with the substantive federal laws of Switzerland excluding it's choice of law rules.

Irrespective of the foregoing each Party shall remain bound by the provisions of its own national laws and regulations with respect to the transfer or use of Classified Information or information whose export is subject to an export license.

15. All disputes among the Parties, in connection with or arising out of the existence, validity, construction, performance and termination of this Agreement (or any terms thereof), which the Parties are unable to resolve among themselves, shall be finally settled by an Arbitration. The Arbitration shall be held in Geneva (CH) in English language, in accordance with the rules of the ICC – International Chamber of Commerce by three arbitrators appointed in accordance with said rules.
16. The foregoing constitutes the entire Agreement among the Parties with respect to the subject matter hereof and supersedes and cancels all prior representations, negotiations, commitments, undertakings, communications, either oral or written, acceptances, understandings and agreements among the Parties with respect to or in connection with any of the matters to which such Agreement applies or refers.
17. Notices to _____ (**Name of Vendor**) shall be made at the following address:

(Complete Address of Vendor)

Attention: Mr. _____ (**Name of the Authorised Person of Vendor**)

Notices to BHEL shall be made at the following address:

BHARAT HEAVY ELECTRICALS LIMITED,

HEAVY ELECTRICAL EQUIPMENT PLANT,

Ranipur, Haridwar-249403 (Uttarakhand), India

Attention: Shri B.M.Bansal, General Manager- Materials Management

18. The effective date of this Agreement shall be the date of the last signature appearing herein.

IN WITNESS WHEREOF, each of the Parties has caused this Agreement, to be executed by its duly authorized officer.

Date :

Signed for and on behalf of

Signed for and on behalf of

(Name of Vendor)

BHEL

By:

By:

Title:

Title:

Signature:

Signature:

EXHIBIT 1

to the

NON-DISCLOSURE AGREEMENT

between

_____ **(Name of Vendor)**

and

BHARAT HEAVY ELECTRICALS LIMITED

dated:

The Non Disclosure Agreement covers the exchange of Proprietary Information which may occur during the discussions and negotiations in view of a possible cooperation between the Parties in the following programs:

-Description of Material or Services for which the order is placed

_____ **(Name of Vendor)** list of products that require an exchange of Proprietary Information which may be occur during the discussions and negotiations in view of a possible cooperation for the above programs :