



**BHARAT HEAVY ELECTRICALS LIMITED**  
**HEEP HARIDWAR INDIA-PIN 249403**  
**FAX NO: 0091 1334 226462**  
**PHONE NO: 0091 1334 284658**

Enq. No.: **T/T206/2015/1398W/1**

Date of issue : 02/02/2016

M/S.....

Sub: BHEL-HEEP/OPEN-TENDER (COMPONENT)/2015

Dear Sir,

The Heavy Electricals Equipment Plant (HEEP) located in Haridwar, India is one of the major manufacturing plants of Bharat Heavy Electricals Ltd. The core business of HEEP includes design and manufacture of large steam and gas turbines, turbo generators and so on.

Sealed tenders with the Tender No. and opening date clearly super scribed on the cover are invited from the manufacturers (registered as well as unregistered) for the supply of the following items:-

Sl. No.	Tender No.	Description of Item	Qty.	Opening Date
1	T/T206/2015/1398W/1	W90311322131 DRG. 11132236004 REV. 01 VALVE CONE SPEC: HW19683 REV. 01	02 NO.	29/02/2016
		W90311320180 DRG. 21132036001 REV. 00 VALVE CONE SPEC: HW19683 REV. 01	02 NO.	

The details with required delivery are given in **Annexure-1**.

The tender documents can be downloaded from our web site [www.bhel.com](http://www.bhel.com) or [www.bhelhwr.co.in](http://www.bhelhwr.co.in) or [www.tenders.gov.in](http://www.tenders.gov.in), after downloading the tender documents from web site, while submitting the tender as detailed in "Instruction to Bidders", intending vendors must remit Earnest Money Deposit (EMD) of Rs. 1,50,000.00 against each tender in the form of Pay Order / Demand draft only. **If EMD are not submitted than the offer may be out rightly rejected.** As per notification reference no. NSIC/HO/GP/15(4)/2013-14 dated 07.07.2013 Micro & Small Enterprises (MSEs) is not required to submit EMD. A certificate issued from competent authority shall be submitted in support of Micro & Small Enterprises (MSEs). BHEL will not be responsible for any type of postal delay / incomplete information from vendor.

Central / State – PSUs / Government departments are exempted from submission of EMD subject to approval by BHEL management.

PMD vendors registered with HEEP, Haridwar for above mentioned material code vide vendor code M06179, M23110, M72060, M80093 & R19122 are exempted from submitting of EMD.

**The date for opening of tender shall be 29.02.2016.** Tenders will be received up to 1.45 P.M. on **29.02.2016** and opened on the same day at 2.00 P.M. in the Tender Room. **Please note that tender received after due date & time (1.45 PM on 29.02.2016) will not be REPEAT will not be opened.** BHEL will not be responsible for any type of postal / courier delay.

Specifications & Drawing of the above items are available on our above mentioned website. Other cross referred documents can be physically collected from BHEL, Haridwar by submitting the tender fee of Rs. 2000.00 by Pay Order or Demand Draft in favor of BHEL, Haridwar or can be obtained by email [akhilkg@bhelhwr.co.in](mailto:akhilkg@bhelhwr.co.in) or [studu@bhelhwr.co.in](mailto:studu@bhelhwr.co.in). Amendments/Corrigendum, if any, will be hosted on our web site only. Other terms and conditions will be as per tender documents.

**The total quantity may undergo change at the time of ordering.**

**Any vendor who is under suspension at the time of price bid opening, their price bid shall not be opened.**

**Documents submitted with the offer/ bid by the bidder shall be ink signed and stamped in each page by authorized representative of the bidder. Documents not signed and stamped in each page by the authorized signatory of the bidder, shall not be accepted and considered for evaluation of the bid.**

Please submit your Techno-Commercial offer only for the above requirement subject to our terms and conditions.

BIDS shall be opened at 2 PM on the due date in the presence of authorized representative of the bidders who may like to be present. The authorized representative should bring authority letter from their parent company (Manufacturer) for the specific tender no. attending the bid opening.

BHEL will forfeit the EMD if, the successful bidder / vendor refuses to honor the order after award of the same on him and / or withdraws his bid and / or unilaterally changes the offer and / or any of its terms & conditions within the validity period.

**KINDLY READ "INSTRUCTIONS TO BIDDERS." QUOTATION NOT IN ACCORDANCE WITH THE INSTRUCTIONS ARE LIABLE TO BE DISQUALIFIED AND IGNORED.**

## INSTRUCTIONS TO BIDDERS FOR OPEN TENDER

### 1.0 DEFINITION

Registered Vendors - Are those who are registered with BHEL, Haridwar for Megawatt rating/ Size/ Weight of tendered components in respective steel grade or machining of such components.

Un-registered Vendors - Are those who are not registered with BHEL, Haridwar for Megawatt rating/ Size/ Weight of tendered components in respective steel grade or machining of such components.

### 2.0 TECHNICAL QUALIFICATION

- Enclosed format – Annexure-2 & Annexure-3 to be submitted. It is the mandatory requirement. Offer of Vendors not meeting these requirements may not be considered.

### 3.0 ESSENTIAL INSTRUCTIONS

1. All un-registered vendors shall be approved by BHEL, if found suitable, on the basis of data furnished by them in Supplier Registration Form (SRF) Foreign Vendors or Indigenous Vendors. Vendor (s) shall not be considered for ordering if not approved by BHEL.
2. BHEL team may visit the vendor (s) works for verification of capability and capacity claimed in tender documents/offer (s).
3. The tenders shall be submitted in two parts as described below on or before the due date. Vendor Registration Form shall be submitted by unregistered vendors only.

#### i. Part I (Envelop I) –

##### A. EMD

or

Valid certificate towards exemption of EMD, applicable for Micro and small Enterprises, as mentioned below:

MSE Suppliers can avail the intended benefits only if they submit along with the offer, attested copies of either EM II certificate having deemed validity (five years from the date of issue of acknowledgement in EM II) or valid NSIC certificate or EM II certificate along with attested copy of a CA certificate (format enclosed where deemed validity of EM II certificate of five years has expired) applicable for the relevant financial year (latest audited). Date to be reckoned for determining the deemed validity will be the date of bid opening (Part 1 in case of two part bid). Non submission of such documents will lead to disqualification of their offer. Documents should be notarized or attested by a Gazetted Officer.

##### B. Pre-Qualifying Requirement (PQR) – refer Annexure – 2.

C. Vendor Registration Form (SRF documents to be placed separately in part-I and not to be mixed with other documents).

##### D. Techno -Commercial Bid

#### ii. Part II (Envelop II) - Price Bid

4. The Quotation should be from the Principal / Original Manufacturer, failing which the quotation is likely to be ignored. However, if OEM / Principal insist on engaging the services of an agent, such agent shall not be allowed to represent more than one manufacturer / supplier in the same tender. Moreover, either the agent could bid on behalf of the manufacturer / supplier or the manufacturer / supplier could bid directly but not both. In case bids are received from both, the manufacturer / supplier and the agent, bid received from the agent shall be ignored. In Case the quotation is submitted through agent, the quotation must accompany original authorization letter from the Principal / Original Manufacturer.
5. The bidders will have to submit ink-signed offer / bid in original directly to BHEL. **Unsigned bids shall be ignored.**

6. The suppliers or their authorized person may be allowed to attend the tender opening, if duly authorized by their principals, through a specific letter for a particular enquiry or for specific price bid opening on that particular day. General authorization letter is not acceptable
7. Any corrections / amendments shall be properly & fully authenticated with signature. No overwriting is acceptable.
8. Compliance of technical/ commercial terms and conditions as per Annexure-3
9. Part-I will be opened on the date and time specified in the tender notice in the presence of those vendors who wish to attend.
10. Part-II (Price Bids) along with supplementary price bids, if necessary, will be opened at a later date of only those bidders who successfully qualify the PQR requirements, their techno commercial bid has been found acceptable and have submitted EMD or valid certificate towards exemption of EMD, applicable for Micro and small Enterprises.
11. Vendor to quote best possible deliveries in the offer. Offers of those vendors may not be considered if it is not found suitable to BHEL requirement.
12. Currency exchange rate will be applicable on the date of opening of Part-I for evaluation purpose.
13. Depending upon the delivery suitability, BHEL reserves the right to split order on more than one vendor.
14. Evaluation of Bid: - The bid shall be evaluated
  - a. Cost to BHEL basis. ( Basic Cost + Insurance + Transportation + Duty )
  - b. The loading, if any, on account of LD penalty, payment terms or any other cost determined at later stage, which shall be communicated to the vendor.
15. Tenders when finalized shall be in the name of the bidder only and change of name during tender evaluation (without certificate from registrar of company) and after submission of the tender is liable to make the offer ineligible for participation.
16. All test certificates / Guarantee certificates to be submitted in TRIPLICATE along with dispatch documents.
17. BHEL reserves the right to open the price bid (part-II) along with the opening of techno-commercial offer at its option and in that case vendor will be informed accordingly.
18. BHEL reserves the right to go for reverse auction. Vendors are requested to give their best price. In case of failure of reverse auction the paper bid shall be processed. Bidder should clearly indicate their acceptance for reverse auctioning in Annexure-3. The bids of those vendors who do not agree for reverse auction may not be considered. The Terms & Condition for Reverse Auctioning are given below.
19. Total weight -- /Gross / Net in Kg. & also package size essentially should be indicated if not exact then approximate.
20. BHEL will evaluate the technical bids against essential criteria/requirements. BHEL may seek clarifications, if required, from the qualified bidders only. These clarifications will be communicated to the eligible vendors. The offers of those bidders, who are unable to respond in specified time frame, are likely to be ignored.
21. SETTLEMENT OF DISPUTES
  - Indigenous Vendors: In all cases of dispute the matter shall be referred for arbitration to any arbitrator to be appointed by the Executive Director or any officer who is the administrative head of Bharat Heavy Electricals Ltd., at Haridwar. The venue of arbitration shall invariably be Ranipur Haridwar. The award of the arbitrator shall be final and binding on both the parties. The arbitrator shall have the power to extend, from time to time, the time for making his award with the consent of the parties.
  - Foreign Vendors: In the event of any dispute or difference arising between the parties to this contract regarding execution of same or their respective rights and liabilities there under, the same shall except as otherwise expressly provided therein, be referred to the arbitration of the two arbitrators, one to be appointed by each party; or in the case of the said arbitrators not agreeing then an umpire to be appointed by the two arbitrators in writing before entering on that reference and provisions of the Indian Arbitration Act ,1940 or any statutory notification, or re-enactment therefore and rules framed there under from time to time shall apply to such arbitration . If the two arbitrators do not agree on the appointment of umpire, the nomination of the umpire shall be done by the International Chamber of Commerce, Paris(France).The decision of arbitrators, or in case of their not agreeing, that of the said umpire shall be binding both on seller and purchaser. The venue of the arbitration invariably be New Delhi.
22. JURISDICTION  
All question, dispute or differences arising under, out of or in connection with the purchase order shall be subject to the exclusive jurisdiction of Haridwar courts.
23. OVER RIDING CLAUSE  
All stipulations made in any correspondence other than those exchanged in regards to “instruction” in our tender documents / enquiry for submission of your offer, if at all shall be void

to the extent they are repugnant to the conditions contained herein above and in the purchase order.

24. FINALITY OF MANAGEMENT DECISION

At all places in the preceding clauses BHEL Management's decision shall be final.

**4.0 GENERAL INSTRUCTIONS**

**PART-I (EMD (or exemption certificate), PQR, SRF & Technical clarification in envelope - I) shall comprise of following documents:**

- a. EMD or exemption certificate (to be provided in separate envelope).
- b. Annexure-2 for Pre-qualification requirement. Point wise reply to all the points mentioned in Pre-Qualifying Requirement specified in the tender. Relevant documents as requested in Pre-Qualifying Requirement must be attached.
- c. Vendor Registration Form (SRF)  
(Kindly follow the link and follow instructions: <http://supplier.bhel.in/>)  
The SRF duly filled up will be assessed for manufacturing capability quality systems being followed, organizational soundness and financial worthiness. The same shall be submitted with Part-I by un-registered vendor only with BHEL, HEEP, Haridwar or the proof of submission through online portal. BHEL registered vendors (registered with permanent code M, N, S) need not to submit SRF.  
For vendors registered with T code, SRF is to be submitted essentially along with the offer.
- d. Non-disclosure agreement as per Annexure 6. The agreement shall be duly stamped & signed.
- e. Complete technical offer.
- f. Annexure-3 for compliance of technical/ commercial terms and conditions.
- g. Complete technical offer as per specification, drawings, technical requirement along with un-priced bid indicating CIF rate, separate Lloyd's/BV/TUV inspection charges (for Foreign vendors) and delivery schedule.
- h. Validity of offer to be indicated.
- i. Deviation with reference to specification/drawing, if any, should be clearly indicated on a separate sheet.
- j. Copy of price Bid (without prices).
- k. Any additional documents.

**PART -II (Price Bid)**

- a. Price bid with prices to be submitted as part-II of the tender.
- b. If price bid is not submitted along with Part-I bid, the offer will be rejected out rightly.
- c. In case of foreign vendors, prices to be quoted on CIF basis separately. In case of CIF, Loading port must be mentioned.
- d. In case of Indigenous vendor, prices must be quoted on FOR-Destination-CPS-HEEP-BHEL basis. However, the insurance will be arranged by BHEL. Vendor can dispatch good through any Indian Bank Association approved transporters having their branch at Haridwar / destination. For the convenience name and address of transporters approved by IBA and BHEL are posted at website [www.bhelhwr.co.in](http://www.bhelhwr.co.in). Further, non-availability of BHEL approved transporter will not be accepted for rescheduling of delivery or waiver of penalties.
- e. In case of foreign vendors, third party (Lloyd's/BV/TUV) inspection charges to be quoted separately as third party inspection (Lloyd's/BV/TUV) is in vendor's scope. For Indian vendors, inspection shall be by TUV/ BHEL nominated inspection agency. Prices shall be loaded by 0.18% on account of TUV/ BHEL nominated inspection agency inspection charges. Third Party inspection shall be in BHEL scope.
- f. Prices should remain firm till the execution of the order. However, in case vendor prefers to maintain their own PVC formula, they can do so. Vendors must give upper & lower cap. However, lower cap has to be either equal or more in percentage point than the upper cap from base prices. This is **must** for evaluation purpose. **Upper price limit** will be considered for evaluation purpose.
- g. Insurance during transportation shall be taken care of by BHEL.
- h. Applicable sales Tax, Excise duty, service tax, educational cess and any other statutory levy should be indicated separately and clearly in the quotation.
- i. **Prices are to be written in both Figures & Words. In case of any difference between the two, If there is a discrepancy between words and figures, the amount in words shall prevail for evaluation and establishing L1 status..**

- j. **LD Penalty shall be applicable at the rate of ½% (half percent) per week or part thereof subject to a maximum of 10% of the value of delayed portion of the order. In case of any variation in LD penalty acceptance, your prices shall be loaded to the extent LD penalty not accepted by you.**
- k. **Preferable payment term shall be “100% after receipt and acceptance of material”. BHEL as a rule do not agree to release advance payment.**
- l. **The comparison between foreign and indigenous bids shall be done based on the Total Landed cost at Destination basis.**

**Note:**

After tender opening (Part-I), if it is found that:

- The bidder has not submitted the requisite EMD (If applicable).
- The bidder has claimed to be an MSE vendor but no supporting documents have been submitted in this regard.

In both the above cases the offer of the bidder may be straightaway rejected and no correspondence from the bidder in this regard shall be entertained.

However, offer of the bidder shall be treated as per the guideline in case the bidder has claimed to be an MSE vendor and submitted requisite MSE documents.

BHEL reserves the rights to place order for tendered quantity on more than one vendor

**Superscription on envelopes:**

The following shall be super scribed on the envelopes:

**PART-I**

1. TENDER NO. AND ITEMS DESCRIPTION
2. DUE DATE FOR OPENING.
3. EMD (IF APPLICABLE) OR MSE CERTIFICATE TOWARDS EXEMPTION OF EMD
4. PRE- QUALIFYING REQUIREMENT (PQR)
5. SUPPLIER REGISTRATION FORM (SRF)
6. TECHNO-COMMERCIAL BID.

**PART- II**

1. TENDER NO. AND ITEMS DESCRIPTION
2. DUE DATE FOR OPENING OF PART-I
3. PRICE BID

The part-I & part-II shall be individually sealed and super scribed as indicated above and shall be enclosed further in the envelop duly sealed and super scribed as :

“TENDER FOR (ITEM NAME) AGAINST TENDER NO.----- DUE ON -----  
-----CONTAINING PART-I & PART-II OF THIS OFFER.” Vendor’s full name and address should be clearly mentioned on the envelope and shall be addressed to:

To,

Head of Materials Management,  
Heavy Electrical Equipment Plant,  
BHEL,  
Hardwar- 249403

Envelopes not marked as above are liable to be ignored and will not be opened.

**IN CASE YOU ARE NOT MAKING AN OFFER AGAINST THIS ENQUIRY, THEN PLEASE ARRANGE TO SEND A LETTER OF REGRET IF YOU HAVE COLLECTED THE TENDER DOCUMENTS FROM BHEL.**

## **TERMS AND CONDITIONS OF REVERSE AUCTIONING**

Against this enquiry for the subject item /system with detailed scope of supply as per enquiry specifications, BHEL may resort to "REVERSE AUCTION PROCEDURE" i.e., ON LINE BIDDING ON INTERNET.

- For the proposed reverse auction, technically and commercially acceptable bidders only shall be eligible to participate.
- BHEL will engage the services of a service provider who will provide all necessary training and assistance before commencement of on-line bidding on internet.
- BHEL will inform the vendor in writing in case of reverse auction, the details of Service Provider to enable them to contact & get trained.
- Business rules like event date, time, start price, bid decrement, extensions etc. also will be communicated through service provider for compliance.
- Vendors have to fax the Compliance form in the prescribed format (provided by Service provider) before start of Reverse auction. Without this, the vendor will not be eligible to participate in the event.
- BHEL will provide the calculation sheet (e.g., EXCEL sheet) which will help to arrive at "Total Cost to BHEL" like Packing & forwarding charges, Taxes and Duties, Freight charges, Insurance, Service Tax for Services and loading factors (for non-compliance to BHEL standard Commercial terms & conditions) for each of the vendor to enable them to fill-in the price and keep it ready for keying in during the Auction.
- Reverse auction will be conducted on scheduled date & time.
- At the end of Reverse Auction event, the lowest bidder value will be known on the network.
- The lowest bidder has to Fax the duly signed Filled-in prescribed format as provided on case-to-case basis to BHEL through Service provider within 24 hours of Auction without fail.
- Any variation between the on-line bid value and the signed document will be considered as sabotaging the tender process and will invite disqualification of vendor to conduct business with BHEL as per prevailing procedure.
- In case BHEL decides not to go for Reverse Auction procedure for this tender enquiry, the Price bids and price impacts, if any, already submitted and available with BHEL shall be opened as per BHEL's standard practice.

Annexure- 1

Sl. No.	Tender No.	Description of Item	Delivery Required	Qty. (No.)
1	T/T206/2015/1398W/1	W90311322131 DRG. 11132236004 REV. 01 VALVE CONE SPEC: HW19683 REV. 01	15/03/2016	02
		W90311320180 DRG. 21132036001 REV. 00 VALVE CONE SPEC: HW19683 REV. 01	15/03/2016	02

- **Vendor should quote best delivery.**

## Annexure – 2

### Pre – Qualification Requirement

**Material Code – W90311320180 & W90311322131:-**

**Vendors must mandatorily satisfy the following criteria. Otherwise, their offer may not be considered.**

#### **I. Experience criteria:-**

1. Vendor must have experience of coating and hard facing on any one of the following material grades – GX12CrMoVNbN 9-1, 21CrMoV5-7, 21CrMoNiV4-7, X22CrMoV12-1, X10CrMoVNb9-1, X12CrMoWVNbN 10-1-1, X19CrMoVNbN11-1, G17CrMoV5-10, GX10CrMoVNb9-1, GX12CrMoWVNbN10-1-1.
2. The vendor must have experience of Ni-Cr coating by HVOF process on material grades referred at point 1.
3. The vendor must have experience of HS 75-25 coating by HVOF process on material grades referred at point 1.
4. The vendor must have experience of hard facing of ENiCrFe3 or Stellite on material grades referred at point 1.
5. The vendor must have experience of supplying of items having similar hard facing and HVOF coating & finishing requirements.
6. The vendor to submit the P.O. copies along with relevant documents showing experience details of supplying at least two components for satisfying each criteria referred at A1 to A5. It may be noted that same component may also be considered for satisfying more than one criteria of A1 to A5.
7. The submitted documents shall include P.O., customer name, year of supply & test certificates. Test certificates & documents of the above two items should be clearly indicating the following:-
  - a) For HVOF process: Coating type & consumables, coating thickness, details of process qualification carried out for the above processes like- Bond strength, Micro-structure, Chemistry, hardness;
  - b) For Hard-facing: Welding process and consumables, deposit thickness, WPS/ PQR for the welding/ Overlay of ENiCrFe3, Stellite on material grades referred at point 1. WPS shall be witnessed by 3<sup>rd</sup> party like Llyods/ TUV which may also include welder qualification, list of qualified welders for each process.

#### **II. Equipment Criteria:-**

1. The vendor must have in house Welding facility (TIG or SMAW) to cacter the requirement of subject items & furnish the equipment details.

2. The vendor must have in-house Heat treatment furnace facility to cater the requirement of subject items & furnish the equipment details. Furnace calibration certificate showing temperature uniformity within the furnace shall be submitted.
3. The vendor must have in-house Shot blasting facility to prepare the surface before HVOF spray to cater the requirement of subject items & furnish the equipment details.
4. The vendor must have in-house facility of HVOF process to cater the requirement of subject items & furnish equipment details.
5. The vendor must have following testing facilities (either in-house or outsourced from Government approved labs):- Hardness, DP dimensions.

The Vendors will have to source the Casting from BHEL approved sources as per Annexure-A.

The vendors are required to give clause wise confirmation against technical delivery conditions referred in 3-11239-56100 along with complying the technical requirements referred in respective BHEL drawings.

Drawing of the components referred at A-6 in support of experience may be submitted, if available.

### III.

	Qualifying Criteria proposed in context to machining requirements only:
	Vendors complying following requirements only should quote:
a.	Vendor should have manufacturing workshop having facilities for vertical boring, horizontal boring, Turning (lathe), drilling and cylindrical grinding operations. – Vendor to confirm.
b.	Vendor should have capability for carrying out following operations with suitable facilities as mentioned below:- Vendor to confirm against each Sr. no. “c” & “d” and provide broad specifications of referred facilities like make, model, specifications <b>(Vertical Borer-</b> Table dia., Turning height, Weight capacity; <b>Lathe-</b> Swing Over Carriage, center distance and weight capacity; <b>Horizontal Borer-</b> Spindle dia., Table size, Weight capacity, X-Axis, Y-Axis & Z-Axis Traverse; <b>Radial drill-</b> Drilling size capacity, power, working range; <b>Cylindrical Grinder-</b> Max. dia. and max. length, Weight Capacity)

c.

Sr. No.	Operations (for drawing no. 11132236002, of forging weight – 700 kg.)	Required
1.	Rough Turning (before metal coating): Max. dia. 580 mm and length 1253 mm.	Vertical Borer/ Lathe
2.	Finish Turning (after metal coating): Max. dia. 580 mm and length 1253 mm.	Vertical Borer/ Lathe
3.	Machining of peripheral body details.	Horizontal Borer

4.	Drilling of holes dia. 60 mm and M24 mm	Radical Drilling machine
----	---	--------------------------

d.

Sr. No.	Operations (for drawing no. 21132036002, of forging weight - 515 kg.)	Required
1.	Rough Turning and boring (before metal coating): Max. dia. 650 mm and length 890 mm.	Vertical Borer/ Lathe
2.	Finish turning and boring (after metal coating): Max. dia. 650 mm and length 890 mm.	Vertical Borer/ Lathe
3.	Machining of Internal and External Contours.	CNC Vertical Borer
4.	Cylindrical Grinding machine: Dia-359 mm, Length- 890 mm, Working length- 685 mm, Weight – 515 kg.	Cylindrical Grinder

#### IV.

1. Kindly submit quality plan in the enclosed format for BHEL review & approval. QPs are required to be submitted along with offer.
2. Inspection by third party (LRS/TUV/BV) for import and BHEL nominated agency (TUV) for indigenous as per BHEL approved QP.
3. Scope of TPI shall be:-
  - a) At casting supplier's works:-
    - Identification of test samples.
    - Witnessing of mechanical properties, NDT, hardness survey after weld repair (if any), dimensional check & review of remaining TCs as per ordering casting drawing/ specification.
  - b) At coating supplier works:-
    - Witnessing of dimensional check, surface finish, DPT, hardness check & review of all in-process checks as per ordering drawing, specification, TDC.

**BHEL approved sources**

1. EMIRATES TECHNO CASTING FZE, SHARJAH, UAE
2. VOESTALPINE GIESSEREI TRAISEN GMBH, TRAISEN, AUSTRIA
3. INOSSMAN FONDERIE ACCIAIO MANIAGO S.P.A. (GRUPPO CIVIDALE),  
MANIAGO(PN), ITALY
4. JAPAN CASTING AND FORGING CORPORATION, TOKYO, JAPAN
5. SCHMOLZ + BICKENBACH GUSS GMBH, KREFELD, GERMANY
6. SANDE STAHLGUSS GMBH, SANDE, GERMANY
7. GOODWIN STEEL CASTINGS LTD., ENGLAND
8. R. V. CASTING AND ENGINEERING PVT. LTD., FARIDABAD (HARYANA),  
INDIA
9. PEEKAY STEEL CASTINGS PVT. LTD., CALICUT, KERALA, INDIA
10. BALAJI SUPER ALLOYS, COIMBATORE, TAMIL NADU, INDIA
11. LITOSTROJ STEEL LTD., LJUBLJANA, SLOVENIA
12. STAR WIRE (INDIA) LTD., BALLABGARH (HARYANA), INDIA
13. BHARAT HEAVY ELECTRICALS LTD., CENTRAL FOUNDRY FORGE PLANT ,  
HARIDWAR, INDIA

10093-02-11320-36001  
DRAWING NO.

12.5 ALL OVER UNLESS OTHERWISE STATED

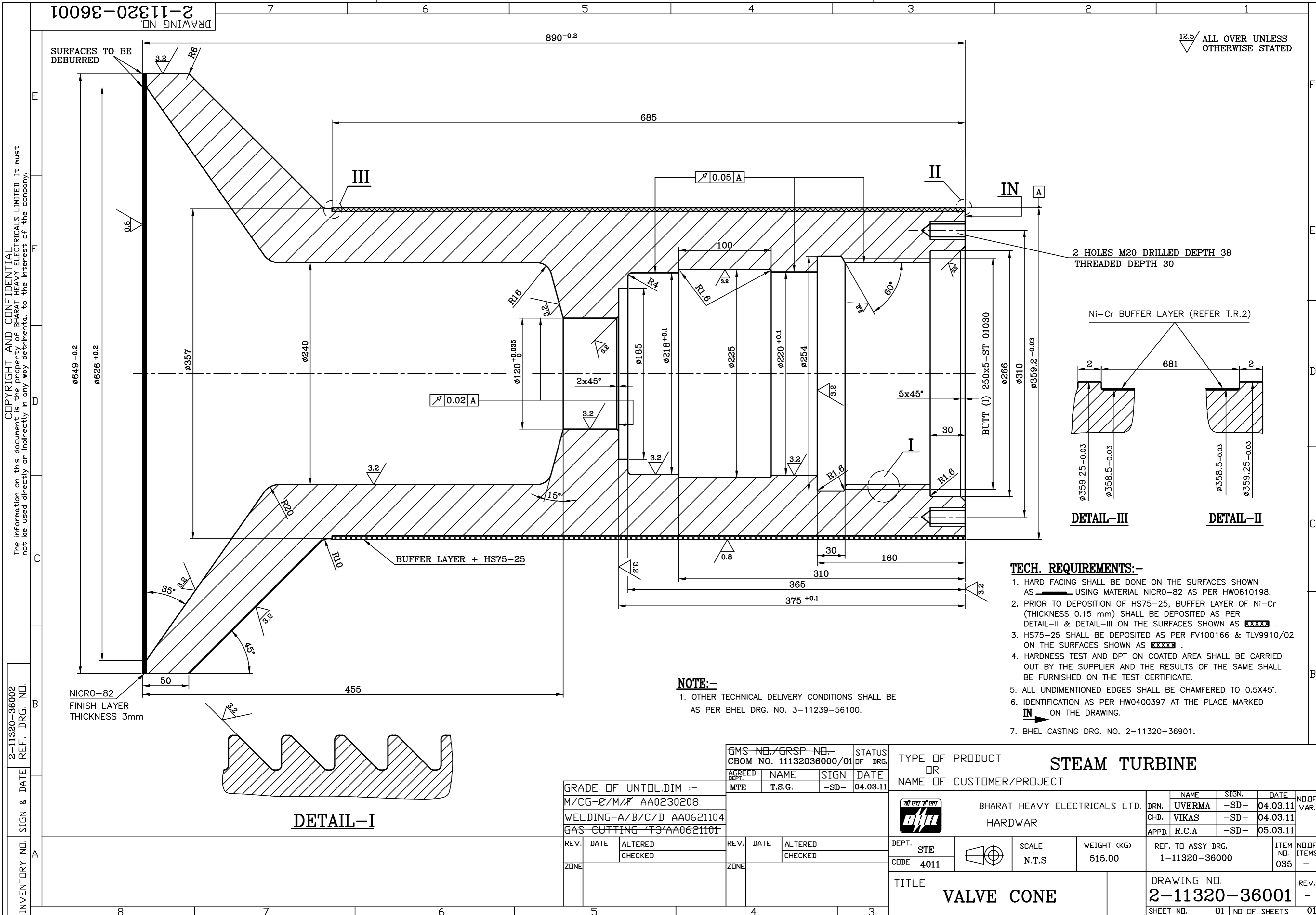

2 HOLES M20 DRILLED DEPTH 38  
THREADED DEPTH 30

Ni-Cr BUFFER LAYER (REFER T.R.2)

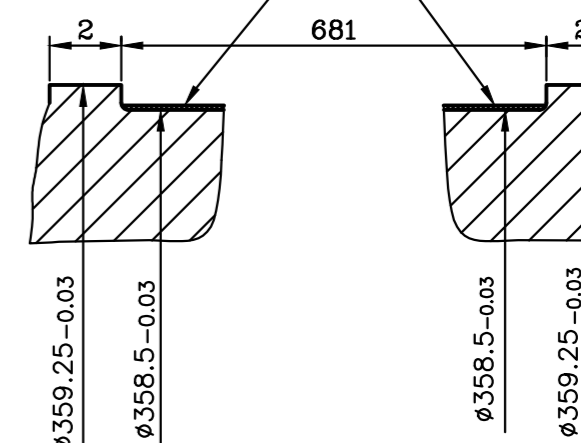

DETAIL-III

DETAIL-II

**TECH. REQUIREMENTS:-**

- HARD FACING SHALL BE DONE ON THE SURFACES SHOWN AS **XXXX** USING MATERIAL NICO-82 AS PER HW0610198.
- PRIOR TO DEPOSITION OF HS75-25, BUFFER LAYER OF Ni-Cr (THICKNESS 0.15 mm) SHALL BE DEPOSITED AS PER DETAIL-II & DETAIL-III ON THE SURFACES SHOWN AS **XXXX**.
- HS75-25 SHALL BE DEPOSITED AS PER FV100166 & TLV9910/02 ON THE SURFACES SHOWN AS **XXXX**.
- HARDNESS TEST AND DPT ON COATED AREA SHALL BE CARRIED OUT BY THE SUPPLIER AND THE RESULTS OF THE SAME SHALL BE FURNISHED ON THE TEST CERTIFICATE.
- ALL UNDIMENSIONED EDGES SHALL BE CHAMFERED TO 0.5X45°.
- IDENTIFICATION AS PER HW0400397 AT THE PLACE MARKED **IN** ON THE DRAWING.
- BHEL CASTING DRG. NO. 2-11320-36901.

**NOTE:-**

- OTHER TECHNICAL DELIVERY CONDITIONS SHALL BE AS PER BHEL DRG. NO. 3-11239-56100.

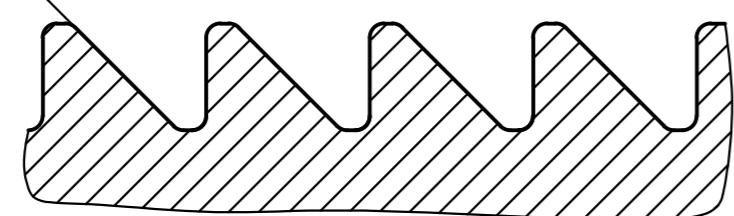

DETAIL-I

COPYRIGHT AND CONFIDENTIAL  
The information on this document is the property of BHARAT HEAVY ELECTRICALS LIMITED. It must not be used directly or indirectly in any way detrimental to the interest of the company.

INVENTORY NO. SIGN & DATE REF. DRG. NO. 2-11320-36002

GMS NO./GRSP NO. CBOM NO. 11132036000/01		STATUS OF DRG.		TYPE OF PRODUCT OR NAME OF CUSTOMER/PROJECT							
AGREED	NAME	SIGN	DATE	STEAM TURBINE HARDWAR							
MTE	T.S.G.	-SD-	04.03.11								
GRADE OF UNTOL.DIM :- M/CG-Ø/M/F AA0230208 WELDING-A/B/C/D AA0621104 GAS CUTTING-T3/AA0621101											
REV.	DATE	ALTERED	REV.	DATE	ALTERED	DEPT.	SCALE	WEIGHT (KG)	REF. TO ASSY DRG.	ITEM NO.	NO.OF ITEMS
		CHECKED			CHECKED	STE	N.T.S	515.00	1-11320-36000	035	-
TITLE VALVE CONE				DRAWING NO. 2-11320-36001				REV. -			
SHEET NO. 01				NO OF SHEETS 01				REV. -			

1-11322-36004  
DRAWING NO

✓ ALL OVER UNLESS OTHERWISE STATED

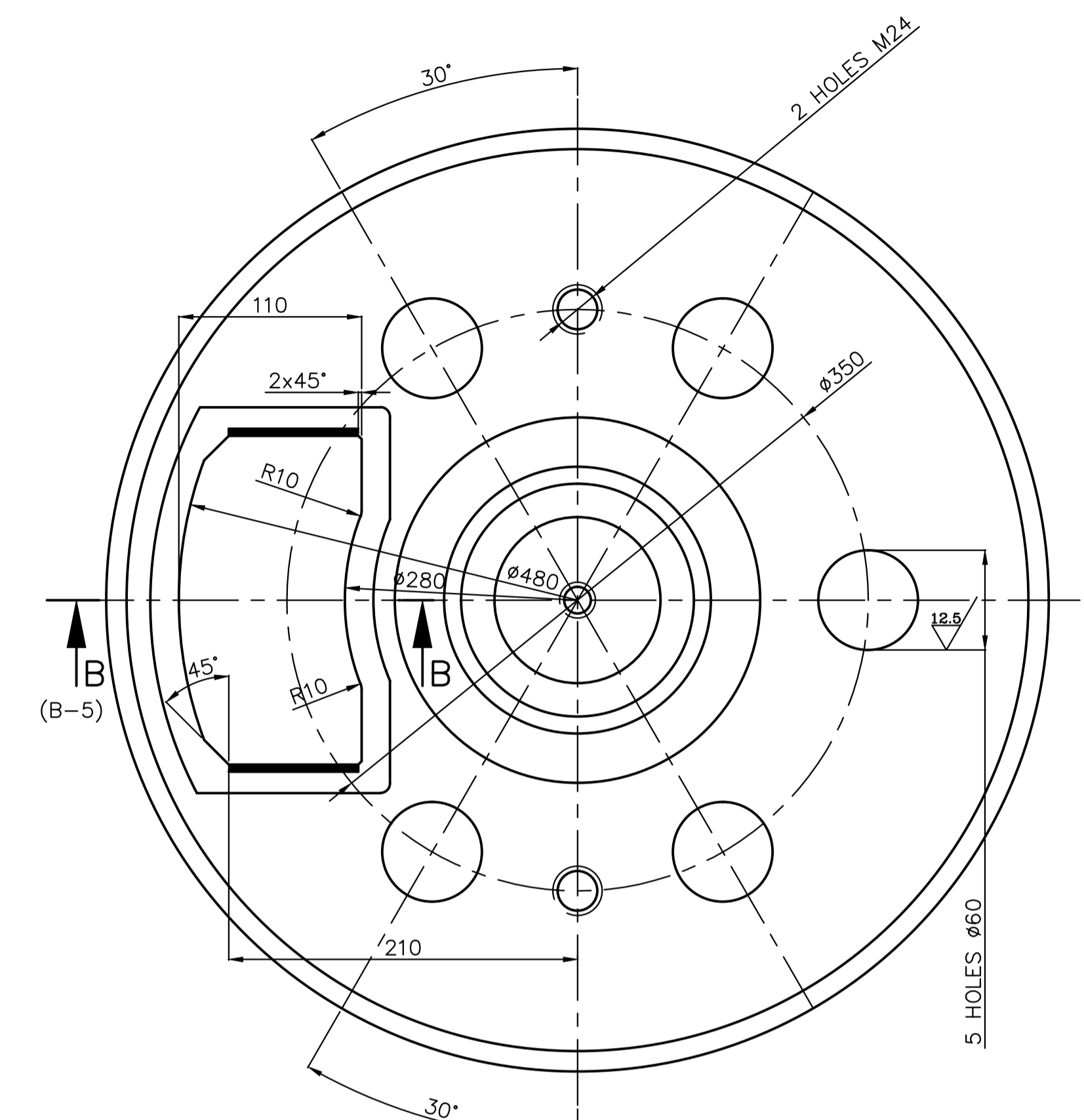
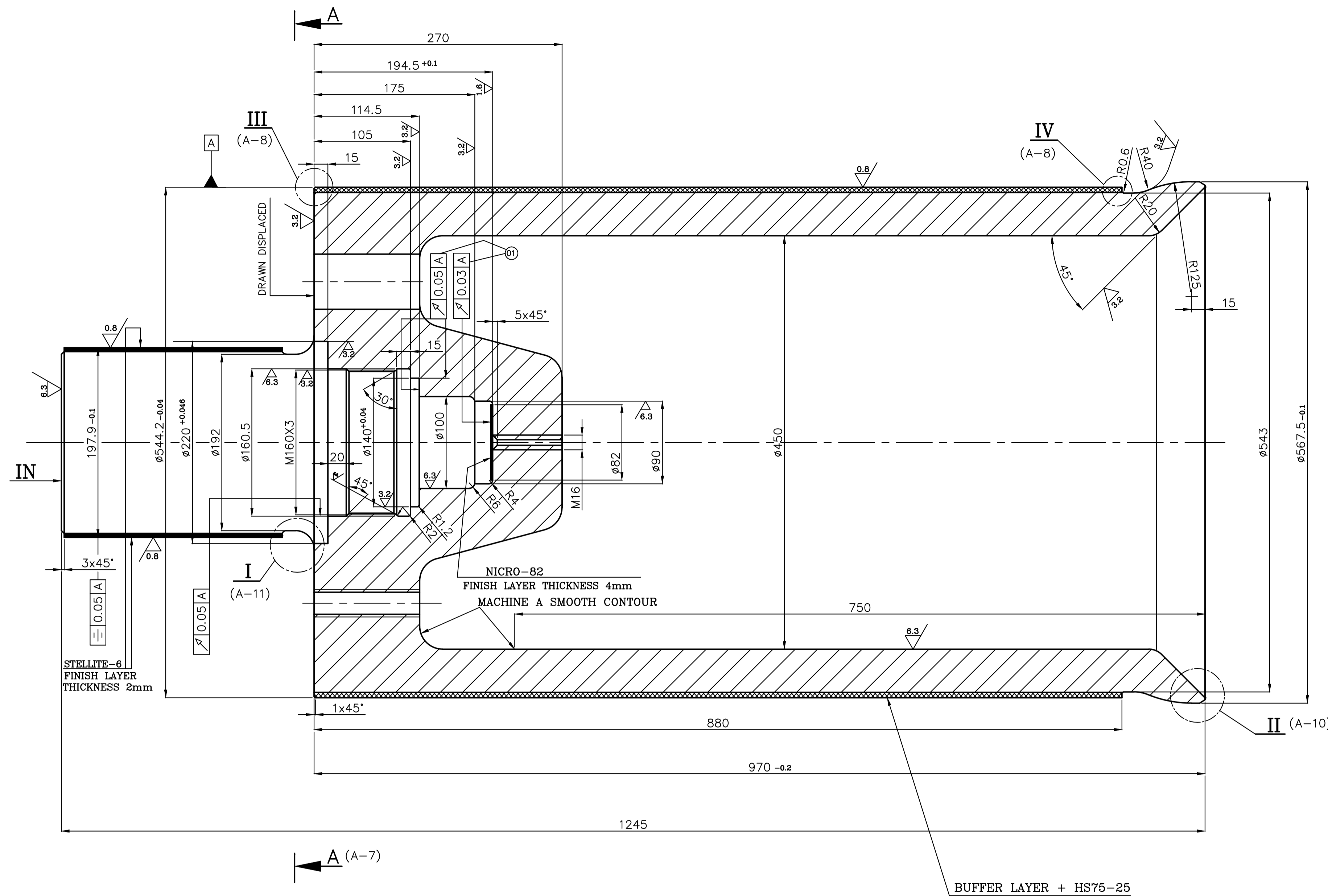

**TECH. REQUIREMENTS:-**

- HARD FACING SHALL BE DONE ON THE SURFACES SHOWN AS USING MATERIAL Ni-Cr-82 & STellite-6 AS PER HW0610198.
- PRIOR TO DEPOSITION OF HS75-25, BUFFER LAYER OF Ni-Cr (THICKNESS 0.15 mm) SHALL BE DEPOSITED AS PER DETAIL-III & IV ON THE SURFACES SHOWN AS .
- HS75-25 SHALL BE DEPOSITED AS PER FV100166 & TLV9910/02 ON THE SURFACES SHOWN AS .
- SURFACES MARKED ON THE DRAWING SHALL BE POLISHED AND TESTED FOR DEFECTS SUCH AS CRACKS ETC.
- HARDNESS TEST AND DPT ON COATED AREA SHALL BE CARRIED OUT BY THE SUPPLIER AND THE RESULTS OF THE SAME SHALL BE FURNISHED ON THE TEST CERTIFICATE.
- ALL UNDIMENSIONED EDGES SHALL BE CHAMFERED TO  $0.5 \times 45^\circ$ .
- IDENTIFICATION AS PER HW0400397 AT THE PLACE MARKED WITH **IN** ON THE DRG.
- BHEL CASTING DRG. NO. 2-11322-36901.

**NOTE:-**

- OTHER TECHNICAL DELIVERY CONDITIONS SHALL BE AS PER BHEL DRG. NO. 3-11239-56100.

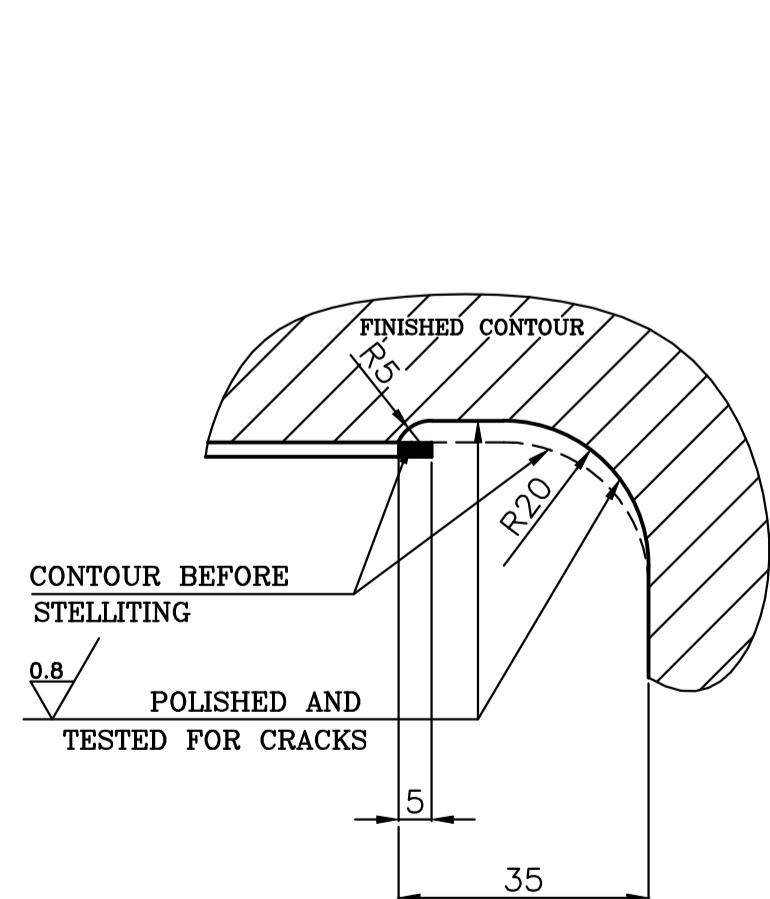

**DETAIL-I**  
(E-11)

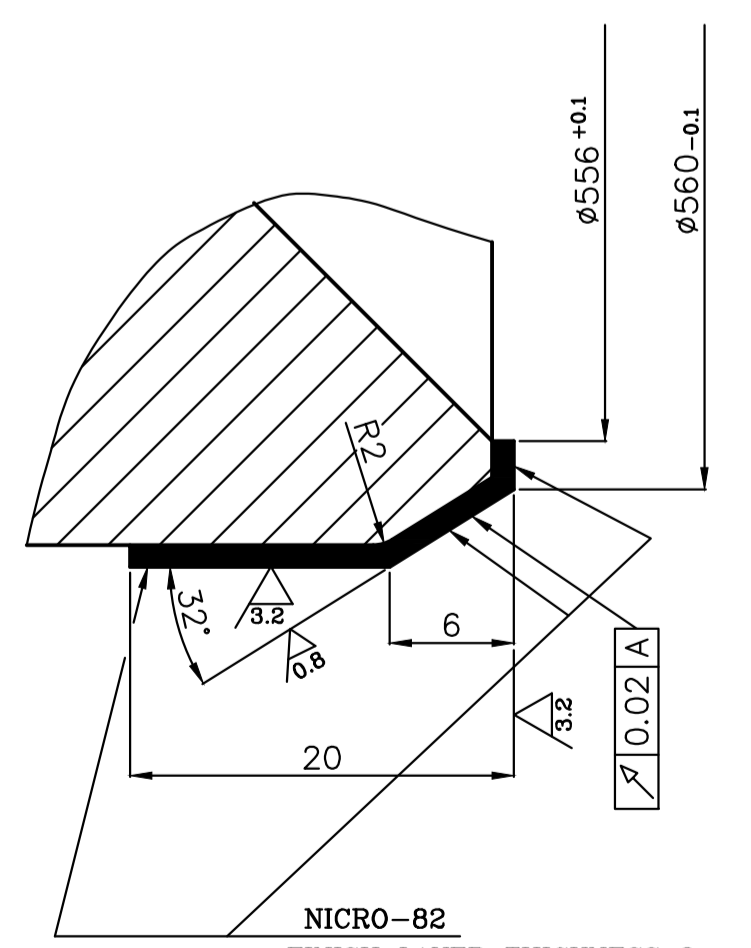

**DETAIL-II**  
(D-5)

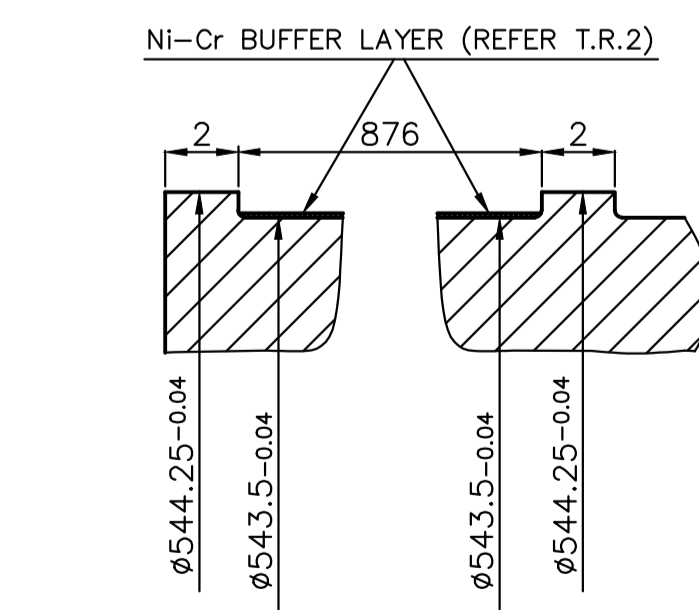

**DETAIL-III**  
(H-10)      **DETAIL-IV**  
(H-6)

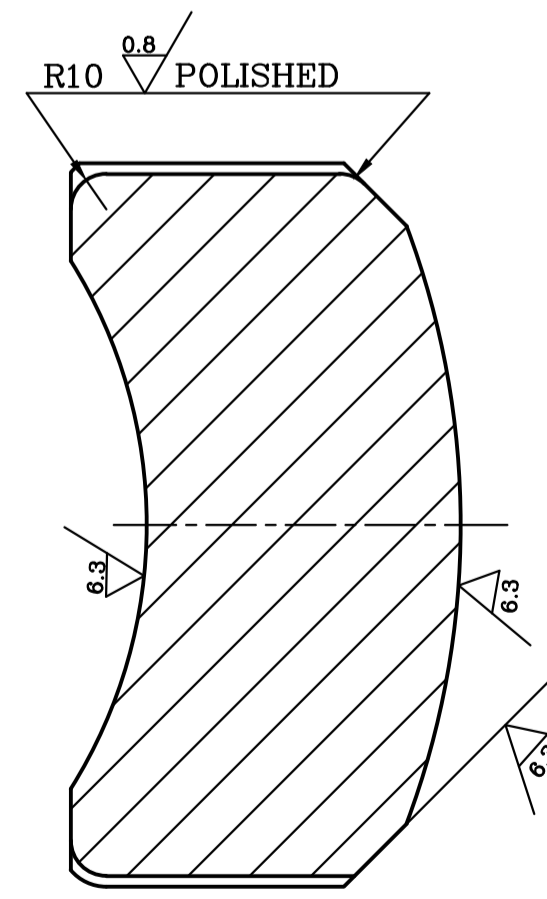

**SECTION A-A**  
(D-10)

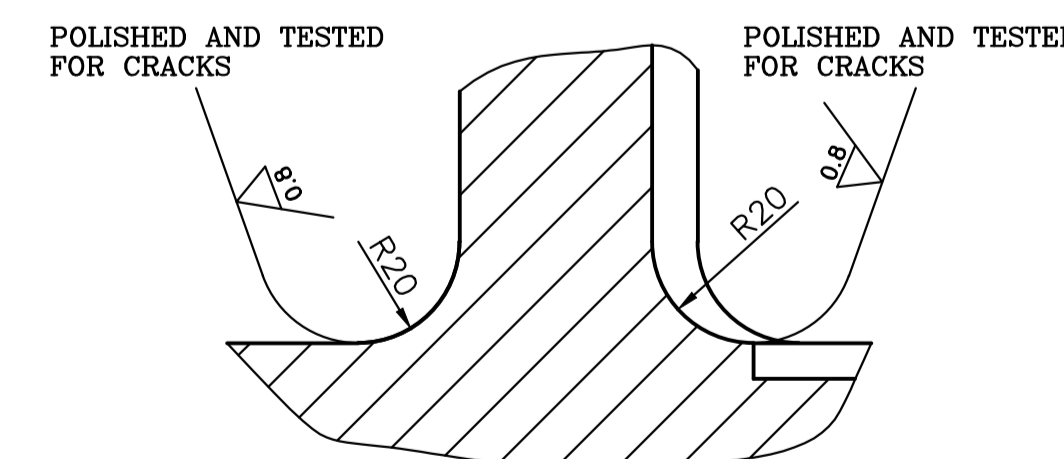

**SECTION B-B**  
(F-4)

GMS/GR-SP-ND- CBOM NO. 11132236000/01		STATUS OF DRG.		TYPE OF PRODUCT <input type="checkbox"/> OR <b>STEAM TURBINE</b>			
AGREED DEPT.	NAME	SIGN.	DATE	NAME OF CUSTOMER/PROJECT			
MTE	T.S.G.	-SD-	04.03.11	BHARAT HEAVY ELECTRICALS LTD.			
GRADE OF UNTOLD DIM:- MCG:-Z/M/P AA 0230208				DRN. UVERMA -SD- 04.03.11			
WELDING-A/B/C/D AA0621104				CHD VIKAS -SD- 04.03.11			
GAS CUTTING: T3'AA0621104				APPD. R.C.A -SD- 05.03.11			
REV	DATE	ALTERED	UVERMA	sd/-	DEPT.	SCALE	WEIGHT(KG)
	01	18.08.12	CHECKED	VIKAS	sd/-	N.T.S	700.00
CHANGED AS PER C/A NO. STE-12-F0320.				REF. TO ASSY DRG. 1-11322-36000		ITEM NO. 036	NO. OF ITEMS -
TITLE <b>VALVE CONE</b>						CARD CODE	DRAWING NO. <b>1-11322-36004</b>
						SHEET NO. 01	NO. OF SHEETS 01
						SIZE A1	

COPYRIGHT AND CONFIDENTIAL  
THE INFORMATION ON THIS DOCUMENT IS THE PROPERTY OF BHARAT HEAVY ELECTRICALS LIMITED IT MUST NOT BE USED DIRECTLY OR INDIRECTLY IN ANY WAY DETRIMENTAL TO THE INTEREST OF THE COMPANY.

INVENTORY NO. SIGN & DATE  
1-11322-36002 REF. DRG. NO.

दिनांक एवं हस्ताक्षर SIGN & DATE		संस्थान क्रय विनिर्देश (हीप - हरिद्वार)	HW 19683
		PLANT PURCHASE SPECIFICATION (HEEP - HARIDWAR)	मुख पृष्ठ PREFACE SHEET
शामली सूची संख्या को SUPERSEDES INVENTORY NO. अतिरिक्त करता है	<p align="center"><b>STEEL CASTING WITH IDENTIFICATION NUMBER (GX12CrMoVNbN 9-1)</b></p> <p align="center">केवल आंतरिक प्रयोग हेतु प्रदायक को देने से पूर्व इस मुखपृष्ठ को निकाल दें । FOR INTERNAL USE ONLY REMOVE THIS PREFACE BEFORE ISSUE TO SUPPLIERS.</p>		
COPYRIGHT AND CONFIDENTIAL. The information on this document is the property of Bharat Heavy Electrical Limited. It must not be used directly or indirectly in any way detrimental to the interest of the company.	समतुल्य मानक/सूची आदि } :NIL COMPARABLE STANDARDS / CATALOGUES ETC.		
	सुझाए/सम्भावित प्रदायक एवं श्रेणी } AS PER PMD SUGGESTED / PROBABLE SUPPLIERS AND GRADES.		
स्वत्वाधिकार एवं गोपनीय	कोई अन्य जानकारी } BASED ON TLV 9263 01 05/2001 ANY OTHER INFORMATIONS		
दिनांक एवं हस्ताक्षर SIGN & DATE 12/1/2010	सामली सूची संख्या INVENTORY NO. P-4088	स्वीकृति : संस्थान मानक समिति APPROVED : PLANT STANDARDS COMMITTEE	G.No. 2.10
Rev 01 06.01.10	निर्माण : PREPARED : MTE	जारी : मानक विभाग ISSUED : STANDARDS DIVISION	दिनांक : DATE : 4/12/09

SUPERSEDES INVENTORY NO. TLV 9263 01 06/2001

**STEEL CASTING WITH IDENTIFICATION NUMBER (GX12CrMoVNbN 9-1)**

COPYRIGHT AND CONFIDENTIAL  
 The information on this document is the property of Bharat Heavy Electrical Limited. It must not be used directly or indirectly in any way detrimental to the interest of the company.

**1.0 SCOPE OF APPLICATION**

The specification governs the quality of steel castings in material grade GX12CrMoVNbN 9-1 for turbine parts exposed to pressure.

**2.0 APPLICABLE REFERENCE DOCUMENT**

HW0980832

**3.0 CHEMICAL COMPOSITION**

Heat analysis in weight % shall be as follows:

<b>C</b>	0.11 - 0.14	<b>Si</b>	0.20 - 0.50	<b>Mn</b>	0.40 - 0.80
<b>P</b>	≤ 0.020	<b>S</b>	≤ 0.01	<b>Cr</b>	8.00 - 9.50
<b>Mo</b>	0.90 - 1.05	<b>V</b>	0.18 - 0.25	<b>Ni</b>	≤ 0.40
<b>Al<sub>tot</sub></b>	≤ 0.020	<b>Nb</b>	0.05 - 0.08	<b>N</b>	0.04 - 0.06

Ti, Sn, Cu and B shall be determined and reported for information only

**4.0 WELDING**

Welding as per approved WPS and PQR shall be performed only on quenched and tempered castings. Design welds are allowed only after permission from BHEL.

The welding filler materials shall be in accordance to the WPS. The available welding filler materials are:

- Cromocord 9 M (Oerlikon)
- Fox C 9 MV (Böhler)
- Cromo 9 V (Thyssen)

The use of other welding filler material is only allowed after prior agreement with the purchaser.

On each casting, weld hardness shall be checked random wise and documented accordingly. Values of max. 350 HV are allowed.

**5.0 HEAT TREATMENT**

The hardening shall be uniform over the whole casting. The hardening temperature shall be

स्वत्वाधिकार एवं गोपनीय  
 इस प्रलेख में दी गई सूचना भारत हेवी इलेक्ट्रिकल्स की संपत्ति है इसका प्रत्यक्ष एवं अप्रत्यक्ष रूप से किसी भी तरह प्रयोग, जो कि कंपनी के हित में हानिकारक हो न किया जाए।

हस्ताक्षर एवं दिनांक  
 SIGN & DATE  
 दिनांक एवं हस्ताक्षर  
 SIGNATURE & DATE  
 माली सूची संख्या  
 INVENTORY NO.  
 P-4088  
 06.01.10

TSX	B. CHAUDHARY	(B) 12/01/10		नाम NAME	दिनांक एवं हस्ताक्षर SIGNATURE & DATE
IPSC	VK Chauhan	12/1/10	अनुवादक TRANSLATED BY		
STE	R.C. Kulkarni	12/1/10	निर्माणकर्ता WORKED BY	SUJEET KUMAR	12/1/10
QAX	NK Manwani	12/1/10	जांचकर्ता CHECKED BY	TSG	12/1/10
सहमत विभाग AGREED DEPTT	नाम NAME	दिनांक एवं हस्ताक्षर DATE & SIGNATURE	पर्यवेक्षणकर्ता SUPERVISED BY	JP MEENA	12/1/10
Rev01			स्वीकृति APPROVED :	संस्थान मानक समिति PLANT STANDARDS COMMITTEE	
			निर्माण PREPARED :	माली ISSUED :	दिनांक DATE :
			MTE	STANDARDS DIVISION	04/12/09

दिनांक एवं हस्ताक्षर SIGN & DATE		<p style="text-align: center;"><b>संस्थान क्रय विनिर्देश (डीप - हरिद्वार)</b></p> <p style="text-align: center;"><b>PLANT PURCHASE SPECIFICATION</b></p> <p style="text-align: center;">(HEEP - HARIDWAR)</p>	<p style="text-align: right;"><b>HW 19683</b></p> <p style="text-align: right;">पृष्ठ का Page 2 of 2</p>										
सामग्री सूची संख्या को INVENTORY NO.	SUPERSEDES INVENTORY NO.	<p>between 1040°C and 1070°C and the tempering temperature between 730°C and 750°C.</p> <p><b>Recommendation:</b></p> <p>To achieve the mechanical properties, following quality heat treatment has proven to be advantageous:</p> <p>Hardening temperature 1050 °C, holding time corresponding to the wall thickness, cooling by circulated air to &lt; 90°C to ensure a martensitic transformation of the whole cross-section.</p> <p>Tempering temperature 730°C, for a minimum of 12 hours, holding time corresponding to the wall thickness, cooling in furnace down to 300°C, then calm air.</p> <p>If the supplier carries out a rough-machining, the casting has to be stress relieved before delivery. The stress relieving temperature should not be more than the actually applied annealing temperature of the casting. The cooling rate for the stress relieving should be ≤30°C/hr down to ≤ 300°C.</p> <p>The stress relieving after rough machining can be dropped, if production welding followed by stress relieving is carried out after rough machining.</p> <p>Total holding time of all heat treatment performed (tempering and stress relieving) after hardening shall not exceed 40 hours at ≥ 730°C. If many heating cycles are necessary, the temperature before last heating can be reduced to 710°C.</p>											
COPYRIGHT AND CONFIDENTIAL The information on this document is the property of Bharti Heavy Electricals Limited. It must not be used directly or indirectly in any way detrimental to the interest of the company	<p><b>6.0 MECHANICAL PROPERTIES</b></p> <p>The mechanical properties of each casting shall be determined on attached samples in the delivery condition. The following properties shall be achieved at room temperature:</p> <table style="margin-left: 40px;"> <tr> <td>0.2% PS</td> <td>≥ 500 N/mm<sup>2</sup></td> </tr> <tr> <td>UTS</td> <td>630 - 750 N/mm<sup>2</sup></td> </tr> <tr> <td>%El (l=5d)</td> <td>≥ 16%</td> </tr> <tr> <td>%Ra</td> <td>≥ 40%</td> </tr> <tr> <td>Impact</td> <td>≥ 35 J *</td> </tr> </table> <p>* Average of 3 Charpy-V-notch specimens, where the smallest value shall be at least 30 J.</p>			0.2% PS	≥ 500 N/mm <sup>2</sup>	UTS	630 - 750 N/mm <sup>2</sup>	%El (l=5d)	≥ 16%	%Ra	≥ 40%	Impact	≥ 35 J *
0.2% PS	≥ 500 N/mm <sup>2</sup>												
UTS	630 - 750 N/mm <sup>2</sup>												
%El (l=5d)	≥ 16%												
%Ra	≥ 40%												
Impact	≥ 35 J *												
स्वत्वाधिकार एवं गोपनीय इस प्रस्ताव में दी गई सूचना भारत हेवी इलेक्ट्रिकल्स की संपत्ति है इसका प्रस्ताव एवं आलस्य रूप से किसी भी तरह प्रयोग, जो कि कंपनी के हित में हानिकारक हो न किया जाए।													
हस्ताक्षर एवं दिनांक SIGN & DATE	<p style="text-align: center;">12/11/2010</p>												
सामग्री सूची संख्या INVENTORY NO. P-4088	Rev 01	निर्माणकर्ता WORKED BY SUJEET	सुजीत सुजेत 6/1/10	जांचकर्ता CHECKED BY TSG 6/1/10									



**ANNEXURE- 3**

**COMPLIANCE SHEET FOR TECHNICAL/COMMERCIAL TERMS AND CONDITIONS FOR TWO PART TENDER**

**PLEASE FILL THIS ANNEXURE & ATTACH WITH YOUR TECHNO-COMMERCIAL BID.**

You are requested to kindly confirm /clarify the following:-

<b>S.No.</b>	<b>Description</b>	<b>Your Confirmation</b>
1.	Vendor to confirm that they meet each & every clause of our Specifications/Drawings.	
2.	If “No” to serial number 1, vendor to specify each deviated clause & submit in a separate sheet.	
3.	Vendor to list out on a separate sheet any activity which is outsourced. Please furnish details of out sourced vendor.	
4.	Validity: confirm that validity of the offer shall be 90 days from the date of tender opening	
5.	Confirm that un-priced part of price bid is enclosed with technical commercial offer.	
6.	Confirm that prices have been quoted on CIF basis (For Foreign vendors)	
7.	Confirm that Loading Port has been mentioned.	
8.	Confirm that prices have been quoted on FOR BHEL Haridwar basis. (For Indigenous vendor)	
9.	Confirm that prices shall be firm and fixed throughout delivery period.	
10.	Confirm that preferably payment term shall be “100% payment after receipt and acceptance of material”.	
11.	LD Penalty shall be applicable at the rate of ½ % (half percent) per week or part thereof subject to a maximum of 10% of the value of unexecuted portion of the order. In case of any variation in LD penalty, your prices shall be loaded to the extend LD penalty not accepted by you.	
12.	Confirm that all test certificates / Guarantee certificates to be submitted as per BHEL specification. in TRIPLICATE along with dispatch documents	
13.	Right of acceptance – BHEL reserves the right to reject any or all quotations without assigning any reasons thereof. BHEL also reserves the right to increase or decrease the tendered quantities. Vendors should be prepared to accept order for reduced quantities without any extra charges. Vendor should also be prepared for giving discount in case of increase in quantity.	
14.	Confirm specifically that material shall be supplied as per tender documents.	
15.	No grace period in delivery is acceptable. Please quote delivery accordingly.	
16.	Ink signed order acceptance shall be furnished within 15 days of order placement.	
17.	Confirm if there is Indian agency commission included in your price.	
18.	Please confirm your acceptance for Reverse Auctioning of these items.	
19.	In case of PO (if any), Invoices against goods and services have to be submitted immediately after supply of goods and services but not later than 30 days from the invoice date. In case of any delay, consequential losses like loss of input credit and non-availability of concessional forms etc., shall be to the vendor’s account (For Indigenous vendor). Kindly confirm.	
20.	‘In case of delays in supplies / defective supplies or nonfulfillment of any other terms and conditions given in Purchase Order the purchaser may cancel the Purchase Order in full or part thereof, and may also make the purchase of such material from elsewhere / alternative source at the risk and cost of the supplier.’ Kindly confirm.	

ANNEXURE - 6

**NON-DISCLOSURE AND PROPRIETARY INFORMATION AGREEMENT**

BETWEEN

\_\_\_\_\_ (Name of the Vendor), having its registered offices in \_\_\_\_\_ (Address of Vendor), registered under the no. of the Companies' register of \_\_\_\_\_ (Name of Place and Country), capital stock of \_\_\_\_\_ (Value), with a place of business in \_\_\_\_\_ (Name of Place and Country) (hereinafter referred to as " \_\_\_\_\_ (Name of Vendor)");

AND

**Bharat Heavy Electricals Ltd** a company incorporated under the Indian Companies Act 1956 having its registered offices at BHEL House, Siri Fort, New Delhi -110 049 and having one of its works at Heavy Electrical Equipment Plant, Ranipur, Haridwar-249403 (Uttarakhand), India registered under the No. 4281 of 1964-65 of the companies register of Delhi, capital stock of Rs 4895.2 million with a place of registered office in New Delhi (hereinafter referred to as "BHEL") hereinafter also referred to individually as "the Party" or collectively as "the Parties".

**BACKGROUND**

This Agreement sets forth the rights and obligations of the Parties with respect to the use, handling, protection and safeguarding of Proprietary Information that is disclosed by and between the Parties.

**WHEREAS**

A) the Parties wish to pursue exploratory discussions concerning a possible collaboration between them in relation to the Program defined in Exhibit 1;

B) during the ensuing discussions and negotiations it may occur that either Party discloses to the other technical, financial or business information of a proprietary or confidential nature, which the Parties intend to protect against, making it available, by any means to any third person, and other unauthorized use and/or further disclosure by the recipient, in accordance with the terms and conditions set forth herein;

**NOW, THEREFORE,** the Parties have agreed as follows:

1. The term “Proprietary Information” shall mean any information or data of whatsoever kind of a confidential or proprietary nature, including but not limited to, commercial information, know how and technical information in the form of designs, drawings, concepts, requirements, specifications, software, interfaces, components, processes, or the like, that have been or will be disclosed by either Party to the other pursuant to this Agreement, either in writing, orally or other form, which is designated as “Proprietary” or “Confidential” by the disclosing Party by means of formal declaration or an appropriate stamp, legend or any other written or orally notice .
2. Proprietary Information may be conveyed, without limitation, through any written or printed documents, samples, models, electronic form on disk, tape, other storage media or any other means of disclosing such Proprietary Information that either Party may elect to use during the life of this Agreement, but if an originating Party originally discloses information orally or visually, the receiving Party will protect such information as Proprietary Information to the extent that the originating Party :
  - identifies the Information as Proprietary at the time of original disclosure,
  - summarizes the Proprietary Information in writing .

Information stored in electronic form on disk, tape, other storage media will be adequately marked if a proprietary legend displays when the information originally runs on a computer system and when the information is printed from its data file.

Proprietary Information also includes any information which can be obtained by examination, testing or analysis of any hardware or material substance or any component part of such hardware or material substance provided by the Disclosing Party even though the requirements in Clause 1 for marking and designation have not been fulfilled.

3. Each Party, to the extent of its rights to do so, shall disclose to the other only the Proprietary Information which the disclosing Party deems appropriate to fulfil the objectives of this Agreement. The Parties hereby represent that the disclosure of Proprietary Information by and between themselves shall be made in compliance with, and subject to the laws and regulations of the Disclosing Party's country.
  
4. The receiving Party hereby agrees and covenants that, from the effective date of this Agreement until the expiry date as per article 11 and the following period as per article 12, the Proprietary Information that either Party receives from the other shall:
  - a) be protected and kept in strict confidence by the receiving Party which must use the same degree of care it uses to protect its own confidential information and in no case less than a reasonable care;
  
  - b) be only disclosed to and used by those persons within the receiving Party's organization or that of its parent or controlled companies who have a need to know and solely for the purposes specified in this Agreement, and be treated by such persons or entities with the same degree of care and subject to the same restrictions;
  
  - c) to procure that each third party to whom Proprietary Information is disclosed under this Agreement is made aware of the provisions of this Agreement prior to such disclosure to it and that each such third party is

bound by obligations of confidentiality which are no less onerous than those contained in this Agreement;

- d) neither be disclosed nor caused to be disclosed or made available, either directly or indirectly, to any third Party or persons other than those mentioned in subparagraph b) above or other persons upon which both of the contractual Parties shall agree in an amendment to this Agreement;
- e) not to copy, reproduce or reduce to writing any part of such Proprietary Information except as may be reasonably necessary for the purpose referred to in the Recitals of this Agreement

PROVIDED THAT the Receiving Party shall be entitled to make any disclosure required by court order or government or regulatory requirement of the Disclosing Party's Proprietary Information subject to notifying the Disclosing Party as soon as possible of such requirement

- 5. Any Proprietary Information and copies thereof disclosed by either Party to the other shall remain the property of the disclosing Party and shall be immediately returned or destroyed by the receiving Party upon request.
- 6. The receiving Party shall have no obligations or restrictions with respect to any Proprietary Information for which the receiving Party can prove that:
  - a) is in or which comes into the public domain otherwise than as a result of a breach of this Agreement by any person to whom a disclosure of Proprietary Information is made as permitted under this Agreement or of any other duty of confidentiality relating to the Proprietary Information of which the Receiving Party has knowledge; or
  - b) it has been in its possession without restriction at the time of the disclosure, as evidenced by written documentation in its files; or
  - c) it has been lawfully received from a third Party without breach of this Agreement; or

- d) it has been or is published without violation of this Agreement; or
  - e) it has been independently developed in good faith by employees of the receiving Party who did not have access to the Proprietary Information; or
  - f) it has not been properly declared, designated or confirmed as Proprietary or Confidential; or
  - g) the protection period has expired according to articles 11 and 12 of this Agreement.
7. With respect to any exchange of Proprietary Information which may occur as a result of this Agreement, it is expressly understood and agreed that the persons listed in Exhibit 2 shall, on behalf of the respective Parties, be the exclusive individuals authorized to receive from and transmit to the other Party Proprietary Information under this Agreement. Each Party may replace at any time its respective authorized individuals identified in such Exhibit 2, within its own organization. Any such new designation by a Party shall be made by written notice to the other at the address indicated in such Exhibit 2.
8. Any Proprietary Information which is identified as "Classified Information", or whose export is subject to an export license, shall be identified as such by the disclosing Party at the time of disclosure and the disclosure, protection, use and handling thereof, shall remain subject to the security procedures and restrictions imposed by the disclosing Party's Government.
9. The disclosure of Proprietary Information under this Agreement by either Party to the other shall not be construed as granting to the receiving Party any right, whether express or implied by licence or otherwise, on the matters, inventions or discoveries to which such information pertains, or as granting any trademark, patents, copyrights, trade secret right or other form of intellectual property right.

10. Nothing in this Agreement may be construed as an obligation of either Party to disclose any Proprietary Information to the other, or to enter into any subsequent contractual relationship with such other Party.
11. This Agreement covers the exchange of Proprietary Information which may be made by either Party to the other until ten years from signing of the agreement or any extension thereto which may be agreed upon by the Parties in writing. Proprietary information relevant to the Program detailed in Exhibit 1, already made available to the other contractual Party before the effective date, shall also be protected under this Agreement.

It is understood by the parties that, prior to disclosure, the Disclosing Party shall have obtained any government authorisation needed for the export of the Proprietary Information

12. The expiry of the period contemplated in Article 11 of this Agreement shall not relieve the receiving Party from complying with the obligations imposed by Article 4 here above with respect to the use and protection of the Proprietary Information, received prior the date of such expiry, for a period of ten (10) years after such expiry.
13. The Parties are independent contractors. Each will bear all costs and expenses in connection with this Agreement. This Agreement is intended to facilitate only the exchange of Proprietary Information and is not intended to be, and shall not be construed to create a teaming agreement, joint venture, association, partnership, or other business organisation or agency arrangement and no Party shall have the authority to bind the other without the other Party's separate prior written agreement .
14. This Agreement shall be governed by and shall be interpreted in accordance with the substantive federal laws of Switzerland excluding it's choice of law rules.

Irrespective of the foregoing each Party shall remain bound by the provisions of its own national laws and regulations with respect to the transfer or use of Classified Information or information whose export is subject to an export license.

15. All disputes among the Parties, in connection with or arising out of the existence, validity, construction, performance and termination of this Agreement (or any terms thereof), which the Parties are unable to resolve among themselves, shall be finally settled by an Arbitration. The Arbitration shall be held in Geneva (CH) in English language, in accordance with the rules of the ICC – International Chamber of Commerce by three arbitrators appointed in accordance with said rules.
16. The foregoing constitutes the entire Agreement among the Parties with respect to the subject matter hereof and supersedes and cancels all prior representations, negotiations, commitments, undertakings, communications, either oral or written, acceptances, understandings and agreements among the Parties with respect to or in connection with any of the matters to which such Agreement applies or refers.
17. Notices to \_\_\_\_\_ (**Name of Vendor**) shall be made at the following address:

**(Complete Address of Vendor)**

Attention: Mr. \_\_\_\_\_ (**Name of the Authorised Person of Vendor**)

Notices to BHEL shall be made at the following address:

BHARAT HEAVY ELECTRICALS LIMITED,

HEAVY ELECTRICAL EQUIPMENT PLANT,

Ranipur, Haridwar-249403 (Uttarakhand), India

Attention: Shri B.M.Bansal, General Manager- Materials Management

18. The effective date of this Agreement shall be the date of the last signature appearing herein.

**IN WITNESS WHEREOF**, each of the Parties has caused this Agreement, to be executed by its duly authorized officer.

Date :

Signed for and on behalf of

Signed for and on behalf of

**(Name of Vendor)**

BHEL

By:

By:

Title:

Title:

Signature:

Signature:

**EXHIBIT 1**

to the

**NON-DISCLOSURE AGREEMENT**

between

\_\_\_\_\_ **(Name of Vendor)**

and

**BHARAT HEAVY ELECTRICALS LIMITED**

dated:

\_\_\_\_\_

The Non Disclosure Agreement covers the exchange of Proprietary Information which may occur during the discussions and negotiations in view of a possible cooperation between the Parties in the following programs:

-Description of Material or Services for which the order is placed

\_\_\_\_\_ **(Name of Vendor)** list of products that require an exchange of Proprietary Information which may be occur during the discussions and negotiations in view of a possible cooperation for the above programs :

**Certificate by Chartered Accountant on letter head**

This is to Certify that M/S .....  
(hereinafter referred to as 'company') having its registered office at .....  
is registered under MSMED Act 2006, (Entrepreneur  
Memorandum No (Part-II) ..... dtd:.....  
Category: ..... (Micro/Small). (Copy enclosed).

Further verified from the Books of Accounts that the investment of the company as per the latest audited financial year ..... as per MSMED Act 2006 is as follows:

1. **For Manufacturing Enterprises:** Investment in plant and machinery (i.e. original cost excluding land and building and the items specified by the Ministry of Small Scale Industries vide its notification No.S.O.1722(E) dated October 5, 2006 :  
Rs.....Lacs
2. **For Service Enterprises:** Investment in equipment (original cost excluding land and building and furniture, fittings and other items not directly related to the service rendered or as may be notified under the MSMED Act, 2006:  
Rs.....Lacs

**(Strike off whichever is not applicable)**

The above investment of Rs.....Lacs is within permissible limit of Rs.....Lacs for .....Micro / Small (Strike off which is not applicable) Category under MSMED Act 2006.

Or

The company has been graduated from its original category (Micro/ Small) (Strike off which is not applicable) and the date of graduation of such enterprise from its original category is ..... (dd/mm/yyyy) which is within the period of 3 years from the date of graduation of such enterprise from its original category as notified vide S.O. No. 3322(E) dated 01.11.2013 published in the gazette notification dated 04.11.2013 by Ministry of MSME.

Date:



(Signature)

Name -

Membership number -

Seal of Chartered Accountant