



# भारत हेवी इलेक्ट्रिकल्स लिमिटेड

Bharat Heavy Electricals Limited

Tiruchirappalli - 620 014

Phone: 0431 - 2571539, 1573

E-mail: spswain@bheltry.co.in

Website: www.bhel.com

WORKS CONTRACTS MANAGEMENT

Tender No: WCM / 15 / 8013E

Dt: 04.03.2016

## NOTICE INVITING TENDER (NIT)

### FOR

### EDGE PREPARATION OF NOZZLES FOR 2 STEAM GENERATORS AT BHEL TRICHY-14

Sealed Tenders are hereby invited from experienced, reliable, resourceful, financially sound Works Contractors having Manpower and other resources of their own for "EDGE PREPARATION OF NOZZLES FOR 2 STEAM GENERATORS AT BHEL TRICHY-14".

**The bidders are advised to go through the terms & conditions and Tender schedules enclosed carefully before submitting their quotations.**

**Last Date / Time for receipt of Tender : 21.03.2016 / 10.30 AM**  
**Date / Time of opening : 21.03.2016 / 10.35 AM**

The bidders may contact Engineer / WCM (0431-2571539, 1573) (OR) DGM / WCM (0431-2574695) (OR) SDGM / WCM (0431-2577785, M/s Bharat Heavy Electricals Limited, Tiruchirappalli - 620014, Email: spswain@bheltry.co.in for any clarification required in this regard.

The Tender enquiry comprises the following documents:-

- |  |   |                  |
|--|---|------------------|
| <b>(1) This Covering letter of NIT</b>     | - | WCM / 15 / 8013E |
| <b>(2) Techno Commercial Bid</b>           |   |                  |
| (a) Special Instructions                   | - | Annexure-I       |
| (b) Specific Guidelines                    | - | Annexure-II      |
| (c) Special Conditions of the Contract     | - | Annexure-III     |
| (d) General Terms & Conditions of Contract | - | Annexure-IV      |
| (e) Safety Conditions                      | - | Annexure-V       |
| (f) Operational Control Procedures (OCP)   | - | Annexure-VI      |
| (g) Techno Commercial Bid                  | - | Annexure-VII     |
| (h) Declaration by bidder                  | - | Annexure-VIII    |
| <b>(3) Price Bid</b>                       |   |                  |
| (a) Price Bid                              | - | Annexure-IX      |

**This is only request for an offer and not a Contract.**

**PROCEDURE TO SUBMIT OFFERS / TENDERS**

Sealed Tenders in the BHEL's proforma enclosed shall be submitted in the following manner:  
**The bids shall be submitted in two parts namely (i) Techno- Commercial Bid & (ii) Price Bid.**

**EMD:-**

The bidder shall submit EMD of ₹ 20,000/- (₹ twenty thousand only) along with the Tender by way of Demand Draft drawn in favour of Bharat Heavy Electricals Limited, Trichy-14 payable at Trichy. (Or) one time EMD certificate issued by competent authority of BHEL Trichy -14. EMD exemption certificate (such as NSIC and MSE certificate) will be accepted. EMD in the form of Fixed Deposit and Bank Guarantee will be rejected.

The EMD shall be submitted in a separate sealed cover super scribing name of the bidder and "**EDGE PREPARATION OF NOZZLES FOR 2 STEAM GENERATORS AT BHEL TRICHY-14**",

Ref. Tender No. WCM / 15 / 8013E Dt: 04.03.2016

**Offer submitted without EMD will be summarily rejected.**

**Techno - Commercial Bid**

Techno Commercial Bid consists of the Annexure I to VIII, same shall be duly **signed & stamped** by the bidder in all the pages and submitted in full in token of the acceptance of the same.

**The Xerox copies of all the supporting documents enclosed should be duly signed & stamped.**

All the required documents shall be filed in the same serial as per the format/column of the "Technical and commercial Bid". **All the pages shall be serially numbered on the right hand side top corner.**

All the above documents shall be submitted in a separate sealed cover super scribing name of the bidder and "**EDGE PREPARATION OF NOZZLES FOR 2 STEAM GENERATORS AT BHEL TRICHY-14**",

**Ref. Tender No. WCM / 15 / 8013E Dt. 04.03.2016.** Offers without relevant documents as per eligibility criteria are liable to be rejected as per Tender conditions.

**Price Bid**

The price bids for shall be submitted in a separate sealed covers super scribing the cover "**EDGE PREPARATION OF NOZZLES FOR 2 STEAM GENERATORS AT BHEL TRICHY-14**", PRICE BID,

**Ref. Tender No. WCM / 15 / 8013E Dt. 04.03.2016**

**Submission of Price bid & Techno Commercial bid**

The bidder should put EMD (1<sup>st</sup> cover- as per clause 1.1), Techno Commercial Bid (2<sup>nd</sup> cover- as per above clause 1.2) and Price Bid (3<sup>rd</sup> cover- as per above clause 1.3). All Techno Commercial bid cover, EMD cover and Price Bid cover should be packed **in a single strong cover**, seal it and affix seal on the cover & subscribe the Tender subject, Tender number, date and address the same to ENGINEER / WCM, Bldg.No.53 (1<sup>st</sup> floor), M/s. Bharat Heavy Electricals Limited, Tiruchirappalli - 620014, duly super scribing Tender No., due date and time of opening.

In case you are not in a position to submit the offer, please send letter suitably specifying the reasons thereof.

Late and Delayed Tenders will be summarily rejected and under no circumstances it will be considered and accepted

for Bharat Heavy Electricals Ltd.

Sthitapragyan Swain  
ENGINEER / WCM  
Building 53 (1<sup>st</sup> floor)  
High Pressure Boiler Plant  
Tiruverumbur, Trichy-620014



# भारत हेवी इलेक्ट्रिकल्स लिमिटेड

Bharat Heavy Electricals Limited

Tiruchirappalli - 620 014

Phone: 0431 - 2571539, 1573

Email: spswain@bheltry.co.in

Website: www.bhel.com

WORKS CONTRACTS MANAGEMENT

## TECHNO COMMERCIAL BID

### ANNEXURE-I

TENDER NO: WCM / 15 / 8013E

Dt. 04.03.2016

### SPECIAL INSTRUCTIONS

The General terms & conditions of the Contract shall be applicable to the extent that the conditions therein do not supersede these special instructions given below:-

01. The Contractors who wish to participate have to **go through the Tender documents thoroughly** and plan well before quoting, to ensure that the Tender process is not aborted / vitiated, due to their reasons.
02. In case of an award of a Contract, if the Contractors fails to perform to the satisfaction of BHEL or fails to fulfill / comply with the performance evaluation criteria, the Security Deposit will not be refunded / BG will be encased.
03. The Contractor shall in respect of Personnel employed by him either directly or through sub-Contractors, comply with or cause to be complied with following statutory provisions and rules and in regard to all matters provided therein.
  - a. The Contract Labour (Regulation & Abolition) Act 1970 and the related Rules.
  - b. The minimum wages Act 1948 and the related rules
  - c. The payment of wages Act 1936 and the related rules.
  - d. The Factories Act 1948 and related Tamil Nadu Rules.
  - e. The Employees' Provident Fund & Miscellaneous provisions Act 1952.
  - f. The Employees State Insurance Act 1948.
  - g. Workmen Compensation Act 1923
  - h. Payment of Bonus Act 1965
  - i. Maternity Benefit Act, 1961
  - j. Payment of Gratuity Act, 1972
  - k. Inter-State Migrant Workmen (Regulation of Employment & Conditions of Service) Act, 1979
  - l. Equal Remuneration Act, 1976
  - m. Industrial Employment (Standing Order) Act, 1960 (In case of engaging 100 or more personnel)
  - n. The Industrial Disputes Act 1947

And any other law, or modifications to the above or to the rules made there under from time to time.

### IMPORTANT POINTS TO BE TAKEN CARE OF WHILE SUBMITTING OFFER.

- (a) Should a Tenderer find discrepancies or omissions in the Tender documents or should there any doubt as to their meaning, he should at once address the authority inviting the Tender, for clarification well before the due date, so as to submit his Tender in time. (No extension of time shall be given for submission of the Tender on any account)
- (b) Conditional and late Tenders, Tenders containing prima-facie absurd rates and amounts, Tenders which are incomplete or otherwise considered defective and Tenders not in accordance with the Tender conditions herein contained and the Tenders not in original **ARE LIABLE TO BE REJECTED**

Place:

Date:

Signature of the Tenderer  
with seal & full address

- (c) New vendors responding against BHEL web site / NIC / CPPP, may visit the area of work , if they want, to get to know the scope / work details and also area of work, prior to quoting.
- (d) All entries in the Tender documents should be in one ink. Erasures and overwriting are not permitted. All cancellations and insertions should be duly attested by the Tenderers concerned.
- (e) Rates should be quoted as per the Work / Rate schedule. Rates quoted in any other form will not be accepted and will be rejected.
- (f) Unit rates should be quoted in figures as well as in words for all the items shown in the attached schedule. Wherever there is a difference in the two, **the rates in words will be taken as final.**
- (g) The Tender must be signed separately and legibly by Partner / Director of the Firm or by the person holding the Power of Attorney on behalf of the Firm concerned. In the latter case, a copy of Power of Attorney, duly self-attested must accompany the proprietor or partner.
- (h) If a Tenderer deliberately gives wrong information in his Tender or creates conditions favorable for the acceptance of his Tender, the BHEL will REJECT SUCH TENDER AT ANY STAGE.
- (i) Words imparting singular number shall be deemed to include plural number and vice-versa where the context so requires.
- (j) Canvassing in any form in connection with Tenders is strictly prohibited and the Tenders submitted by the Contractors who resort to canvassing will be liable for rejection.
- (k) Should a Tenderer's or a Contractor's or in the case of a firm or company of Contractors / any of its shareholder's or shareholder's relative is employed in BHEL, the authority inviting the Tenders shall be informed in writing of this fact at the time of submission of the Tender, failing which the Tender may be disqualified, or if such fact subsequently comes to light, the Contract may be cancelled.
- (l) The Tender schedule and the Tender shall be deemed to form an integral part of the Contract to be entered into for this work.
- (m) Submission of Tenders by electronic media like e-mail, Internet, fax etc. followed by hard copy, is acceptable and will be at the sole risk of the Tenderer. The Tenders thus submitted will be final and binding on the Tenderer. BHEL will not be responsible for any consequences that may arise in this regard.
- (n) Late and Delayed Tenders will be summarily rejected and under no circumstances it will be considered and accepted.

#### **NOTE**

*BHEL may reject the bid or in case the contract has been awarded, then terminate the contract apart from taking any other suitable action under the contract or applicable legal provisions or BHEL guidelines including Guidelines for suspension of Business Dealings, without any liability for any compensation to the bidder if,*

*BHEL discovers at any time that any statement made by the bidder in the affidavit cum undertaking is false, fraudulent*

*or*

*Any document submitted by the bidder was fake and forged*

*or*

*If BHEL determines in the sole discretion that any statement was aimed at deliberately misleading BHEL with a view to ensure award of the subject contract to the bidder.*

Place:  
Date:

Signature of the Tenderer  
with seal & full address



# भारत हेवी इलेक्ट्रिकल्स लिमिटेड

Bharat Heavy Electricals Limited

Tiruchirappalli - 620 014.

Phone : 0431 - 2571539, 1573

Email: spswain@bheltry.co.in

Website: www.bhel.com

WORKS CONTRACTS MANAGEMENT

## TECHNO COMMERCIAL BID

## ANNEXURE-II

TENDER NO: WCM / 15 / 8013E

dt. 04.03.2016

### SPECIFIC GUIDELINES

#### 1. TENDER DUE DATE

##### 1.1 Last date / time for receipt of Tender

The completed Tenders shall reach on or before **10:30 Hrs** on **21.03.2016**. It is in their own interest to ensure that the Tenders reach in time. BHEL is not responsible for any postal delay. Tenders not submitted in the prescribed forms or incomplete Tenders are liable to be rejected.

##### 1.2 Date / time for opening of Tender

1.2.1 Sealed covers so received will be opened at Bldg. No.53, 1<sup>st</sup> Floor, Works Contract Management, BHEL, Tiruchirappalli on the same day i.e., on **21.03.2016 at 10:35 Hrs** in the presence of the Bidders or their Authorised Representatives who may choose to witness the same. The Techno Commercial bids only will be opened.

1.2.2 Any bidders submitted tender beyond the due date/time mentioned above will not be considered for price evaluation.

1.2.3 The Price Bids of bidders, who have technically qualified will be open later. The date & time of price bid opening will be informed to the technically qualified Bidders.

##### 1.3 Witnessing the Tender opening.

1.3.1 The representative of the Bidder may choose to witness the Tender opening have to produce the Authorization Letter, as per the **enclosed proforma**, before opening of the Tender. The representatives without Authorization Letter in the prescribed format will not be allowed to participate in the Tender opening.

1.3.2 Only one representative from one bidder will be allowed to participate in the Tender opening.

#### 2. QUOTING

##### 2.1 Quoting best rate and the sanctity of the L1 status.

Quoting the lowest best rate is a must against this Tender. However, bidders are required to understand that the lowest rate offered by them or accepted by them, as the case may be, should be honoured throughout the period of the Contract.

#### 3 Participation.

**The Parties who have been suspended or black listed or issued with "Show Cause Notice" by BHEL Trichy-14 or any other BHEL Unit will not be allowed to participate in the Tender** and the bidder should declare the same in the Tender. Even during the course of evaluation / finalization of Tender if it is found that some of the parties are black listed / barred from business transactions / under business hold, BHEL will not consider them for further participation in the Tender.

#### 4 VALIDITY OF OFFERS:

The rates quoted shall be valid for acceptance for a minimum period of 120 days from the date of Tender opening. Withdrawal of Tender or increasing the rates during this validity period, BHEL will be entitled to forfeit the EMD paid.

Place:

Date:

Signature of the Tenderer  
with seal & full address

**5. EMD:-****5.1 EMD/SD BY THE BIDDER WILL BE FORFEITED, IF:-**

- 5.1.1 After opening the Tender, the Tenderer revokes his Tender within the validity period or increases his earlier quoted rates.
- 5.1.2 The Tenderer does not commence the work within the period as per LOI / Contract. In case the LOI / Contract is silent in this regard then within 15 days after award of Contract.
- 5.1.3 In case of an Award of a Contract and if the Contractor fails to perform or does not comply with the Performance Evaluation Criteria, the Security Deposit will not be refunded / Bank Guarantee encashed.
- 5.1.4 Security deposit shall not be refunded to the Contractor except in accordance with the terms of the Contract.

**6. SIGNING THE TENDER**

- 6.1 The Tender shall be signed by the Authorized Signatory Only. Authorized signatory shall be the person holding 'power of attorney' on behalf of the firm / company / bidder-concerned authorized / empowered to act on behalf for the specific purpose
- 6.2 Authorized signatory should have Power of Autonomy issued by MD or Board of Directors or authorized person for this purpose for quoting Tender and all procedures connected with, till finalization and execution of the Contract.
- 6.3 In case the Bidder is a Partnership Firm under Partnership Act, the Tender shall be signed by all the Partners of the firm or by the Managing Partner who have Signature and Seal of the Contractor authorized to do so or by a person holding the Power of Attorney on behalf of the Partnership Firm.
- 6.4 A copy of the Partnership Deed and / or a copy of the Power of Attorney, Self attested shall accompany the Proprietor or Partner of the Company.
- 6.5 BHEL will not be bound by any other Power of Attorney granted or the change in the composition of the firm made, subsequent to the execution of the Contract agreement. They may however recognize such Power of Attorney or change in status after obtaining legal advice and the cost involved in that connection shall be chargeable to the bidder concerned.

**7. METHOD OF EVALUATION OF PRICES****7.1 Priority / Ranking**

The sum of basic rates i.e. (Package) for works including all charges, incidentals etc., exclusive of Service tax will be the basis for deciding Tender priority (Deciding the L1 Bidder).

**8. QUANTITY, RATE FINALIZATION & DISTRIBUTION OF LOAD****8.1 Tender quantity**

The indicative total Tender quantity is enclosed in Annexure-IX (Price Bid). Since this is a rate Contract, this quantity may increase or decrease based on the actual requirement of BHEL. Hence there is no fixed quantity will be awarded to the Contractor.

**8.2 Rate Finalization**

- 8.2.1 Lowest prices received against BHEL Tenders need not be the acceptable to BHEL and in that case BHEL would not be considered the same for award of Contract. BHEL would negotiate or re-float the Tender opened if L1 price is not the lowest acceptable price to them inter-alia other reasons.
- 8.2.2 BHEL will finalize the rates through price bid opening. Hence Tenderers are requested to give their best prizes at the first instant itself.
- 8.2.3 In the event of the final L1 prices are not reasonable / acceptable to BHEL, BHEL also may resort to short closure of this open Tender.

**8.3 Number of Contractors required**

- 8.3.1 The contract will be awarded to one contractor based on the total value of the offer. BHEL required one single Contractor to complete the above subject scope of work.
- 8.3.2 If the lowest acceptable total value quoted by two or more contractors is same, the L1 will be decided on lot basis.

Place:  
Date:

Signature of the Tenderer  
with seal & full address

## 9. IMPORTANT INSTRUCTIONS

1. The contractor should remit the salary/wages of their workmen only through Bank, directly to the salary/savings account of the employee concerned. Wherever the number of contract workmen employed by the contractor is more than ten and the contract period is more than one month, monthly clearance will be given in respect of those contractors, only if the salary/wages to the workmen concerned has been remitted in the bank account of the workmen. The relevant Bank statement/proof for Bank payment should be produced along with PF and ESI challans every month.
2. The Contractor shall provide their employees with Personal protective Equipment such as Safety Shoes, Helmet etc. (whatever required) and shall comply all safety regulations under Factories Act. Contractor has to ensure proper use of these equipment.
3. No women workers are allowed to work before 8.00 AM and after 6.00 PM.
4. The Contractor has to deploy the personnel who has completed the age of 18 and not above 45 years of age.
5. Tenderers shall sign each and every page of Tender documents and affix seal for having accepted the conditions.
6. The Contractor should bring Contract person to BHEL premises at his / her own cost, risk and execute the work allotted to him in BHEL premises.
7. The Contractor will have to make payment to the Contract Personnel, as per minimum wages prescribed by the Government of Tamil Nadu from time to time and additional payment per month (over and above the minimum wage) as given below, any amendment to the government notification, from time to time will be applicable and become part and parcel of these conditions.

Unskilled	-----	₹ 3,200/-
Semiskilled	-----	₹ 3,700/-
Skilled	-----	₹ 4,100/-
8. The above additional wages & minimum wages will also attract PF, ESI, Bonus etc.
9. The Contractor should follow and comply with Minimum Wages, ESI, PF, Bonus, Group Insurance and other statutory regulations as stipulated in Factories Act and other applicable State / Central Governments' rules & regulations.
10. For engaging more than 20 employees, Contractor have to submit a valid labour license after award of contract. Failing to do so, bills will not be processed and will be released on submission of valid labour license.
11. All safety equipment's to the personal, safety rules & regulations are to be followed as per BHEL's Safety Rules & Regulations. Once Contractor shall read these, understand and implement accordingly during the course of work.
12. BHEL will no way be responsible for any loss of life or any injury caused to any of the Contractors or their crew while executing the above work at BHEL premises.
13. The Contractor or his / her crew should handle the work with utmost care the Contractor.
14. Contractor shall supervise the work carried out by his / her employees by providing one supervisor for every 20 personnel engaged by them.
15. Contractor shall ensure that the employees deployed in the premises of BHEL are physically and mentally fit and do not have any criminal record. Such personnel should possess requisite skill, proficiency, qualification, experience etc, to suit to the work requirement of BHEL.
16. Contractor shall maintain appropriate records of his / her employee's deployed carry out the job(s).
17. Contractor will be responsible for the good conduct of his / her employees. In case any misconduct / misbehavior by any employee, the Contractor will replace such employee(s) immediately.
18. Contractor will ensure that the job is executed through his / her employees on and under no circumstances; the Contractor will not deploy any casual employee to carry out the job nor shall sub Contract the job without prior written permission.
19. Contractor shall be solely responsible for non-payment / delayed payment of minimum contribution under EPF, MW, ESI & Bonus Act, etc including additional wage prescribed by BHEL.

Place:  
Date:

Signature of the Tenderer  
with seal & full address

20. The liability for any compensation on account of injury sustained by an employee of the Contractor will be exclusively that of the Contractor.
21. The proof of execution of work should be submitted along with bill (printed form with covering letter and proof for execution of work).
22. Contractor shall observe provisions of the Factories Act, 1948 in respect of working hours, holidays, rest intervals, leave and overtime to his / her employee. No work shall be done on Second / third shift, overtime, Sundays or on other declared holidays without proper permission.
23. The log-book for day-to-day work executed should be maintained by the Contractor and the signature should be obtained from the Authorized Executive (user agency) of BHEL daily. The User Agency will certify the utilization of the engaged personnel (Attendance) as per the Contract condition to enable WCM to forward the bill for payment to Accounts Department after verification.
24. The Contractor should maintain attendance register and 'Work Diary' ( log-book) containing the details of work executed by him from time to time on Shift / Daily basis and obtain the signature from official concerned (user agencies) nominated for this purpose for having executed for the work correctly and satisfactorily.
25. Necessary gate entry pass will be issued by BHEL Security Department for Contract employee based on your application duly forwarded by the Contract Executing Department and approved by HR / Welfare / Contract Cell on fulfillment of the Statutory Obligation by the Contractor.
26. In the event of termination of Contract for any reason whatsoever, the Contractor shall withdraw all his / her employees from the establishment of BHEL. In case, Contractor decides to terminate services of his / her employees, he should settle all terminal dues including retrenchment compensation.
27. The Quoted Rate in the Price Bid should be exclusive of Service Tax and inclusive of any other taxes levied or to be levied by State or Central Government. Such levies should be borne by the Contractor. Service Tax will be paid extra on production of documentary evidence.
28. The Service Tax has to be paid to the statutory authority by the Contractor and proof should be submitted to BHEL along with the next month bill.
29. Quotation should be valid for a period of 120 days from the date of Tender opening.
30. If after issue of LOI / Contract, Contractor fails to commence the work within 15 days or complete the work in total as per the terms & conditions of Tender and to the satisfaction to BHEL, EMD / SD deposited by the Contractor may be forfeited and Contractor may be barred from participation in all types of future Tenders and the decision of BHEL will be final in this regards.
31. Statutory deduction like IT etc. will be deducted from Contractor payment as required by Law.
32. Under no circumstances shall BHEL be liable to compensate for any loss or damage that may be caused to the machines by accidents or complications arising out of such contingencies like fire, theft, riots, strikes and terrorism damage whether inside or outside BHEL premises while being engaged.
33. In case BHEL be held liable for any loss, damage or compensation to third parties arising from or in relation to operations done by the Contractor Personnel, such loss, damage or compensation shall be paid by the Contractor to BHEL together with the costs incurred by BHEL on any legal proceedings pertaining thereto.
34. The Contractor is directly responsible for injuries / death of Contract personnel or any person employed by him as well as to the third party occupants or other users arising due to accident. At any point of time, BHEL will not be responsible for any loss/damage either to the personnel or to the machines.
35. Any damage to BHEL materials due to rough and faulty handling by the Contractor's personnel will have to be made good by the Contractor to BHEL. Similarly if any damage caused to BHEL equipment's / installation, property of third party in the course of work by the Contractor's person, the same shall be made good by the Contractor.
36. The personnel engaged under this Contract should not be permitted to stay inside BHEL complex after completing their day's work. It will be the responsibility of the Contractor to take the personnel out of BHEL Complex as soon as their day's work is over.

Place:  
Date:

Signature of the Tenderer  
with seal & full address

**PROFORMA (SAMPLE)**

**(ON BIDDER'S LETTER HEAD)**

---

REF:.....

DT:.....

**AUTHORIZATION LETTER FOR PARTICIPATING TENDER OPENING**

We, M/s.....  
(name of the Tenderer)

hereby authorizing ..... (name of the representative) to

participate in the Tender opening of BHEL Trichy **“Edge preparation of nozzles for 2 steam generators at BHEL Trichy-14”**

**Ref. Tender No. WCM / 15 / 8013E dt: 04.03.2016**

The representative's specimen signature is appended below & attested.

(Signature of the representative)

Place:  
Date:

Signature of the Tenderer  
with seal & full address



# भारत हेवी इलेक्ट्रिकल्स लिमिटेड

Bharat Heavy Electricals Limited

Tiruchirappalli - 620 014

Phone : 0431 - 2571539, 1573

Email: spswain@bheltry.co.in

Website: www.bhel.com

WORKS CONTRACTS MANAGEMENT

## TECHNO COMMERCIAL BID

ANNEXURE-III

TENDER NO: WCM / 15 / 8013E

dt. 04.03.2016

### SPECIAL CONDITIONS OF THE CONTRACT

#### 1 BHEL SCOPE OF WORK:

1. Removal of dummy covers by gas cutting from nozzles after hydro testing of steam generator (In each steam generators there are 7 nozzles of diameter ranging from 114 mm to 611mm).
2. Electricity will be provided free of cost for operation of vendor supplied machines

#### 2 CONTRACTOR'S SCOPE of work:-

1. After dummy cover removal by BHEL, Machining of gas cut surfaces and removal of HAZ (Heat Affected Zone) with maximum metal removal being 25 mm. It is to be done as per drawing no :- 3-ss of nozzles are to be carried out as per the standard specification given by BHEL the dimension of edge preparation have strict tolerance and also with double angle. Details of nozzles are as per drawing no :- 3-HE-170-02603 (attached).
2. The Contractor has to deploy adequate manpower and necessary machines with tools and equipment for completing the work as per the schedule given by BHEL.
3. Contractor has to provide required personal protective equipment to their workmen and supervisor at their own cost and shall comply with all safety regulations under Factories Act.

#### 3 TENURE OF CONTRACT

##### 3.1.1 Tenure

- 3.1.2 The Contract is valid up-till one year from the date of award of contract.

#### 4 TAXES AND DUTIES

- 4.1.1 While quoting their rates, the Bidders are advised to take into account the likely expenditure, taxes what so ever, etc., excluding Service Tax which are incidental for transit.
- 4.1.2 The rates agreed shall be inclusive of all charges such as Wages for crew member, other handling equipment, with consumables to complete the above scope of work, overhead and insurance charges and including all Taxes etc., except Service Tax. No extra claim whatsoever shall arise on any account over and above the accepted rates during the currency of Contract will be entertained.

#### 5 REGISTRATIONS AND LICENCING.

- 5.1 Every Contractor shall register his name with the HR Department of BHEL Trichy-14 before taking up the work awarded to him by giving the following information and getting a code Number.
  - (a) Name of the Contractor.
  - (b) Nature of Work.

Place:  
Date:

Signature of the Tenderer  
with seal & full address

- (c) Period of Work.
- (d) Number of maximum labour employed by him on anyone day.
- (e) License No. & Date (Applicable in case of Contractors employing 20 or more workers).
- (f) The labour should be enrolled with PF, ESI and enrolment No should be furnished on finalization of Contract.

- 5.2 The Contractor (Licensed or unlicensed) shall promptly furnish every information and document required by BHEL Authorities.
- 5.3 The Contractor employing 20 or more crew members shall obtain a license from the authorities (The Deputy Chief Inspector of Factories / Assistant Commissioner of Labour as the case may be). This license shall be amended and / or renewed wherever there is an increase in the crew members employed by him or in the event of Contract being extended or renewed. The Contractor shall inform the license number to the BHEL Management before taking up the work.

## **6 WAGES**

- 6.1 The Contractor shall pay wages to the crew members employed by him at the rate, which shall not be less than the minimum wages declared by Tamilnadu Government from time to time plus additional wages prescribed by BHEL.
- 6.2 The Contractor shall ensure the disbursement of wages in the presence of such authorized representatives from user agencies of BHEL Management.
- 6.3 A certificate of payment shall be furnished in duplicate by the Contractor to the In-charge of user agencies for each month.
- 6.4 The Contractor shall inform the BHEL Management every month the details of Contract labour engaged for each Contract in the following forms:-
- (A). Location.
  - (B). Serial Number.
  - (C). Period of Work.
  - (D). No. of Contract labour engaged during the month.
  - (E). No. of days worked.
  - (F). No. of Man – days worked.
  - (G). Wages paid to his workers.

The above statement shall be furnished to BHEL Management at the end of every month.

## **7. REGISTERS AND RECORDS**

- 7.2 The Contractor shall maintain necessary documents I Formats and Registers and submit returns as required under the Contract Labour (Regulation and Abolition) Act 1970 periodically to BHEL Management and to the Licensing Authority.
- 7.3 All registers and records shall be preserved in original for a period of three years all the registers, records and notice maintained under the Act and rules shall be produced on demand by inspector or any authority under The Act.

## **8. WORKING CONDITION**

- 8.1 The Contractor shall provide all safety devices and personal protective equipment to his employees at his own cost and shall ensure that his crew members wear / use such device or equipment provided to them while doing the work and there should not be any relaxation on this.
- 8.2 The Contractor shall ensure that his employees vacate the premises after shift is over.

## **9. NOTICES OF ACCIDENTS**

- 9.1 In the event of an accident the Contractor shall be required to fill injury report and submit to the Engineer In charge immediately and ensure compliance of ESI / Workmen's Compensation of accident as per the Act.
- 9.2 The Contractor shall get the Contract personnel engaged by him insured under workmen's compensation policy from General Insurance Corporation of India before actually starting the work of Contract. The Insurance Coverage should be for the entire period of Contract. The Contractor shall comply with the provisions of the Workmen's Compensation Act 1923. (This should be read in connection with the provisions of ESI Act.)

Place:  
Date:

Signature of the Tenderer  
with seal & full address

**10. COVERAGE UNDER THE ESI / PF ACT MISCELLANEOUS PROVISIONS ACT**

- 10.1 The Contractor shall ensure that all his personnel are covered under the Employee's State Insurance Act and produce to BHEL such Registration number/ Enrolment Number before executing the Contract work.
- 10.2 The Contractor shall regularly pay the amount by contribution i.e. employer's contribution as well as employee's contribution in pursuance of the above scheme as fixed from time to time.
- 10.3 The Contractor shall ensure that his contract personnel are covered the PF & miscellaneous provisions Act 1952 and accordingly produce to the BHEL Management the Registration / Enrollment number before awarding of Contract work.
- 10.4 The Contractor shall within seven days of the close of every month submit to BHEL a statement showing the amount of contribution payable / paid for employees engaged by him or through him and shall also furnish to BHEL such information, as Principal Employer is required to furnish under the provisions of the ESI Act PF as well as the schemes made there under to the authorities concerned.
- 10.5 Whenever any sum of money is found to be recoverable from or payable by the Contractor, the same shall be deducted from any sum that may be due or which at any time thereafter may become due to the Contractor under this Contract or under any other Contract or from his security deposit. In case the recoveries are not sufficient to satisfy the claims, the Contractor shall pay the balance thereof on demand. In case any recoveries are made under this clause from the security deposit, the contractor shall immediately thereafter pay such further sum as may be required to replenish the shortage caused by such recoveries in the amount of security deposit.
- 10.6 In case of non-compliance of the provisions of the Acts and in case BHEL having complied with the same BHEL will be entitled to recover the same from the Contractor / sub-Contractor.
- 10.7 The Contractor shall abide by all the labour and other laws applicable to Contract labour / worker under this Contract and shall at all-time keep BHEL Indemnified against all losses, claims, prosecutions under any law.
- 10.8 Non exercise of any of the powers or rights available under any law, shall not in any way operate as waiver thereof.

**11. COMMON TERMS AND CONDITIONS FOR WORKS CONTRACT RELEVANT TO SAFETY.**

- 11.1 All the Contract employees should be trained on Safety and certified by Safety / BHEL.
- 11.2 Use of cell phones and other mobile electronic devices (including hands-free devices) in the work spot in the BHEL premises is prohibited.
- 11.3 Contractor employees working on BHEL premises must wear appropriate personal protective equipment. Strict adherence to all required Personal Protective Equipment (Helmet, Safety Shoes and Goggles) are mandatory, specific PPE requirements will be based on job type or tasks performed.
- 11.4 Excessively loose-clothing, dhoti / Lungi are prohibited especially around rotating or moving equipment.
- 11.5 The Contractors work area should be kept clean and orderly, free of clutter and trash, so that work may proceed in a safe and orderly manner. Tools should be safely positioned during use and promptly put away when no longer required.
- 11.6 Fire-fighting, emergency shutdown devices, and life-saving equipment, should not be blocked by the Contractors and access to the path to this equipment should be maintained at all times.
- 11.7 Only approved equipment should be used in locations where flammable mixtures are present. A Hot Work Permit is required when open flames, or electric arcs are in the work area and while handling flammable materials.
- 11.8 Smoking is not allowed in work area.
- 11.9 BHEL operates under a comprehensive Emergency Response Plan. Contractor should be aware of the site Emergency Response Plan and communicate that plan to all their employees.
- 11.10 It is the responsibility of the Contractor to understand and use the appropriate Work Permits and to verify any permit requirements at the location. Contractor must make necessary arrangements

Place:  
Date:

Signature of the Tenderer  
with seal & full address

with their Representative to acquire appropriate authorization to perform those operations at the site.

- 11.11 Fall protection equipment should be worn when working two meters or more above an established working surface.
- 11.12 The minimum requirements for fall protection should be a full body harness, shock absorber, double locking snap hooks, and lanyard attached to a stationary support. Other fall protection systems (Roof top walk ladder, Duct ladder and safety Net) can be used with prior approval of the Safety dept. of the BHEL facility.
- 11.13 Examples of operations that require a Permit to Work may include but are not limited to:
- Hot Work.
  - Excavation and Trenching.
  - Confined Space Entry.
  - Electrical Work.
  - Working on Elevated Heights.
  - Pipeline work.
  - Roof Work.
  - Radiography.

## 12. SECURITY DEPOSIT:-

Security Deposit should be paid by the Contractor. Security Deposit shall be collected from the successful Tenderer as shown below:

Total Contract Value	Security Deposit Amount
Upto ₹ 10 lakhs	10 % of the Total Freight Value
Above ₹ 10 lakhs upto ₹ 50 lakhs	₹ 1 lakh + 7.5 % of the freight amount exceeding ₹ 10 lakhs
Above ₹ 50 lakhs	₹ 4 lakhs + 5 % of the amount exceeding ₹ 50 lakhs

The Security Deposit shall be collected before start of the Work.

(a) You may furnish the Security Deposit any one of the following forms:

- Cash (as permissible under the Income Tax Act).
- Pay Order, Demand Draft / Fixed Deposits / Bankers check or bank guarantee in favor of BHEL.
- Local cheques of scheduled banks, subject to realization.
- Securities available from Post Offices such as National Savings Certificates, Kisan Vikas Patras etc. (Certificates should be held in the name of Contractor furnishing the security and duly pledged in favour of BHEL and discharged on the back).
- Bank Guarantee from Scheduled Banks / Public Financial Institutions as defined in the Companies Act. The Bank Guarantee format should have the approval of BHEL and with minimum 15 months validity.
- Fixed Deposit Receipt issued by Scheduled Banks/ Public Financial Institutions as defined in the Companies Act. The FDR should be in the name of the Contractor, A/C BHEL, duly discharged on the back and with minimum 15 months validity.
- Security deposit can also be recovered at the rate of 10% from the running bills. However in such cases at least 50% of the Security Deposit should be collected (any of the above form) and the balance 50% may be recovered from the running bills.
- The security deposit shall not carry any interest.

(Note: Acceptance of Security Deposit against Sl. No. (4) and (6) above will be subject to hypothecation or endorsement on the document in favour of BHEL. However, BHEL will not be liable or responsible in any manner for the collection of interest or renewal of the documents or in any other matter connected therewith).

- 12.1 Security Deposit shall not be refunded to the Contractor except in accordance with the terms of the Contract.
- 12.2 All compensation or other sums of money payable by the Contractor to BHEL under the terms of this Contract or under any other Contract with BHEL may be deducted from the Security Deposit or realized by the sale of the securities or from the interest arising there from or from any sums
- 12.3 which may be due or may become due to the Contractor by BHEL and in the event of this Security Deposit being deducted by reason of such deductions or sale, as aforesaid, the

Place:  
Date:

Signature of the Tenderer  
with seal & full address

Contractor shall within 7 days thereafter, make good in cash or in securities endorsed as aforesaid, any sum by which the Security Deposit has been reduced.

### **13 REFUND OF SECURITY DEPOSIT**

- 13.1 The security deposit shall be refunded after successful completion of the Contract as per agreement and subject to deduction of any amount due to BHEL.
- 13.2 Contractor shall first have been paid the last and final bill and have rendered a "NO DEMAND CERTIFICATE" from the user agencies.
- 13.3 Security deposit shall not be refunded to the Contractor except in accordance with the terms of the Contract.

### **14 RISK PURCHASE**

- 14.1 In the event of any successful Tenderer's failure to fulfill any of the Tender / Contract obligations as per Contract / Agreement BHEL may entrust the job to alternate source and get it completed to meet BHEL requirement and additional expenditure, if any, including consequential cost viz., demurrage etc., will be fully recovered from the Tenderer Contractor who failed to complete the job in line with Contract.
- 14.2 The decision of BHEL with regard to the actual losses / consequential expenditures incurred by BHEL shall be final and binding on the Tenderer / Contractor.

### **15 SUBMISSION OF BILLS BY CONTRACTOR:-**

- 15.1 WCM is arranging this contract as a nodal agency. Execution of work, Bill Certification, Bill passing, Payment, Penalty, Contract closing etc., is the responsibility of end user
- 15.2 The bill should be submitted within a week after execution of work to the executing agencies.
- 15.3 At the time of bill submission the contractor have to submit the following Documents
- a. ESI, PF and service Tax remitted challans every month.
  - b. LOG Sheet & Wage Register dully certified by the end user

### **16 INDEMNITY:**

- 16.1 The Contractor shall have to indemnify BHEL against all claims for injury or damage to any person or property caused by his negligence or negligence of his employees whilst in BHEL premises / sites.
- 16.2 The Contractor shall indemnify the company against all payments by way of compensation or otherwise which the company may be called upon to make under the provisions of the applicable Acts to any Contract employee as aforesaid, and any cost incurred by the company in connection with any claim preferred by such Contract employee and or against all actions, claims and demands whatsoever in respect thereof or in respect of any loss, injury or damages whatsoever to any third person arising out of or occasioned by the negligent, imperfect or improper performance of this Contract by the Contractor, their employee servants or agents.
- 16.3 The Contractor approved and operating under the Tender, Works Contracts shall further indemnify BHEL against:-
- 16.3.1 Observance of Labour & Industrial Laws.
  - 16.3.2 All claims by way of compensation and all other types of unforeseen claims, which may arise in the course of Contract.
  - 16.3.3 Documentary compliance relating to freight billing.
  - 16.3.4 Indemnity shall cover the entire transit right after loading to the unloading at destination.

### **17 PAYMENT OF BILLS:-**

- 17.1 All payments to be made to the Contractor, shall be through NEFT (National Electronic Fund Transfer / RTGS (Real Time Gross Settlement) within reasonable time, say one month (or as mutually agreed), after receipt of the bill along with user agencies' acknowledgement.
- 17.2 Wherever applicable payments to be made to the Contractor, under this Contract shall also be by "CHEQUE" crossed "A/C PAYEE ONLY" within a reasonable time say one month (or as mutually agreed), after receipt of the bill along with user agencies acknowledgement.

Place:  
Date:

Signature of the Tenderer  
with seal & full address

**18 RIGHTS**

- 18.1 BHEL may enter into parallel Contract simultaneously with any number of Contractor as may be deemed fit at any time during the period of Contract in the Interest of the work for any or all the stations and for any or all the schedules.
- 18.2 In case of breach of any of the terms and conditions of the Contract, BHEL will entrust the work to any other Contractor at the risk and cost of the Contract and the Contractor shall be liable to pay the extra expenditure, damages, loss suffered on account of the cancellation of the Contract
- 18.3 All amounts including the losses / damages / penalties / compensations etc., resulting from non-compliance with the terms of Contract, payable by the Contractor to BHEL under the Terms of the Contract will be recovered from the outstanding payments to Contractor either under this Contract or any other Contracts or from Security Deposit or from both. In case this amount is insufficient for such recoveries, the Contractor shall make good the balance amount by actual payment. In addition BHEL, Trichy will recover the said amounts through its sister concerns, from the payments due to the Contractor in any of the units of BHEL located in any part of India.
- 18.4 The Contractor is not allowed to pass the responsibilities connected with the Contract to other agencies / Contractors, the Contractors shall not sublet or transfer the Contract or any part thereof, which tantamount to termination of the Contract and thereby attracting the penalty or forfeiture of security deposit.
- 18.5 The Contractor shall have no right to demand at any time during the currency of this Contract any minimum quantity of Work for this Contract.

**BHEL may verify / audit check by surprise visits at various locations of Works at their discretion and see whether the above requirements are complied with by the Contractor. In case the above requirements are not complied with, severe actions may be taken by BHEL on such Contractors, as deemed fit.**

**19. PROVISION FOR MSE**

20% of the tendered quantity is earmarked for MSE vendors in this tender (subjected to participation of MSE vendors). Out of 20% tenderer quantity reserved for MSE suppliers, 4% shall be earmarked MSE vendors owned by ST/SC entrepreneurs (subjected to participation of such MSE vendors). In case MSE vendor participating in the tender quotes within the price band of L1 + 15%, they will be allowed to supply the portion of requirement subject to acceptance of L1 price by MSE vendor. In-case of more than such MSE, the supply shall be share proportionally.

MSE Suppliers can avail the intended benefits only if they submit along with the offer, attested copies of either EM II certificate having deemed validity (five years from the date of acknowledgement in EM II) or valid NSIC certificate or EM II certificate along with attested copy of CA certificate (format will be provided on request to the tender issuing authority) (where deemed validity of EM II certificate of five years has expired) applicable for the relevant financial year (latest audited). Date to be reckoned for determining the deemed validity will be the date of technical bid opening. Non submission of such documents will lead to consideration of their bid at par with other bidders. No benefit shall applicable for this enquiry if any deficiency in the above required documents are not to submit before price bid opening.

Place:  
Date:

Signature of the Tenderer  
with seal & full address

ALL DIMENSIONS ARE IN MILLIMETERS

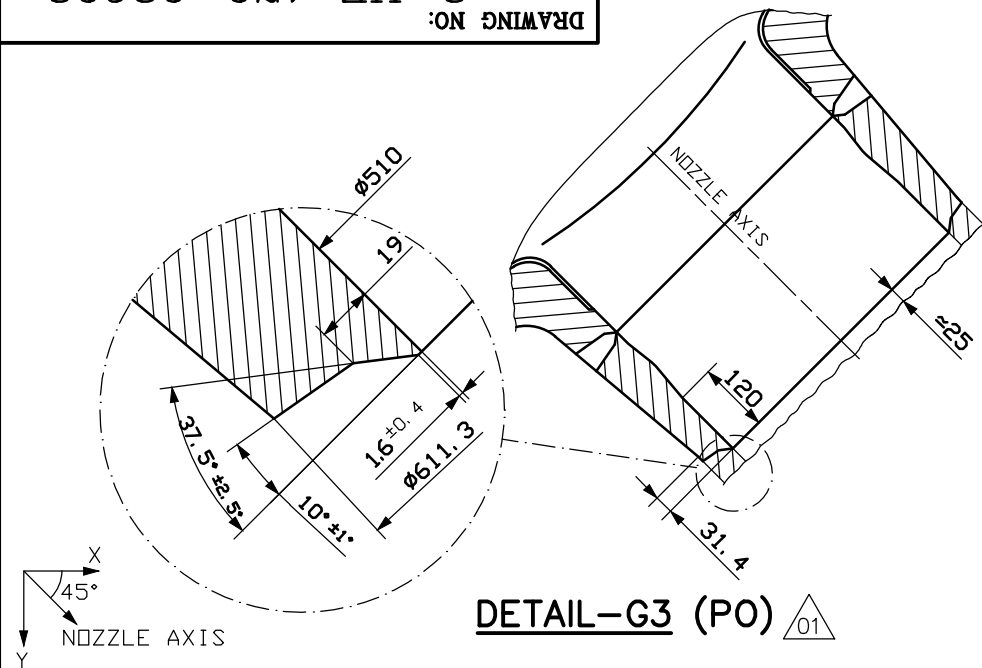

DETAIL-G3 (PO) 01

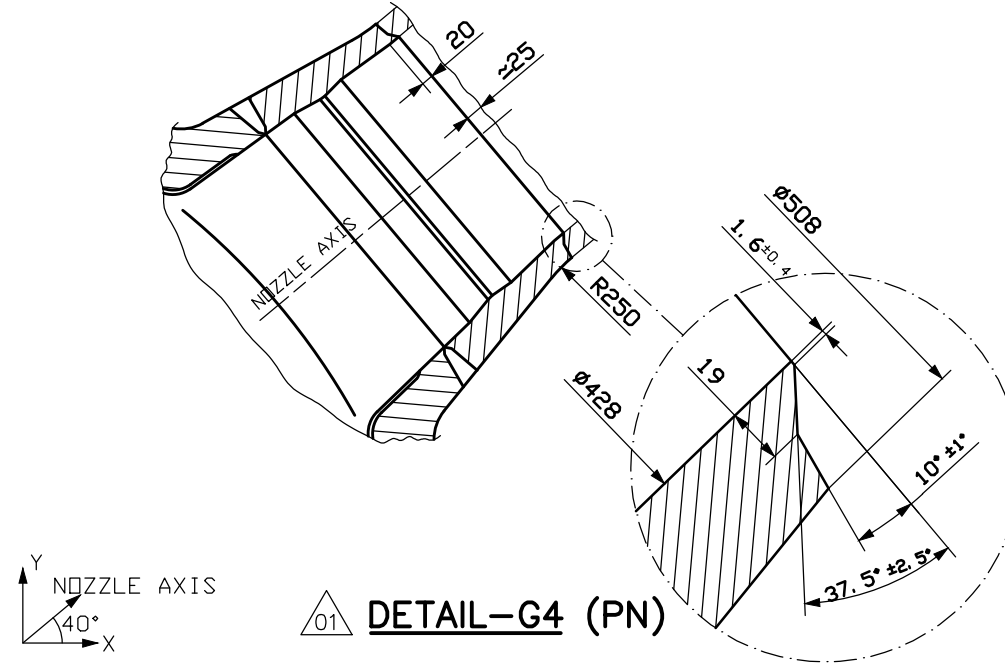

DETAIL-G4 (PN) 01

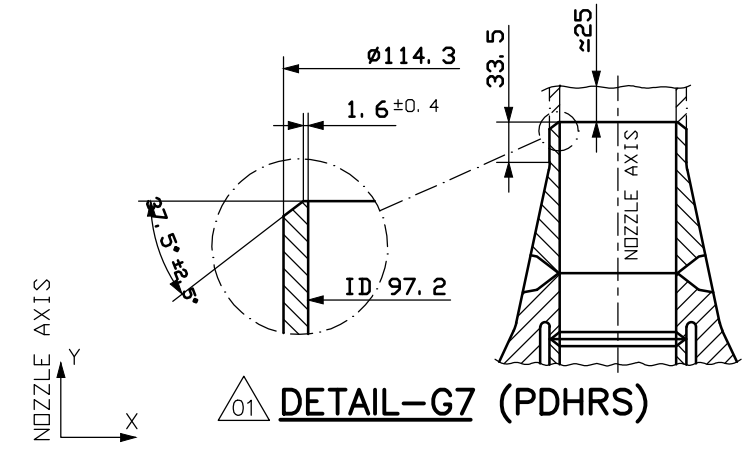

DETAIL-G7 (PDHRS) 01

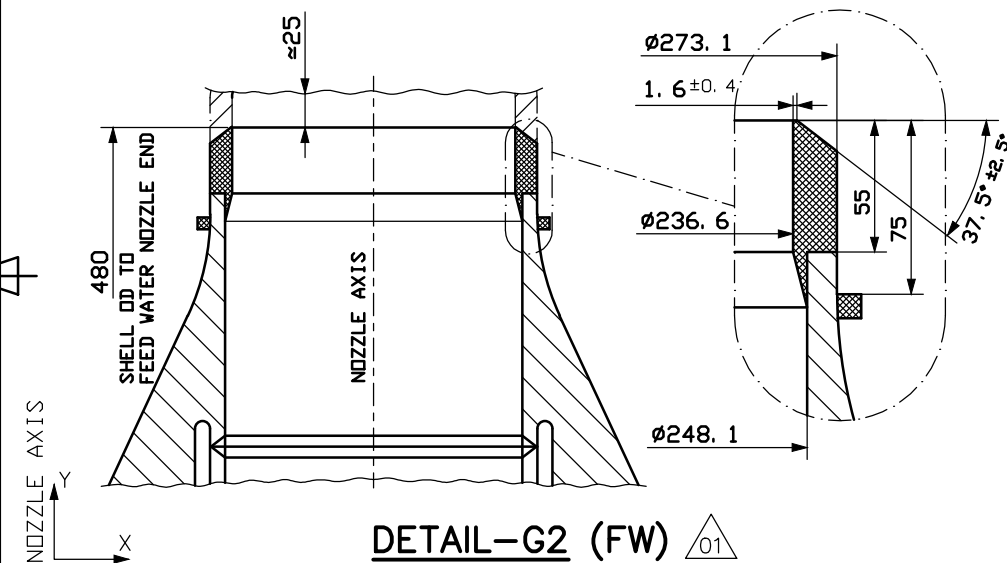

DETAIL-G2 (FW) 01

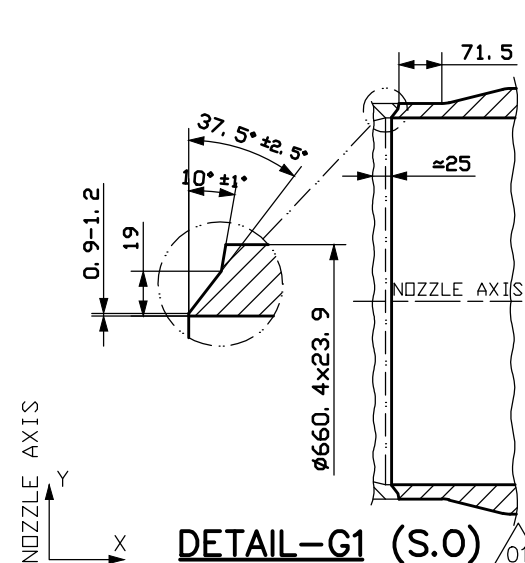

DETAIL-G1 (S.O) 01  
(1:10)

NOTES.

SL. Nos.	NOZZLE MARKS	DESCRIPTIONS	QTY. / S. G	MATERIAL	REMARKS
1	S. O	STEAM OUTLET NOZZLE	1	15Mo3	
2	F. W	FEED WATER NOZZLE	2	FERRITIC BUTTERING E-7018-1	
3	P. O	PRIMARY OUTLET NOZZLE	1	SA350GRLF2	
4	P. N	PRIMARY INLET NOZZLE	2	SA350GRLF2	
5	PDHRS	PDHRS NOZZLE	1	15Mo3	

**CAUTION:**  
THIS DRAWING SHOULD BE KEPT IN STRICT CONFIDENCE AND UNDER NO CIRCUMSTANCES BE MADE AVAILABLE TO OTHERS OR ALLOW TO MAKE USE OF THEM

CAUTION: The information on this document is the property of BHARAT HEAVY ELECTRICALS LTD. It must not be used directly or indirectly in any way detrimental to the interest of the company.

TYPE OF PRODUCT OR NAME OF CUSTOMER/PROJECT		700MWe S.G.						
		W.O. No.D131 TO D138-001-1						
 BHARAT HEAVY ELECTRICALS LTD. 05-229/D	Bharat Heavy Electricals Ltd		NAME	E. B	DATE	01.12.2015	NO. OF VAR	
	UNIT: HIGH PRESSURE BOILER PLANT		DRN		DATE	02.12.2015		
	TIRUCHIRAPALLI - 620014		CHD	RRV/NKK	DATE	04.12.2015		
DEPT	NC	GRADE OF UNTOL DIM	C/M/F	SCALE	WEIGHT (Kg)	REF TO ASSY / OLD DWG	ITEM NO	No OF ITEMS
CODE	150							
TITLE			CARD CODE	DRAWING NO :			REV	
NOZZLE E.P. DETAILS			U 01	3-HE-170-02603			01	

REV	DATE	ALTERED :
01	18.02.16	CHD&APPD : R. Rajam
HALF SECTIONAL VIEW CHANGED TO FULL SECTIONAL VIEW		



# भारत हेवी इलेक्ट्रिकल्स लिमिटेड

Bharat Heavy Electricals Limited

High Pressure Boiler Plant, Tiruchirappalli - 620 014.

Phone : 0431 - 2571539, 1573

Email: spswain@bheltry.co.in

Website: www.bhel.com

WORKS CONTRACTS MANAGEMENT

## TECHNO COMMERCIAL BID

ANNEXURE-IV

TENDER NO: WCM / 15 / 8013E

dt. 04.03.2016

### GENERAL TERMS & CONDITIONS OF THE CONTRACT

1. **DEFINITION :-** In these General Conditions of Contract, the following terms shall have the meaning hereby assigned to them, except where the context otherwise requires:-
  - 1.1. The "**Contract**" means, the documents forming the Tender and acceptance thereof, together with all the documents referred to therein including general and special conditions to Contract. All these documents as applicable taken together shall be deemed to form one Contract and shall be complementary to one another.
  - 1.2. The "**work**" means, the work described in the Tender documents in individual work-orders as may be issued from time to time to the Contractor by the Officer-In-charge within the power conferred upon him including all notified or additional items of works and obligations to be carried out as required for the performance of Contract.
  - 1.3. The "**Contractor**" means, the individual Firm or Company whether incorporated or not, undertaking the work and shall include the legal personal representatives of such individuals or the persons composing the firm or Company or the successors of the firm or company and the permitted assigns of such individual or firm or Company.
  - 1.4. "The **Officer-In charge**" means, the Officer deputed by the SDGM / WCM, to supervise the work or part of the work.
  - 1.5. "**Approved**" and "**Directed**" means, the approval or direction of SDGM / WCM, or person deputed by him for the particular purposes.
  - 1.6. "BHARAT HEAVY ELECTRICALS LIMITED" (herein after referred to as BHEL) shall mean the Board of Directors, Chairman, Executive Director, General Manager or other Administrative Officer of the said Company including SDGM / WCM authorized to invite Tenders and enter into Contract for works on behalf of the Company.
  - 1.7. The "**Contract sum**" means, the sum accepted or the sum calculated in accordance with the prices accepted in Tender and / or the Contract rates as payable to the Contractor for the execution of the work during the currency of the Contract.
  - 1.8. A "**week**" means, Seven Days, without regard to the number of hours worked or not worked in any day in that week.
  - 1.9. A "**day**" means, the day of 24 hours (TWENTY FOUR) irrespective of the number of hours worked or not worked in that day.
  - 1.10. A "**working day**" means, any day other than that prescribed by the NEGOTIABLE INSTRUMENTS ACT as being a Holiday, and consists of the number of hours of labour as commonly recognized by good employers in the trade in the district where the work is carried out or as laid down in the BHEL regulations.
2. **HEADING TO THE CONTRACT CONDITIONS:** - The heading to these conditions shall not affect the interpretations thereof.
3. **DEVIATIONS:-** The Contractor shall not carry out any work not covered by schedule except in pursuance of the written instructions of SDGM / WCM.,. No such work shall be valid unless the same has been specifically confirmed and accepted by BHEL in writing and incorporated in the Contract.

Place:  
Date:

Signature of the Tenderer  
with seal & full address

4. **ASSIGNMENT OF TRANSFER OF CONTRACT:-** The Contractor shall not without the prior written approval of the BHEL, assign or transfer the Contract or any part thereof, or any share, or interest thereon to any other persons. No sum of money which may become payable under the Contract shall be payable to any person, other than the Contractor unless the prior written approval of the BHEL to the assignment or transfer of such money is given.
5. **SUB-CONTRACT:-** The Contractor shall not sub-let any portion of the Contract without the prior written approval of the BHEL.
6. **COMPLIANCE TO REGULATIONS AND BY-LAWS:-** The Contractor shall confirm to the provisions of any statute relating to the work and regulations and Bye-Laws of any local authority. The Contractor shall be bound to give all notices required by statute regulations or By-Laws as aforesaid and to pay all fees and taxes payable to any authority in respect thereof.
7. **INCOME TAX:-**
- 7.1. Income shall be deducted at the applicable rate in respect of the service Contract including supply of labour for any work as follows:
- 7.2. Xerox copy of PAN card shall be submitted to Account Dept. along with original for verification.
- 7.3. TDS Certificate will be issued to vendors for each quarter ending as on 30th June, 30th Sept, 31st Dec and 31st Mar during the following quarter.
8. **SERVICE TAX:-**
- 8.1 Wherever service tax is liable to be paid by the Contractor, the Contractor shall register himself under the Service Tax Rules and a copy of Certificate of Registration shall be furnished to Account Dept.
- 8.2 After registration, the payment of Service Tax shall be effected by the Contractor to the Central Government monthly/quarterly based on the invoices raised before the due date of payment. The Service Tax Return also shall be submitted to the Government before the due date.
- 8.3 The invoice/bill in original duly signed by the Contractor claiming the payment for Service Tax shall clearly indicate the following:
- ❖ Continuous Serial no. & date of the bill
  - ❖ Cost of the service
  - ❖ Separately showing the Service Tax amount calculated at the applicable rate
  - ❖ PAN based Service Tax Registration No.
- 8.4 The Service Tax claimed in the bill will be paid to the Contractor based on the proof of payment of service tax to the Central Government for the previous month/quarter as the case may be.
9. **VALUE ADDED TAX (VAT):-** Wherever the service includes the supply of materials and claim is made for the payment of VAT, the original invoice duly signed by the Contractor clearly indicating the cost of materials, rate of VAT, VAT amount, TIN no. is to be submitted for payment and availing the VAT credit.
10. **ORDERS UNDER THE CONTRACT:-** All orders, notices etc. to be given under the Contract shall be in writing, type-script or printed and if sent by registered post to the address given in the Tender of the Contract, shall be deemed to have been served on the date, when in the ordinary course they would have been delivered to him. The Contractor shall carry out without delay all orders given to him.
11. **CONTRACTOR'S SUPERVISION:-**
- 11.1. The Contractor shall either himself supervise the execution of the Contract or shall appoint a competent agent acceptable to the SDGM / WCM., to act in his stead.
- 11.2. Orders given to the Contractor's agent shall be considered to have the same force as if they have been given to the Contractor himself.
- 11.3. The Contractor or his accredited agent shall attend when required without making any claim for doing so, either the office of the SDGM / WCM or the OFFICER-INCHARGE, to receive instructions.

Place:  
Date:

Signature of the Tenderer  
with seal & full address

- 11.4. The SDGM / WCM shall have full powers and without assigning any reason, require the Contractor to immediately cease to employ in connection with this Contract, any agent, servant or employee where continued employment is, in his opinion undesirable. The Contractor shall not be allowed any compensation on this account.
12. **LABOUR:-** The Contractor shall remain liable for the payment of all wages or other moneys to his work-people or employees under the payment of Wages Act 1936, Employees Liability Act. 1938, Workmen's Compensation Act 1923 or any other Act or enactment, relating thereto and rules framed, there under from time to time.
13. **PRECAUTIONS AGAINST RISK:-** The Contractor shall be responsible for providing at his own expense for all precautions to prevent loss or damage from any and all risks and to minimize the amount of any such loss or damage and for the necessary steps to be taken for the said purpose.
14. **DAMAGE & LOSS TO PRIVATE PROPERTY & INJURY TO CONTRACT EMPLOYEE :-** The Contractor shall at his own expense reinstate and make good to the satisfaction of the SDGM/CCC/LOGISTICS., and pay compensation for any injury, loss or damage occurred to any property or rights whatever including property and rights of BHEL (or agents) servants or employee of BHEL, the injury loss or damage arising out of or in any way in connection with the execution or purported execution of the Contract and further the Contractor shall indemnify, the BHEL against all claims enforceable against BHEL (or any agent, servant or employee of BHEL) or which would be so enforceable against BHEL where BHEL is a private person, in respect of any such injury (including injury resulting in death) loss or damage to any person whomsoever or property including all claims which may arise under the Workmen's Compensation Act or otherwise.
15. **LAWS GOVERNING THE CONTRACT:-** The Contract shall be governed by the Indian Laws for time being in force.
- 15.1 Should a Tenderer or a Contractor has a dependent/relative or in the case of a partnership firm, any of its partners or dependents of partners employed in BHEL, the authority inviting Tenders should be informed of this fact at the time of submission of the Tender failing which Tender may be disqualified or if such fact subsequently come to light, the Contract may be cancelled.
- 15.2 No BHEL employee and their dependents are eligible to submit their offer against this Tender.
16. **CANCELLATION OF CONTRACT FOR CORRUPT ACTS:-** BHEL , whose decision shall be final and conclusive, shall without prejudice to any other right or remedy which shall have accrued shall accrue thereafter to BHEL cancel the Contract in any of the following cases and the Contractor shall be liable to make payment to BHEL for any loss or damage resulting from any such cancellation to the same extend as provided in the case of cancellation for default.

If the Contractor shall:-

Offer or give or agree to give to any person in BHEL service any gift or consideration of any kind, as an inducement or reward for doing or for bearing to do or for having done or for borne to do any act, in relation to the obtaining or execution of this or any other Contract for BHEL service,

OR

Enter in to a Contract with BHEL in connection with which commission has been paid or agreed to be paid by him or with his knowledge, unless the particulars of any such commission and the terms of payment thereof have previously been disclosed in writing to BHEL.

OR

Obtain a Contract with BHEL as a result of ring Tendering or by non-bonafide methods of competitive Tendering, without first disclosing the fact in writing to BHEL

Place:  
Date:

Signature of the Tenderer  
with seal & full address

**17. CANCELLATION OF CONTRACT FOR INSOLVENCY ASSIGNMENT OF TRANSFER OR SUB-LETTING OF CONTRACT :-**

BHEL, without prejudice to any other right or remedy which shall have accrued or shall accrue thereafter to BHEL shall cancel the Contract in any of the following cases:

If the Contractor,

- 17.1 being an individual or if a firm any partner thereof shall at any time be adjudged bankrupt or have a receiving order for administration of his estate, made against him or shall take any proceedings for liquidation or composition under any bankruptcy Act or assignment of his effects of composition or arrangement for the benefit of his creditors or purport to do so, or if any application made under any:

Bankruptcy Act for the time being in force for the sequestration of his estate or if a trust deed be granted by him on behalf of his creditors

**OR**

being a Company, shall pass a resolution or the Court shall make an order for the liquidation of its affairs, or a receiver or Manager on-behalf of the debenture holders shall be appointed or circumstances shall arise which entitle the Court or debenture holders to appoint a receiver or Manager,

**OR**

Assigns, Transfers, Sub-lets or attempts to assign, transfer or sub-let any portion of the work without the prior written approval of the BHEL.

- 17.2 Whenever BHEL exercise the authority to cancel the Contract under this conditions, BHEL may have the work done by any means at the Contractor's risks and expenses provided always that in the event of the cost of the work so done (as certified by SDGM / WCM which is final and conclusive) being less than the Contract cost, the advantage shall accrue to the BHEL and if the cost exceeds the money due to Contractor under the Contract, the Contractor shall either pay the excess amount ordered by SDGM / WCM., or the same shall be recovered from the Contractor by other means.
- 17.3 In case the BHEL carries-out the work under the provisions of this condition the cost to be taken into account in determining the excess cost to be charged to the Contractor under this condition shall consist of the cost of the materials, hire charges of tools and plants and/or labour provided by the BHEL with an addition of such percentage to cover superintendence and establishment charges as may be decided by the SDGM / WCM., whose decision shall be final and conclusive.

**18. CANCELLATION OF CONTRACT IN PART OF FULL FOR CONTRACATOR'S DEFAULT:**

**If the Contractor:**

- 18.1 Makes default in carrying out the work as directed and continues in that state after a reasonable notice from SDGM / WCM., or his authorized representative ;
- 18.2 Fails to comply with any of the Terms and Conditions of the Contract or after reasonable notice in writing with orders properly issued there under;
- 18.3 BHEL, may without prejudice to any other right or remedy which shall have accrued or shall accrue thereafter to BHEL CANCEL the Contract as whole or in part thereof or only such work order or items of work in default from the Contract. Whenever BHEL exercise the authority to cancel the Contract as whole or part under this condition BHEL may complete the work at the Contractor's risk and cost (as certified by SDGM / WCM., which is final and conclusive) being less than the Contract cost, the advantage shall accrue to the BHEL. If the cost exceeds the moneys due to the Contractor under this Contract the Contractor shall either pay the excess amount ordered by SDGM / WCM or the same shall be recovered from the Contractor by other means. In case the BHEL carries out the work or any part thereof under the provisions of the conditions the cost to be taken into account in determining the excess cost to be charged to the Contractor under this condition shall consist of the cost of the materials, hire charges of tools and plant and/or labour provided by the BHEL with an addition of such percentage to cover the superintendence and establishment charges as may be decided by the SDGM / WCM., whose decision shall be final and conclusive.

Place:  
Date:

Signature of the Tenderer  
with seal & full address

- 19. TERMINATION OF CONTRACT ON DEATH OF CONTRACTOR. :-**  
Without prejudice to any of the rights or remedies under this Contract, if the Contractor dies, or if the firm is dissolved or the company is liquidated BHEL shall have the option of terminating the Contract without compensation to the Contractor.
- 20. SPECIAL POWER TO TERMINATION:-** If at any time after the award of Contract, BHEL shall for any reason whatsoever not require whole or any part of the work to be carried out the SDGM / WCM., shall give notice in writing of the fact to the Contractor who shall have no claim to any payment of compensation or otherwise howsoever on account of any profit or advantage which he might have derived from the execution of the work in full but which he did not derive in consequence of the fore-closing of the work.
- 21. RECOVERY FROM CONTRACTOR:-** Whenever under the Contract, any sum of money, shall be recoverable from or payable by the Contractors, the same may be deducted from or any sum. then due or which at any time thereafter may become due to Contractor under the Contract or under any other Contract with BHEL or from his Security Deposit or he shall pay the claim on demand.
- 22. POST TECHNICAL AUDIT OF WORK AND BILLS:-** BHEL reserves the right to carry out the post-payment Audit and technical examination of the work and final bill including all supporting vouchers, abstracts etc., and enforce recovery of any sum becoming due as a result thereof in the manner provided in the presiding sub-paragraphs. However no such recovery shall be enforced after three years of passing the final bill.
- 23. SIGNING OF CONTRACT:-** Each Contract document shall be signed by the Contractor with his usual signature. Contract by partnership of Hindu Joint Family firm, may be signed in the FIRM'S name by one of the Partners or the Karta or Manager as the case may be or by any other duly authorized representative followed by the name and designation of the persons so signing. Contracts by a Company shall be signed with the name of the Company by a person authorized in this behalf and a power of attorney or other satisfactory proof showing that the persons signing the Contract documents on behalf of the Company is duly authorized to do so, shall accompany the Contract.
- 24. ARBITRATION: -** All disputes between the parties to the Contract, arising out-of or relating to the Contract, other than those for which the decision of the SDGM / WCM., or Accepting Officer or any other person is by the Contract expressed to be final and conclusive shall after written notice by either party to the Contract to the other party be referred to the sole Arbitration of Executive Director or other Officers of BHEL appointed as Arbitrator, by the Executive Director of BHEL in his sole discretion.
- 24.1. Unless the parties otherwise agree, such reference shall not take place until after the completion, alleged completion or abandonment of the work of the determination of the Contract.
- 24.2. The venue of Arbitration shall be such a place or places as may be fixed by the Arbitrator in his sole discretion. The award of the Arbitrator shall be final, conclusive and binding on both parties to the Contract.
- 25. JURISDICTION** In case of any suit or other legal proceedings arising under or relating to this Contract, the courts at Trichy, Tamil Nadu only shall have the Jurisdiction and is only after exhausting the, Arbitration
- 26. FORCE MEJEURE CLAUSE:-** If, at any time during the continuance of this Contract the performance in whole or in part by either party of any obligations under this Contract shall be prevented or delayed by reason of any War, Hostile acts of the public enemy Civil Commotion, Epidemics, or Acts of God (Floods, Storm/Cyclone, Hurricane, Earth Quake etc.) then provided notice of happening of any such event is given by either party to other within 7 days from the date of occurrence therefor neither party shall by reason of such event be entitled to terminate this Contract nor shall either party have any claim for damages against the other in respect of such non-performance and delay in performance under the Contract shall be resumed as soon as practicable after such event has come to an end or ceased to exist. If the performance in whole or part of any obligation under this Contract is prevented or delayed by reason of any such event,

Place:  
Date:

Signature of the Tenderer  
with seal & full address

claims for extension of time shall be granted for periods considered reasonable by the SDGM / WCM subject to prompt notification by the Contractor.

**27. STATUTORY REQUIREMENTS:**

- 27.1. All statutory requirements under Minimum Wages Act, 1948, Factories Act 1948, Workmen Compensation Act 1923, Employees Provident Fund and Miscellaneous Provisions Act, 1952, Payment of Gratuity Act 1972, Employee State Insurance Act 1948, Contract Labour (R&A) Act 1970, Payment of Bonus Act 1965, Income Tax Act, Service Tax Act and all other applicable Acts shall be complied with by the Contractor.
- 27.2. Contractor shall comply with all statutory requirements, rules, regulations, notifications in relation to employment of his employees issued from time to time by the concerned authorities.
- 27.3. Contractor shall indemnify BHEL against all claims and losses under various Labour Laws, statutes or any civil or criminal law in connection with employees deployed by him.
- 27.4. Contractor wherever applicable shall maintain proper records prescribed by the concerned statutory authorities and provide a copy of the same to BHEL.
- 27.5. Contractor shall furnish proper returns to the concerned statutory authorities and provide a copy of the same to BHEL.
28. **REGISTERS & RECORDS:-**The Contractor shall maintain all registers and records in the proper manner and as required by the regulations of the various authorities concerned and indemnify the Employer from the consequences due to any inaccurate or faulty documentation on the part of the Contractor.
29. **PRECAUTIONS AGAINST RISK:-** The Contractor shall be responsible for providing at his own expense for all precautions to prevent loss or damage from any and all risks and to minimize the amount of any such loss or damage and for the necessary steps to be taken for the said purpose
30. **REMOTE TRANSACTIONS:-** The Contractor shall agree to and comply with all such terms and conditions as BHEL may prescribe from time to time and shall confirm that all transactions effected by or through facilities for conducting remote transactions including the Internet, World Wide Web, electronic data interchange, call centers, teleservice operations (whether voice, video, data or combination thereof) or by means of electronic, computer, automated machines network or through other means of telecommunication established by BHEL shall constitute legally binding and valid transactions when done.
31. **CHANGE IN CONSTITUTION OF FIRM:-** Changes in constitution of firm whenever it is made after submission of application or during currency of the Contract, the existing firm has to duly inform the proposed changes to Contracting department of BHEL at the appropriate time before the changes in the constitution are made. In case the absence of any such information BHEL is not responsible for the consequences arising out of the absence or suppression of information and the issue / dispute arising out of these changes and the firm is responsible for settling the issue or dispute among themselves (Partners etc.) or with the bankers or with any third party. Under the above circumstances when dispute arises and the firm does not inform the change in the constitution of the firm BHEL has the right for suspending or terminating the Contract.
32. Contractor shall watch and safeguard Employer's interests during the performance of the work. The Contractor shall carefully check each consignment with the relevant Dispatch documents to ensure correctness of each dispatch and each delivery.  
Employer Interests:-  
Contractor shall watch and safeguard Employer's interests during the performance of the work. The Contractor shall carefully check each consignment with the relevant Dispatch documents to ensure correctness of each dispatch and each delivery.

Place:  
Date:

Signature of the Tenderer  
with seal & full address



# भारत हेवी इलेक्ट्रिकल्स लिमिटेड

Bharat Heavy Electricals Limited

High Pressure Boiler Plant, Tiruchirappalli - 620 014.

Phone : 0431 - 2571539, 1573

Email: spswain@bheltry.co.in

Website : www.bhel.com

WORKS CONTRACTS MANAGEMENT

## TECHNO COMMERCIAL BID

ANNEXURE-V

TENDER NO: WCM / 15 / 8013E

dt. 04.03.2016

### SAFETY CONDITIONS

#### 1. The Factories Act, 1948:

**Section 32:** Floors, stairs and means of access shall be properly maintained to ensure safety. Every place of working should have safe access. When any person has to work at a height from which he is likely to fall, provision shall be made, so far as is reasonably practicable, by fencing or otherwise, to ensure the safety of person so working.

#### 2. Tamil Nadu Factories Rules, 1950

**Rule 55:** Hoists and Lifts & Rule 55A. Lifting machines, chains, ropes and lifting tackles: Shall be maintained in good condition, thoroughly inspected and examined by competent persons and records to be maintained.

**Rule 57:** Excessive Weights: No person shall, unaided by another person, lift, carry or move by hand or on head, any material, article, tool or appliance exceeding the maximum limit in weight set out in the schedule (50 kg for adult male and 30 kg for adult female).

**Rule 61E:** Machinery and plant: No machinery, plant or equipment shall be constructed, situated, operated or maintained in any factory in such a manner as to cause risk of bodily injury.

**Rule 61F:** Methods of Work: No process or work shall be carried on in any factory in such a manner as to cause risk of bodily injury.

**Rule 61G:** Stacking and storing of materials etc.: No materials or equipment shall be stacked or stored in such a manner as to cause risk of bodily injury.

**Rule 61-K.** Examination of eye sight of certain workers: No person shall be employed to operate a crane or to give signals to crane operator unless his eye sight and colour vision have been examined and declared fit by a qualified ophthalmologist.

**Rule 61-N and Rule 61- O:** Workers to be provided with Personal Protective equipment suitable for the hazards and should be of good quality / have certification by Indian Standard Institute.

**Note:** For the type of work envisaged, personal protective equipment such as helmet, safety shoes and gloves are essential.

**Rule 96:** Notification of accidents: Shall be complied with as required in the Factories Act (Section 88 and Section 88A) and Tamil Nadu Factories Rules.

#### 3. CONDITIONS RELATED TO THE WELFARE OF LABOURS

- 3.1 The Minimum Wages as prescribed by the State Government from time to time and additional payment as per BHEL circular should be paid to the Contract Workers and the Wage and Attendance Registers should be produced to Welfare Section every month.
- 3.2 If the Contractor employs more than twenty employees, he has to obtain License to this effect from the Factory Inspectorate and renew the same periodically.
- 3.3 He has to have his own PF and ESI Codes and comply with the relevant Acts.
- 3.4 The Contractor has to remit PF for his workers for the same amount which he paid as total wages to the employees on monthly basis. He has to remit 13.61% from his side and deduct 12% of Wages from the monthly wages of the employees and a total of 25.61% of monthly wages should be remitted as PF i.r.o. each employee.
- 3.5 ESI Payment should be at the rate of 6.5% of monthly wages of the employee. This comprises the contribution at 1.75% of wages from the employee and 4.75% of wages from the Contractor.
- 3.6 The Contract workers should be fully aware of safety measures and observe all safety precautions during work. The Contractor should also make his own arrangements to provide requisite safety devices to the workers, based on the nature of work. Any accident / incident occurring to his workers in Company's premises should be reported in writing by the Contractor to Safety, Welfare and Line Executive concerned.

Place:

Date:

Signature of the Tenderer  
with seal & full address

**UNDER TAKING**

Herewith, we..... (Name of the Bidder), certify the following:-

- (i) We have fully understood the technical requirements of the Tender and the type of personnel to be deployed for "Edge preparation of nozzles for 2 steam generators at BHEL, Trichy-14", against the given rate schedule and have quoted accordingly
- (ii) We shall abide by the terms and conditions of Tender Notice Ref. No. WCM / 15 / 8013E Dt. 04.03.2016
- (iii) We ensure that we will pay salary for the personnel engaging in this Contract as per the current minimum wages prescribed by the Government of Tamil Nadu from time to time (BHEL shall be consider as "General Engineering and Fabrication industry" category) which includes basic and DA and also, make an additional payment every month to the Contract Personnel as given below.
- |             |       |                    |
|-------------|-------|--------------------|
| Unskilled   | ----- | ₹ 3200/- per month |
| Semiskilled | ----- | ₹ 3700/- per month |
| Skilled     | ----- | ₹ 4100/- per month |
- (iv) We understand that future revisions of wages made by Tamil Nadu Govt. from time to time shall be borne by us in total and I also know that Price Variation Clause is not applicable. I undertake to pay the revised wages to my workmen.
- (v) We ensure that we will comply with supply of personnel and also we comply with ESI, PF, Bonus, Group Insurance (for both minimum wage and additional wage) and other statutory regulations as stipulated in Factories Act and other applicable State/Central Governments' rules & regulations.
- (vi) I undertake to remit the document for ESI and PF payment for every month and produce proof to BHEL every month along with bill.
- (vii) We have not been suspended or black listed or issued with Show cause Notice by any BHEL Unit
- (viii) All the documents submitted by us against this Tender are genuine documents and are Self attested copies only. At any point of time if found otherwise by BHEL, we accept all the actions viz., legal, Contractual, BHEL Policy / Procedural Actions in whatsoever manner as deemed fit by BHEL.

Place:  
Date:

Signature of the Tenderer  
with seal & full address



# भारत हेवी इलेक्ट्रिकल्स लिमिटेड

Bharat Heavy Electricals Limited

Tiruchirappalli - 620 014

Phone : 0431 - 2571539, 1573,

Email: spswain@bheltry.co.in

Website: www.bhel.com

WORKS CONTRACTS MANAGEMENT

## TECHNO COMMERCIAL BID

ANNEXURE-VI

 70-943	<b>HEALTH, SAFETY AND ENVIRONMENTAL &amp; OCUPATIONAL HEALTH &amp;SAFETY MANAGEMENT SYSTEM</b>	<b>Rev. Date</b>	<b>001 04.05.09</b>
<b>OCP:BSH:003:S</b>	<b>OPERATIONAL CONTROL PROCEDURE</b>	<b>Page</b>	<b>22/1</b>

- (1.) Purpose : To ensure safety & To prevent possible incident in BHEL Trichy-14 While performing job for "Edge preparation of nozzles for 2 steam generators".
- (2.) Scope : ATP BHEL Trichy-14.
- (3.) Responsibility : Area in charges
- (4.) Performance Criteria : Nil incident
- (5.) Cross Reference : OHSAS18002-2007 Clause 4.3.4 & Incident.
- (6.) Incident : Register
- (7.) Activities

S.No.	Activity	Responsibility
1.	Wearing of personal protective equipment's (Safety shoes, gloves) while working	All employees
2.	Ensure that load to be lifted for loading is Well within the limits (SWL) safe working load while loading to vehicles.	Shift supervisors Riggers
3.	Proper staking of Lifting tackles	Riggers
4.	While lifting the materials sling/rope position balancing the load by a trial lifting, if only OK proceed further lift.	Shift supervisors / crane operators / Riggers
5.	Proper scanting between stacks to be provided during staking of components.	Riggers / Loading staff
6.	Safety trailer with load movement	As per OCP: BMM : 014

(8.) **Checking, Corrective and Preventive Action**

(9.) **Records**

Title	Number	Location	Retention period

Place:  
Date:

Signature of the Tenderer  
with seal & full address



# भारत हेवी इलेक्ट्रिकल्स लिमिटेड

Bharat Heavy Electricals Limited

High Pressure Boiler Plant, Tiruchirappalli - 620 014.

Phone : 0431 - 2571539, 1573

Email: spswain@bheltry.co.in

Website : www.bhel.com

**WORKS CONTRACTS MANAGEMENT**

## **TECHNO COMMERCIAL BID**

**ANNEXURE-VII**

TENDER NO: WCM / 15 / 8013E

dt. 04.03.2016

### **TECHNO-COMMERCIAL BID**

The following information's are required for communication for Tender finalization.

#### **GENERAL DETAILS**

SL No	Description	Details
1	Name of Company / Firm	
2	Status of the Company / Firm (Relevant documents must be enclosed)	( ) Public Limited; ( ) Private Limited ( ) Partnership Firm; ( ) Single Ownership
3	Name of Owner / Partner of Firm	
4	Address for Correspondence	
5	Tele Phones	
5.1	Landline	Office
		Residence
5.2	Cell Phone	Office
		Residence
6	Fax Number	
7	E-mail ID	
8	PF Registration Documents copy.	( ) Registered and Copy Enclosed ( ) Not Registered
9	ESI Registration Documents copy.	( ) Registered and Copy Enclosed ( ) Not Registered
10	Service Tax Registration	( ) Registered and Copy Enclosed ( ) Not Registered

1. If Company / Firm is not registered with Service Tax, PF and ESI, they will have to get registered immediately after award of Contract to comply with the statutory requirements.
2. Contractor has to provide copy of Service Tax registration certificate. Wherever Contractor is not registered with Service Tax, a declaration from the Contractor stating that the Contractor is within the threshold limit to be provided. If Contractor has applied for Service Tax registration, a copy of registration is to be provided.

Place:  
Date:

Signature of the Tenderer  
with seal & full address

**ELIGIBILITY CRITERIA FOR TECHNICAL QUALIFICATION****ELIGIBILITY / SELECTION CRITERIA****1 EARNEST MONEY DEPOSIT (EMD)**

<b>DD EMD of ₹20,000/- (Rupees Forty thousand only)</b>		
<b>Sl.No</b>	<b>Description</b>	<b>Details to be filled by the Bidder</b>
1	DD or CR number	
2	Name of the Bank & Branch	

**2 FINANCIAL SOUNDNESS:**

Documents to Prove Financial Soundness of the Firm (in any of the following manner given below) for any of the two consecutive years out of four years i.e., 2011-12, 2012-13, 2013-14 and 2014-15 (Assessment Year 2012-13, 2013-14, 2014-15 & 2015-16).

- ❖ Copy of Income Tax submission acknowledgement  
OR
- ❖ Audited Profit & Loss account and Balance Sheet indicating CA membership number.

**3 EXPERIENCE:**

Work order / Award of Contract / work or contract or service completion certificate copy for work related to scope of work (Machining/Fabrication) issued by any Central / State Govt. / PSU company / Private Organization. Experience certificate from private organization to be supported by TDS (Tax Deducted at Source) certificate issued by the organization OR Form 26 AS or Bank statement for transaction of payment

**4 PAN CARD**

Copy of pan card copy to be enclosed.

Place:  
Date:

Signature of the Tenderer  
with seal & full address

**STATEMENT FOR BID-EVALUATION ON ELIGIBILITY CRITERIA  
(to be filled in by the Bidder)**

**Important:** All the points of the statements to be adequately substantiated invariably with documentary proof thereto. Non-compliance of this requirement shall be deemed fit to reject the Tender primarily on scrutiny on the Tender opening, facilitating freezing of eligibility for price-bid opening.

SL No	Particulars	Compliance status	
1	EMD	DD No. & Date: Bank & Branch:	
<b>2</b>	<b>Financial Soundness</b>		
2.1	Balance Sheet for Assessment Year indication CA membership number of the auditor.	<b>Year</b>	Please Tick (√) in the appropriate box
		2012-13	<input type="checkbox"/> Enclosed / <input type="checkbox"/> Not Enclosed
		2013-14	<input type="checkbox"/> Enclosed / <input type="checkbox"/> Not Enclosed
		2014-15	<input type="checkbox"/> Enclosed / <input type="checkbox"/> Not Enclosed
		2015-16	<input type="checkbox"/> Enclosed / <input type="checkbox"/> Not Enclosed
2.2	Profit & Loss Account for Assessment Year indication CA membership number of the auditor.	<b>Year</b>	
		2012-13	<input type="checkbox"/> Enclosed / <input type="checkbox"/> Not Enclosed
		2013-14	<input type="checkbox"/> Enclosed / <input type="checkbox"/> Not Enclosed
		2014-15	<input type="checkbox"/> Enclosed / <input type="checkbox"/> Not Enclosed
		2015-16	<input type="checkbox"/> Enclosed / <input type="checkbox"/> Not Enclosed
2.3	Copy of Income Tax submission acknowledgment for Assessment Year.	<b>Year</b>	
		2012-13	<input type="checkbox"/> Enclosed / <input type="checkbox"/> Not Enclosed
		2013-14	<input type="checkbox"/> Enclosed / <input type="checkbox"/> Not Enclosed
		2014-15	<input type="checkbox"/> Enclosed / <input type="checkbox"/> Not Enclosed
		2015-16	<input type="checkbox"/> Enclosed / <input type="checkbox"/> Not Enclosed
3	Income Tax PAN No. (PAN Card copy shall be enclosed)		
4	Work order / Award of Contract / work or contract or service completion certificate copy for work related to scope of work (Machining/Fabrication) issued by any Central / State Govt. / PSU company / Private Organization. Experience certificate from private organization to be supported by TDS (Tax Deducted at Source) certificate issued by the organization OR Form 26 AS or Bank statement for transaction of payment		<input type="checkbox"/> Enclosed / <input type="checkbox"/> Not Enclosed

**NOTE: Self attested copy of all the documents should be submitted along with Tender. All the documents submitted by us against this Tender are genuine documents, if at any stage, the document(s) submitted by Contractor is / are found incorrect / false / fake, the necessary action will be taken by BHEL against Contractor viz., legal, Contractual, BHEL Policy / Procedural Actions in whatsoever manner as deemed fit.**

The bidder shall sign on all the copies of technical bid and affix his seal.

Place:  
Date:

Signature of the Tenderer  
with seal & full address

**ANNEXURE-VIII****(ON BIDDER'S LETTER HEAD)****TENDER NO: WCM / 15 / 8013E dt . 04.03.2016****DECLARATION**

I / We M/s. .... do hereby state as follows:-

- (1) The price bids have been put in separate sealed cover.
- (2) The Techno Commercial Bid and all the connected documents have duly been filled in, signed and stamped and put separately in another bigger cover and sealed.
- (3) All the documents & pages have been signed by the Authorized Signatory of the Service Provider, as required, with official seal.
- (4) All the documents required for technical qualification as per eligibility criteria for technical qualification have been enclosed along with techno commercial bid.
- (5) In case there is a lapse / omission or commission in fulfilling the Tender requirements as per the commitments given above from point (1) to (4), we fully understand that it would be a serious violation in complying with the Tender of this nature and that BHEL shall have the right to take a serious view of this and all the actions / decisions of BHEL in this regard will be final and binding on us.
- (6) Details of contractor's group concerns or affiliates etc., who are also engaged contract business.
- (7) Details / particulates of partners / Proprietors / Directors of bidders / such group concerns or affiliates etc. including details of DIN no. (in case of directors) and PAN no. (in case of partners / proprietors) duly supported by self-attested copies of relevant documents.
- (8) confirm that none of its group concern or affiliates etc., appears on the list of banned firms / companies by BHEL (list available on [www.bhel.com](http://www.bhel.com)) nor any of the Director / Partner / proprietor of bidder / such group concern or affiliate etc. are involved with such company.
- (9) Confirm that other than the bidder, none of its group concerns or affiliates etc. are participating in the tender either directly or indirectly through any other agency under same proprietor / common director(s) / common partner(s).

Place:  
Date:Signature of the Tenderer  
with seal & full address



# भारत हेवी इलेक्ट्रिकल्स लिमिटेड

Bharat Heavy Electricals Limited

Tiruchirappalli - 620 014

Phone: 0431 - 2571539, 1573

Email: spswain@bheltry.co.in

Website: www.bhel.coma

WORKS CONTRACTS MANAGEMENT

## PRICE BID

ANNEXURE-IX

SUB:- EDGE PREPARATION OF NOZZLES FOR 2 STEAM GENERATORS AT BHEL TRICHY-14

TENDER NO: WCM / 15 / 8013E

dt. 04.03.2016

01. The Rate quoted shall be firm throughout the currency of the Contract without any price variation Clause. The Tenderer has to quote the Rate / Unit only
02. Rates should be quoted in figures and words and are to be identical if not, the prices in the words will be considered as correct and the same shall be valid and binding.
03. The Rate shall be quoted excluding Service Tax and inclusive of any taxes and duties levied or to be levied both by Central and State Government authorities from time to time. Service Tax will be paid extra on production of documentary evidence.
04. The Rate quoted should be inclusive of cost for the equipment, personnel i.e. skilled, semiskilled, unskilled & supervisors and to execute the above subject scope.
05. Quotation should be valid for a period of 120 days from the date of Tender opening.
06. Contractor will have to make an additional payment per month to the Contract Personnel as given below, over and above the minimum wages prescribed by the Government of Tamil Nadu from time to time. Any amendment to the government notification, from time to time will be applicable and become part and parcel of these conditions.

Unskilled	-----	₹ 3200/-
Semiskilled	-----	₹ 3700/-
Skilled	-----	₹4100/-

incidentals etc., exclusive of Service tax will be the basis for deciding Tender priority (Deciding the L1 Bidder).

07. The contract will be awarded to only one contractor based on the total value of the offer. In case of more than one L1 bidders, BHEL gets fresh revised reduced price bids from all such L1 bidders & ranking will be decided based on these revised bids. The new rates quoted should be lower than their previous L1 rates.

Sl No.	Description	Quantity	Unit	RATE In Rs/UNIT (Excluding Service Tax)
1	Edge preparation of Nozzles for 2 steam generators	2	Nos.	₹...../- Rupees..... .....only

The signature at the bottom of the rate schedule confirms that the Tenderer had read and accepted all the Terms and conditions in Tender Schedule, also rate quoted with inclusive of any taxes and duties levied and excluding Service Tax etc. has been considered by the tenderer for the total contract period while quoting the above rates.

Place:  
Date:

Signature of the Tenderer  
with seal & full address