

INVENTORY NO. 16190057.DWG  
SIGN. AND DATE REF. DRG. NO. 16190057.DWG  
THE INFORMATION ON THIS DOCUMENT IS THE PROPERTY OF BHARAT HEAVY ELECTRICALS LIMITED. IT MUST NOT BE USED DIRECTLY OR INDIRECTLY IN ANY WAY DETRIMENTAL TO THE INTERESTS OF THE COMPANY.

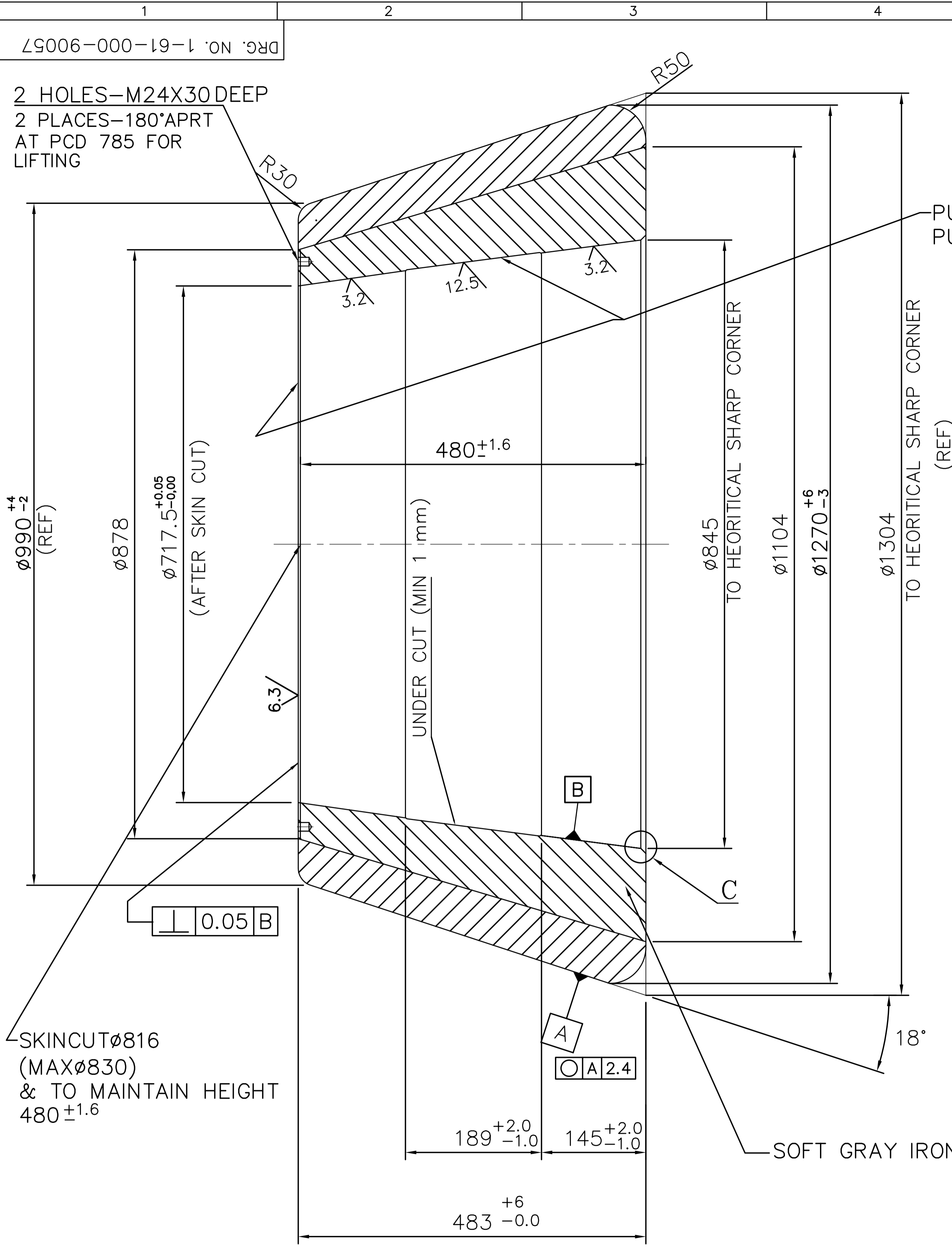

PUNCH ROLL WITH 10 mm PUNCH AT 2 PLACES.

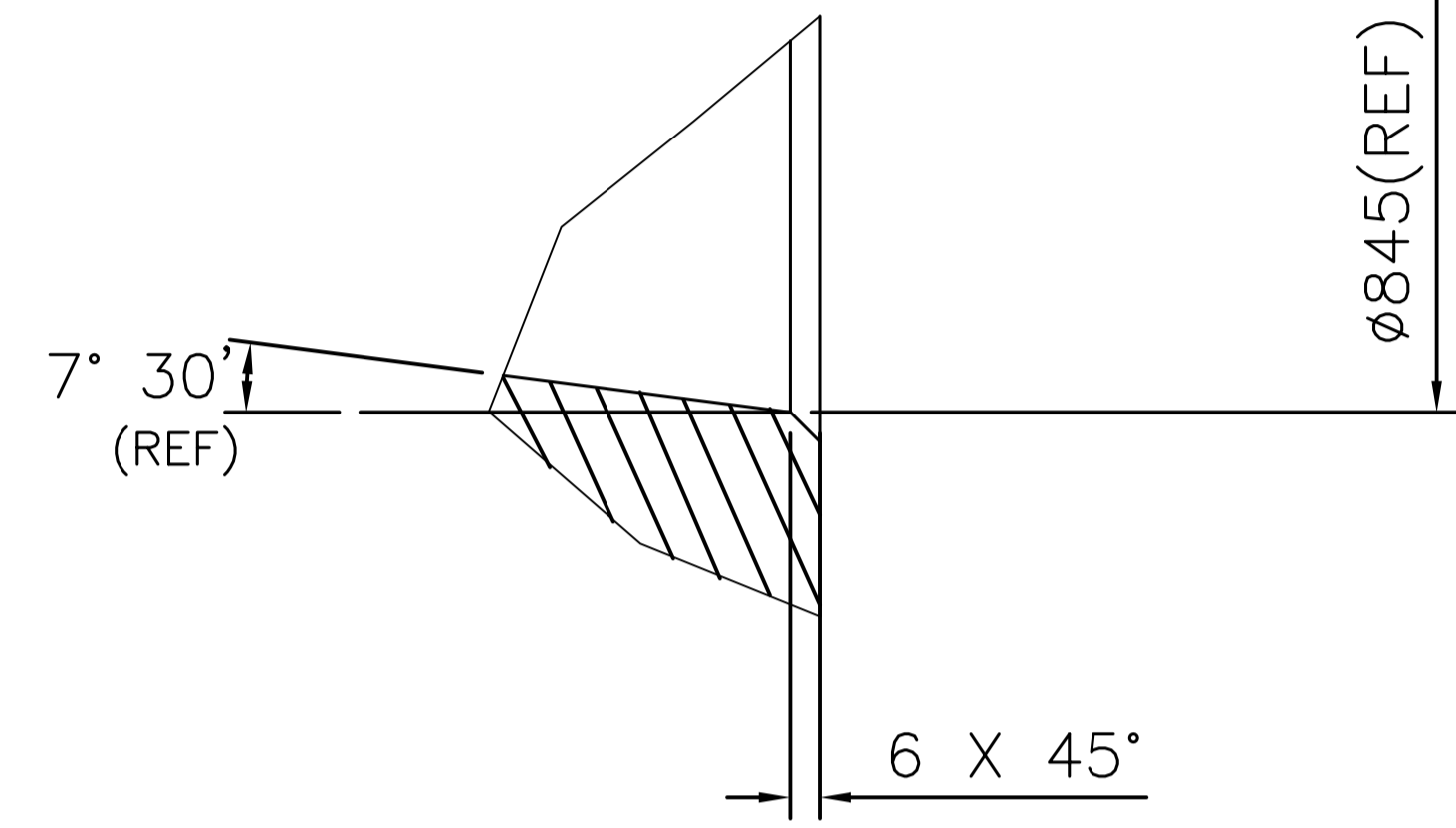

DETAIL-C

NOTES:

1. TOLERANCE FOR UNTOLERENCED DIM FOR CASTING AA0230402 - CLASS3
2. FOR MACHINED DIMENSION AA 0230208 MEDIUM CLASS
3. TAPER MUST BE CHECKED WITH PLATE GUAGE WITH MINIMUM 80% OF ITS CONTACT AREA. CHECKED AT 3 PLACES 120°APART.
4. FOR NIHARD, MINIMUM HARDNESS IS 550 BHN
5. MANUFACTURE AS PER CUSTOMERS / BHEL APPROVED QP.
6. COAT THE MACHINED BORE SURFACE WITH BLUE LACQUER AND REMOVE THE BLUE LACQUER BEFORE ASSY.

| ITEM NO. | DESCRIPTION      | DRAWING NO.      | VAR. NO. | RAW MATERIAL SIZE OR CASTING DRG. NO. OR FORGING DRG. NO. | MATERIAL SPECN. | NET WT. | GROSS WT. |
|----------|------------------|------------------|----------|---|-----------------|---------|-----------|
|          | INSERTS TYPE     | PATTERN M-67-497 | 02       |   | BA9116811011    | 1880.00 | 2180.00   |
|          | CASTING - NIHARD | PATTERN M-67-425 | 01       |   | BA9116850084    | 1880.00 | 2180.00   |
|          |                  |                  |          |   | HY19768         | 1       |           |
|          |                  |                  |          |   |                 |         |           |

THE FOLLOWING CONDITIONS APPLY EXCEPT OTHERWISE STATED.

1. REF. TO HY0230261 FOR UNSPECIFIED TOLERANCES.
2. CHAMFER M/CD. SHARP EDGES 1.2 TO 1.0 AT 45°.
3. INTERNAL M/CD. CORNER RADII 1 TO 0.7
4. THE SURFACE ROUGHNESS WHERE-EVER NOT SHOWN SHALL BE TAKEN FROM THE SURFACE ROUGHNESS SHOWN OUT SIDE THE BACK SLASH GIVEN OR THE TOP MOST RIGHT CORNER OF THE DRG.

|                          |                    |  |                     |                       |              |
|--------------------------|--------------------|--|---------------------|-----------------------|--------------|
| TYPE OF PRODUCT          |                    | XRP 1003                                   |                     |                       |              |
| NAME OF CUSTOMER/PROJECT |                    | BHARAT HEAVY ELECTRICALS LIMITED HYDERABAD |                     |                       |              |
| DRN.                     | NAME               | SIGN.                                      | DATE                | NO.OF VAR.            |              |
| CHD.                     | E.M.A.K.           |  | 15-07-02            |                       |              |
| APPD.                    | S.GHATGE           |  | 15-07-02            |                       |              |
| APPD.                    | RAMANNA            |  | 15-07-02            |                       |              |
| DEPT. 446                | UNTOL. DIMS. C/M/F | SCALE 1:2                                  | WEIGHT (KG) 1880.00 | REF. TO ASSY DRG. --- | ITEM NO. --- |
| CODE PULV.               |                    |  |                     |                       |              |
| TITLE                    |                    | DRAWING NO.                                |                     | REV.                  |              |
| GRINDING ROLL 50"        |                    | 1-61-000-90057                             |                     | 04                    |              |
| SHEET NO.                |                    | NO OF SHEETS                               |                     |                       |              |

| REV. | DATE     | ALTERED CHD./APPD. | REV. | DATE | ALTERED CHD./APPD. | REV. | DATE | ALTERED CHD./APPD. | ZONE |
|------|----------|--------------------|------|------|--------------------|------|------|--------------------|------|
| 04   | 15-07-02 |                    |      |      |                    |      |      |                    |      |

DRG. REDRAWN