

FIRST ANGLE PROJECTION

(ALL DIMENSIONS ARE IN mm)

DRG. NO. 1-61-162-01261

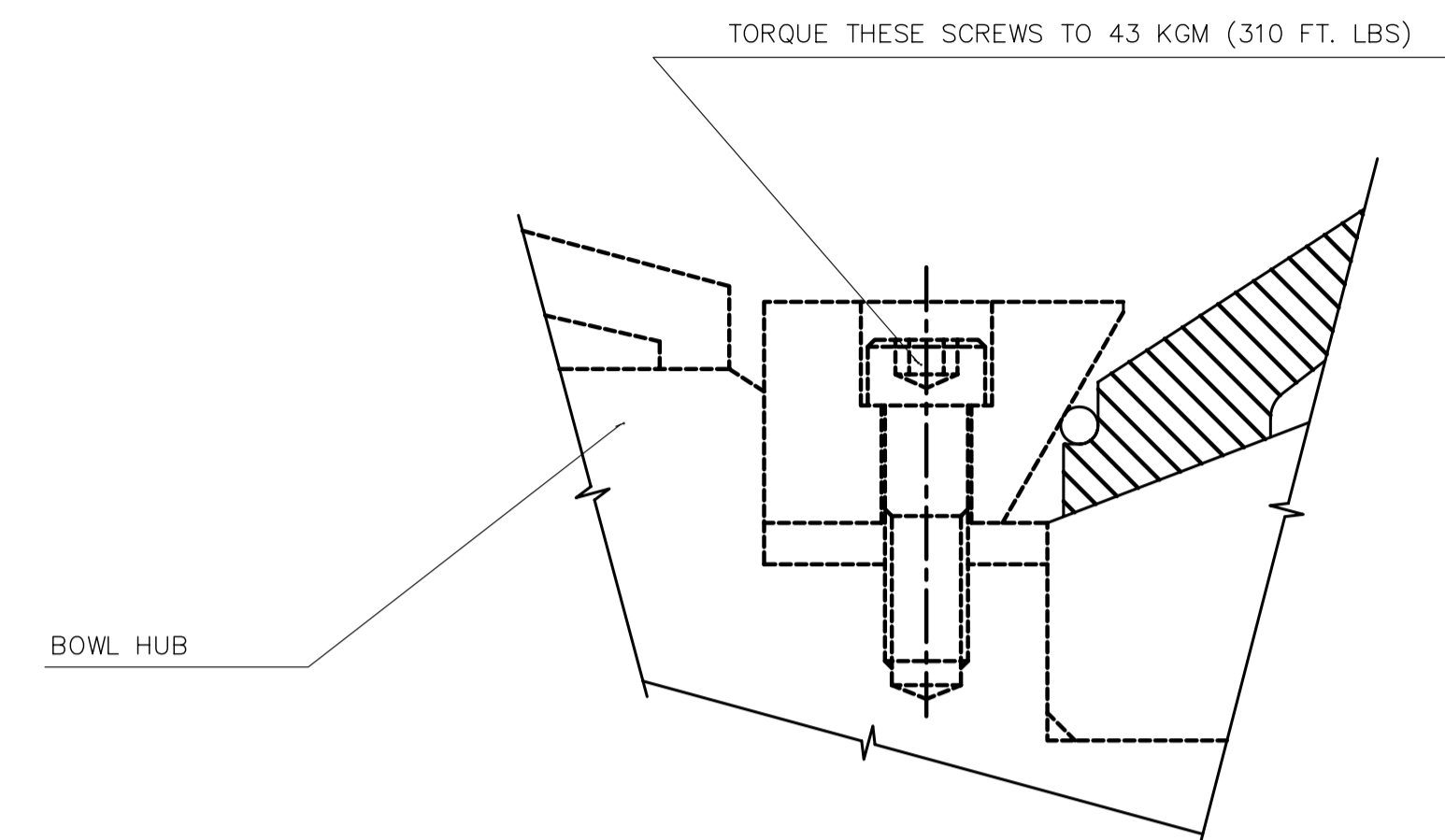
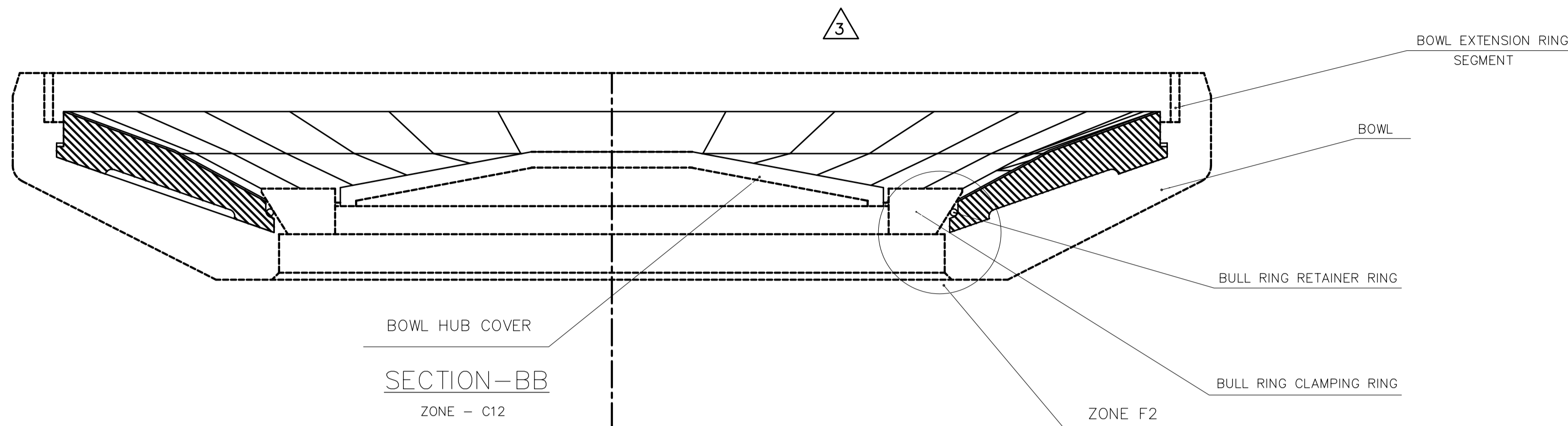

DETAIL-A
SCALE 1:2 ZONE F7

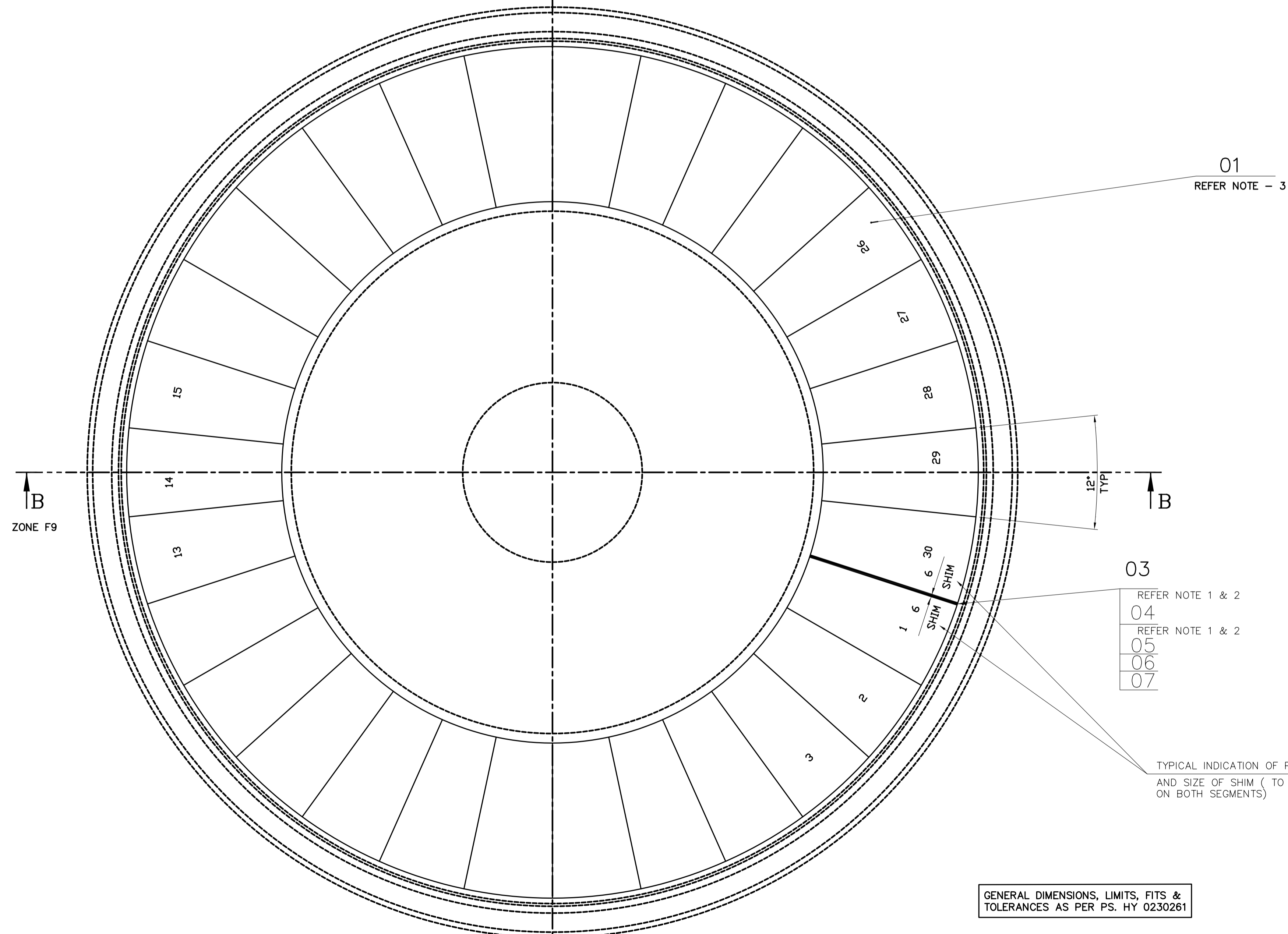

ACCEPTANCE CRITERION ON CHECK BOWL

- GAP BETWEEN THE FIRST AND THE LAST SEGMENT SHALL BE 6 ± 2 MM BEFORE SHIM FITTING.
- USE REQUIRED QUANTITY OF QUARTER SEGMENTS TO ACHIEVE THIS.
- GAP TO BE CLOSED WITH ONE NO. (1) OF 3.15 (VAR 01) OR 6 (VAR 02) SHIM.
- ITEM 2 & 3 SUITING THE BULL RING PROFILE SHALL BE SUPPLIED ALONG WITH THE BULL RING SET IN ADDITION TO THE SHIM REQUIRED TO CLOSE THE GAP OF NOTE 1.

NOTES FOR ASSEMBLY ON ACTUAL BOWL: -

- INSTALL SINGLE SHIM (3.15 mm OR 6 mm THICK AS PER DRG. NO. 3-61-162-00251) AFTER INSTALLING LAST BULL RING SEGMENT DURING SHOP ASSEMBLY.
- IF THE GAP IS MORE THAN 3mm INSTALL ANOTHER SHIM 180° OPPOSITE TO THE FIRST SHIM.
- THE BULL RING SEGMENTS SHOULD BE IN LEVEL WITH EACH OTHER WITHIN 3mm.
- THE GAP BETWEEN THE SEGMENTS SHOULD BE LIMITED TO LESS THAN 1.6mm NO GAP ALLOWED. AT THE INNER & OUTER RADIUS.
- ONE OF THE ITEMS 04 & 05 MAY BE REQUIRED DURING ASSY
- THERE SHALL BE MIN 6 SEGMENTS GAP BETWEEN ANY 2 SHIMS, BETWEEN ANY TWO QUARTER SEGEMENTS OR BETWEEN A SHIM AND A QUARTER SEGMENT.

03	REFER NOTE 1 & 2
04	REFER NOTE 1 & 2
05	
06	
07	

TYPICAL INDICATION OF POSITION AND SIZE OF SHIM (TO BE PAINTED ON BOTH SEGMENTS)

GENERAL DIMENSIONS, LIMITS, FITS & TOLERANCES AS PER PS. HY 0230261

ITEM NO.	DESCRIPTION	STD	DRAWING NO.	ITEM NO. VAR NO.	MATL CODE	A	UNIT	UNIT WT.	GS	ZONE
05	BULL RING SEGMENT (HALF)		2-61-162-02482				10	00		
04	BULL RING SEGMENT (QUARTER)		2-61-162-02481				5	60		
03	SHIM		3-61-162-00251	02			1	10		
02	SHIM		3-61-162-00251	01			0	60		
01	BULL RING SEGMENT - PLAIN		2-61-162-02480				20	40		

TYPE OF PRODUCT OR NAME OF CUSTOMER/PROJECT: **623 XRP BOWL MILL**

BHARAT HEAVY ELECTRICALS LTD. HYDERABAD

DRN. NDSAMUEL 08.07.99
APPD. S.GHATGE 08.07.99

DEPT. BULLY ENGR. CODE 446
SCALE 1:5
WEIGHT (KG) 629.30

DRAWING NO. 1-61-162-01261
SHEET NO. 1 NO OF SHEETS 1

REV.	DATE	ALTERED	CHECKED	APPROVED	REV.	DATE	ALTERED	CHECKED	APPROVED	REV.	DATE	ALTERED	CHECKED	APPROVED	REV.	DATE	ALTERED	CHECKED	APPROVED	
01	24.2.04																			

THE INFORMATION ON THIS DOCUMENT IS THE PROPERTY OF BHARAT HEAVY ELECTRICALS LIMITED. IT MUST NOT BE USED DIRECTLY OR INDIRECTLY IN ANY WAY DETRIMENTAL TO THE INTEREST OF THE COMPANY.
 INVENTORY NO. 16101261.DWG
 SIGN. AND DATE
 REF. DRG. NO.
 24-09-2008
 11.15.02