



An ISO 9001  
Company

# Bharat Heavy Electricals Limited

(High Pressure Boiler Plant)

Tiruchirappalli – 620014, TAMIL NADU, INDIA

MATERIALS MANAGEMENT

<b>TITLE</b>	Phone: +91 431 257 7897
<b>Supply of Graphite Alloy Bearing &amp; Bushing</b>	Fax : +91 431 252 0719
	Email : <a href="mailto:sachinsaini@bheltry.co.in">sachinsaini@bheltry.co.in</a>

	<b>Reference Number:</b> Enquiry 1801501116	<b>Enquiry Date:</b> 01.10.2015	<b>Due date for submission of quotation:</b> 02.11.2015
--	--	------------------------------------	---

You are requested to quote the Enquiry number date and due date in all your correspondences. This is only a request for quotation and not an order

**BHEL/Trichy is looking for empanelment of new vendors for supply of Graphite Alloy Bearing & Bushing as per attached technical specifications.**

BHEL commercial terms & conditions with Price Bid formats and all annexure can be downloaded from BHEL web site <http://www.bhel.com> or from the Government tender website <http://tenders.gov.in> (public sector units) Bharath Heavy Electricals Limited) under enquiry reference "XXXXXXXXXX "

Tenders should be submitted online before 12:30 hours on the due date Technical bid will be opened at 13:00 hours on the due date	Yours faithfully, For <b>Bharath Heavy Electricals Limited</b>  <b>DGM / MM</b>
--	--

**RFQ/NIT HEADER DETAIL**

ORGANIZATION NAME	TRICHY, BHEL	PROCUREMENT CATEGORY	PROCUREMENT CATEGORY
RFQ/NIT REFERENCE	1801501116	RFQ OWNER/NIT	MR Sachin Saini(ENGR/PUR)
CODE/ENQUIRY NO		OFFICER/ENQUIRY OWNER	
NUMBER OF ITEMS ALREADY	4		
ATTACHED			
CURRENCY	ANY		
DESCRIPTION	Supply of Graphite Alloy Bearing and Bushings		
DETAILED DESCRIPTION	Supply of Graphite Alloy Bearing and Bushings to BHEL Trichy		
NUMBER OF BID PART(S)	2	PUBLISHED DATE	01/10/2015 03:33:50 PM

**ATTRIBUTE (S)**

ATTRIBUTE NAME	ATTRIBUTE VALUE
Delivery at	As per section V of TED
Inspection By	BHEL or BHEL TPI
Validity of the Offer	PRICE SHOULD BE FIXED AND VALID FOR 90 day FROM THE DATE OF OFFER
Inspection	AT VENDOR WORKS

**DATE-TIME DETAIL (S)**

BID START DATE	Oct 1, 2015	BID DUE DATE	Nov 2, 2015 12:30:00:PM
BID OPEN DATE	Nov 2, 2015 01:00:00:PM		
(SCHEDULED)			

**PRE-BID DISCUSSION DETAILS**

PRE-BID DISCUSSION TYPE NOT REQUIRED

**ALTERNATE BID DECRYPTOR (S)**

USER DETAILS
MR B. SANJEEVI (DGM/PUR)
MR KRISHNAMURTHY S (DGM/PUR)
MR Sachin Saini (ENGR/PUR)
MR SELVARAJU S (SM/PUR)
MR GOVINDA MAHATO (AE1/PUR)

**SELLER DETAIL (S)**

CODE	ORGANIZATION NAME
023505	TEST (Mr test ot test)

**TERM AND CONDITION DETAIL(S) - SPECIAL TERM(S)**

SL. NO.	CATEGORY	DESCRIPTION
---------	----------	-------------



1	SPECIAL TERM(S)	<p>SPECIAL TERM(S)</p> <p>Any Purchase Order resulting from this tender enquiry shall be governed by all terms &amp; conditions mentioned in enclosed Tender Enquiry Document (TED) below and special/commercial terms and conditions, if any, along with this enquiry of Bharat Heavy Electricals Limited, BHEL HBPB, Trichy-620014 (hereinafter referred to as BHEL Trichy).</p> <p>The offer has to be submitted in two part bid system i.e technical bid along with documents as per section XV &amp; price bid (in format as per Section VIII) separately through e-procurement route only.</p> <p>The tender will be evaluated on ITEM WISE cost to BHEL basis.</p> <p>All corrigenda/addenda/amendments/time extensions/clarifications, etc. to the tender will be hosted on BELOW website(s) only and will not be published in any other media. Bidders should regularly visit above website(s) to keep themselves updated.</p> <p><a href="http://tenders.gov.in">http://tenders.gov.in</a>  <a href="http://www.bhel.com">http://www.bhel.com</a>  <a href="http://eprocure.gov.in">http://eprocure.gov.in</a>  <a href="https://bheleps.buyjunction.in">https://bheleps.buyjunction.in</a></p> <p>The bidder along with its associate/ collaborators/ sub-contractors/ sub-vendors/ consultants/ serviceproviders shall strictly adhere to BHEL fraud prevention policy displayed on BHEL website <a href="http://www.bhel.com">http://www.bhel.com</a> and shall immediately bring to the notice of BHEL management about any fraud or suspected fraud as soon as it comes to their notice.</p> <p>MSE clause is applicable for this tender as per section XIV of TED.</p>
---	-----------------	--

**RFQ/NIT ITEM DETAILS**

SL. NO.	CODE	DESCRIPTION																		
10	0000097038001000	Grahpite Alloy Damper Beaing as per spec TFS1001A /Rev 02. Drawing no. 4-45-320-01618A																		
488.00	NUMBER	NUMBER																		
	ATTRIBUTE DETAILS	<table border="1"> <thead> <tr> <th>ATTRIBUTE NAME</th> <th>ATTRIBUTE VALUE</th> </tr> </thead> <tbody> <tr> <td>MATERIAL CODE:</td> <td>00000970380010000</td> </tr> <tr> <td>MATERIAL GROUP:</td> <td>45GRB</td> </tr> <tr> <td>KILOGRAM PER UNIT:</td> <td>1.0 (PERCENTAGE)</td> </tr> <tr> <td>Cenvatable (Yes / No)</td> <td>Yes</td> </tr> <tr> <td>Delivery Location</td> <td>TAMIL NADU</td> </tr> <tr> <td>Vatable (Yes / No)</td> <td>Yes</td> </tr> <tr> <td>Delivery Date (i) :</td> <td>24-APR-2016</td> </tr> <tr> <td>Delivery Qty (i) :</td> <td>488</td> </tr> </tbody> </table>	ATTRIBUTE NAME	ATTRIBUTE VALUE	MATERIAL CODE:	00000970380010000	MATERIAL GROUP:	45GRB	KILOGRAM PER UNIT:	1.0 (PERCENTAGE)	Cenvatable (Yes / No)	Yes	Delivery Location	TAMIL NADU	Vatable (Yes / No)	Yes	Delivery Date (i) :	24-APR-2016	Delivery Qty (i) :	488
ATTRIBUTE NAME	ATTRIBUTE VALUE																			
MATERIAL CODE:	00000970380010000																			
MATERIAL GROUP:	45GRB																			
KILOGRAM PER UNIT:	1.0 (PERCENTAGE)																			
Cenvatable (Yes / No)	Yes																			
Delivery Location	TAMIL NADU																			
Vatable (Yes / No)	Yes																			
Delivery Date (i) :	24-APR-2016																			
Delivery Qty (i) :	488																			
20	0000097038002000	Grahpite Alloy Damper Bushing as per spec (TFS1001A/ Rev 02), drawing 3-45-000-01273A																		
400.00	NUMBER	NUMBER																		
	ATTRIBUTE DETAILS	<table border="1"> <thead> <tr> <th>ATTRIBUTE NAME</th> <th>ATTRIBUTE VALUE</th> </tr> </thead> <tbody> <tr> <td>MATERIAL CODE:</td> <td>00000970380020000</td> </tr> <tr> <td>MATERIAL GROUP:</td> <td>45GRB</td> </tr> <tr> <td>KILOGRAM PER UNIT:</td> <td>1.0 (PERCENTAGE)</td> </tr> <tr> <td>Cenvatable (Yes / No)</td> <td>Yes</td> </tr> <tr> <td>Delivery Location</td> <td>TAMIL NADU</td> </tr> <tr> <td>Vatable (Yes / No)</td> <td>Yes</td> </tr> <tr> <td>Delivery Date (i) :</td> <td>24-APR-2016</td> </tr> <tr> <td>Delivery Qty (i) :</td> <td>400</td> </tr> </tbody> </table>	ATTRIBUTE NAME	ATTRIBUTE VALUE	MATERIAL CODE:	00000970380020000	MATERIAL GROUP:	45GRB	KILOGRAM PER UNIT:	1.0 (PERCENTAGE)	Cenvatable (Yes / No)	Yes	Delivery Location	TAMIL NADU	Vatable (Yes / No)	Yes	Delivery Date (i) :	24-APR-2016	Delivery Qty (i) :	400
ATTRIBUTE NAME	ATTRIBUTE VALUE																			
MATERIAL CODE:	00000970380020000																			
MATERIAL GROUP:	45GRB																			
KILOGRAM PER UNIT:	1.0 (PERCENTAGE)																			
Cenvatable (Yes / No)	Yes																			
Delivery Location	TAMIL NADU																			
Vatable (Yes / No)	Yes																			
Delivery Date (i) :	24-APR-2016																			
Delivery Qty (i) :	400																			
30	0000097038003000	Grahpite Alloy Damper Bushing as per spec TFS1001A/Rev 02, drawing no. 3-45-000-01283A																		
488.00	NUMBER	NUMBER																		



	ATTRIBUTE DETAILS	<b>ATTRIBUTE NAME</b>	<b>ATTRIBUTE VALUE</b>
		MATERIAL CODE:	000000970380030000
		MATERIAL GROUP:	45GRB
		KILOGRAM PER UNIT:	1.0 (PERCENTAGE)
		Cenvatable (Yes / No)	Yes
		Delivery Location	TAMIL NADU
		Vatable (Yes / No)	Yes
		Delivery Date (i) :	24-APR-2016
		Delivery Qty (i) :	488
40	000000970380040 000	Graphite Alloy Damper Bushing as per spec TFS1001A/Rev 02, drawing no.3-45-000-01283A	
488.00	NUMBER	NUMBER	
	ATTRIBUTE DETAILS	<b>ATTRIBUTE NAME</b>	<b>ATTRIBUTE VALUE</b>
		MATERIAL CODE:	000000970380040000
		MATERIAL GROUP:	45GRB
		KILOGRAM PER UNIT:	1.0 (PERCENTAGE)
		Cenvatable (Yes / No)	Yes
		Delivery Location	TAMIL NADU
		Vatable (Yes / No)	Yes
		Delivery Date (i) :	24-APR-2016
		Delivery Qty (i) :	488

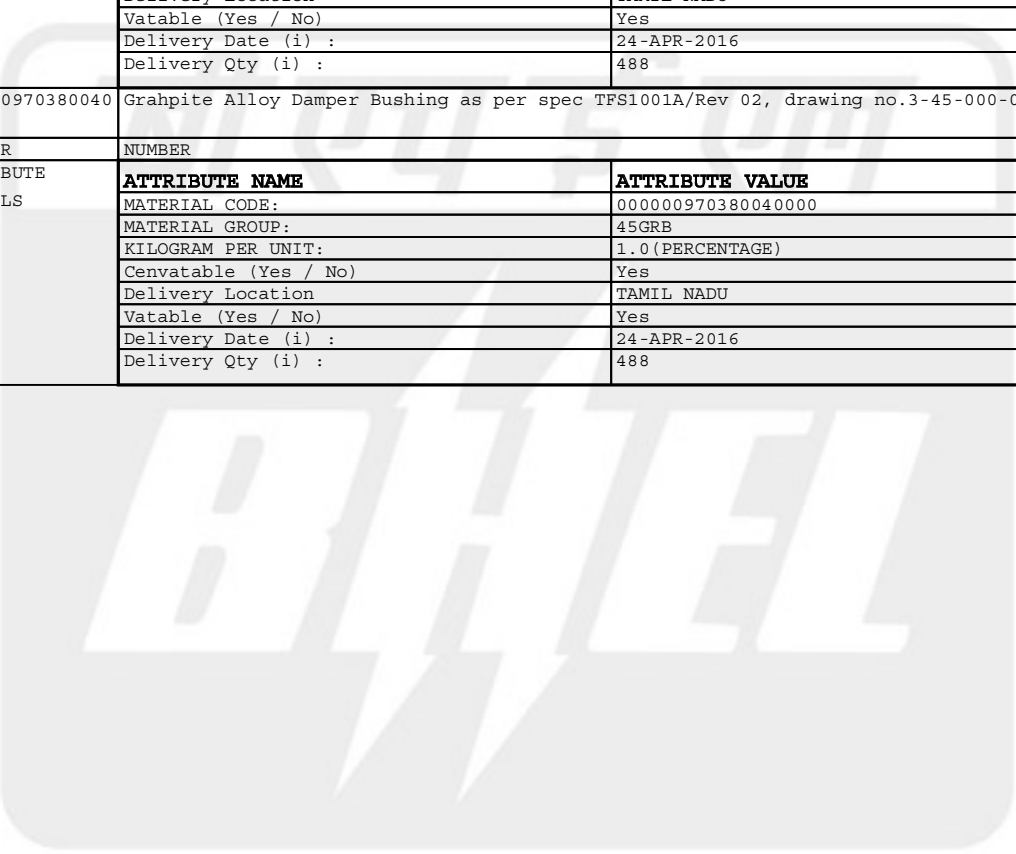

**IMPORTANT NOTICE**

PLEASE READ THE FOLLOWING ATTACHMENT(S) [SEPARATELY DOWNLOADABLE] ALONG WITH THIS RFQ/NIT/ENQUIRY .

**RFQ/NIT/ENQUIRY - ATTACHMENTS**

<b>LABEL</b>	<b>FILE NAME</b>
TED	Tender Enquiry Document.docx
Specifications Drawing	Specifications Drawing.pdf



# GLOBAL TENDER ENQUIRY DOCUMENT

(Through e-Procurement route)

FOR THE PURCHASE OF

Graphite Alloy Bearing & Bushing  
BY BHEL TRICHY

**ENQUIRY NO: 1801501116 DATED 01.10.2015**



**BHARAT HEAVY ELECTRICALS LTD,  
TIRUCHIRAPALLI-14**

(A GOVERNMENT OF INDIA UNDERTAKING)

PHONE: 0431 257 7897

FAX: 0431 2520719

EMAIL: [sachinsaini@bheltry.co.in](mailto:sachinsaini@bheltry.co.in)

## Index

Section	Topic	Page No
<b>Section I</b>	Notice Inviting e-tender	<b>3</b>
<b>Section II</b>	General Instructions to Tenderers (GIT)	<b>5</b>
<b>Section III</b>	General conditions of contract (GCC)	<b>15</b>
<b>Section IV</b>	Special conditions of contract (SCC)	<b>24</b>
<b>Section V</b>	List of Requirements	<b>25</b>
<b>Section VI</b>	Technical and Quality Specifications	<b>26</b>
<b>Section VII</b>	Tender Form	<b>27</b>
<b>Section VIII</b>	Price bid Formats	<b>28</b>
<b>Section IX</b>	Reverse Auction	<b>29</b>
<b>Section X</b>	Bank Guarantee Format for Performance (PBG)	<b>30</b>
<b>Section XI</b>	Loading Criteria	<b>33</b>
<b>Section XII</b>	Special & Commercial terms	<b>34</b>
<b>Section XIII</b>	Supplier Registration Form	<b>38</b>
<b>Section XIV</b>	MSE Clause	<b>39</b>
<b>Section XV</b>	Guidelines for submitting tender	<b>40</b>

Enclosures:-

1. Technical specifications TFS:1001A/Rev.02
2. Drawing nos 4-45-320-01618A, 3-45-000-01273A/Var 03, 3-45-000-01283A/Var 08 & 3-45-000-01283A/Var 09

**SECTION I**

NOTICE INVITING GLOBAL E-TENDER (NIT)

from

**BHARAT HEAVY ELECTRICALS LTD, TIRUCHIRAPALLI-14**

(A GOVERNMENT OF INDIA UNDERTAKING)

PHONE: 0431 257 7897

FAX: 0431 252 0719

EMAIL: [sachinsaini@bheltry.co.in](mailto:sachinsaini@bheltry.co.in)

For

BHEL Trichy Stores

**Enquiry No: 1801501116 date 01.10.2015****NOTICE INVITING e-TENDERS (NIT)**

- 1) Material Management/BOI, invites online tenders, from eligible and qualified tenderers for supply of Graphite Alloy Bearing & Bushing to BHEL Trichy Stores (Ward 26).

Sr. NO	Enquiry No	Item Name	Department	Quantity	EMD
1	1801501116	Graphite Alloy Bearing & Bushing	MM/BOI	1864 Nos	Nil

- 2) Enquiry No: 1801501116 date 01.10.2015

Sr. No	Description	Schedule
1	Cost of the Tender Enquiry Document	NIL
2	Pre-bid meeting date, time & Venue	NIL
3	Closing date & time for submission of tender fee and EMD in physical form	NA
4	Closing date & time for submission of online bids	01.10.2015 12:30 hrs IST
5	Time and date of opening of online bids	01.10.2015 13:00 hrs IST
6	Venue for :- a. Submission of tender fee, EMD in physical form. b. E-Tender Opening-Tech Bid	NA

BHEL Trichy has implemented e-Procurement ([www.bheleps.buyjunction.in](http://www.bheleps.buyjunction.in)) and it is going to be the way of working in future.

**The Requirement:**

1. A PC with Internet connectivity &
2. DSC (Digital Signature Certificate)( **Class 3- SHA2- 2048 BIT- SIGNING & ENCRYPTION**)

**The following are the benefits of e-Procurement Process.**

1. Ensuring no offer is missed due to last minute submission, postal delays etc.
2. Reduced Tendering & ordering cycle time
3. Economical, smoother & speedy communication
4. Greater Transparency
5. Big step towards paperless procurement process, Minimal human error
6. No geographical barriers
7. Vendor gets alerts regarding issue of new tender enquiry, amendments, clarifications etc
8. Submission of offer from the comforts of their office from any location
9. on line clarifications
10. Direct Cost Savings such as reduced Paper costs, reduced printing costs, reduced mailing costs, reduced telephone costs and reduced fax costs.

BHEL has finalized the e-procurement service Provider

**M/s mJunction services Limited, Kolkata**

Godrej Water Side, 3rd Floor, Tower-1, Plot-V, Block - DP  
Sector - V, Salt Lake, Kolkata-700091, West Bengal, INDIA

Please get in touch with them immediately. The contact details of the service provider is given below:

- a. DHANARAJ.P email: [panneer.dhanaraj@mjunction.in](mailto:panneer.dhanaraj@mjunction.in), Cell 9500199108
- b. HELPDESK email: [eps.customercare@mjunction.in](mailto:eps.customercare@mjunction.in), Phone No: 033-66106426/6217/6013/6046/6176, 9163348283 / 9163348284 / 9163348285 / 9163348286 / 8584008116

The process of utilizing e-procurement necessitates usage of DSC (Digital Signature Certificate)( **Class 3- SHA2- 2048 BIT- SIGNING & ENCRYPTION**) and you are requested to procure the same immediately, if not presently available with you. Please note that only with DSC, you will be able to login the e-procurement secured site and take part in the tendering process. The contact details of the DSC Certifying Authority as given below

1	<b>e-Mudhra</b>	<a href="http://www.e-Mudhra.com">http://www.e-Mudhra.com</a>	5	<b>NIC</b>	<a href="http://www.safescrypt.com">www.safescrypt.com</a>
2	<b>GNFC</b>	<a href="http://www.ncodesolutions.com">www.ncodesolutions.com</a>	6	<b>Safescrypt</b>	<a href="http://www.safescrypt.com">www.safescrypt.com</a>
3	<b>IDRBT</b>	<a href="http://www.idrbtca.org.in">www.idrbtca.org.in</a>	7	<b>TCS</b>	<a href="http://www.tcs-ca.tcs.co.in">www.tcs-ca.tcs.co.in</a>
4	<b>MTNLTrustline</b>	<a href="http://www.mtnltrustline.com">www.mtnltrustline.com</a>			

Vendors are requested to go through seller manual available on [www.bheleps.buyjunction.in](http://www.bheleps.buyjunction.in)

## SECTION - II

### GENERAL INSTRUCTIONS TO TENDERERS (GIT)

#### 1. Definitions and Abbreviations

The following definitions and abbreviations, which have been used in these documents shall have the meanings as indicated below:

##### a. Definitions:

- i. **“Purchaser”** means BHEL Trichy.
- ii. **“e-Tender”** means Bids / Quotation / Tender received from a Firm / Tenderer / Bidder online. And **“Tenderer”** means Bidder/ the Individual or Firm submitting tenders/ Bids / Quotation / e-Tenders.
- iii. **“Supplier”** means the individual or the firm supplying the goods and services as incorporated in the contract.
- iv. **“Goods”** means the articles, material, commodities, livestock, furniture, fixtures, raw material, spares, instruments, machinery, equipment, industrial plant etc. which the supplier is required to supply to the purchaser under the contract.
- v. **“Services”** means services allied and incidental to the supply of goods, such as transportation, installation, commissioning, provision of technical assistance, training, after sales service, maintenance service and other such obligations of the supplier covered under the contract.
- vi. **“Earnest Money Deposit”** (EMD) means Bid Security/ monetary or financial guarantee to be furnished by a tenderer along with its tender.
- vii. **“Contract”** means the written agreement entered into between the purchaser and/or consignee and the supplier, together with all the documents mentioned therein and including all attachments, annexure etc. therein.
- viii. **“Performance Security”** means monetary or financial guarantee to be furnished by the successful tenderer for due performance of the contract placed on it. Performance Security is also known as Security Deposit.
- ix. **“Consignee”** means the site/stores/ person to whom the goods are required to be delivered as specified in the Contract. If the goods are required to be delivered to a person as an interim consignee for the purpose of dispatch to another person as provided in the Contract then that “another” person is the consignee, also known as ultimate consignee.
- x. **“Specification”** means the document/standard that prescribes the requirement with which goods or service has to conform.
- xi. **“Inspection”** means activities such as measuring, examining, testing, gauging one or more characteristics of the product or service and comparing the same with the specified requirement to determine conformity.
- xii. **“Day”** means calendar day.

##### b. Abbreviations:

- (i) “TE Document” means Tender Enquiry Document
- (ii) “NIT” means Notice Inviting Tenders.
- (iii) “GIT” means General Instructions to Tenderers
- (iv) “SIT” means Special Instructions to Tenderers (SIT not applicable for this enquiry)
- (v) “GCC” means General Conditions of Contract

- (vi) "SCC" means Special Conditions of Contract
- (vii) "DGS&D" means Directorate General of Supplies and Disposals
- (viii) "NSIC" means National Small Industries Corporation
- (ix) "PSU" means Public Sector Undertaking
- (x) "CPSU" means Central Public Sector Undertaking
- (xi) "LSI" means Large Scale Industry
- (xii) "SSI" means Small Scale Industry
- (xiii) "LC" means Letter of Credit
- (xiv) "DP" means Delivery Period
- (xv) "BG" means Bank Guarantee
- (xvi) "ED" means Excise Duty
- (xvii) "CD" means Custom Duty
- (xviii) "VAT" means Value Added Tax
- (xix) "CENVAT" means Central Value Added Tax
- (xx) "CST" means Central Sales Tax
- (xxi) "RR" means Railway Receipt
- (xxii) "BL" means Bill of Lading
- (xxiii) "FOB" means Free on Board
- (xxiv) "FCA" means Free Carrier
- (xxv) "FOR" means Free On Rail
- (xxvi) "CIF" means Cost, Insurance and Freight
- (xxvii) "CIP (Destinations)" means Carriage and Insurance Paid up to named port of destination. Additionally the Insurance (local transportation and storage) would be extended and borne by the Supplier from ware house to the consignee site for a period including 3 months beyond date of delivery.
- (xxviii) "DDP" means Delivery Duty Paid named place of destination (consignee site)
- (xxix) "INCOTERMS" means International Commercial Terms as on the date of Tender Opening
- (xxx) "EPS" – BHEL's e-procurement system (<https://bheleps.buyjunction.in>)

## 2. Introduction

**2.1** The Purchaser has issued these TE documents for purchase of goods and related services as mentioned in Section – V – "List of Requirements", which also indicates, *interalia*, the required delivery schedule, terms and place of delivery.

**2.2** This section (Section II - "General Instruction Tenderers") provides the relevant information as well as instructions to assist the prospective tenderers in preparation and submission of tenders. It also includes the mode and procedure to be adopted by the purchaser for receipt and opening as well as scrutiny and evaluation of tenders and subsequent placement of contract.

**2.3** ~~The tenderers shall also read the Special Instructions to Tenderers (SIT) related to this purchase, as contained in Section III of these documents and follow the same accordingly. Whenever there is a conflict between the GIT and the SIT, the provisions contained in the SIT shall prevail over those in the GIT. Not applicable for this tender enquiry.~~

**2.4** Before formulating the tender and submitting the same to the purchaser, the tenderer should read and examine all the terms, conditions, instructions, checklist etc. contained in the TE documents. Failure to provide and/or comply with the required information, instructions etc. incorporated in these TE documents may result in rejection of its tender.

## 3. Availability of Funds

**3.1** Expenditure to be incurred for the proposed purchase will be met from the funds available with the purchaser/consignee.

#### **4. Language of Tender**

**4.1** The tender submitted by the tenderer and all subsequent correspondence and documents relating to the tender exchanged between the tenderer and the purchaser, shall be written in the English language, unless otherwise specified in the Tender Enquiry. However, the language of any printed literature furnished by the tenderer in connection with its tender may be written in any other language provided the same is accompanied by an English translation and, for purposes of interpretation of the tender, the English translation shall prevail.

**4.2** The tender submitted by the tenderer and all subsequent correspondence and documents relating to the tender exchanged between the tenderer and the purchaser, may also be written in the Hindi language, provided that the same are accompanied by English translation, in which case, for purpose of interpretation of the tender etc, the English translations shall prevail.

#### **5. Eligible Tenderers**

**5.1** This invitation for tenders is open to all Indigenous supplies who fulfil the eligibility criteria specified in these documents.

#### **6. Eligible Goods and Services**

**6.1** All goods and related services to be supplied under the contract shall have their origin in India or any other country with which India has not banned trade relations. The term "origin" used in this clause means the place where the goods are mined, grown, produced, or manufactured or from where the related services are arranged and supplied.

#### **7. Tendering Expense**

**7.1** The tenderer shall bear all costs and expenditure incurred and/or to be incurred by it in connection with its tender including preparation, mailing and submission of its tender and for subsequent processing the same. The purchaser will, in no case be responsible or liable for any such cost, expenditure etc regardless of the conduct or outcome of the tendering process.

#### **8. Content of Tender Enquiry Documents**

**8.1** In addition to

Section I	Notice Inviting e-tender
Section II	General Instructions to Tenderers (GIT)
Section III	General conditions of contract (GCC)
Section IV	Special conditions of contract (SCC)
Section V	List of Requirements
Section VI	Technical and Quality Specifications
Section VII	Tender Form
Section VIII	Price bid Formats
Section IX	Reverse Auction
Section X	Bank Guarantee Format for Performance (PBG)
Section XI	Loading Criteria
Section XII	Special & Commercial terms
Section XIII	Supplier Registration Form
Section XIV	MSE Clause
Section XV	Guidelines for submitting tender

**8.2** The relevant details of the required goods and services, the terms, conditions and procedure for tendering, tender evaluation, placement of contract, the applicable contract terms and, also, the standard formats to be used for this purpose are incorporated in the above-mentioned documents. The interested tenderers are expected to examine all such details etc to proceed further.

## **9. Amendments to TE documents**

**9.1** At any time prior to the deadline for submission of tenders, the purchaser may, for any reason deemed fit by it, modify the TE documents by issuing suitable amendment(s) to it.

**9.2** Such an amendment will be notified only online through E-procurement ([www.bheleps.buyjunction.in](http://www.bheleps.buyjunction.in)) along with amendment notifications on BHEL ([www.bhel.com](http://www.bhel.com)) / government ([www.tenders.gov.in](http://www.tenders.gov.in)) tenders website.

**9.3** In order to provide reasonable time to the prospective tenderers to take necessary action in preparing their tenders as per the amendment, the purchaser may, at its discretion extend the deadline for the submission of tenders and other allied time frames, which are linked with that deadline.

## **10. Clarification of TE documents**

**10.1** A tenderer requiring any clarification or elucidation on any issue of the TE documents may take up the same with the purchaser in writing. The purchaser will respond in writing to such request provided the same is received by the purchaser ON OR BEFORE THE PRE BID MEETING (unless otherwise specified in the SIT). Representation sent after the pre bid meeting date will not be taken into cognizance.

## **11. Documents Comprising the e-Tender**

11.1 The tender shall be submitted online ~~ONLY EXCEPT TENDER FEE & EMD (in physical form)~~ as mentioned below:

- (i) **Technical Bid** (Consisting of Eligibility Criteria & Technical Specifications viz. Product Specification Sheets/Brochures, OEM Certificate etc.) Bidders may name the files indicating the nature of content in pdf/zip format which would be required to be attached in e-tender.
- (ii) **Price Bid** (To be filled up in the Proforma, Signed, Stamped, and Scanned to pdf mode & attach under PRICE BID.

### **DO NOT'S**

Bidders are requested **NOT** to submit the hard copy of Financial Bid along with the physical form of tender. In case the hard copy of financial bid is submitted in physical form, the tender may be rejected. Also, uploading of the price bid in prequalification bid or technical bid may RESULT IN REJECTION of the tender.

### **A) Technical Tender (UN priced Tender)**

All Technical details (eg. Eligibility Criteria requested (as mentioned below)) should be attached in e-tendering module, failing which the tender stands invalid & may be REJECTED. Bidders shall furnish the following information along with technical tender (preferably in pdf format):

- ~~(i) Earnest money Deposit (EMD) furnished in accordance with GIT clause 16.1 alternatively, documentary evidence as per GIT clause 16.2 for claiming exemption from payment of earnest money.~~
- (ii) Technical Bid (without indicating any prices).
- (iii) Tenderer/Agent who quotes for goods manufactured by other manufacturer shall furnish Manufacturer's Authorization Form. While giving authorization

to agent, to quote on their behalf, manufacturer has to give the reasons for not quoting directly against this tender.

#### **B) Price Bid:**

1. Prices are to be quoted in the attached Price Bid format online on e-tender portal in pdf format & apply digital signature certificate.

2. The price should be quoted for the accounting unit indicated in the e-tender document.

Note: It is the responsibility of tenderer to go through the TE document to ensure furnishing all required documents in addition to above, if any. Any deviation would result in REJECTION of tender and would not be considered at a later stage at any cost by BHEL.

**11.2** A person signing (manually or digitally) the tender form or any documents forming part of the contract on behalf of another shall be deemed to warrantee that he has authority to bind such other persons and if, on enquiry, it appears that the persons so signing had no authority to do so, the purchaser may, without prejudice to other civil and criminal remedies, cancel the contract and hold the signatory liable for all cost and damages.

**11.3** A tender, which does not fulfil any of the above requirements and/or gives evasive information/reply against any such requirement, shall be liable to be ignored and rejected.

**11.4** In case of e-Tender, offer sent by fax/telex/cable/electronically shall be ignored.

#### **12. Tender currencies**

**12.1** The tenderer supplying indigenous goods or already imported goods shall quote only in Indian Rupees (INR).

**12.2** For imported goods if supplied directly from abroad, prices shall be quoted in any freely convertible currency say US Dollar, Euro, GBP or Japanese Yen. As regards price(s) for allied services, if any required with the goods, the same shall be quoted in Indian Rupees only (INR), if such services are to be performed /undertaken in India. Exchange rate for converting such offers to INR will as SBI TT selling rate as on the date of Technical/Un-priced bid opening date.

#### **13. Tender Prices**

**13.1** The Tenderer shall indicate on the Price bid format provided under Section VIII all the specified components of prices shown therein including the unit prices and total tender prices of the goods and services it proposes to supply against the requirement. All the columns shown in the price bid should be filled up as required. If any column does not apply to a tenderer, same should be clarified as "NA" by the tenderer.

**13.2** While filling up the columns of the Price Schedule, the following aspects should be noted for compliance:

**13.3.1** For domestic goods or goods of foreign origin located within India, the prices in the corresponding price schedule shall be entered separately in the following manner:

- a. The price of the goods, quoted ex-factory/ ex-showroom/ ex-warehouse/ off-the-shelf, as applicable, including all taxes and duties like sales tax, CST VAT, CENVAT, Custom Duty, Excise Duty etc. already paid or payable on the components and raw material used in the manufacture or assembly of the goods quoted ex-factory etc. or on the previously imported goods of foreign origin quoted ex-showroom etc;
- b. Any sales or other taxes and any duties including excise duty, which will be payable on the goods in India if the contract is awarded;
- c. Charges towards Packing & Forwarding, Inland Transportation, Insurance (local transportation and storage), and Loading & Unloading etc. would be borne by the Supplier from ware house to the consignee site.

**13.3.2** For goods offered from abroad, the prices in the corresponding price schedule shall be entered separately in the following manner:

- a. The price of goods quoted FOB/FCA port of shipment, as indicated in the List of Requirements and Price Schedule;
- b. Freight and insurance charges.
- c. The price of goods quoted CIP (name port of destination) in India as indicated in the List of Requirements, Price Schedule and Consignee List
- d. The charges for Insurance (local transportation and storage) would be extended and borne by the Supplier from ware house to the consignee site for a period including 3 months beyond date of delivery. Other local costs and Incidental costs, as specified in the List of Requirements and Price Schedule;
- e. The charges for Incidental Services, as in the List of Requirements and Price Schedule;

#### **13.4 Additional information and instruction on Duties and Taxes:**

**13.4.1** If the Tenderer desires to ask for excise duty, sales tax/VAT, Service Tax, Works Contract Tax etc. to be paid extra, the same must be specifically stated. In the absence of any such stipulation the price will be taken inclusive of such duties and taxes and no claim for the same will be entertained later.

#### **13.4.2 Excise Duty:**

- a) If reimbursement of excise duty is intended as extra over the quoted prices, the supplier must specifically say so also indicating the rate, quantum and nature of the duty applicable. In the absence of any such stipulation it will be presumed that the prices quoted are firm and final and no claim on account of excise duty will be entertained after the opening of tenders.
- b) If a Tenderer chooses to quote a price inclusive of excise duty and also desires to be reimbursed for variation, if any, in the excise duty during the time of supply, the tenderer must clearly mention the same and also indicate the rate and quantum of excise duty included in its price. Failure to indicate all such details in clear terms may result in rejection of that tender.
- c) Subject to sub clauses **13.4.2** (a) & (b) above, any change in excise duty upward/downward as a result of any statutory variation in excise duty taking place within contract terms shall be allowed to the extent of actual quantum of excise duty paid by the supplier. In case of downward revision in excise duty, the actual quantum of reduction of excise duty shall be reimbursed to the purchaser by the supplier. All such adjustments shall include all reliefs, exemptions, rebates, concession etc. if any obtained by the supplier.

#### **13.4.3 Sales Tax:**

If a tenderer asks for sales tax/ VAT, Service Tax and Works Contract Tax to be paid extra, the rate and nature of sales tax applicable should be shown separately. The sales tax / VAT, Service Tax and Works Contract Tax will be paid as per the rate at which it is liable to be assessed or has actually been assessed provided the transaction of sale is legally liable to sales tax / VAT, Service Tax and Works Contract Tax and is payable as per the terms of the contract. If any refund of Tax is received at a later date, the Supplier must return the amount forth-with to the purchaser.

**13.5.4 Octroi Duty and Local Duties & Taxes:** Normally, goods to be supplied to government departments against government contracts are exempted from levy of town duty, Octroi duty, terminal tax and other levies of local bodies. However, if such taxes/duties are applicable same shall be clearly mentioned in the price bid/offer.

**13.4.5 Customs Duty:** The Purchaser will pay the Customs duty wherever applicable provided was mentioned the price bid/offer.

#### **14. 14 Payment of Agency Commission to Indian Agent (for foreign purchase):**

- I. BHEL shall deal directly with foreign vendors, wherever required, for procurement of goods. However, if the foreign principal desires to avail of the services of an Indian agent, then the foreign principal should ensure compliance to regulatory guidelines - which require mandatory submission of an Agency Agreement.
- II. It shall be incumbent on the Indian agent and the foreign principal to adhere to the relevant
- III. Guidelines of Government of India, issued from time to time.
- IV. The Agency Agreement should specify the precise relationship between the foreign OEM / foreign principal and their Indian agent and their mutual interest in the business. All services to be rendered by agent/ associate, whether of general nature or in relation to the particular contract, must be clearly stated by the foreign supplier/ Indian agent. Any payment, which the agent or associate receives in India or abroad from the OEM, whether as commission or as a general retainer fee should be brought on record in the Agreement and be made explicit in order to ensure compliance to laws of the country.
- V. Any agency commission to be paid by BHEL to the Indian agent shall be in Indian currency only.
- VI. Tax deduction at source is applicable to the agency commission paid to the Indian agent as per the prevailing rules.
- VII. In the absence of any agency agreement, BHEL shall not deal with any Indian agent (authorized representatives / associate / consultant, or by whatever name called) and shall deal directly with the foreign principal only for all correspondence and business purposes.
- VIII. The supply and execution of the Purchase Order (including indigenous supplies/ service) shall be in the scope of the OEM/ foreign principal. The OEM/ foreign principal should submit their offer inclusive of all indigenous supplies/ services and evaluation will be based on 'total cost to BHEL'. In case OEM/ foreign principal recommends placement of order(s) towards indigenous portion of supplies/ services on Indian supplier(s)/ agent on their behalf, the credentials/ capacity/ capability of the Indian supplier(s)/ agent to make the supplies/ services shall be checked by BHEL as per the extant guidelines of Supplier Evaluation, Approval & Review Procedure (SEARP), before opening of price bids. It will be the responsibility of the OEM/ foreign principal to get acquainted with the evaluation requirements of Indian supplier/ agent as per SEARP available on [www.bhel.com](http://www.bhel.com) OR <http://vis.bheltry.co.in/olsa>.
- IX. The responsibility for successful execution of the contract (including indigenous supplies/ services) lies with the OEM/ foreign principal. All bank guarantees to this effect shall be in the scope of the OEM/ foreign principal.

**15. 15. Firm Price**

**15.1** Unless otherwise specified in the GIT, prices quoted by the tenderer shall remain firm and fixed during the currency of the contract and not subject to variation on any account.

**15.2** However, as regards taxes and duties, if any, chargeable on the goods and payable, will be paid extra as applicable on the date of dispatch.

**16. 16. Earnest Money Deposit (EMD)**

**16.1** Pursuant to GIT (i) the tenderer shall furnish along with its tender, earnest money for amount as shown in the List of Requirements. The earnest money is required to protect the purchaser against the risk of the tenderer's unwarranted conduct as amplified under sub-clause 16.7 below.

**16.2** The tenderers who are currently registered and, also, will continue to remain registered during the tender validity period with Directorate General of Supplies & Disposals or with National Small Industries Corporation, New Delhi for the specific goods as per tender enquiry specification shall be eligible for exemption from EMD. In case the tenderer falls in these

categories, it should furnish copy of its valid registration details (with DGS&D or NSIC, as the case may be).

**16.3** The earnest money shall be denominated in Indian Rupees or equivalent currencies as per GIT clause 12.2. The earnest money shall be furnished in one of the following forms:

- i) Account Payee Demand Draft
- ii) Banker's cheque and
- iii) Bank Guarantee

**16.4** The demand draft or banker's cheque shall be drawn on any commercial bank in India or country of the tenderer, in favour of the "Bharat Heavy Electricals Limited" payable at Trichy India. In case of bank guarantee, the same is to be provided from any commercial bank in India or country of the tenderer as per the format specified under Section XI in these documents.

**16.5** The earnest money shall be valid for a period of forty-five (45) days beyond the validity period of the tender. As validity period of Tender as per Clause 17 of GIT is 60 days, the EMD shall be valid for 105 days from Techno – Commercial Tender opening date.

**16.6** Unsuccessful tenderers' earnest money will be returned to them without any interest, after expiry of the tender validity period, but not later than thirty days after conclusion of the resultant contract. Successful tenderer's earnest money will be returned without any interest, after receipt of performance security from that tenderer.

**16.7** Earnest Money is required to protect the purchaser against the risk of the Tenderer's conduct, which would warrant the forfeiture of the EMD. Earnest money of a tenderer will be forfeited, if the tenderer withdraws or amends its tender or impairs or derogates from the tender in any respect within the period of validity of its tender or if it comes to notice that the information/documents furnished in its tender is incorrect, false, misleading or forged without prejudice to other rights of the purchaser. The successful tenderer's earnest money will be forfeited without prejudice to other rights of Purchaser if it fails to furnish the required performance security within the specified period.

**16.8** In the case of Bank Guarantee furnished from banks outside India (i.e. foreign Banks), it should be authenticated and countersigned by any nationalized bank in India by way of back-to-back counter guarantee and the same should be submitted along with the bid.

## **17. Tender Validity**

**17.1** If not mentioned otherwise in the GIT, the tenders shall remain valid for acceptance for a period of 60 days (Sixty days) after the date of tender opening prescribed in the TE document. Any tender valid for a shorter period shall be treated as unresponsive and rejected.

**17.2** In exceptional cases, the tenderers may be requested by the purchaser to extend the validity of their tenders up to a specified period. Such request(s) and responses thereto shall be conveyed by e-mail/EPN message or by fax/ telex/cable. The tenderers, who agree to extend the tender validity, are to extend the same without any change or modification of their original tender and they are also to extend the validity period of the EMD accordingly. A tenderer, who may not agree to extend its tender validity after the expiry of the original validity period the EMD furnished by them shall not be forfeited.

**17.3** In case the day up to which the tenders are to remain valid falls on/ subsequently declared a holiday or closed day for the purchaser, the tender validity shall automatically be extended up to the next working day.

## **18. Digital Signing of e-Tender**

**18.1** The tenderers shall submit their tenders as per the instructions contained in GIT Clause 11. Tenders shall be uploaded with all relevant PDF/zip format. The relevant tender documents should be uploaded by an authorized person having Class 3- SHA2- 2048 BIT-SIGNING & ENCRYPTION digital signature certificate (DSC).

**19. Submission of Tenders**

**19.1** The tender shall be submitted online only at <https://bheleps.buyjunction.in>.

**(i) Pre-qualification and Technical compliance** as per following documents (ONLY Online submissions for all the documents.)

- a) Manufacturer's authorization in case bid is submitted by an Indian agent (A declaration must be attached here in case directly quoted by a manufacturer or a document establishing the relation of the Indian office with the manufacturer in case quoted by Indian office of the manufacturer).
- b) Tender Form as per section VII.
- c) Compliance of all terms and conditions of TED like- warranty, delivery period, delivery terms, payment terms etc
- d) Declaration regarding Fall Clause and Deregistration, debarment from any Govt. Dept/ Agencies

**(ii) PRICE BID (ONLY ONLINE).**

**19.2** The tenderers must ensure that they submit the on-line tenders not later than the closing time.

**20. Late Tender**

**20.1** There is NO PROVISION of uploading late tender beyond stipulated date & time in the e-tendering system.

**21. Alteration and Withdrawal of Tender**

**21.1** The tenderer, is permitted to change, edit or withdraw it's bid on or before the end date & time only.

**22. Opening of Tenders**

**22.1** The purchaser will open the e-tenders at the specified date and time and at the specified place as indicated in the NIT. In case the specified date of tender opening falls on / is subsequently declared a holiday or closed day for the purchaser, the tenders will be opened at the appointed time and place on the next working day.

**22.2** Authorized representatives of the tenderers, who have submitted tenders on time may attend the tender opening provided they bring with them letters of authority from the corresponding tenderers.

**22.3** Two - Tender system will be as follows. The Techno - Commercial Tenders are to be opened in the first instance, at the prescribed time and date as indicated in NIT. These Tenders shall be scrutinized and evaluated by the competent committee/ authority with reference to parameters prescribed in the TE document. ~~During the Techno - Commercial Tender opening, the tender opening official(s) will read the salient features of the tenders like brief description of the goods offered, delivery period, Earnest Money Deposit and any other special features of the tenders, as deemed fit by the tender opening official(s).~~ Thereafter, in the second stage, the Price Tenders of only the Techno - Commercially acceptable offers (as decided in the first stage) shall be opened for further scrutiny and evaluation on a date notified after the evaluation of the Techno - Commercial tender. The prices, special discount if any of the goods offered etc., as deemed fit by tender opening official(s) will be read out.

**23. Basic Principle for Tender evaluation**

**23.1** Tenders will be evaluated on the basis of the terms & conditions already incorporated in the TE document, based on which tenders have been received and the terms, conditions etc.

mentioned by the tenderers in their tenders. No new condition will be brought in while scrutinizing and evaluating the tenders.

**24. Scrutiny of Tenders**

**24.1** The Purchaser will examine the Tenders to determine whether they are complete, whether any computational errors have been made, whether required sureties have been furnished, whether the documents have been properly signed stamped and whether the Tenders are generally in order.

**25. Discrepancies in Prices**

- i If, in the price structure quoted for the required goods! services works, there is discrepancy between the unit price and the total price (which is obtained by multiplying the unit price by the quantity), the unit price shall prevail and the total price corrected accordingly, unless in the opinion of the purchaser there is an obvious misplacement of the decimal point in the unit price, in which case the total price as quoted shall govern and the unit price corrected accordingly.
- ii If there is an error in a total corresponding to the addition or subtraction of subtotals, the subtotals shall prevail and the total shall be corrected; and
- iii If there is a discrepancy between words and figures, the amount in words shall prevail, unless the amount expressed in words is related to an arithmetic error, in which case the amount in figures shall prevail subject of (i) and (ii) above.
- iv If there is such discrepancy in an offer, the same shall be conveyed to the bidder with target date upto which the bidder has to send his acceptance on the above lines and if the bidder does not agree to the decision of the purchaser, the bid is liable to be ignored.

**SECTION - III****GENERAL CONDITIONS OF CONTRACT (GCC)****26. 1. Application**

**26.1** The General Conditions of Contract incorporated in this section shall be applicable for this purchase to the extent the same are not superseded by any Special Conditions of Contract prescribed anywhere in this TE document.

**27. Use of contract documents and information**

**27.1** The supplier shall not, without the purchaser's prior written consent, disclose the contract or any provision thereof including any specification, drawing, sample or any information furnished by or on behalf of the purchaser in connection therewith, to any person other than the person(s) employed by the supplier in the performance of the contract emanating from this TE document. Further, any such disclosure to any such employed person shall be made in confidence and only so far as necessary for the purposes of such performance for this contract.

**27.2** Further, the supplier shall not, without the purchaser's prior written consent, make use of any document or information mentioned in GCC sub-clause 27.1 above except for the sole purpose of performing this contract.

**27.3** Except the contract issued to the supplier, each and every other document mentioned in GCC sub-clause 27.1 above shall remain the property of the purchaser and, if advised by the purchaser, all copies of all such documents shall be returned to the purchaser on completion of the supplier's performance and obligations under this contract.

**28. Patent Rights**

**28.1** The supplier shall, at all times, indemnify and keep indemnified the purchaser, free of cost, against all claims which may arise in respect of goods & services to be provided by the supplier under the contract for infringement of any intellectual property rights or any other right protected by patent, registration of designs or trademarks. In the event of any such claim in respect of alleged breach of patent, registered designs, trademarks etc. being made against the purchaser, the purchaser shall notify the supplier of the same and the supplier shall, at his own expenses take care of the same for settlement without any liability to the purchaser.

**29. Country of Origin**

**29.1** All goods and services to be supplied and provided for the contract shall have the origin in India or in the countries with which the Government of India has trade relations.

**29.2** The word "origin" incorporated in this clause means the place from where the goods are mined, cultivated, grown, manufactured, produced or processed or from where the services are arranged.

**29.3** The country of origin may be specified in the Price bid format.

**30. Technical Specifications and Standards**

**30.1** The Goods & Services to be provided by the supplier under this contract shall conform to the technical specifications and quality control parameters mentioned in „Technical Specification and „Quality Control Requirements as mentioned in this document.

**31. Packing and Marking**

**31.1** The packing for the goods to be provided by the supplier should be strong and durable enough to withstand, without limitation, the entire journey during transit including transshipment (if any), rough handling, open storage etc. without any damage, deterioration etc. As and if necessary, the size, weights and volumes of the packing cases shall also take into consideration, the remoteness of the final destination of the goods and availability or otherwise of transport and handling facilities at all points during transit up to final destination as per the contract.

**31.2** The quality of packing, the manner of marking within & outside the packages and provision of accompanying documentation shall strictly comply with the requirements as provided in Technical Specifications and Quality Control Requirements. In case the packing requirements are amended due to issue of any amendment to the contract, the same shall also be taken care of by the supplier accordingly.

**31.3** Packing instructions: Unless otherwise mentioned in the Technical Specification and Quality Control Requirements, the supplier shall make separate packages for each consignee (in case there is more than one consignee mentioned in the contract) and mark each package on three sides with the following with indelible paint of proper quality:

- a. Purchase Order number and date
- b. brief description of goods including quantity
- c. packing list reference number
- d. country of origin of goods
- e. consignees name and full address and
- f. suppliers name and address
- g. Any other information as per Purchase order/dispatch instructions.

## **32. Inspection, Testing and Quality Control**

**32.1** Goods/Materials shall be made ready as per the specifications mentioned in the purchase order and approved quality plan shall be followed in each stage of manufacturing the ordered materials. Ready materials shall be inspected by BHEL/BHEL TPI/ NTPC or BHEL Customer as per the purchase order. Tenderer shall inform well in advance the readiness of the materials so that the purchaser can arrange for Inspection, Testing and Quality evaluation of the ready materials.

**32.2** Goods accepted by the purchaser/consignee and/or its inspector at initial inspection and in final inspection in terms of the contract shall in no way dilute purchaser's/consignee's right to reject the same later, if found deficient in terms of the warranty clause of the contract, as incorporated under GCC Clause 34.

## **33. Terms of Delivery**

**33.1** Goods shall be delivered by the supplier in accordance with the terms of delivery and as per the delivery period specified in the schedule of requirement. Please note that the time shall be the essence of the contract.

## **34. WARRANTY**

**34.1** The supplier warrants comprehensively that the goods supplied under the contract is new, unused and incorporate all recent improvements in design and materials unless prescribed otherwise by the purchaser in the contract. The supplier further warrants that the goods supplied under the contract shall have no defect arising from design, materials, manufacturing or workmanship or from any act or omission of the supplier that may develop under normal use of the supplied goods under the conditions prevailing in India.

**34.2** The warranty shall remain valid for the period as mentioned in the list of requirement/ General Technical specification, after the goods or any portion thereof as the case may be, have been delivered, installed and commissioned at the final destination.

- a. No conditional warranty will be acceptable.
- b. Replacement and repair will be under taken for the defective goods.
- c. Proper marking has to be made for all spares for identification like printing of installation and repair dates.

**34.3** In case of any claim arising out of this warranty, the Purchaser/Consignee shall promptly notify the same in writing to the supplier. The period of the warranty will be as per G.C.C clause number 34.2 above irrespective of any other period mentioned elsewhere in the bidding documents.

**34.4** Upon receipt of such notice, the supplier shall, within 8 hours on a 24(hrs) X 7 (days) X 365 (days) basis respond to take action to repair or replace the defective goods or parts thereof, free of cost, at the ultimate destination. The supplier shall take over the replaced parts/goods after providing their replacements and no claim, whatsoever shall lie on the purchaser for such replaced parts/goods thereafter. The penalty clause for non-rectification will be applicable as per tender conditions

**34.5** In the event of any rectification of a defect or replacement of any defective goods during the warranty period, the warranty for the rectified/replaced goods shall be extended till the completion of the original warranty period of the main equipment.

**34.6** If the supplier, having been notified, fails to respond to take action to repair or replace the defect(s) within 8 hours on a 24(hrs) X 7 (days) X 365 (days) basis, the purchaser may proceed to take such remedial action(s) as deemed fit by the purchaser, at the risk and expense of the supplier and without prejudice to other contractual rights and remedies, which the purchaser may have against the supplier.

**34.7** During Warranty period, the supplier is required to visit at each consignee's site at least once in 6 months commencing from the date of the installation for preventive maintenance of the goods (if required).

## **35. ASSIGNMENT**

**35.1** The Supplier shall not assign, either in whole or in part, its contractual duties, responsibilities and obligations to perform the contract, except with the Purchaser's prior written permission.

## **36. PRICES**

**36.1** Prices to be charged by the supplier for supply of goods and provision of services in terms of the contract shall not vary from the corresponding prices quoted by the supplier in its tender and incorporated in the contract.

## **37. TAXES AND DUTIES**

**20.1** Supplier shall be entirely responsible for all taxes, duties, fees, levies etc. incurred until delivery of the contracted goods to the purchaser.

## **38. TERMS AND MODE OF PAYMENT**

### **38.1 Payment Terms**

Payment shall be made subject to recoveries, if any, by way of liquidated damages or any other charges as per terms & conditions of contract in the following manner.

#### **For Indian Vendors –**

- a. Payment term is 100% direct payment after 45 days from the date of dispatch against site acknowledgement. (or)
- b. Payment term is 90% direct payment after 45 days from the date of dispatch against submission of dispatch documents and balance 10% against site acknowledgement. For this option –(b), a loading of 2% on the 90% of the offered value shall be made.

**For Foreign Vendors –**

BHEL Payment term is 100% payment on CAD basis after 45 days from the date of receipt of documents, specified in PO, at BHEL bank. Respective bank charges to respective account.

Any deviation in the above payment term will attract loading as mentioned below.

“Base rate of SBI (as applicable on the date of bid opening. Techno-commercial bid opening in case of two part bids) + 6% shall be considered for loading for the period of relaxation sought by bidders.

- a. In the case of Usance LCs the loading will be considered @ 1.5% on the offered Value.
- b. For LC at sight the loading will be considered @ 3.5% on the offered Value.
- c. Normally CAD at sight and Confirmed LCs are liable for rejection.

**39. Delivery**

**39.1** The supplier shall deliver the goods and perform the services under the contract within the time schedule specified by the Purchaser/Consignee in the List of Requirements and as incorporated in the contract. The time for and the date of delivery of the goods stipulated in the schedule shall be deemed to be of the essence of the contract and the delivery must be completed not later than the date (s) as specified in the contract.

**39.2** Subject to the provision under GCC clause 26, any unexcused delay by the supplier in maintaining its contractual obligations towards delivery of goods and performance of services shall render the supplier liable to any or all of the following sanctions:

- (i) imposition of liquidated damages,
- (ii) forfeiture of its performance security and
- (iii) Termination of the contract for default.

**39.3** If at any time during the currency of the contract, the supplier encounters conditions hindering timely delivery of the goods and performance of services, the supplier shall promptly inform the Purchaser/Consignee in writing about the same and its likely duration and make a request to the Purchaser/Consignee for extension of the delivery schedule accordingly. On receiving the supplier's communication, the Purchaser/Consignee shall examine the situation as soon as possible and, at its discretion, may agree to extend the delivery schedule, with or without liquidated damages for completion of supplier's contractual obligations by issuing an amendment to the contract.

**39.4** When the period of delivery is extended due to unexcused delay by the supplier, the amendment letter extending the delivery period shall, inter alia contain the following conditions:

**(a)** The Purchaser/Consignee shall recover from the supplier, under the provisions of the clause 40 of the General Conditions of Contract, liquidated damages on the goods and services, which the Supplier has failed to deliver within the delivery period stipulated in the contract.

**(b)** That no increase in price on account of any ground, whatsoever, including any stipulation in the contract for increase in price on any other ground and, also including statutory increase in or fresh imposition of customs duty, excise duty, sales tax/ VAT, Service Tax and Works Contract Tax or on account of any other tax or duty which may be levied in respect of the goods and services specified in the contract, which takes place after the date of delivery stipulated in the contract shall be admissible on such of the said goods and services as are delivered and performed after the date of the delivery stipulated in the contract.

**(c)** But nevertheless, the Purchaser/Consignee shall be entitled to the benefit of any decrease in price on account of reduction in or remission of customs duty, excise duty, sales tax/ VAT, Service Tax and Works Contract Tax or any other duty or tax or levy or on account of any other grounds, which takes place after the expiry of the date of delivery stipulated in the contract.

**39.5** The supplier shall not dispatch the goods after expiry of the delivery period. The supplier is required to apply to the Purchaser/Consignee for extension of delivery period and obtain

the same before dispatch. In case the supplier dispatches the goods without obtaining an extension, it would be doing so at its own risk and no claim for payment for such supply and / or any other expense related to such supply shall lie against the purchaser.

#### **40. LIQUIDATED DAMAGES**

**40.1** Subject to GCC clause 26, if the supplier fails to deliver or install /commission any or all of the goods or fails to perform the services within the time frame(s) incorporated in the contract, the Purchaser/Consignee shall, without prejudice to other rights and remedies available to the Purchaser/Consignee under the contract, deduct from the contract price, as liquidated damages, a sum equivalent to 0.5% per week of delay or part thereof on total order value of goods, installation, commissioning and/or services until actual delivery or performance subject to a maximum of 10% of the contract price. Once the maximum is reached Purchaser/Consignee may consider termination of the contract as per GCC 41. During the above-mentioned delayed period of supply and / or performance, the conditions incorporated under GCC sub-clause 39.4 above shall also apply.

#### **41. TERMINATION FOR DEFAULT**

**41.1** The Purchaser/Consignee, without prejudice to any other contractual rights and remedies available to it (the Purchaser/Consignee), may, by written notice of default sent to the supplier, terminate the contract in whole or in part, if the supplier fails to deliver any or all of the goods or fails to perform any other contractual obligation(s) within the time period specified in the contract, or within any extension thereof granted by the Purchaser/Consignee pursuant to GCC sub-clauses 39.

**41.2** In the event of the Purchaser/Consignee terminates the contract in whole or in part, pursuant to GCC sub-clause 41.1 above, the Purchaser/Consignee may procure goods and/or services similar to those cancelled, with such terms and conditions and in such manner as it deems fit and the supplier shall be liable to the Purchaser/Consignee for the extra expenditure, if any, incurred by the Purchaser/Consignee for arranging such procurement.

**41.3** Unless otherwise instructed by the Purchaser/Consignee, the supplier shall continue to perform the contract to the extent not terminated.

#### **42. FORCE MAJEURE**

**42.1** Notwithstanding the provisions contained in GCC clauses 39, 40 and 41, the supplier shall not be liable for imposition of any such sanction so long the delay and/or failure of the supplier in fulfilling its obligations under the contract is the result of an event of Force Majeure.

**42.2** For purposes of this clause, Force Majeure means an event beyond the control of the supplier and not involving the supplier's fault or negligence and which is not foreseeable and not brought about at the instance of , the party claiming to be affected by such event and which has caused the non – performance or delay in performance. Such events may include, but are not restricted to, wars or revolutions, hostility, acts of public enemy, civil commotion, sabotage, fires, floods, explosions, epidemics, quarantine restrictions, strikes excluding by its employees , lockouts excluding by its management, freight embargoes and Acts of God.

**42.3** If a Force Majeure situation arises, the supplier shall promptly notify the Purchaser/Consignee in writing of such conditions and the cause thereof within twenty one days of occurrence of such event. Unless otherwise directed by the Purchaser/Consignee in writing, the supplier shall continue to perform its obligations under the contract as far as reasonably practical, and shall seek all reasonable alternative means for performance not prevented by the Force Majeure event.

**42.4** If the performance in whole or in part or any obligation under this contract is prevented or delayed by any reason of Force Majeure for a period exceeding sixty days, either party may at its option terminate the contract without any financial repercussion on either side.

**42.5** In case due to a Force Majeure event the Purchaser/Consignee is unable to fulfil its contractual commitment and responsibility, the Purchaser/Consignee will notify the supplier accordingly and subsequent actions taken on similar lines described in above sub-paragraphs.

#### **43. TERMINATION FOR CONVENIENCE**

**43.1** The Purchaser/Consignee reserves the right to terminate the contract, in whole or in part for its (Purchaser's/Consignee's) convenience, by serving written notice on the supplier at any time during the currency of the contract. The notice shall specify that the termination is for the convenience of the Purchaser/Consignee. The notice shall also indicate interalia, the extent to which the supplier's performance under the contract is terminated, and the date with effect from which such termination will become effective.

**43.2** The goods and services which are complete and ready in terms of the contract for delivery and performance before the supplier's receipt of the notice of termination shall be accepted by the Purchaser/Consignee following the contract terms, conditions and prices. For the remaining goods and services, the Purchaser/Consignee may decide:

- a) To get any portion of the balance completed and delivered at the contract terms, conditions and prices; and / or
- b) To cancel the remaining portion of the goods and services and compensate the supplier by paying an agreed amount for the cost incurred by the supplier towards the remaining portion of the goods and services.

#### **44. GOVERNING LANGUAGE**

**44.1** The contract shall be written in English language following the provision as contained in GIT clause 4. All correspondence and other documents pertaining to the contract, which the parties exchange, shall also be written accordingly in that language.

#### **45. Notices**

**45.1** Notice, if any, relating to the contract given by one party to the other, shall be sent in writing or by cable or telex or facsimile and confirmed in writing. The procedure will also provide the sender of the notice, the proof of receipt of the notice by the receiver. The addresses of the parties for exchanging such notices will be the addresses as incorporated in the contract.

**45.2** The effective date of a notice shall be either the date when delivered to the recipient or the effective date specifically mentioned in the notice, whichever is later.

#### **46. RESOLUTION OF DISPUTES**

**46.1** If dispute or difference of any kind shall arise between the Purchaser/Consignee and the supplier in connection with or relating to the contract, the parties shall make every effort to resolve the same amicably by mutual consultations.

**46.2** If the parties fail to resolve their dispute or difference by such mutual consultation within 30 days of its occurrence, then, unless otherwise provided in the contract, either the Purchaser/Consignee or the supplier may give notice to the other party of its intention to commence arbitration, as hereinafter provided the applicable arbitration procedure will be as per the Arbitration and Conciliation Act, 1996 of India. In the case of a dispute or difference arising between the Purchaser/Consignee and a domestic Supplier relating to any matter arising out of or connected with the contract, such dispute or difference shall be referred to the sole arbitration of an officer in BHEL Trichy, appointed to be the arbitrator by the General Manager/MM/RM BHEL Trichy. The award of the arbitrator shall be final and binding on the parties to the contract.

**46.3** Venue of Arbitration: The venue of arbitration shall be the place from where the contract has been issued, i.e., BHEL Trichy.

**46.4** Jurisdiction of the court will be from the place where the tender enquiry document has been issued, i.e., Trichy India

**47. APPLICABLE LAW**

The contract shall be governed by and interpreted in accordance with the laws of India for the time being in force.

**48. Withholding and Lien in respect of sums claimed**

Whenever any claim for payment arises under the contract against the supplier the purchaser shall be entitled to withhold and also have a lien to retain such sum from the security deposit or sum of money arising out of under any other contract made by the supplier with the purchaser, pending finalization or adjudication of any such claim. It is an agreed term of the contract that the sum of money so withheld or retained under the lien referred to above, by the purchaser, will be kept withheld or retained till the claim arising about of or under the contract is determined by the Arbitrator or by the competent court as the case may be, and the supplier will have no claim for interest or damages whatsoever on any account in respect of such withholding or retention.

**49. Replacement of defective work or material**

If during the progress of the work, the Purchaser or his representative shall decide and notify in writing to the contractor that the contractor has executed any unsound or imperfect work or has supplied any plant or material inferior in quantity or quality to those specified, the contractor on defects or deficiency shall, at his own expense, within fifteen days' of his receiving the notice, or otherwise within such time as may be reasonably necessary for making in good, proceed to alter, reconstruct, or remove such work, or supply fresh materials up to the standard of the particulars and in case the Contractor shall fail to do so, the Purchaser may, on giving the Contractor fifteen days' notice in writing of his intention to do so, proceed to remove the work or materials complained of, and at the cost of the Contractor perform all such work or supply all such materials, provided that nothing in this clause shall be deemed to deprive the purchaser of or affect, any rights under the contract which he may otherwise have in respect of such defects or deficiencies. BHEL reserves the discretion to levy storage charges for material not lifted within the reasonable period.

**50. Rectification of Defects**

Any defects which in the opinion of the Inspector may be apparent after erection and testing as mentioned in the specification, shall be rectified by the Contractor to the satisfaction of the Inspector at the expense of the Contractor and it shall be in his power to direct that further test shall be made at the expense of the Contractor after the said defects have been rectified to the satisfaction of the Inspector. If, after a reasonable time for rectifying defects shall have been allowed to the contractor the Inspector shall be of opinion that the defect cannot satisfactorily be rectified, and that the material/component/machinery supplied is unsuited for or incapable of performing the work required, the Purchaser may, if he shall think fit (without prejudice, and in addition to any other remedy he may have in the premises) determine this contract, and thereupon all money paid to the Contractor under the contract in respect thereof shall upon demand be repaid by them to the purchaser, and they shall be liable for all damages heretofore provided for non-fulfilment of contract

**51. SECRECY**

The contractor shall take all reasonable steps necessary to ensure that all persons employed in any work in connection with the contract, have full knowledge of the Official Secrets Act and any Regulations framed thereunder. Any information obtained in the course of the execution

of the contract by the contractor, his servants or Agents or any person so employed, as to any matter whatsoever; which would or might be directly or indirectly of use to any competitor of BHEL or enemy of India must be treated as Secret and shall not at any time be communicated to any person. Any breach of the aforesaid condition shall entitle BHEL to cancel the contract and to purchase or authorize the purchase of the materials/goods at the risk and cost of the contractor invoking risk purchase clause.

**52. Fraud Prevention**

The bidder along with its associate / collaborators / sub-contractors / sub-vendors/consultants/service providers shall strictly adhere to BHEL Fraud prevention Policy displayed on BHEL website <http://www.bhel.com> and shall immediately bring to the notice of BHEL Management about any fraud or suspected fraud as soon as it comes to their notice.

**53. Vendor Works/Location**

Vendors having multiple works/locations shall indicate in the technical bid the location from where there are going execute the order if placed, and the said works/location must be approved by BHEL/BHEL customer as may be the case.

**54. GENERAL/ MISCELLANEOUS CLAUSES**

- i Any Purchase Order resulting from this enquiry shall be governed by these general terms and conditions listed above (1-53) and special terms and conditions, if any, along with this enquiry of Bharat Heavy Electricals Limited, BHEL HPBP, Trichy-620014 (hereinafter referred to as BHEL Trichy).
- ii Any of the terms and conditions not acceptable to supplier, shall be explicitly mentioned in the quotation. Otherwise, it will be treated as that all terms and conditions of this enquiry are acceptable.
- iii If counter terms and conditions are offered by supplier, BHEL Trichy shall not be governed by such terms and conditions, unless it is agreed and incorporated in the Purchase Order of BHEL Trichy.
- iv Any deviation to the terms and conditions not mentioned in the quotation by supplier in response to this enquiry will not be considered, if put forth subsequently or after issue of order, unless clarification is sought for by BHEL TRICHY and agreed upon in the Purchase Order of BHEL TRICHY.
- v BHEL TRICHY reserves the right to adopt Reverse Auction for the enquiry sent, at its discretion.
- vi BHEL TRICHY shall be at liberty to cancel the tender at any time, before ordering, without assigning any reason.
- vii The correspondence exchanged against the tender from both tenderer and BHEL through email are considered as valid document legally though it is not signed. It is treated as valid confirmations made on behalf of the respective company and very much comes under the legal ambit of the business transaction and hence it is binding on both the parties to the business.
- viii Banned Firms - The offers of the bidders who are on the banned list as also the offer of the bidders, who engage the services of the banned firms, shall be rejected. The list of banned firms is available on BHEL website [www.bhel.com](http://www.bhel.com).
- ix Bidders participating in the tender should declare in their technical bid that whether they have been black-listed / kept on hold for a specified period / given Business

holiday for a specified period by any Public sector undertaking or Government departments. The reasons for such action with details and the current status of such hold shall be clearly furnished to BHEL. If no such details are mentioned in the offer then it will be construed that the subject bidder is not under any such hold. But at a later date if it comes to the notice of BHEL about any such hold under enforcement on the subject bidder, BHEL will have every right to reject the offer of such vendors at any point of time and also under any stage of the finalization of the subject tender irrespective of the status of the subject bidder in that tender. Such bidders will not be permitted to participate in the further tender proceedings and will be communicated suitably. They will not be also considered for any ongoing tenders even if participated till the hold is officially lifted and confirmed in writing.

- x Risk purchase: - If the supplier fails to deliver the goods within the delivery specified in the Purchase Order, BHEL will be entitled to terminate the contract and to purchase elsewhere at the risk and cost of the seller either the whole of the goods or any part which the supplier has failed to deliver or dispatch within the delivery period mentioned in the Purchase Order.
- xi The court of the place from where the purchase order is issued shall alone have jurisdiction to decide any dispute arising out of or in connection with the purchase order.
- xii Cartel Formation: - All the firms should desist from forming cartel as the practice is prohibited under Section 3(3) (a) & (d) of the competition Act 2002. If any such instance is observed during this tender will attract disciplinary action as per BHEL policies.

**SECTION – IV****SPECIAL CONDITIONS OF CONTRACT (SCC)**

1. Price may be finalized thro “On line Reverse Auction Process” using internet. BHEL reserves the right to go for Reverse Auction (RA) instead of opening the sealed envelope price bid, submitted by the bidder. This will be decided after techno-commercial evaluation. All bidders to give their acceptance for participation in RA. Non-acceptance to participate in RA may result in non-consideration of their bids, in case BHEL decides to go for RA.  
In case BHEL decides to go for Reverse Auction, only those bidders who have given their acceptance to participate in RA will be allowed to participate in the Reverse Auction. Those bidders who have given their acceptance to participate in Reverse Auction will have to necessarily submit online sealed bid” in the Reverse Auction. Non submission of online sealed bid” by the bidder will be considered as tampering of the tender process and will invite action by BHEL as per extant guidelines in vogue. **Refer section IX for details.**
2. Loading of Price Bids – Loading will be applicable for any deviations taken by **tenderer as per Section XI** to this TE document.
3. **Testing and Inspection by BHEL for indigenous supply.**
4. **Confirmation to BHEL specifications TFS:1001A/Rev.02 and as per drawing 4-45-320-01618A, 3-45-000-01273A/Var 03, 3-45-000-01283A/Var 08 & 3-45-000-01283A/Var 09 (as per enquiry)**
5. MSE Clause is applicable as per **Section XIV**

**SECTION – V****List of Requirements****PART - I**

Sr. No	Item	Qty (Nos)
<b>Package 1</b>	Graphite Alloy Bearing & Bushing as per specifications TFS:1001A/Rev.02 and as per drawing 4-45-320-01618A, 3-45-000-01273A/Var 03, 3-45-000-01283A/Var 08 & 3-45-000-01283A/Var 09	1864 nos

**PART – II Required Delivery Schedule:**

- i. To be delivered by 24.04.2016.

**PART – III Delivery Location**

Materials shall be delivered at Ward 26, BHEL Trichy Stores.

**PART – IV Guarantee**

18 months from the date of receipt and acceptance of materials at BHEL Trichy stores.

**PART – V Delivery Terms**

For Indigenous vendors – FOR BHEL Trichy stores.

For Vendors – CIF Chennai basis

**SECTION – VI****Technical and Quality Specifications**

Materials shall be manufactured as per specifications TFS:1001A/Rev.02 and as per drawing 4-45-320-01618A, 3-45-000-01273A/Var 03, 3-45-000-01283A/Var 08 & 3-45-000-01283A/Var 09 attached to this tender enquiry document.

Sr. No	Item	Qty (nos)
<b>1</b>	Damper Bearing	488
<b>2</b>	Bushing Var 03	400
<b>3</b>	Bushing Var 08	488
<b>4</b>	Bushing Var 09	488
<b>TOTAL</b>		<b>1864</b>

Tender will be evaluated on item wise cost to BHEL.

**SECTION – VII**

**Tender Form**

**(to be submitted on company letterhead)**

To

GM/MM/RM

BHEL Trichy

Ref. Your TE document No. 1801501116 dated 01.10.2015

We, the undersigned have examined the above mentioned TE document, including amendment/corrigendum No. \_\_\_\_\_, dated \_\_\_\_\_ (if any), the receipt of which is hereby confirmed.

We now offer to supply and deliver \_\_\_\_\_ (Description of goods and services) in conformity with your above referred document for the sum as shown in the price schedules attached herewith and made part of this tender. If our tender is accepted, we undertake to supply the goods and perform the services as mentioned above, in accordance with the delivery schedule specified in the List of Requirements. We further confirm that, if our tender is accepted, we shall provide you with a performance security of required amount in an acceptable form in terms of GCC clause 34, read with modification, if any, in Section - IV – “Special Conditions of Contract”, for due performance of the contract.

We agree to keep our tender valid for acceptance as required in the GIT clause 17, read with modification, if any as per clause 9 of GIT or for subsequently extended period, if any, agreed to by us. We also accordingly confirm to abide by this tender up to the aforesaid period and this tender may be accepted any time before the expiry of the aforesaid period.

We further confirm that, until a formal contract is executed, this tender read with your written acceptance thereof within the aforesaid period shall constitute a binding contract between us. We further understand that you are not bound to accept the lowest or any tender you may receive against your above-referred tender enquiry. We confirm that we do not stand deregistered/banned/blacklisted by any (GOI) Govt. Authorities/PSUs.

We confirm that we fully agree to the terms and conditions specified in above mentioned TE document, including amendment/ corrigendum if any

(Signature with date)

(Name and designation)

**SECTION – VIII****Price bid Formats****For Indian Vendors**

Sr. No	Item (A)	Qty (nos) (B)	Rate/unit (C)	Basic Amt = BxC (D)	EXCISE DUTY on D (E)	CST/VAT on D+E (F)	Freight (G)	Insur 0.07% of D+E+G (F)	Total Amount D+E+G+F
1	Damper Bearing	488							
2	Bushing Var 03	400							
3	Bushing Var 08	488							
4	Bushing Var 09	488							
	<b>TOTAL</b>	<b>1864</b>							

**For Foreign Vendors**

Sr. No	Item (A)	Qty (nos) (B)	FOB price/nos (C)	FOB Amount = BxC (D)	Freight to Chennai port (E)	Any other charges (F)	CIF Chennai Port Amt. (G)
1	Damper Bearing	488					
2	Bushing Var 03	400					
3	Bushing Var 08	488					
4	Bushing Var 09	488					
	<b>TOTAL</b>	<b>1864</b>					

For imports custom duty, handling charges, transportation & other charges from Chennai port to BHEL Trichy will added to price bids of foreign vendors during price evaluation.

**\*\*One copy of this format to be attached with technical bid without prices mentioning ED, CST/VAT & Freight as percentages of Basic cost.**

## **SECTION – IX**

### **Reverse Auction**

Against this enquiry for the subject item/ system with detailed scope of supply as per Tender enquiry specifications, BHEL may resort to “REVERSE AUCTION PROCEDURE” i.e ON LINE BIDDING (THROUGH A SERVICE PROVIDER). The philosophy followed for reverse auction shall be English Reverse (No ties).

1. For the proposed reverse auction, technically and commercially acceptable bidders only shall be eligible to participate.
2. Those bidders who have given their acceptance for Reverse Auction (quoted against this tender enquiry) will have to necessarily submit sealed bid for any of the eligible items for which techno-commercially qualified, will be considered as tampering of the tender process and will invite action by BHEL as per extant guidelines in vogue.
3. BHEL will engage the services of a service provider who will provide all necessary training and assistance before commencement of on line bidding on internet.
4. In case of reverse auction, BHEL will inform the bidders the details of Service Provider to enable them to contact & get trained.
5. Business rules like event date, time, bid decrement, extension etc. also will be communicated through service provider for compliance.
6. Bidders have to fax the Compliance form (annexure IV) before start of Reverse auction. Without this, the bidder will not be eligible to participate in the event.
7. In line with the NIT terms, BHEL will provide the calculation sheet (e.g., EXCEL sheet) which will Packing & forwarding charges, Taxes and Duties, Freight charges, Insurance, Service Tax for Services and loading factors (for noncompliance to BHEL standard Commercial terms & conditions) for each of the bidder to enable them to fill-in the price and keep it ready for keying in during the Auction.
8. Reverse auction will be conducted on scheduled date & time.
9. At the end of Reverse Auction event, the lowest bidder value will be known on auction portal.
10. The lowest bidder has to fax/e-mail the duly signed and filled-in prescribed format for price breakup including that of line items, if required, (Annexure VII) as provided on case-to-case basis to Service provider within two working days of Auction without fail.
11. In case BHEL decides not to go for Reverse Auction procedure for this tender enquiry, the Price bids and price impacts, if any, already standard practice.
12. Bidders shall the auctions site of Service provider, using the Login IDs and passwords given to them by the service provider before reverse auction event. Bidders should acquaint themselves of the business rules of Reverse Auction, which will be communicated before the Reverse Auction.
13. If the Bidder or any of his representatives are found to be involved in Price manipulation/ cartel formation of any kind, directly or indirectly by communicating with other bidders, action as per extant BHEL guidelines, shall be initiated by BHEL and the results of the RA scrapped/ aborted.
14. The Bidder shall not divulge either his Bids or any other exclusive details of BHEL to any other party.
15. In case BHEL decides to go for reverse auction, the H1 bidder (whose quote is highest in online sealed bid) may not be allowed to participate in further RA process.

**SECTION – X****Bank Guarantee Format for Performance (PBG)**

(TO BE STAMPED IN ACCORDANCE WITH STAMP ACT AND THE EXPIRY DATE OF BG MUST BE AFTER 60 DAYS FROM THE DATE OF COMPLETION OF WARRANTY PERIOD)

In accordance of M/s. Bharat Heavy Electricals Limited (A Government of India undertaking, a company incorporated under the Companies Act 1956 having its Registered Office at “BHEL House”, SIRI Fort, New Delhi 110 049) through its High Pressure Boiler

Plant Division located at Tiruverumbur, Tiruchirapalli- 620 014 (hereinafter called ‘the Company’) having entered into a contract with .....hereinafter called ‘ the said contractor ‘ which term includes ‘suppliers’ for the purpose of this Bond and under the terms and conditions of the contract No..... Dt ..... Between BHEL, Trichy and as per the contract, the contractor / supplier is to furnish a performance Bank guarantee for Rs. .... for the due performance of the equipment to be supplied under the above referred contract and for the fulfillment of all the terms and conditions of the contract, We .....(indicate the name of the bank) (herein after referred to as the bank) at the request of ..... (Contractor(s) ) do here by undertake to pay the company an amount not exceeding Rs.....against any loss or damage caused to or suffered or would be caused to or suffered by the company by reason of any breach by the said contractor (s) of any of the terms and conditions contained in the said agreement.

2. We .....(indicate the name of the bank with full address), do hereby undertake to pay the amounts due and payable under this guarantee without any demur, merely on a demand from the Company stating that the amount claimed is due by way of loss or damage caused to or would be caused to or suffered by the Company by reason of breach by the said Contractor(s) of any of the terms and conditions contained in the said Agreement or by the reason of the contractor(s) ‘failure to perform’ the said agreement. Any such demand made on the Bank shall be conclusive as regards the amount due and payable by the Bank under this guarantee. However, our liability under this guarantee shall be restricted to an amount not exceeding Rs.\_\_\_\_\_.

3. We undertake to pay unconditionally to the Company any money so demanded notwithstanding any dispute(s) raised by the Contractor in any suit, or proceedings pending before any Court or Tribunal or Arbitration or before any other authority relating thereto our liability under this present being absolute and unequivocal. The payment under this guarantee would not wait till the disputes have been decided by any Court or Tribunal or in the arbitration proceedings or by any other authority. The payment so made by us under this Bond shall be a valid discharge of liability for payment thereunder and the Contractor(s) shall have no claim against us for making such payment.

4. We.....( indicate the name of Bank), further agree that the guarantee herein contained shall remain in full force and effect during the period that would

be taken for the performance of the said Agreement and that it shall continue to be enforceable till all the dues of the Company under or by virtue of the said Agreement have been fully paid and its claims satisfied or discharged or till \_\_\_\_\_ Office / Department/ Division of the Company certifies that the terms and conditions of the said Agreement have been fully and properly carried out by the said Contractor(s) and accordingly discharges this guarantee.

5. (I) Unless a demand or claim under this guarantee is made on us in writing on or before the \_\_\_\_\_ we shall be discharged from all the liability under this guarantee thereafter. But where such claim or demand has been preferred by the Company with the Bank before the expiry of the said date, the claim shall be enforceable notwithstanding the fact that the said enforcement is effected after the said date.

(ii) For the purpose of this clause, any letter making demand on the Bank by M/s. BHEL dispatched by Registered Post with Ack.Due or by Telegram or by any Electronic media addressed to the above mentioned address of the Bank shall be deemed to be the claim / demand in writing referred to above irrespective of the fact as to whether and when the said letter reaches the Bank, as also any letter containing the said demand or claim is lodged with the bank personally.

6. We .....(indicate the name of Bank), further agree with the company that the Company shall have the fullest liberty without our consent and without affecting in any manner our obligations hereunder to vary any of the terms and conditions of the said agreement or to extend time of performance by the said Contractor (s) from time to time or to postpone for any time or from time to time any of the powers exercisable by the Company against the said Contractor(s) and to forbear or enforce any of the terms and conditions relating to the said Agreement and we shall not be relieved from our liability by any reason of any such variation or extension being granted to the said Contractor(s) or for any forbearance, act or omission on the part of the company or any indulgence by the company to the said Contractor(s) or by any such matter or thing whatsoever which under the law relating would, but for this provision, have effect of not so relieving us.

7. This guarantee will not be discharged due to the change in the constitution of the Bank or the Contractor(s).

8. It shall not be necessary for the company to proceed against the contractor before proceeding against the guarantor-bank and the guarantee herein contained shall be enforceable against them notwithstanding any security, which the company may have obtained or obtain from the Contractor shall, at the time when proceedings are taken against the guarantor hereunder be outstanding or unrealised.

9. Any claim or dispute arising under the terms of this document shall only be enforced or settled in the Courts at Tiruchirapalli.

10. The guarantor hereby declare that it has power to execute this guarantee and the executant has full powers to do so on its behalf under the proper authorities granted to him/them by the guarantor.

11. We .....(indicate the name of Bank) lastly undertake not to revoke this guarantee during its currency except with the previous consent of the company in writing.

In witness whereof we....., (indicate the name of Bank) have hereunto setout Bank Seal the \_\_\_\_\_ day \_\_\_\_\_ month 200

BANK E-MAIL ID:  
BANK PHONE NO.  
BANK FAX NO:

**SECTION – XI**  
**LOADING CRITERIA**

<b>Payment Term (Indigenous)</b>	
<b>If materials are receivable at Project Sites without PBG</b>	<p><b><u>Option-1:</u></b> Payment term is 100% direct payment after 45 days from the date of dispatch against site acknowledgement</p> <p><b><u>Option-2: (REVISED)</u></b></p> <p>a) Payment term is 100% direct payment after 45 days from the date of dispatch against site acknowledgement.</p> <p style="text-align: center;"><b>(or)</b></p> <p>b) Payment term is 90% direct payment after 45 days from the date of dispatch against submission of dispatch documents and balance 10% against stores acknowledgement. <b>For this option –(b), a loading of 2% on the 90% of the offered value shall be made.</b></p>

<b>Payment Term (Imports) -</b>
BHEL Payment term is 100% payment on CAD basis after 45 days from the date of receipt of documents, specified in PO, at BHEL bank. Respective bank charges to respective account.
<b>Any deviation in the above payment term will attract loading as mentioned below. “Base rate of SBI (as applicable on the date of bid opening. Techno-commercial bid opening in case of two part bids) + 6% shall be considered for loading for the period of relaxation sought by bidders.</b>
<ul style="list-style-type: none"> <li>• <b>In the case of Usance LCs the loading will be considered @ 1.5% on the offered Value.</b></li> <li>• <b>For LC at sight the loading will be considered @ 3.5% on the offered Value.</b></li> <li>• <b>Normally CAD at sight and Confirmed LCs are liable for rejection.</b></li> </ul>

<b>Liquidated Damages / Penalty - To be incorporated in all NITs addressed to both Indigenous and Import Suppliers</b>
Liquidated damages shall be 0.5% of the total order value per week or part thereof subject to a maximum of 10% of the total order value.
<del>For staggered delivery schedule, LD shall be 0.5% of the undelivered portion per week of the delay or part thereof subject to a maximum of 10% of the total order value.</del>
Any deviation from the above LD clause, loading will be applied to the extent to which it is not agreed by the bidder (at offered value).

**SECTION – XII**  
**SPECIAL & COMMERCIAL TERMS**

<b>Special terms for Indian Suppliers</b>		
<b>Sl.no</b>	<b>Conditions</b>	<b>Vendor conformation</b>
1	Offer shall be submitted in <b>TWO PART</b> bid i.e Technical offer with commercial terms & conditions through BHEL e-procurement route only.	
2	Price may be finalized thro " <b>On line Reverse Auction Process</b> " using internet.	
3	Offer should be valid for a minimum period of 90 days, from the date of Price Bid Opening/Reverse Auction.	
4	Tender will be finalized on the basis of "Item wise total cost to BHEL basis".	
5	"Rate per number" to be quoted on "FOR Trichy Stores" basis with price breakup indicating basic price, P&F, ED,CST/VAT, freight charges separately. Insurance will be in BHEL scope.	
6	If the vendor is not conforming to our technical / drawing requirements in total, their offer will not be considered for further evaluation in this tender.	
7	Liquidated damages shall be 0.5% of the total order value per week or part thereof subject to a maximum of 10% of the total order value.	
8	Lowest Prices received against BHEL tender need not be the technically acceptable one and in that case BHEL reserve the right not to consider the same	
9	Guarantees shall be given for Eighteen months from the date of receipt of the material at Trichy Stores.	
10	BHEL reserves the right to increase or decrease the tendered quantity.	
11	Contact Details:- Name: _____ Designation: _____ Mobile: _____ Email: _____ Phone No: _____	

(Vendor Sign & Seal)

<b>Commercial Terms for Indian Suppliers</b>			
SL NO	CONDITIONS	BHEL TERMS	Accepted/Not Accepted
1	Delivery Terms	FOR Trichy Stores	
2	Delivery period	90 days from PO	
3	ED	Vendor to quote	
4	CST/VAT	Vendor to quote	
5	Freight	Vendor Scope	
6	Insurance	BHEL Scope	
7	LD	Delay in dispatches shall attract a penalty of Liquidated damages (LD) @ 0.5% of the total order value per week, subject to maximum of 10% on total PO value	
8	Risk Purchase	Applicable	
9	PBG	Not Applicable	
10	Payment terms	100% payment will be made in 45 days from the date of receipt of material at trichy stores.	
11	Validity	90 days from the date of RA/Price bid opening	
12	Firm Price	Firm Price	
13	PVC	Not Applicable	
14	Packing Forwarding	Vendor Scope	
15	Guarantee/Warranty	Guarantees shall be given for Eighteen months from the date of receipt of the material at Trichy Stores.	

(Vendor Sign &amp; Seal)

<b>Special terms for Foreign Suppliers</b>		
<b>Sl.no</b>	<b>Conditions</b>	<b>Vendor conformation</b>
1	Offer shall be submitted in <b>TWO PART</b> bid i.e Technical offer with commercial terms & conditions through e-procurement route only.	
2	Price may be finalized thro " <b>On line Reverse Auction Process</b> " using internet. Please confirm your acceptance.	
3	Offer should be valid for a minimum period of 90 days, from the date of Price Bid Opening/ Reverse Auction.	
4	Tender will be finalized on the basis of "item wise total cost to BHEL".	
5	"Rate per number" to be quoted on "CIF Chennai port" indicating price break up for FOB (mention port), Marine Insurance, Air/sea Freight etc separately.	
6	If the vendor is not conforming to our technical / drawing requirements in total, their offer will not be considered for further evaluation in this tender.	
7	Delay in dispatches shall attract a penalty of Liquidated damages (LD) @ 0.5% per week of total order value, subject to maximum of 10% of total order value.	
8	Lowest Prices received against BHEL tender need not be the technically acceptable one and in that case BHEL reserve the right not to consider the same	
9	Guarantees shall be given for Eighteen months from the date of receipt of the material at Trichy Stores.	
10	BHEL reserves the right to increase or decrease the tendered quantity.	
11	Contact Details:- Name: _____ Designation: _____ Mobile: _____ Email: _____ Phone No: _____	

(Vendor Sign &amp; Seal)

<b>Commercial Terms for Foreign vendors</b>			
<b>SL NO</b>	<b>CONDITIONS</b>	<b>BHEL TERMS</b>	<b>Accepted/Not Accepted</b>
1	Delivery Terms	CIF Chennai port	
2	Delivery period	By 24.04.2016	
3	Freight from Chennai to Trichy Stores	BHEL Scope	
4	Insurance	by BHEL (for Chennai to Site movement)	
5	LD	Delay in dispatches shall attract a penalty of Liquidated damages (LD) @ 0.5% per week of total order value, subject to maximum of 10% of total order value.	
6	Risk Purchase	Applicable	
7	PBG	Not Applicable	
8	Payment terms	BHEL Payment term is 100% payment on CAD basis after 45 days from the date of receipt of documents, specified in PO, at BHEL bank. Respective bank charges to respective account.	
9	Validity	90 days from date of RA/Price bid opening	
10	Firm Price	Firm Price	
11	PVC	Not Applicable	
12	Packing Forwarding	Vendor Scope	
13	Guarantee/Warranty	Guarantees shall be given for Eighteen months from the date of receipt of the material at Trichy Stores.	

(Vendor Sign &amp; Seal)

**SECTION – XIII****Supplier Registration Form**

Unregistered vendors may get registered with BHEL by filling SRF. Supplier Registration Form (SRF) has to be duly filled up online and send one copy with all the documents as mentioned in SRF.

URL for online Registration form is as below

<http://supplier.bhel.in/>

For any help regarding filling of SRF, you may contact following

<http://supplier.bhel.in/contact.jsp>

Name	Designation	Phone No.	Mail
Mrs. Nalini Subramanian	PURCHASE OFFICER	0431-2577301	nalini@bheltry.co.in
Mr. LJEYAPIRAGASH	SR MANAGER	0431-2577121	ljp@bheltry.co.in
Mr. M EBINESAN	DGM	0431-257448	ebi@bheltry.co.in
Mr. SIVASUBRAMANIAN P	SR MANAGER	0431-2577939	psivasub@bheltry.co.in
Mr. CHINNATHAMBI S	MANAGER	0431-2574215	scthambi@bheltry.co.in
Mr. SEKAR V.M	SR MANAGER	0431-2574608	vmsekar@bheltry.co.in

**Address**

DGM / SDC & ADMN /MM / MFG  
IV FLOOR, 24 BLDG  
UNIT:HPBP, BHEL  
TIRUCHIRAPALLI- 620014  
TAMIL NADU

For any queries regarding tender you may contact

Mr. Sachin Saini  
Engineer/MM/BOI  
BHEL Trichy  
0431-2577897

[sachinsaini@bheltry.co.in](mailto:sachinsaini@bheltry.co.in)

## SECTION – XIV

### MSE clause

**Clause: Special Provisions for Micro and Small Enterprises (MSE):**

1. 20% of the tendered quantity is earmarked for MSE suppliers in this tender.
2. Out of the 20% tendered quantity reserved for MSE suppliers, 4% shall be earmarked for procurement from MSE owned by SC / ST entrepreneurs.
3. In tender, participating MSE suppliers quoting price within price band of L1+15 per cent shall also be allowed to supply a portion of requirement by bringing down their price to L1 price in a situation where L1 price is from someone other than a MSE supplier and such MSE shall be allowed to supply up to 20% of total tendered value. In case of more than one such MSE, the supply shall be shared proportionately.
4. MSE suppliers can avail the intended benefits only if they submit along with offer, attested copies of either EM II certificate having deemed validity (Two years from the date of issue of acknowledgement in EM II) or valid NSIC certificate or EM II certificate along with CA certificate (Format enclosed) applicable for the year, certifying quantum of investment in plant and machinery within the permissible limit as per the act for relevant status (Micro or small) where the deemed validity of EM II is over. Date to be reckoned for determining the deemed validity will be the last date of technical bid submission. Non submission of such documents will lead to consideration of their bids at par with other bidders and MSE status of such suppliers shall be shifted to Non MSE supplier till the supplier submits these documents.

Non-submission of documents as per point no 4 above will disallow provisions under MSE clause mentioned above. These documents shall be submitted along with the technical/unpriced bid.

## SECTION – XV

### Guidelines for tender Submission

#### **BHEL e-Procurement website link**

<https://bheleps.buyjunction.in>

#### **For Part 1 (Techno-Commercial Part)**

Submit following signed documents along with Part 1 of your tender

1. Tender Form as per Section VII
2. Confirmation to Technical specifications & Drawings
3. Deviations taken (if any)
4. Unpriced price format duly sealed & signed as per section VIII
5. Commercial & Special terms duly sealed & signed as per section XII
6. Confirmation of submitting online supplier registration form (for non-registered vendors)
7. Any other relevant documents

#### **For Part 2 (Price Part)**

Submit following signed documents along with Part 2 of your tender

1. Filled up price format duly sealed & signed as per section VIII

#### **Requirements for uploading offer on BHEL's e-procurement system**

Suppliers interested for registration for BHEL Open Tenders should have a valid DSC before proceeding forward for Registration. Herein a Valid DSC refers to an Active and unexpired Signing and Encryption Certificate, with specification Class III SHA 2 2048 bit.

Refer following links for more details

1. [Procedure for Online Registration in EPS for Open Tender Suppliers](#)
2. [Supplier Manual](#)

For any assistance, please feel free to get in touch with EPS Toll Free Customer care: 180041920001 (9am To 5.30 pm, Monday to Saturday) or write to us at [eps.customercare@mjunction.in](mailto:eps.customercare@mjunction.in)

#### **E-Procurement Help Desk**

033-6601 1717 (From 9:30am to 5:30pm)

9163348283 - 86/8584008116 (From 5:30pm to 8:30pm)

## **e-Procurement Tender Submission for Unregistered Supplier**

### **MANDATORY REQUIREMENT:**

**Suppliers interested for registration for BHEL Open Tenders should have a valid DSC before proceeding forward for Registration. Herein a Valid DSC refers to an Active and unexpired Signing and Encryption Certificate, with specification Class III SHA 2 2048 bit Please follow the below steps for registration**

1. Visit <https://bheleps.buyjunction.in>. Click Register Button (Top of the Screen)
2. Please input your organization PAN No (in case of Indian supplier) or click "Foreign" in case you are an overseas Supplier.
3. Click on INTERESTED Button against the respective BHEL Unit
4. Key in you desired login id (Login Code should be 8 - 24 characters in length and can only use Numeric values) If you have registered by keying in PAN No. then your desired login id will be prefixed by "OTI", In case of overseas suppliers it will be prefixed with "OTF"
5. Fill in the other details.
6. Fill in the Captcha code and click next
7. Register your Signing certificate and click next
8. Select atleast one procurement category you may be dealing in.

Once the above steps are completed, your profile will be activated by mjunction within 2 business hours.

NB:-

BHEL Administrator or user will have no role for approving Registration and Open Tenders and DSC for Any supplier who has registered himself from the front END which is in case of OT.

### **Still any problem in registering or submitting offer**

Contact: Mjunction Customer care

033-6601 1717 (From 9:30am to 5:30pm)

9163348283 - 86/8584008116 (From 5:30pm to 8:30pm)

Please get in touch with them immediately. The contact details of the service provider is given below:

a. **DHANARAJ.P** email: [panneer.dhanaraj@mjunction.in](mailto:panneer.dhanaraj@mjunction.in), Cell 9500199108

b. **HELPDESK** email: [eps.customercare@mjunction.in](mailto:eps.customercare@mjunction.in), Phone No: 033- 66106426 /6217/6013/6046/6176, 9163348283 / 9163348284 / 9163348285 / 9163348286 / 8584008116

c. **PETER RAJ** – Cell +91 9942069052, email - [peter.raj@mjunction.in](mailto:peter.raj@mjunction.in)

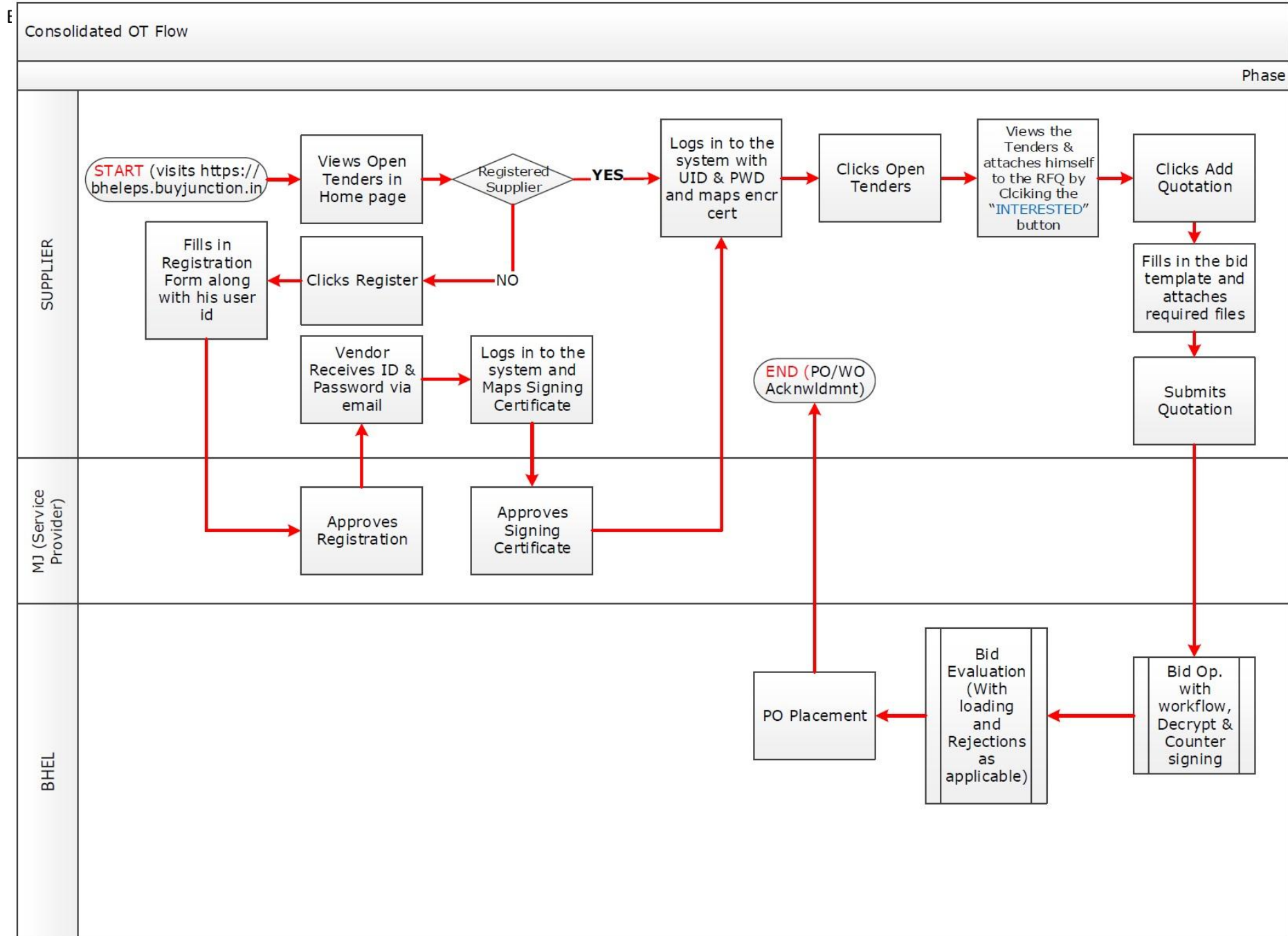



**TECHNICAL SPECIFICATION FOR GRAPHITE ALLOY BUSHINGS/BEARINGS  
TFS:1001A/REV.02**

**1.0 Scope:**

Design, manufacture and supply of Graphite alloy bushings/bearings used in low speed rotating shafts of tilt mechanism and damper assembly of windboxes / burners. Bushings shall be supplied in machined condition to meet the dimensional requirements as per the Variant or Style # indicated in the enquiry.

**2.0 Items**

Item No.	Item Description	Material Code	Reference Drawing
Item 1	Graphite Alloy Damper Bearing	970380010000	4-45-320-01618A
Item 2	Graphite Alloy Bushing	970380020000	3-45-000-01273A/Var 03
Item 3	Graphite Alloy Bushing	970380030000	3-45-000-01283A/Var 08
Item 4	Graphite Alloy Bushing	970380040000	3-45-000-01283A/Var 09

**3.0 Purpose**

Graphite alloy bushings are used in shafts, where maintenance of bushings/bearings is remote.

**4.0 Technical parameters**

Material	Graphite alloyed with metal
Mechanical Properties	Tensile Strength: Approx. 6000 psi Compressive Strength: Approx. 21000 psi Hardness: Scleroscope scale 40-50 Apparent density: Approx. 2.3 g/cc Coefficient of thermal expansion: Approx. $5.6 \times 10^{-6}$ mm/mm °C
Working temperature	400 °C
Features	Self-lubricating, dimensionally stable at all working temperature conditions, low coefficient of friction, shall work without any lubrication
Dimensions	Shall be as per the specified variant of BHEL drawing against the material code specified in the above table.

Prepared	Checked	Approved
Dheeraj Kumar	Venkateswarlu M	G Saravanakumar



**5.0 Packing**

Vendor shall use liberal packing material for shipment with proper handling instructions.

**6.0 Documents required**

Vendor shall submit point-wise confirmation to the specification.

**7.0 Inward Inspection**

Visual inspection

Dimensional check

Check for any damages

Prepared	Checked	Approved
Dheeraj Kumar	Venkateswarlu M	G Saravanakumar

CAUTION: THE INFO ON THIS DOCUMENT IS THE PROPERTY OF BHEL. IT MUST NOT BE USED DIRECTLY OR INDIRECTLY IN ANY WAY DETRIMENTAL TO THE INTEREST OF BHEL.

REV	DATE	ALTERED :DHEERAJ KUMAR
01	12.11.2014	CHD & APPD:G SARAVANAKUMAR
RADIUS OF BEARING ADDED		

FOR TOLERANCES OF UNTOLERANCED DIMENSIONS DURING MANUFACTURE REFER PLANT STD. NO TP 023 0299

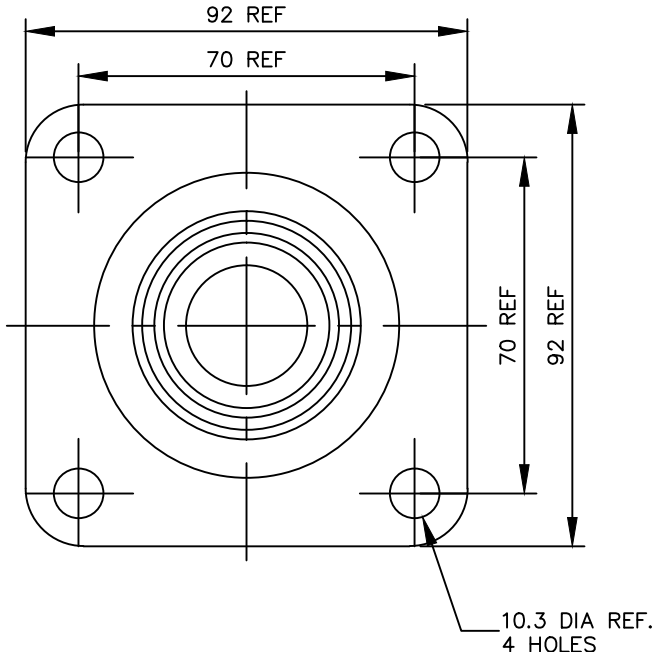
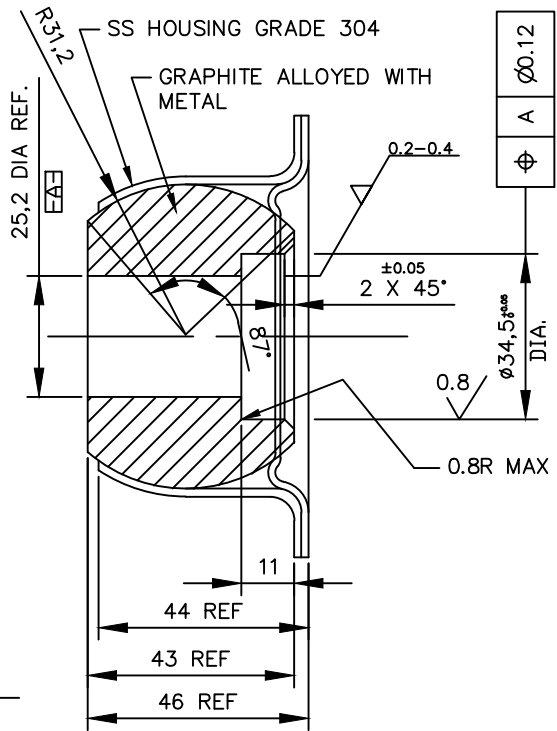

- NOTE:
1. ALL DIMENSIONS ARE MILLIMETERS
  2. UNSPECIFIED TOLS : DIMS ±0.8
  3. REFER ASSLY DRAWING NO 2-45-000-01392A
  4. TECHNICAL SPECIFICATION REFER TFS:1001A

	DAMPER BEARING		SUBDELIVERY		0.500
VARIANT NUMBER	DESCRIPTION	STD	MATERIAL CODE	A/C/P	UNIT WEIGHT
			MATERIAL SPECN	UNIT	QUANTITY



Bharat Heavy Electricals Ltd  
 UNIT: HIGH PRESSURE BOILER PLANT  
 TIRUCHIRAPALLI - 620014

DRN	NAME	SIGNATURE	DATE
CHD	BIMAL.C	-sd-	15-03-2011
APPD	GSK	-sd-	15-03-2011
	MTP	-sd-	15-03-2011

DEPT	ALL DIMENSIONS ARE IN MM	PROJECTION	SCALE	WEIGHT (Kg)	REF TO ASSY / OLD DWG
FS			N.T.S		
CODE	129				

TITLE	DRAWING NO :	REV
SELF ALIGNING FLANGE DAMPER BEARING	4-45-320-01618A	01

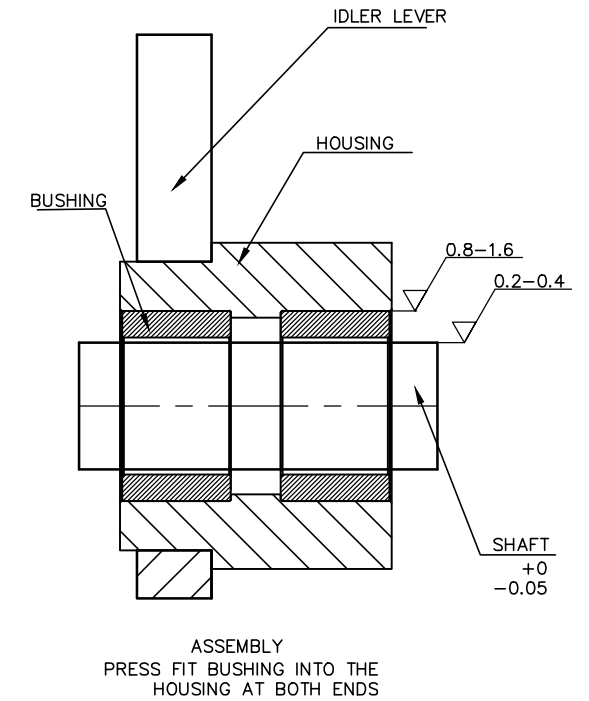
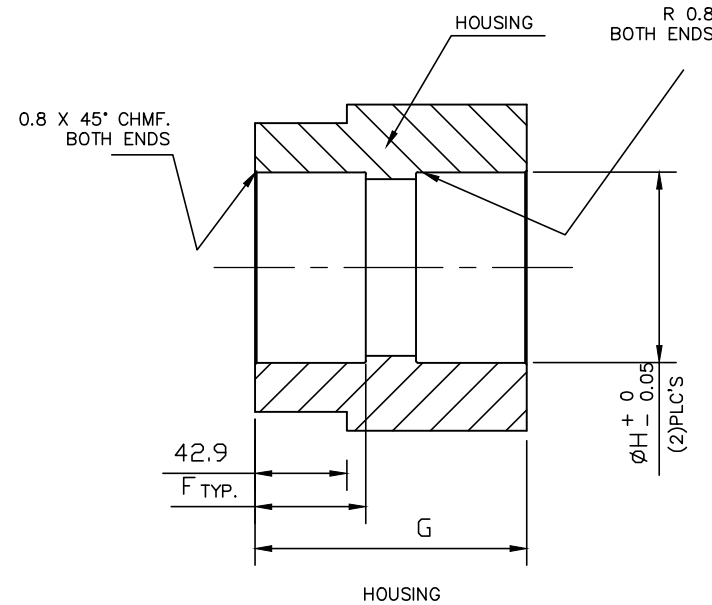
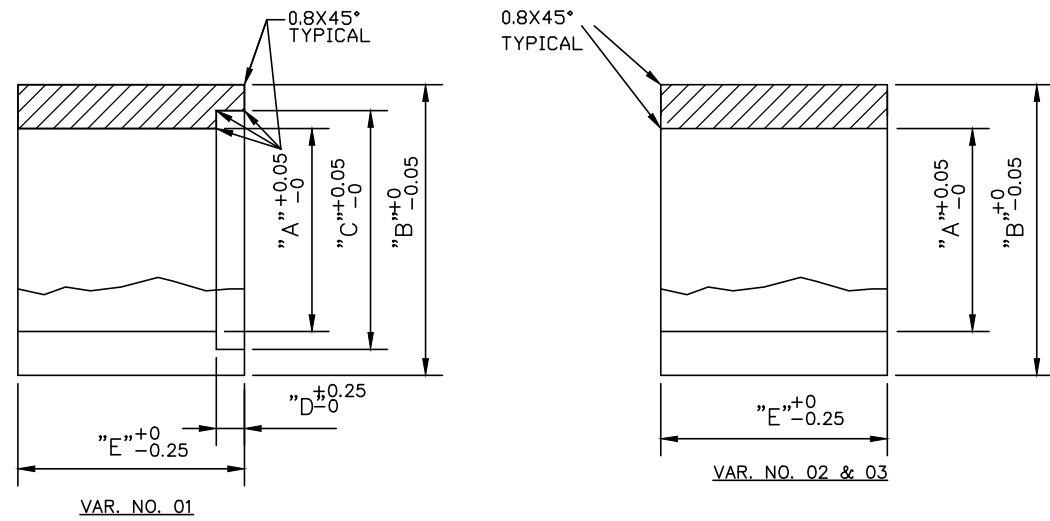

VAR. NO.	DESCRIPTION	STD	DRAWING NUMBER	ITEM NO	MATERIAL CODE	A/C/P	UNIT	UNIT WEIGHT
ITEM NUMBER				VAR NO	MATERIAL SPECN		DI	QUANTITY
03	GRAPHITE ALLOY BUSHING; OD89.3 / ID64							0.003
02	GRAPHITE ALLOY BUSHING; OD57.4 / ID38.5							0.002
01	GRAPHITE ALLOY BUSHING; W/SEAL; OD57.4/ID38.5							0.002

VAR. NO.	"A"	"B"	"C"	"D"	"E"	"F"	"G"	"H"
01	38.5	57.4	47.5	7	59	61	145	57
02	38.5	57.4	----	----	50	52	127	57
03	64	89.3	----	----	50	52	127	88.9

**NOTES:**

- ALL DIMENSIONS ARE IN mm.
- UNSPECIFIED TOLERANCES: DIMS  $\pm 0.8$ ; ANGLES  $\pm 0^\circ - 15'$

REV 01	DATE 06.11.14	ALTERED : DHEERAJ
		CHD & APPD: GSK
ZONE	HOUSING AND ASSEMBLY VIEWS ADDED DIMENSIONS "F", "G" AND "H" ADDED	

CAUTION: The information on this document is the property of BHARAT HEAVY ELECTRICALS LTD. It must not be used directly or indirectly in any way detrimental to the interest of the company.

TYPE OF PRODUCT OR NAME OF CUSTOMER/PROJECT				DRN		NAME		SIGNATURE		DATE			
Bharat Heavy Electricals Ltd UNIT: HIGH PRESSURE BOILER PLANT TIRUCHIRAPALLI - 620014 355-055				CHD		G S K		-sd-		31.12.2010			
				APPD		M T P		-sd-		31.12.2010			
				DEPT FS		ALL DIMENSIONS ARE IN MM		PROJECTION		SCALE		WEIGHT (Kg)	
CODE 129						N T S							
TITLE								DRAWING NO :				REV	
<b>IDLER BUSHING</b>								<b>3-45-000-01273A</b>				<b>01</b>	

3-45-000-01283A

DRAWING NO.

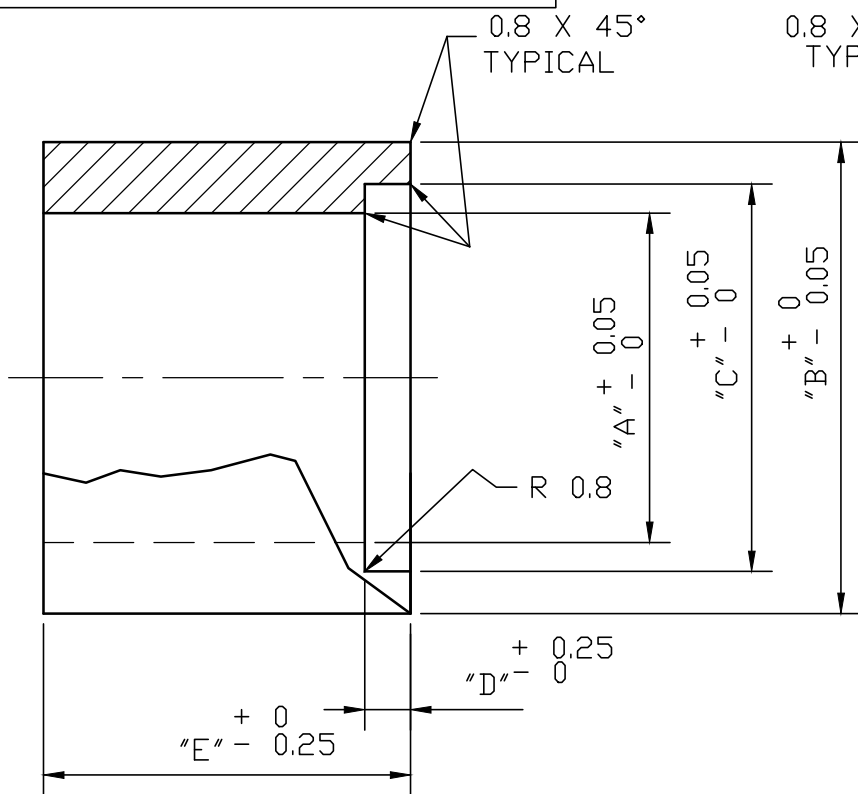

STYLE NO. B

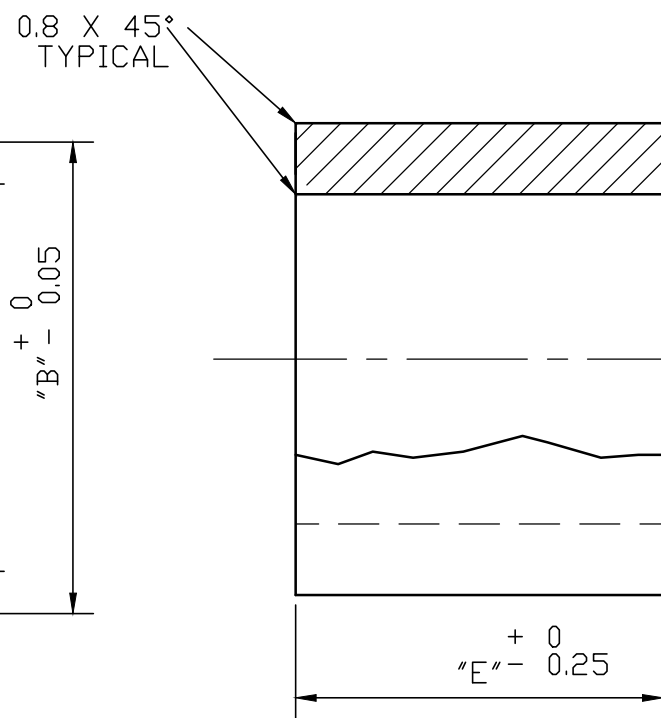

STYLE NO. A

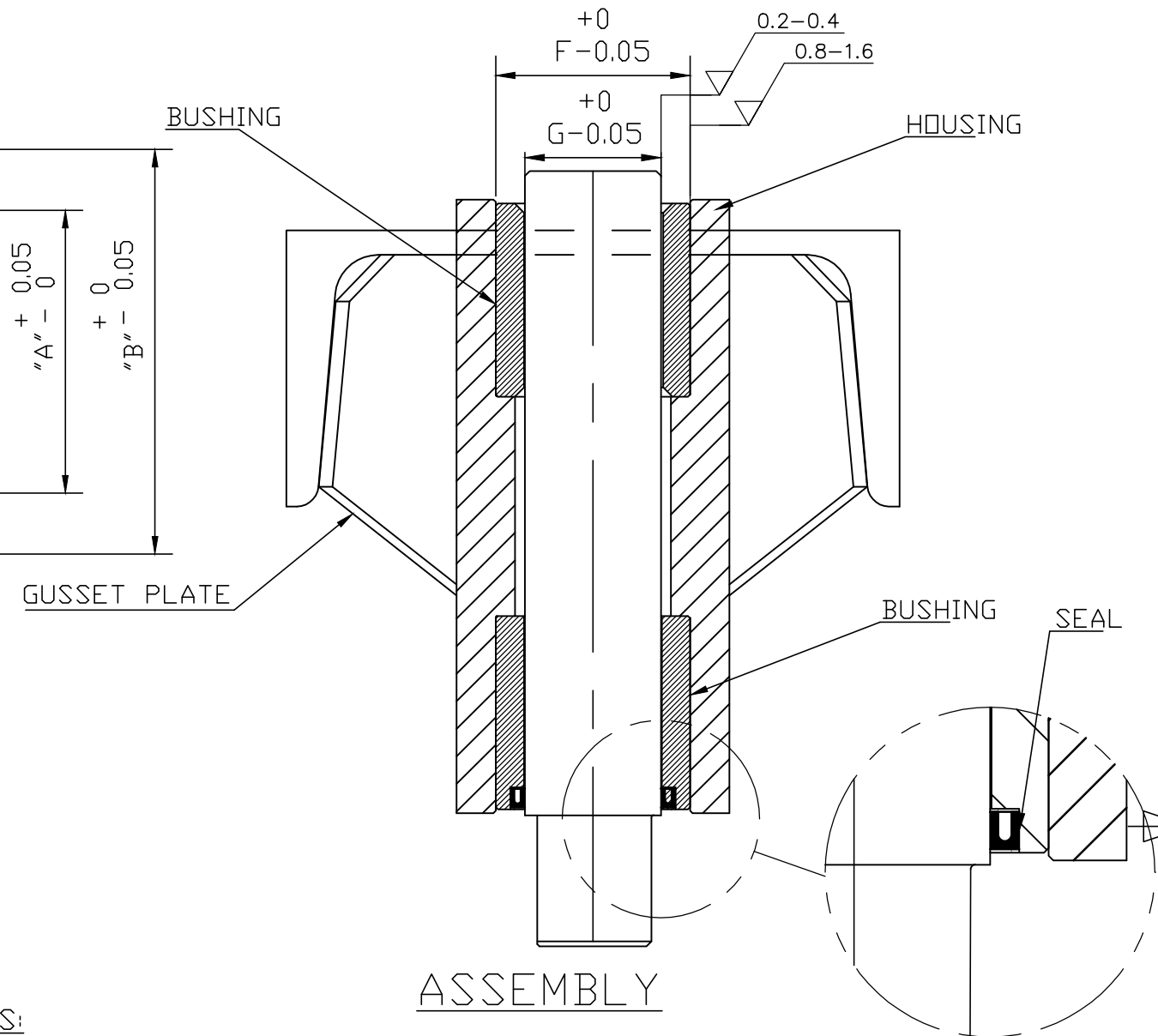

ASSEMBLY

VARIANT NO.	STY. NO.	DIM. "A"	DIM. "B"	DIM. "C"	DIM. "D"	DIM. "E"	DIM. "F"	DIM. "G"
01	A	36.7	52.7	----	----	50.3	52.4	35.76
02	A	51.3	73.4	----	----	50.8	70	50.76
03	B	51.3	73.4	60.2	7.1	57.1	70	50.76
04	A	25.3	35.1	----	----	44.5	34.8	24.36
05	A	38.6	60.7	----	----	50.3	60.4	37.66
06	B	38.6	60.7	47.5	7.1	50.3	60.4	37.66
07	A	38.6	60.7	----	----	69.3	60.4	37.66
08	A	45	63.8	----	----	63.5	63.5	44.42
09	B	45	63.8	53.9	7.1	63.5	63.5	44.42

NOTES:

1. ALL DIMENSIONS ARE IN mm.
2. UNSPECIFIED TOLERANCES: DIMS ±0.8; ANGLES ±0°-15'

MATERIAL SPECIFICATION  
GRAPHITE IMPREGNATED WITH METAL ALLOY

REV 01	DATE 06.11.14	ALTERED : DHEERAJ CHD & APPD: GSK
ZONE	ASSEMBLY VIEW ADDED DIMENSIONS "F", AND "G" ADDED	

TYPE OF PRODUCT OR NAME OF CUSTOMER/PROJECT			
 Bharat Heavy Electricals Ltd UNIT: HIGH PRESSURE BOILER PLANT TIRUCHIRAPALLI - 620014			
DEPT FS	ALL DIMENSIONS ARE IN MM	PROJECTION	SCALE NTS
CODE 129	WEIGHT (Kg) ---	REF TO ASSY / OLD DWG	
TITLE			REF TO ASSY / OLD DWG
<b>BUSHING</b> (GRAPHITE ALLOY)			DRAWING NO : <b>3-45-000-01283A</b>
			DATE 13/01/2011 SIGNATURE -sd- NAME G S K DRN DATE 13/01/2011 SIGNATURE -sd- NAME G S K CHD DATE 13/01/2011 SIGNATURE -sd- NAME M T P APPD
			REV <b>01</b>

CAUTION: The information on this document is the property of BHARAT HEAVY ELECTRICALS LTD. It must not be used directly or indirectly in any way detrimental to the interest of the company.

**NOTES:**

1. ALL DIMENSIONING AND TOLERANCING AS PER ASME Y14.5M-1994 UNLESS OTHERWISE SPECIFIED.
  - a. ALL DIMENSIONS ARE IN mm.
  - b. TOLERANCES ON DIMENSIONS  $\pm 0.1$
  - c. TOLERANCE ON ANGULAR DIMENSIONS  $\pm 0^\circ 30'$
3. WELD PER D1.1 USE E-7018 ELECTRODE.

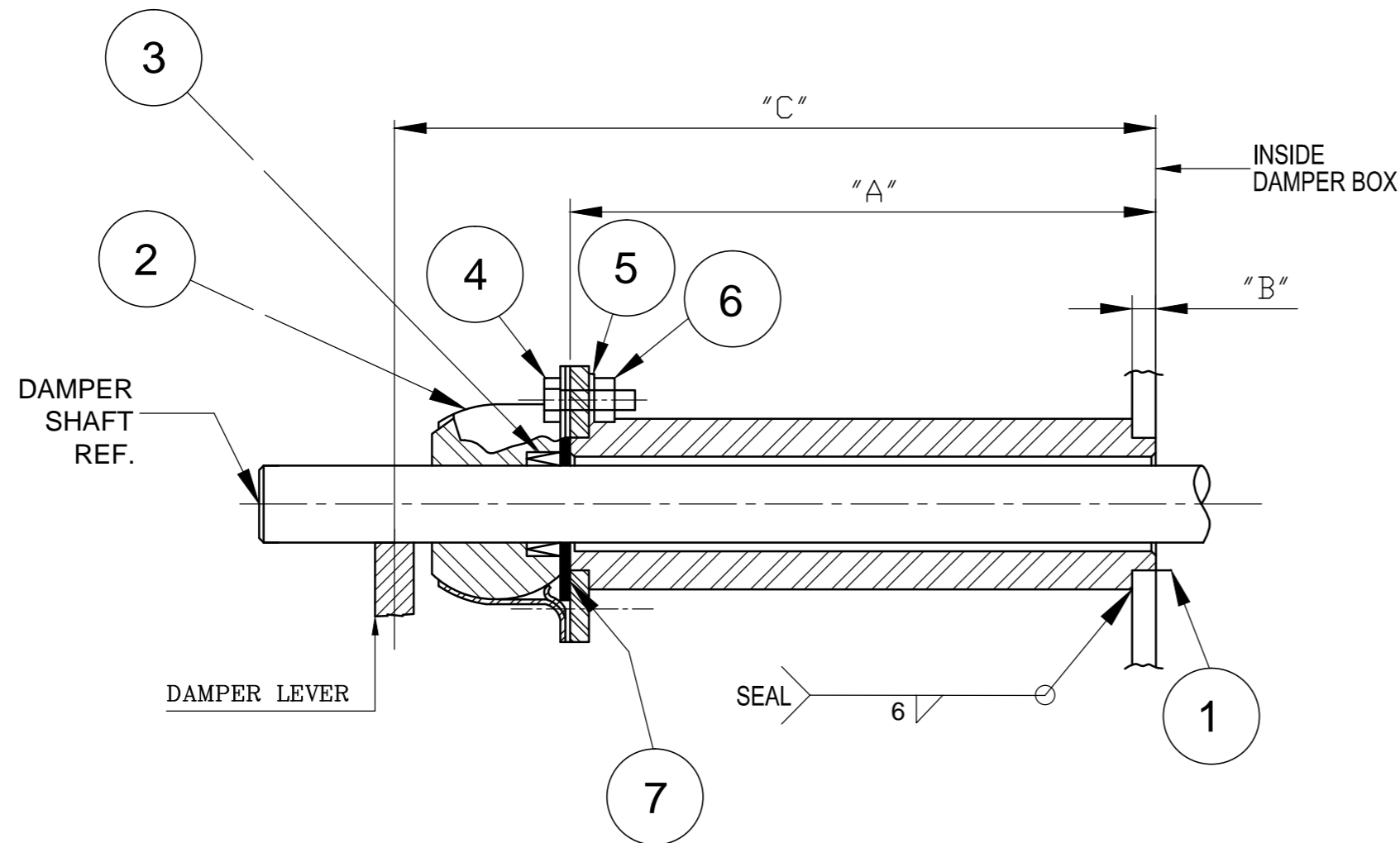

VAR.NO.	DIM "A"	DIM "B"	DIM "C"	INSUL THK	TOT. WEIGHT
01	202 197	18 10	255	127	5.637
02	154	10	203	100	5.530
03	275 272	13 10	330	200	6.557

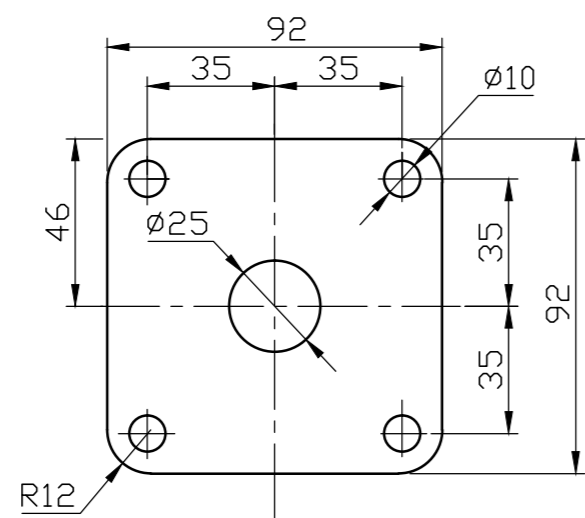

GASKET FOR THE ASSLY.  
ITEM NO : 9

VARIANT NUMBER	ITEM NUMBER	DESCRIPTION	STD	DRAWING NUMBER	ITEM NO	MATERIAL CODE	A/C/P	UNIT	UNIT WEIGHT	CS	ZONE
					VAR NO	MATERIAL SPECN	DI	QUANTITY			
COMMON FOR ALL VARIANTS											
	07	GASKET				220205250000 AA 21502			0.053		
	06	HEX NUT M8				413040000800 IS: 1363			0.005		
	05	SPRING LOCK WASHER M8				414050000800 IS: 3063			0.002		
	04	HEX HD BOLT M8 X 25LG				412220802500 IS: 1363			0.014		
	03	SPRING SEAL				REF GMS SUB-DELY.			0.005		
	02	BEARING ASSY	4-45-320-01618A			REF GMS SUB-DELY.			0.500		
03	01	DAMPER BRG HOUSING ASSY	3-45-320-01208		03				2.73		
02	01	DAMPER BRG HOUSING ASSY	3-45-320-01208		02				1.703		
01	01	DAMPER BRG HOUSING ASSY	3-45-320-01208		01				2.11		

CAUTION: The information on this document is the property of BHARAT HEAVY ELECTRICALS LTD. It must not be used directly or indirectly in any way detrimental to the interest of the company.	TYPE OF PRODUCT OR NAME OF CUSTOMER/PROJECT							
	 Bharat Heavy Electricals Ltd UNIT: HIGH PRESSURE BOILER PLANT TIRUCHIRAPALLI - 620014		DRN	B.Chowdhury	SIGNATURE	-sd-	DATE	10.03.11
			CHD	J.V.V.Arana Kumar	SIGNATURE	-sd-	DATE	10.03.11
			APPD	M.Thandapani	SIGNATURE	-sd-	DATE	10.03.11
	DEPT	FS	ALL DIMENSIONS ARE IN MM	PROJECTION	SCALE	WEIGHT (Kg)	REF TO ASSY / OLD DWG	
CODE	129		NTS	7.185				
TITLE						DRAWING NO :		REV
BEARING ASSEMBLY						2-45-000-01392A		00

