



An ISO 9001
Company

Bharat Heavy Electricals Limited

(High Pressure Boiler Plant)

Tiruchirappalli – 620014, TAMIL NADU, INDIA

MATERIALS MANAGEMENT

TITLE N2 Blanketing System	Phone: +91 431 257 7994 Fax : +91 431 252 0719 Email : joydevsardar@bheltry.co.in
---	---

	Reference Number: Enquiry 1801501287	Enquiry Date: 25.11.2015	Due date for submission of quotation: 18.12.2015
--	---	---	--

You are requested to quote the Enquiry number date and due date in all your correspondences. This is only a request for quotation and not an order

BHEL/Trichy is looking for empanelment of new vendors for supply of "N2 Blanketing System as per attached specification No.PCPS:24:732/00 and Drawing No:2-24-465-80991/01"

BHEL commercial terms & conditions with Price Bid formats and all annexure can be downloaded from BHEL web site <http://www.bhel.com> or from the Government tender website <http://tenders.gov.in> (public sector units) Bharath Heavy Electricals Limited) under enquiry reference "1801501287"

Tenders should reach us before 14:00 hours on the due date
Technical bid will be opened at 14:30 hours on the due date
Tenders would be opened in presence of the tenderers who have submitted their offers and who may like to be present.

Yours faithfully,
For **Bharath Heavy Electricals Limited**

DGM / MM



(A Government of India Undertaking)
 HIGH PRESSURE BOILER PLANT
 PURCHASE DEPARTMENT - FOSSIL BOILERS
 THIRUCHIRAPALLI - 620014
 TAMILNADU (INDIA)

PHONE : 2577359
 GRAMS : BHARATELEC
 FAX NO: 2520719
 E-mail :
 Web :

429-002/A

OFFICE COPY	Collective No.	Enquiry Date	Due Date For Quotation
	1801501287	25.11.2015	18.12.2015
Please quote Enquiry No, Date and due date in all correspondences. This is only a request for quotation and not an order			

Item	Description	Unit	Quantity	Delivery Quantity	Schedule Date
10	591540010000	NO	3.000	3.00	10.05.16
NITROGEN BLANKETING SYSTEM AS PER SPECN.PCPS:24:732/00					

General Note:

- 1) This is an open tender and same has been published on BHEL & NIC website http://www.bhel.com/tender/tender_home.php & <http://tenders.gov.in> and also in leading dailies. All corrigendums will be published on BHEL & NIC websites only. Vendors are requested to visit these websites regularly.
- 2) Kindly submit your offer in two parts as per attached Drawing and also carefully read all the annexures before submitting the offer.

Enclosures:

- 1)Annexure-I
Specification No.PCPS:24:732/00 & Drawing No.2-24-465-80991
- 2) Annexure-II - Loading terms
- 3) Annexure-III - General Terms
- 4) Annexure-IV - Terms & conditions
- 5) Annexure-V - MSE clause
- 6) Annexure-VI - SRF

"LD clause has to be confirmed without fail."

The bidder along with its associate / collaborators / sub-contractors / sub-vendors / consultants /service providers shall strictly adhere to BHEL fraud prevention policy displayed on BHEL website <http://www.bhel.com> and shall immediately bring to the notice of BHEL Management about any fraud or suspected fraud as soon as it comes to their notice.

PR Links

Material.	PR.No	PR.Item.	Quantity	Acc. Assign	Customer Number
591540010000	113947090	00010	1.000	H1/5767-HT-197-1-24-465	H1/5767

The offers should reach us 30 minutes before the time of opening of tenders. The offers will be opened at 14.30 hrs on the due date of tender in the presence of tenderers who have submitted their offer and who may like to be present for the tender opening.Late and delayed offers are liable to be rejected.

Yours faithfully,
 For **BHARAT HEAVY ELECTRICALS LIMITED**

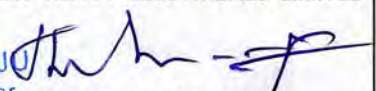
S. SELVARAJU
 Senior Manager
 Materials Management / PO
 (FOSSIL BOILERS)
 BHEL, TIRUCHY - 620 014



BHARAT HEAVY ELECTRICALS LIMITED

(A Government of India Undertaking)
HIGH PRESSURE BOILER PLANT
PURCHASE DEPARTMENT - FOSSIL BOILERS
THIRUCHIRAPALLI - 620014
TAMILNADU (INDIA)

Page:2/2

1801501287 / 25.11.2015

23505

Material.	PR.No	PR.Item.	Quantity	Acc. Assign	Customer Number
591540010000	113947090	00020	1.000	H1/5768-HT-397-1-24-465	H1/5768
591540010000	113947090	00030	1.000	H1/5765-HT-170-1-24-465	H1/5765

list of suppliers

RFQ-5200004498

Open Tender Dummy Code

The offers should reach us 30 minutes before the time of opening of tenders.
The offers will be opened at 14.30 hrs on the due date of tender in the presence of tenderers who have submitted their offer and who may like to be present for the tender opening.Late and delayed offers are liable to be rejected.

Yours faithfully,
For BHARAT HEAVY ELECTRICALS LIMITED

S. SELVARAJU
Senior Manager / PURCHASE
Materials Management / FOSSIL BOILERS
BHEL, TIRUCHY - 620 014
Yours faithfully,



Specification No.: PCPS:24:732/00

Standard Technical Specification for Supply of Nitrogen Blanketing System

Contents

Sl. No.	Description	Page No
	Index Sheet	01 of 03
I	Engineering Specification	
1.1	General information	02 of 03
1.2	Scope of work by vendor	02 of 03
1.3	Bill of Materials to be supplied	02 of 03
1.4	Testing Requirements	02 of 03
1.5	Documents to be supplied	02 of 03
2.0	Check list for Nitrogen Blanketing system	03 of 03
II	Annexure	
1	Nitrogen blanketing system- Drawing no. 2-24-465-80991.	

	Prepared	Reviewed	Approved	Date	Revision
Name	Madhava Nand Dwivedi	S.Kiraha Prakash	N.Kathirvel	18.12.13	00
Sign					



I - Engineering Specification

1.1 General information:

- a. This Specification covers the Design, Manufacture and supply of Nitrogen Blanketing System for HRSG. This is essential for preservation of the internals of boiler during long shutdown.
- b. The function of the system is to connect 4 nitrogen cylinders to a common manifold and supply the nitrogen requirement of the boiler, during shut down.
- c. The arrangement of the skid nitrogen cylinder to the common manifold connection, common manifold arrangement and termination at non return valve as per the drawing 2-24-465-80991.
- d. The supply of the skid shall be as per the drawing referred and the bill of material given in the drawing.

1.2 Scope of work by vendor

- a. The vendor's scope of supply starts from the outlet of the Nitrogen cylinder to the non-return valve of common manifold, as referred in the drawing 2-24-465-80991, in assembled condition.
 - i. Manifold system : As per drawing No. 2-24-465-80991.
 - ii. Isolating valves : Hand operated valves as per ANSI / Equivalent standard.
 - iii. No of systems : One system per Boiler.

1.3 Bill of materials to be supplied

Refer the Bill of Materials provided in the drawing with materials and sizes as given in drawing 2-24-465-80991.

1.4 Testing requirements

Complete system shall be Hydro tested to a pressure of 237 Kg/Sq.cm. (g)

1.5 Documents to be submitted

- a. Along with offer
 - i. 3 sets of Technical data sheet.
 - ii. Assembly Drawing with Bill of Material covered.
 - iii. Catalogues of valves and other sub-assemblies.
- b. After placements of order
 - i. 3 sets of detail drawing with bill of material for BHEL's approval.
 - ii. 3 sets of Test certificates
 - iii. O&M manual -1 set of soft copy in pdf, with 3 sets of hard copies.

Prepared	Checked	Approved	Date	Specification No	Rev No	Page
Madhava Nand Dwivedi	S.Kiraha Prakash	N.Kathirvel	18.12.13	PCPS:24:732	00	02 of 03
<i>med</i>	<i>S.Kiraha</i>	<i>N.Kathirvel</i>				



3.0 Check list for Nitrogen Blanketing system

S.No	Description	Vendor Confirmation (Mark ✓ to confirm)	
		Yes	No
I	Along with the offer:		
a.	Technical data sheet		
b.	Assembly drawing with Bill of material		
c.	Catalogues of valves and other sub-assemblies		
II	After placement of order:		
a.	3 sets of detail drawing with bill of material for BHEL's approval		
b.	3 sets of Test certificates.		
c.	O&M manual -1 set of soft copy in pdf, with 3 sets of hard copies		
III	GENERAL:		
<i>Without the above Details/confirmation the Offer will be treated as Incomplete and Liable for Rejection.</i>			

We confirm that all the details are furnished as per above check list.

Date:

(Authorized signature of the vendor)

With office seal

Prepared	Checked	Approved	Date	Specification No	Rev No	Page
Madhava Nand Dwivedi <i>madhava nand</i>	S.Kiraha Prakash <i>S. Kiraha</i>	N.Kathirvel <i>N. Kathirvel</i>	18.12.13	PCPS:24:732	00	03 of 03

DESIGN PARAMETER:

- 01. DESIGN PRESSURE: 158KG/CM² (g)
- 02. DESIGN TEMPERATURE: 350°C
- 03. HYD. TEST PRESSURE: 237 KG/CM² (g)

NOTES:

- 01. ONE SET OF KEY SHALL BE PROVIDED FOR THE EACH KEY OPERATED VALVES.
- 02. THE EQUIPMENTS SHOWN IN DOTTED LINE ARE NOT IN THE SCOPE OF VENDOR
- 03. THE PRESSURE GAUGE ARRANGEMENT SHALL BE AS SHOWN IN THE ISOMETRIC ARRANGEMENT
- 04. 3-WAY VALVE SHALL HAVE M20X1.5 THREAD CONNECTION TO FIT THE PRESSURE GAUGE
- 05. THE LENGTH OF ISMC-100 (ITEM NO.15) IS TO BE SUITABLY DECIDED BY THE VENDOR
- 06. OPEN END OF PIGTAIL (ITEM NO.02) WHICH WILL BE CONNECTED TO N₂ CYLINDER SHOULD HAVE MATCHING END CONNECTION AS PER PREVAILING STANDARDS.
- 07. THIS DRAWING IS TO BE READ ALONG WITH SPEC. No. PCPS:24:732/00.

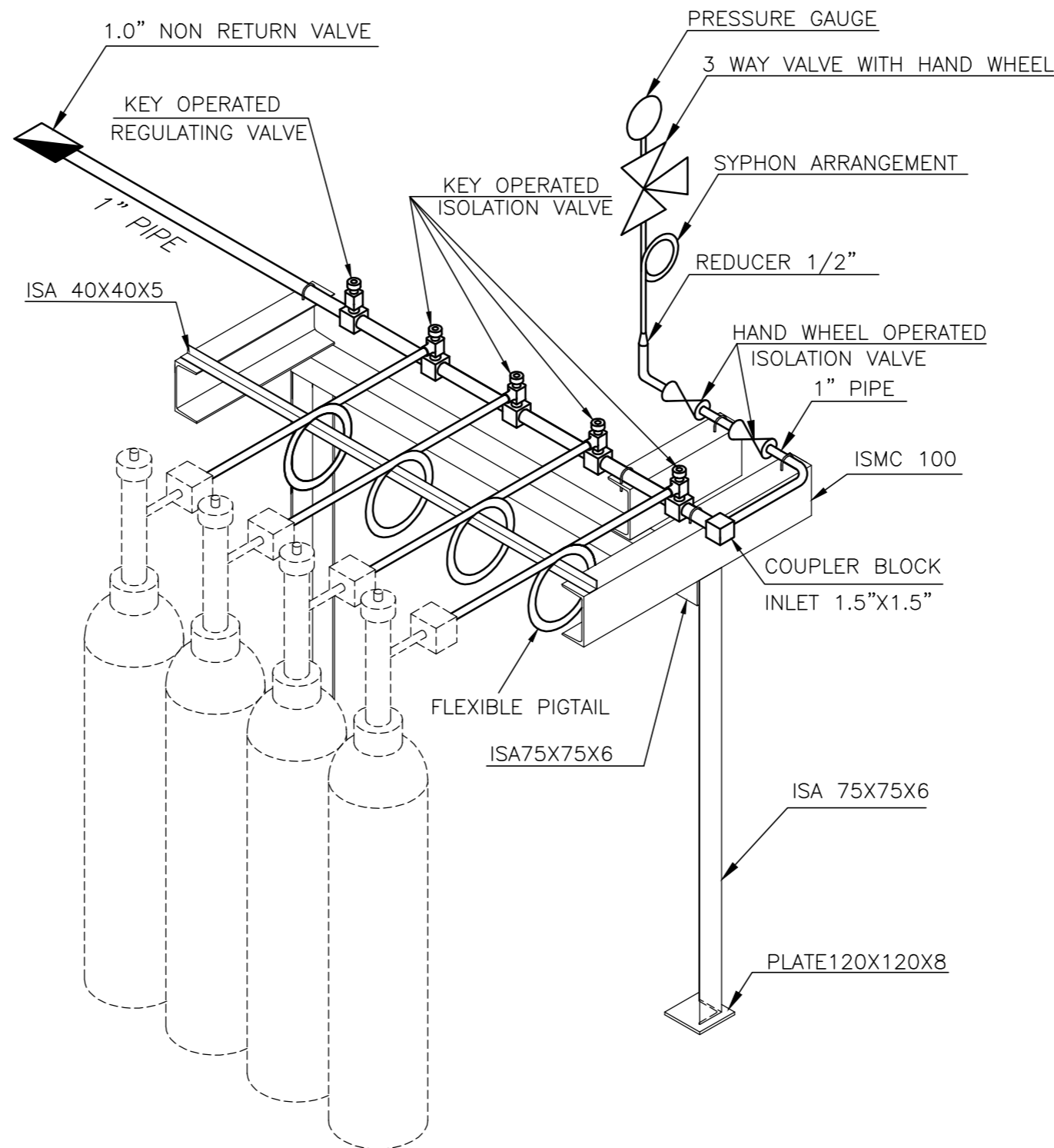
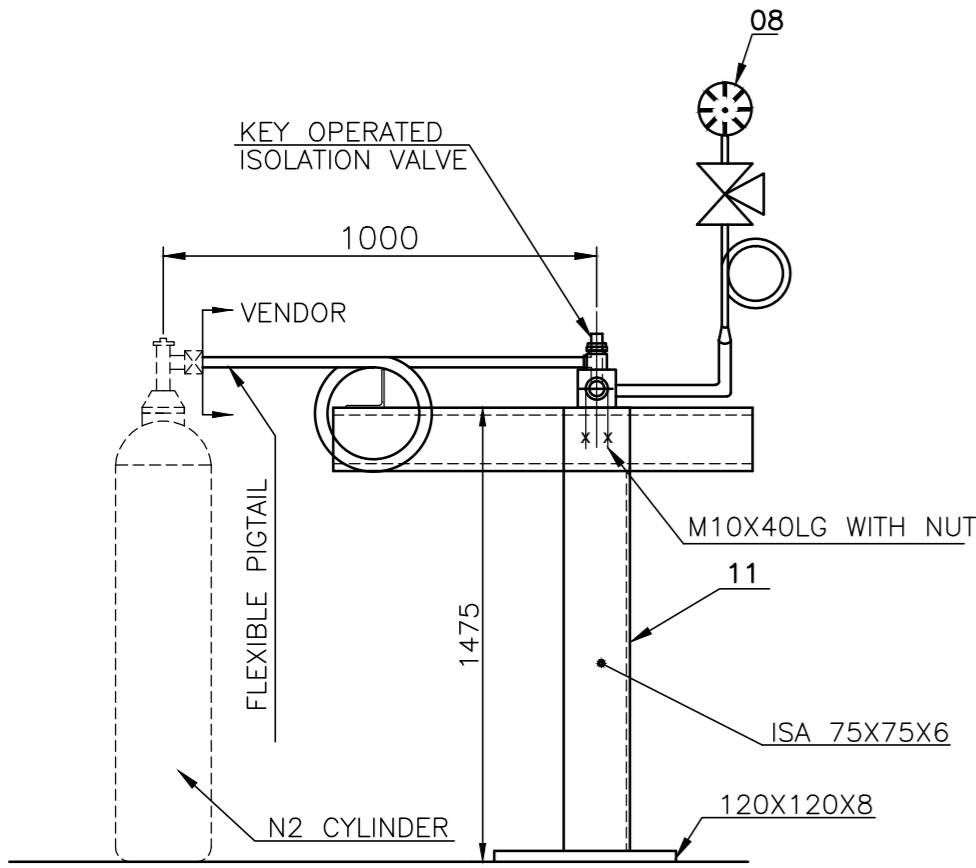

SL NO	DESCRIPTION	MATERIAL SPECIFICATION	QTY
18	HAND OPERATED VALVE	ASTM-B75 TYPE DBH BS2871C106	2 NO
17	ISA 40X40X5	IS 2062	1 NO
16	1" U-BOLT WITH NUT	-	7 NO
15	MANIFOLD SUPPORT CHANNEL ISMC-100	IS 2062	2 NO
14	3 WAY VALVE (SS)	STAINLESS STEEL	1 NO
13	SIPHON	STAINLESS STEEL	1 NO
12	REDUCER 1.5"	SA 182 F304	1 NO
11	MANIFOLD SUPPORT ISA 75X75X6	IS 2062	2 NO
10	MANIFOLD MOUNTING PLATE PL. 120X120X8	IS 2062	2 NO
09	1.0" NON RETURN VALVE SOCKET WELDED	SA 182 F304	1 NO
08	PRESSURE GAUGE DIAL 150MM RANGE 0-250 KG/CM ²	DIE CASTED ALUMINIUM WEATHER PROOF	1 NO
07	REGULATING VALVE IS3224	IS 319/BS249	1 NO
06	COUPLER BLOCK OUTLET 1.0"x1.0"	IS 319/BS249	1 NO
05	COUPLER JOINT 1.5"x1.5"	IS 319/BS249	4 NO
04	COUPLER-1" PIPE	ASTM-B75 TYPE DBH BS2871C106	1 NO
03	KEY OPERATED ISOLATING VALVE IS3224-1"	ASTM-B75 TYPE DBH BS2871C106	4 NO
02	FLEXIBLE PIGTAIL	ASTM-B75 TYPE DBH	4 NO
01	COUPLER BLOCK INLET 1.5"x1.5"	IS 319/BS249	1 NO

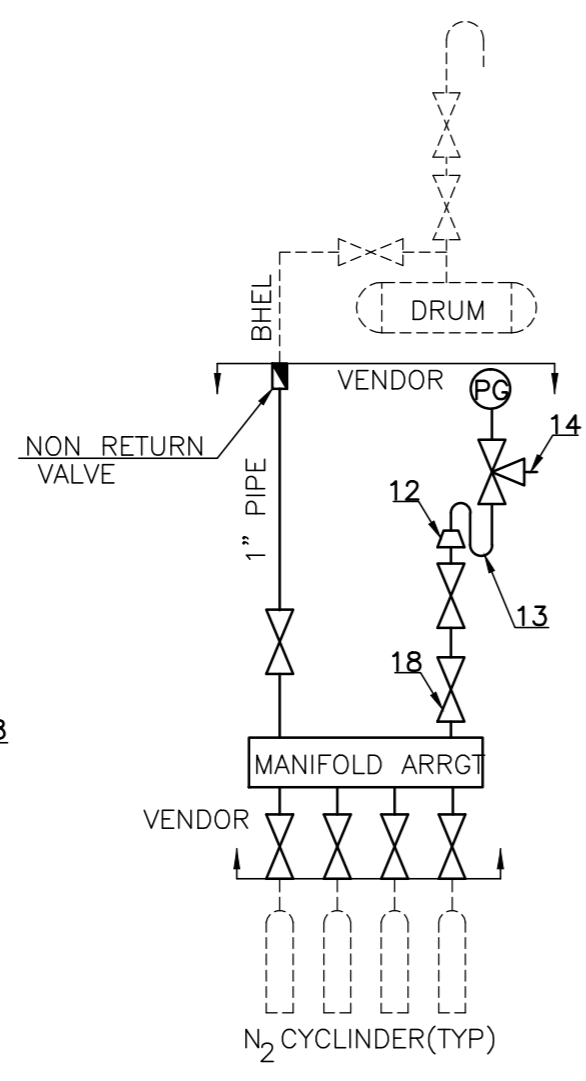
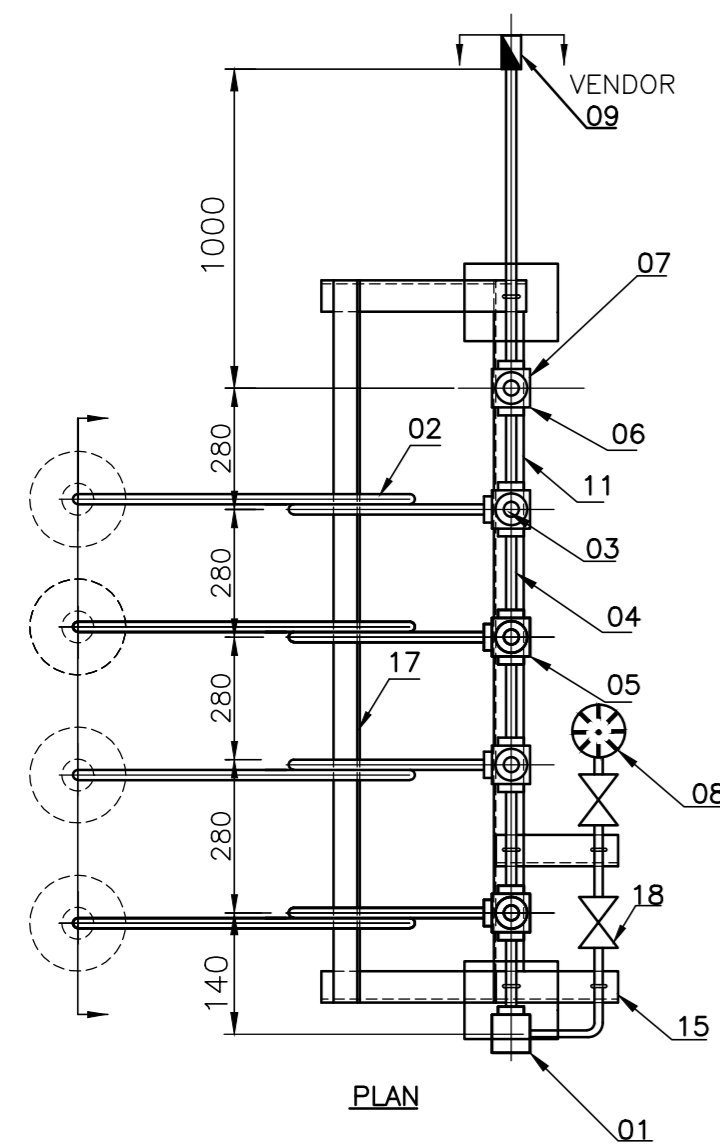

REV	DATE	ALTERED	M.N.DWIVEDI
01	18.12.13	CHKD & APPD	S.K.PRAKASH

CAUTION: The information on this document is the property of BHARAT HEAVY ELECTRICALS LTD. It must not be used directly or indirectly in any way detrimental to the interest of the company.

TYPE OF PRODUCT OR NAME OF CUSTOMER/PROJECT		NAME		DATE
Bharat Heavy Electricals Ltd UNIT: HIGH PRESSURE BOILER PLANT TIRUCHIRAPALLI - 620014		DRN	V.BASKAR	11.12.13
		CHD	S.K.PRAKASH	12.12.13
		APPD	N.KATHIRVEL	13.12.13
DEPT PCPS	ALL DIMENSIONS ARE IN MM	PROJECTION	SCALE	WEIGHT (Kg)
CODE 1322			N.T.S	
TITLE		DRAWING NO :		REV
NITROGEN BLANKETING SYSTEM		2-24-465-80991		01

Annexure II - Loading for deviation in Commercial terms

Payment Term (Indigenous)	
If materials are receivable at Project Sites without PBG	<p><u>Option-1:</u> Payment term is 100% direct payment after 45 days from the date of dispatch against site acknowledgement</p> <p><u>Option-2: (REVISED)</u></p> <p>a) Payment term is 100% direct payment after 45 days from the date of dispatch against site acknowledgement.</p> <p>(or)</p> <p>b) Payment term is 90% direct payment after 45 days from the date of dispatch against submission of dispatch documents and balance 10% against site acknowledgement. For this option –(b), a loading of 2% on the 90% of the offered value shall be made.</p>

Liquidated Damages / Penalty

Liquidated damages shall be 0.5% of the undelivered portion per week of the delay or part thereof subject to a maximum of 10% of the total order value.

Any deviation from the above LD clause, loading will be applied to the extent to which it is not agreed by the bidder (at offered value).

Vendor Sign & Seal



Annexure III - GENERAL TERMS

I. Enquiry / Request for Quotation (RFQ):

- (a) Any Purchase Order resulting from this enquiry shall be governed by **these general terms and conditions listed below and special terms and conditions, if any, along with this enquiry** of Bharat Heavy Electricals Limited, BHEL HPBP, Trichy-620014 (**hereinafter referred to as BHEL Trichy**).
- (b) Any of the terms and conditions not acceptable to supplier, shall be explicitly mentioned in the quotation. Otherwise, it will be treated as that all terms and conditions of this enquiry are acceptable.
- (c) If counter terms and conditions are offered by supplier, BHEL Trichy shall not be governed by such terms and conditions, unless it is agreed and incorporated in the Purchase Order of BHEL Trichy.
- (d) Any deviation to the terms and conditions not mentioned in the quotation by supplier in response to this enquiry will not be considered, if put forth subsequently or after issue of order, unless clarification is sought for by BHEL TRICHY and agreed upon in the Purchase Order of BHEL TRICHY.
- (e) BHEL TRICHY reserves the right to adopt Reverse Auction for the enquiry sent, at its discretion.
- (f) BHEL TRICHY shall be at liberty to cancel the tender at any time, before ordering, without assigning any reason.
- (g) The correspondence exchanged against the tender from both tenderer and BHEL through email are considered as valid document legally though it is not signed. It is treated as valid confirmations made on behalf of the respective company and very much comes under the legal ambit of the business transaction and hence it is binding on both the parties to the business.
- (h) Bidders participating in the tender should declare in their technical bid that whether they have been black-listed / kept on hold for a specified period / given Business holiday for a specified period by any Public sector undertaking or Government departments. The reasons for such action with details and the current status of such hold shall be clearly furnished to BHEL. If no such details are mentioned in the offer then it will be construed that the subject bidder is not under any such hold. But at a later date if it comes to the notice of BHEL about any such hold under enforcement on the subject bidder, BHEL will have every right to reject the offer of such vendors at any point of time and also under any stage of the finalization of the subject tender irrespective of the status of the subject bidder in that tender. Such bidders will not be permitted to participate in the further tender proceedings and will be communicated suitably. They will not be also considered for any ongoing tenders even if participated till the hold is officially lifted and confirmed in writing.



Bharat Heavy Electricals Limited

(A Govt. of India Undertaking)

AN ISO 9001

High Pressure Boiler Plant, Tiruchirappalli 620 014, India

Phone: (0431) 2577994

Fax: (0431) 2520719

COMPANY

E mail joydevsardar@bheltry.co.in

- (i) Risk purchase: - If the supplier fails to deliver the goods within the delivery specified in the Purchase Order, BHEL will be entitled to terminate the contract and to purchase elsewhere at the risk and cost of the seller either the whole of the goods or any part which the supplier has failed to deliver or dispatch within the delivery period mentioned in the Purchase Order.
- (j) All disputes or differences arises shall be subject to the exclusive jurisdiction of court within the limit of Trichy, TN.
- (k) Cartel Formation: - All the firms should desist from forming cartel as the practice is prohibited under Section 3(3) (a) & (d) of the competition Act 2002. If any such instance is observed during this tender will attract disciplinary action as per BHEL policies.

II. General Terms and conditions:

1. **TWO PARTS BID:** Quotation shall be submitted in two parts bid i.e.

(a) Techno-commercial i.e., Un-priced Bid:

Techno-commercial bid shall be submitted with complete description of the material, specification compliances to the enquired specification and all the commercial terms & conditions indicated in the **COMMERCIAL TERMS** attached to this tender. Any other enclosure, which the supplier wishes to submit like product catalogue, technical literature etc., may also be submitted in a sealed envelope super scribed clearly as "**TECHNOCOMMERCIAL BID**" with **RFQ No. and DUE DATE**. Un-priced copy of price bid (without price) shall also be enclosed with the techno-commercial bid.

Confirmation to BHEL specifications shall be indicated by the vendor in the respective columns provided in the purchase specification wherever applicable. Deviations to the specification / item description, if any shall be brought out clearly indicating "DEVIATION TO BHEL SPECIFICATION" without fail as a part of technical offer.

Suppliers who are not registered with BHEL Trichy must fill up online supplier registration form (SRF) and submit the copy of the filled SRF along with all the supporting documents. The SRF must be enclosed with techno-commercial bid. Offers without SRF may not be evaluated by us. Refer Annexure VI

Compliance to Pre-qualification criteria (if applicable) shall also be enclosed with the Techno commercial bid.

Manufacturer's name, their trade mark and brand, part number, alternate material to the one asked in enquiry, if any, should be mentioned in quotation and illustrative leaflets giving technical particulars etc. are to be attached to facilitate consideration and technical evaluation of the quotation.

BHEL TRICHY material code number (as in enquiry) shall be indicated for each item quoted.



Bharat Heavy Electricals Limited

(A Govt. of India Undertaking)

AN ISO 9001

High Pressure Boiler Plant, Tiruchirappalli 620 014, India

Phone: (0431) 2577994

Fax: (0431) 2520719

COMPANY

E mail joydevsardar@bheltry.co.in

(b) Price Bid:

Price bid should contain basic unit prices, discount if any, applicable taxes & duties, packing & forwarding charges (if applicable), Freight & insurances (if applicable) FOB charge (if applicable) etc., in a sealed envelope super scribed clearly as “**PRICE BID**” with **RFQ No. and DUE DATE**.

It is preferred to indicate the rates in both figures and words. In such case, if there is difference / discrepancy between the rates in figures and words, the **least of the two** rates will be considered.

2. Tender (quotation) shall be submitted in a sealed envelope super scribed with **RFQ NUMBER** and **DUE DATE** on it and the same must reach our office on or before the due date by **14:00 hrs.** Quotations are to be dropped in the tender box available at **Tender Opening Cell/MM, Room No.26, Ground Floor, 24 Building, BHEL Trichy-14, TAMIL NADU.** Quotations also can be dispatched by Couriers / Registered post / FAX / e mail to the Purchase Executive indicated in the RFQ.

Quotation through fax / email when addressed to the specific fax number and email address given in the enquiry, to be sent well in advance to enable BHEL TRICHY purchase personnel to drop in the tender box before the scheduled opening date and time. **Supplier is fully responsible for lack of secrecy on information of such quotations.**

BHEL TRICHY is not responsible for any delay in receipt of quotation sent by supplier through post / fax / email.

Late Tenders i.e., Tenders received after due date will be rejected.

3. The rates quoted against each item shall be in the same units stated in the enquiry. If the quotations are submitted in any other unit than specified, relationship between two sets of units must be furnished in the offer.
4. As far as possible, the quotations shall be free from corrections / overwriting. Corrections if any should be initialled with your seal and signature. Any typographical errors, totalling mistakes, currency mistakes, multiplication mistakes, summary mistakes observed in your priced bids, BHEL may consider whichever is beneficial to BHEL for evaluation.
5. Quotations are to be duly signed. Unsigned bids / offers are liable for rejection.
6. Tenders will be opened at **14:30 hrs.** & the venue is **Tender Opening Cell/MM, Room No.26, Ground Floor, 24 Building, BHEL Trichy-14, TAMIL NADU.** All the bidders or their authorized representatives (with authorization letter from their principals) can witness opening of tenders on the due date.
7. All the bids will be scrutinized for technical & commercial conformity.
8. The quantities in each item to be purchased may vary from quantities enquired according to the actual requirement at the time of placing the purchase order. Quantity discount if any should be mentioned in your offer.



Bharat Heavy Electricals Limited

(A Govt. of India Undertaking)

AN ISO 9001

High Pressure Boiler Plant, Tiruchirappalli 620 014, India

Phone: (0431) 2577994

Fax: (0431) 2520719

COMPANY

E mail joydevsardar@bheltry.co.in

9. BIDDERS (for indigenous purchase) shall indicate clearly Excise duty, Education cess, Sales Tax/VAT, Octroi, Exit/Entry tax, Service Tax as applicable for the quoted items. In the absence of clarity of these, any claim at a later date will not be entertained. Any changes in Taxes and duties after award of the contract will not be considered except such are those, which are imposed by Govt., notification within the contractual delivery. Seeking price amendments for change in Excise duty due to crossing of turnover limits will not be considered under any circumstances.

10. Payment of Agency Commission to Indian Agent (for foreign purchase):

i. BHEL shall deal directly with foreign vendors, wherever required, for procurement of goods. However, if the foreign principal desires to avail of the services of an Indian agent, then the foreign principal should ensure compliance to regulatory guidelines - which require mandatory submission of an Agency Agreement.

ii. It shall be incumbent on the Indian agent and the foreign principal to adhere to the relevant Guidelines of Government of India, issued from time to time.

iii. The Agency Agreement should specify the precise relationship between the foreign OEM / foreign principal and their Indian agent and their mutual interest in the business. All services to be rendered by agent/ associate, whether of general nature or in relation to the particular contract, must be clearly stated by the foreign supplier/ Indian agent. Any payment, which the agent or associate receives in India or abroad from the OEM, whether as commission or as a general retainer fee should be brought on record in the Agreement and be made explicit in order to ensure compliance to laws of the country.

iv. Any agency commission to be paid by BHEL to the Indian agent shall be in Indian currency only.

v. Tax deduction at source is applicable to the agency commission paid to the Indian agent as per the prevailing rules.

vi. In the absence of any agency agreement, BHEL shall not deal with any Indian agent (authorized representatives / associate / consultant, or by whatever name called) and shall deal directly with the foreign principal only for all correspondence and business purposes.

vii. The supply and execution of the Purchase Order (including indigenous supplies/ service) shall be in the scope of the OEM/ foreign principal. The OEM/ foreign principal should submit their offer inclusive of all indigenous supplies/ services and evaluation will be based on 'total cost to BHEL'. In case OEM/ foreign principal recommends placement of order(s) towards indigenous portion of supplies/ services on Indian supplier(s)/ agent on their behalf, the credentials/ capacity/ capability of the Indian supplier(s)/ agent to make the supplies/ services shall be checked by BHEL as per the extant guidelines of Supplier Evaluation, Approval & Review Procedure (SEARP), before opening of price bids. It will be the responsibility of the OEM/ foreign principal to get acquainted with the evaluation requirements of Indian supplier/ agent as per **SEARP available on www.bhel.com OR <http://vis.bheltry.co.in/olsa/>.**



Bharat Heavy Electricals Limited

(A Govt. of India Undertaking)

AN ISO 9001

High Pressure Boiler Plant, Tiruchirappalli 620 014, India

Phone: (0431) 2577994

Fax: (0431) 2520719

COMPANY

E mail joydevsardar@bheltry.co.in

The responsibility for successful execution of the contract (including indigenous supplies/ services) lies with the OEM/ foreign principal. All bank guarantees to this effect shall be in the scope of the OEM/ foreign principal.

11. TOTAL COST TO BHEL: Purchase order will be placed on the lowest bidder (L1) only among the technically & commercially accepted offers. Lowest Bid (L1) is determined on the basis of the total cost to BHEL.

(a) FOR INDIGENOUS PURCHASE:

Total cost to BHEL = Total basic value + Packing & forwarding charges + Excise duty Education cess + sales Tax/VAT + Octroi + Exit/Entry tax + Freight & Insurance + Service Tax (if applicable) + Loading factors for deviations to commercial terms & conditions.

12. FIRM PRICE: Rates quoted should be firm and no enhancement in the rates and changes in the techno-commercial terms will be allowed once the quotation is accepted and order is placed.

13. TERMS OF PAYMENT:

(a) FOR INDIGENOUS PURCHASE:

100% after 45 days from the date of receipt and acceptance of materials at site/stores as the case may be.

14. ADVANCE PAYMENT: Quotations with payment terms of “Advance” or “Inland Letter of Credit” will not be considered and such offers are liable for rejection commercially.

15. PENALTY:

- a Liquidated damages shall be 0.5% of the total order value per week or part thereof subject to a maximum of 10% of the total order value.
- b ~~For staggered delivery schedule, LD shall be 0.5% of the undelivered portion per week of the delay or part thereof subject to a maximum of 10% of the total order value.~~
- c Any deviation from the above LD clause, loading will be applied to the extent to which it is not agreed by the bidder (at offered value).

16. PBG: Applicable. 10% of the PO value to cover the Guarantee period.

17. WARRANTY/GUARANTEE: Guarantees shall be given for Eighteen months from the date of receipt of the material at Trichy Stores.

18. TERMS OF DELIVERY:

(b) FOR INDIGENOUS PURCHASE:



Bharat Heavy Electricals Limited

(A Govt. of India Undertaking)

AN ISO 9001

High Pressure Boiler Plant, Tiruchirappalli 620 014, India

Phone: (0431) 2577994

Fax: (0431) 2520719

COMPANY

E mail joydevsardar@bheltry.co.in

Material shall be delivered on FOR TRICHY/Stores basis, inclusive of packing & forwarding charges.

Packing shall be Road / Rail / Air / Sea worthy, best suitable for transshipment and to take care of transit damages.

Transit insurance shall be arranged by BHEL. Vendor shall intimate the dispatch details to BHEL immediately after effecting shipment, to arrange transit insurance accordingly.

19. DELIVERY REQUIREMENT: Material shall be delivered, as per the delivery schedule indicated in the RFQ. Indicate earliest firm delivery period in **NUMBER OF WEEKS or DAYS** by which materials will be dispatched from the date of receipt of purchase order.

20. VALIDITY: Quotation should remain valid for a period of **90 days** from the date of technical bid opening.

21. BHEL reserves the right to RE-FLOAT/REJECT/CANCEL the TENDER ENQUIRY (RFQ) without assigning any reason or cause thereof. Quotes received against this TENDER ENQUIRY are subject to and governed by all these terms and conditions. BHEL's decision will be final in awarding of the contract and binding on all vendors.

22. REVERSE AUCTION: Not Applicable.

23. POST-ORDER REQUISITES:

a) Pre-shipment inspection at vendor's works, if required, will be carried out by BHEL/ BHEL TPI agency. Required assistance will have to be provided by the vendor at the time of pre-shipment inspection.

b) Test certificates, Calibration certificates and warranty certificates as stipulated at the time of ordering shall be furnished.

c) Items shall be dispatched by Air/Road/Rail/Sea worthy packing. Any damage and later rejection, due to poor / improper packing shall be to supplier's account.

d) Any damage/rejection should be made good or replaced immediately without any extra cost to BHEL.

e) Original invoice (4 sets) to be submitted at BHEL Trichy for arranging payment.

24. Any dispute arising out of this contract shall be referred to the sole arbitration of Head of Materials Management, BHEL, TRICHY, Trichy or any other officer nominated by him and his decision shall be final and binding on the parties. The venue of the arbitration in all cases shall be Trichy.

25. All suits in respect of the above lie in the court of Jurisdiction of Trichy (India) only.

26. Material shall comply with the standard requirements of ISO 9001, 14001 & OHSAS 18001.



Bharat Heavy Electricals Limited

(A Govt. of India Undertaking)

AN ISO 9001

High Pressure Boiler Plant, Tiruchirappalli 620 014, India

Phone: (0431) 2577994

Fax: (0431) 2520719

COMPANY

E mail joydevsardar@bheltry.co.in

27. REGRET LETTER: In case, the supplier is unable / not willing to quote (for BHEL's registered vendors), a letter of regret shall be sent.

28. LOADING FACTORS:

Loading factors as detailed below will be added to the quoted price (basic) to evaluate the lowest quote for non-compliance of BHEL standard commercial terms.

A(i). For non-compliance of standard Terms of payment (For Indigenous Purchase Orders)

Sl. No.	BHEL standard term	If you quote	Loading factor in % for non-compliance
1	100% after 45 days from the date of receipt (credit payment)	(a) Payment through bank	Not acceptable
		(b) Payment against proforma invoice	Not acceptable
		(c) 100% after 45 days on receipt & acceptance of material.	Nil
		(d) LC payment terms	Offers will be rejected

B. For non-compliance of Penalty clause:

Sl. No.	BHEL standard term	If you quote	Loading factor for noncompliance
1	Penalty of 0.5% per week subject to max. of 10% on the basic value of the items not supplied /delayed	Not agreed.	10 %
		5% max., agreed.	5%
		Other than the above.	10% - (minus) agreed max. %

C. For Non-conformance to delivery requirement indicated in the RFQ:

Sl. No.	BHEL standard term	If you quote	Loading factor for noncompliance
1	Delivery requirement as indicated in the RFQ in number of weeks/days from the date of issue of PO.	Not agreed for the stipulated delivery in the enquiry	0.5 % per week up to max. of 10% for the difference in period

D (i) For Non- agreement on delivery at BHEL-TRICHY/SITE (For Indigenous Purchase Orders):



Bharat Heavy Electricals Limited

(A Govt. of India Undertaking)

AN ISO 9001

High Pressure Boiler Plant, Tiruchirappalli 620 014, India

Phone: (0431) 2577994

Fax: (0431) 2520719

COMPANY

E mail joydevsardar@bheltry.co.in

Sl. No.	BHEL standard term	If you quote	Loading factor for noncompliance
1	FOR Trichy Stores	Not agreed for the standard term of delivery	BHEL's cost for arranging transportation.

Annexure IV - Terms and conditions

Special terms & conditions for <u>INDIGENOUS vendors</u> to Enquiry no: 1801501287 dt.25.11.2015 for Supply of N2 Blanketing System		
Sl.no	Conditions	Vendor conformation
1	Offer shall be submitted in TWO PART bid i.e Technical offer with commercial terms & conditions in one envelope & price bid in another envelope, duly sealed.	
2	Offer should be valid for a minimum period of 90 days, from the date of Price Bid Opening.	
3	Tender will be finalized on the basis of "Total cost basis to BHEL".	
4	"Rate per number" to be quoted on " FOR-BHEL STORES,TRICHY " basis with price breakup indicating basic price, P&F, ED, CST/VAT, freight charges separately. Insurance will be in BHEL scope.	
5	If the vendor is not conforming to our technical / drawing requirements in total, their offer will not be considered for further evaluation in this tender.	
6	Delay in dispatches shall attract a penalty of Liquidated damages (LD) @ 0.5% per week, subject to maximum of 10%	
7	Lowest Prices received against BHEL tender need not be the technically acceptable one and in that case BHEL reserve the right not to consider the same	
8	Guarantee shall be given for Eighteen months from the date of receipt of the material at BHEL STORES,TRICHY or 24 months from then date of commissioning whichever is earlier.	
9	BHEL reserves the right to increase or decrease the tendered quantity.	

(Vendor Sign & Seal)

Annexure IV - Terms and conditions

Commercial Terms& conditions for INDIGENOUS vendors to Enquiry no: 1801501287 dt.25.11.15 for Supply of N2 Blanketing System			
SL NO	CONDITIONS	BHEL TERMS	Accepted/Not Accepted
1	Delivery Terms	FOR-BHEL STORES,TRICHY	
2	Delivery period	90 days from PO	
3	ED	Vendor to quote	
4	CST/VAT	Vendor to quote	
5	Freight	Vendor Scope	
6	Insurance	BHEL Scope	
7	LD	Delay in dispatches shall attract a penalty of Liquidated damages (LD) @ 0.5% per week, subject to maximum of 10%	
8	Risk Purchase	Applicable	
9	10% PBG (Performance Bank Guarantee)	Applicable to cover the guarantee period of 18/24 months.	
10	Payment terms	100% payment will be made after 45 days from the date of receipt and acceptance of material at BHEL STORES,TRICHY.	
11	Validity	90 days from the date of Price bid opening	
12	Firm Price	Firm Price	
13	PVC	Not Applicable	
14	Packing Forwarding	Vendor Scope	
15	Guarantee/Warranty	Guarantee shall be given for 18/24 months.	

(Vendor Sign & Seal)

Annexure V

Clause: Special Provisions for Micro and Small Enterprises (MSE):

1. 20% of the tendered quantity is earmarked for MSE suppliers in this tender.
2. Out of the 20% tendered quantity reserved for MSE suppliers, 4% shall be earmarked for procurement from MSE owned by SC / ST entrepreneurs.
3. In case MSE vendor participating in the tender quotes within the price band of L1 + 15%, they will be allowed to supply the portion of the requirement subject to acceptance of L1 price by MSE vendor. In case of more than one such MSE, the supply shall be shared proportionately.
4. MSE suppliers can avail the intended benefits only if they submit along with offer, attested copies of either EM II certificate having deemed validity (Two years from the date of issue of acknowledgement in EM II) or valid NSIC certificate or EM II certificate along with CA certificate (Format enclosed) applicable for the year, certifying quantum of investment in plant and machinery within the permissible limit as per the act for relevant status (Micro or small) where the deemed validity of EM II is over. Date to be reckoned for determining the deemed validity will be the last date of technical bid submission. Non submission of such documents will lead to consideration of their bids at par with other bidders and MSE status of such suppliers shall be shifted to Non MSE supplier till the supplier submits these documents.

NOTE: **Without requisite documents as mentioned in point 4 above, MSE status benefits will not be extended to vendors and these documents must be furnished along with the technical bid without fail.**

Annexure VI – SRF

Supplier Registration Form (SRF) has to be duly filled up online and send one copy with all the documents as mentioned in SRF. Offers with incomplete forms will not be entertained

URL for online Registration form is as below

<http://vis.bheltry.co.in/olsa/>

For any help regarding filling of SRF, you may contact following

1. Mr.M.Dharmalingam
(Addl.General Manager-Head-Supplier Development Cell)
Ph: 0431/2575459
Email ID: mdl@bheltry.co.in
2. Mr. Ebinesan
(Dy.General Manager - Supplier Development Cell)
Ph: 0431/2577448
Email ID: ebi@bheltry.co.in

Systems / BHEL / TRICHY

Ph: System SDC:0431/2577121, ljp@bheltry.co.in

Ph: System ERP:0431/2577522, erpsubcon@bheltry.co.in

For any queries regarding tender you may contact

1. Mr. Joydev Sardar
Engineer/MM/BOI
BHEL Trichy
Ph: 0431-2577994
joydevsardar@bheltry.co.in
2. Mr.S.Selvaraju
Senior Manager
MM/BOI
BHEL Trichy
Ph: 0431-2574087
ssraju@bheltry.co.in