



429-002/A

BHARAT HEAVY ELECTRICALS LIMITED

(A Government of India Undertaking)
HIGH PRESSURE BOILER PLANT
PURCHASE DEPARTMENT - FOSSIL BOILERS
THIRUCHIRAPALLI - 620014
TAMILNADU (INDIA)

Page
1/3

PHONE :2577419
GRAMS : BHARATELEC
FAX NO: 2520719
E-mail: cmuthuvel@bheltry.co.in
Web:

Enquiry No	Enquiry Date	Due Date for Quotation
1901600022 - 53	12.02.2016	27.02.2016
Please quote Enquiry No, Date and due date in all correspondences. This is only a request for quotation and not an order. Bid should be submitted in two parts. 1.Techno-commercial bid (Part-I) and 2.Price bid(Part-II) in a separate sealed cover and both covers must be placed in a third cover and sealed. Our Enquiry No., Enq. date & Enq. Due date must be written on all three covers.		

Item	Description	Unit	Quantity	Delivery Quantity	Schedule Date
10	200053830000 95 x 100 x 345 mm Collecting trough as per the Drawing number 4-7-0123-04-03503 /Rev 00	NO	21.000	21.00	21.03.16
20	200053840000 90 x 90 x 985 mm Collecting trough bottom wood linear as per drawing number 3-7-0103-11-01090 / Rev.No. 00	NO	11.000	11.00	21.03.16
30	200053850000 90 x 90 x 940 mm Collecting trough wood , bottom wood linear as per the drawing 4-7-0103-11-00987 / Rev No. 00	NO	11.000	11.00	21.03.16
40	200053860000 90 x 90 x 825 mm Collecting trough wood , bottom wood linear as per the drawing number 4-7-0103-11-00986 / Revision no. 00	NO	11.000	11.00	21.03.16
50	200053870000 90 x 120 x 900 mm Collecting trough bottom piece as per the drawing number 4-7-0111-13-03450 / Rev.No. 00	NO	17.000	17.00	21.03.16
60	200053880000 90 x 120 x 710 mm Collecting trough - Left Piece as per the drawing number 3-7-0111-13-02664 / Rev.no. 00	NO	17.000	17.00	21.03.16
70	200053890000 25 x 120 x 550 mm wood LEDGE and as per drawing number 4-7-0111-13-01570 / Rev.No.00	NO	21.000	21.00	21.03.16
80	200053880000 90 x 120 x 710 mm Collecting trough - Right Piece as per the drawing number 3-7-0111-13-02663 / Rev.no. 00	NO	17.000	17.00	21.03.16
90	200053820000	NO	21.000	21.00	21.03.16

The offers should reach us 30 minutes before the time of opening of tenders. The offers will be opened at 14.30 hrs on the due date of tender in the presence of tenderers who have submitted their offer and who may like to be present for the tender opening.Late and delayed offers are liable to be rejected.

Yours faithfully,
For **BHARAT HEAVY ELECTRICALS LIMITED**

R. KILLIVALAVAN
Engineer
PURCHASE / PSS MM
THIRUCHIRAPALLI - 620014.

MANAGER / PURCHASE
(FOSSIL BOILERS)
Yours faithfully,



BHARAT HEAVY ELECTRICALS LIMITED

(A Government of India Undertaking)
HIGH PRESSURE BOILER PLANT
PURCHASE DEPARTMENT - FOSSIL BOILERS
THIRUCHIRAPALLI - 620014
TAMILNADU (INDIA)

Page
2/3

PHONE :2577419
GRAMS : BHARATELEC
FAX NO: 2520719
E-mail: cmuthuvel@bheltry.co.in
Web:

1901600022 / 12.02.2016

23505

95 x 100 x 1290 mm Collecting trough as per
drawing number
4-7-0123-04-03502

General Note:

1. Offers received from MSE vendors only will be considered for this Enquiry.
2. Please submit your detailed offer in two part bid system i.e Part-I. Technical bid+ Annexure-A + Annexure-B + Annexure-N + Annexure-I and unpriced bid with indicating taxes & duties (Annexure-C) in a sealed cover super scribing on the cover as "TECHNICAL & COMMERCIAL BID / PART-I"
Part-II. Priced offer in another separate sealed cover super scribing on the cover as Part-II (Annexure-C)
- Both the covers shall be duly super-scribed with tender reference and due date of opening. These covers shall be put in a single cover duly super-scribed with tender reference and due date of opening and addressed to us.
3. Point-to-point confirmation to BHEL's specification and commercial terms & conditions shall be provided Annexure-A & B. All the Annexures should be filled and submitted along with the technical bid (no row shall be left blank), else your offer is liable for rejection.
4. Corrigendum if any, with respect to this tender will be hosted only in the website <http://www.bhel.com> or <http://tenders.gov.in>. You are requested to visit the website regularly for updates.
5. Vendors are requested to avoid the following points while submitting the Bid Documents:
 - a) Loose or spiral bound bid documents are not encouraged.
 - b) In case of any corrections/overwriting in the tender documents, the same shall be duly attested by the bid submitter.
6. Vendors representative having proper ID proof and authorization letter shall attend the tender opening.

List of Attachments:

1. Commercial Terms and Conditions - Annexure-A
2. Commercial Confirmations-Annexure-B
3. Price Format-Annexure-C
4. For New Vendors-Annexure-N
5. CA Certificate for MSE Vendors-Annexure-I

The offers should reach us 30 minutes before the time of opening of tenders.
The offers will be opened at 14.30 hrs on the due date of tender in the presence of tenderers who have submitted their offer and who may like to be present for the tender opening.Late and delayed offers are liable to be rejected.

R. KILLIVALAVAN
Manager
Purchase Department
Fossil Boilers
Thiruchirapalli - 620014
Tamil Nadu (India)

Yours faithfully,
For BHARAT HEAVY ELECTRICALS LIMITED

MANAGER / PURCHASE
(FOSSIL BOILERS)
Yours faithfully,



BHARAT HEAVY ELECTRICALS LIMITED

(A Government of India Undertaking)
HIGH PRESSURE BOILER PLANT
PURCHASE DEPARTMENT - FOSSIL BOILERS
THIRUCHIRAPALLI - 620014
TAMILNADU (INDIA)

Page
3/3
PHONE :2577419
GRAMS : BHARATELEC
FAX NO: 2520719
E-mail: cmuthuvel@bheltry.co.in
Web:

1901600022 / 12.02.2016

23505

All the tenders may be addressed to the following address:

**The Tender Opening Cell / MM
Room No: 26, Building 24, Ground Floor
Bharat Heavy Electricals Limited
TIRUCHIRAPALLI 620014**

In case personal delivery of the offer, it shall be dropped into the respective box kept in Room No: 26, after duly entering the data in the system.

Offers will be accepted only up to 14.00 Hrs on the due date. Therefore, vendors shall ensure to submit the offers well before this time. All due date extension requirements should be addressed to the respective Purchase mail IDs. All the due date extension requests from vendors will be considered only up to 48 hours before the due date and time.

Vendors are requested to avoid submission of offers through e mail / fax. In case of any unavoidable situation, offers shall be sent through e mail to the following mail ID only tender_cell@bheltry.co.in.

As tenders are being opened by Common Tender Opening Cell, offer covers should be sealed with tenderer's distinctive seal and super scribed with correct Tender No. item of supply and due date of opening.

The offers will be opened at 14.30 hrs on the due date of the tender in the presence of tenderers who have submitted their offer and who may like to be present for the tender opening. Late and delayed offers are liable to be rejected.

The bidder along with its associate/ collaborators/ sub-contractors/ sub-vendors/ consultants/ service providers shall strictly adhere to BHEL fraud prevention policy displayed on BHEL website <http://www.bhel.com> and shall immediately bring to the notice of BHEL management about any fraud or suspected fraud as soon as it comes to their notice.

Enclosures:

"LD clause has to be confirmed without fail."

The offers should reach us 30 minutes before the time of opening of tenders.
The offers will be opened at 14.30 hrs on the due date of tender in the presence of tenderers who have submitted their offer and who may like to be present for the tender opening. Late and delayed offers are liable to be rejected.

R. KILLIVALAVAN
Engineer
PURCHASE / PSS / MM
BHEL, TRICHY - 620014.

Yours faithfully,
For **BHARAT HEAVY ELECTRICALS LIMITED**

MANAGER / PURCHASE
(FOSSIL BOILERS)
Yours faithfully,

ANNEXURE – A

TERMS AND CONDITIONS

1. The tender will be operated on two part bid basis i.e.
 - I. Techno-Commercial Bid &
 - II. Price Bid
2. The offer is to be submitted in a single envelope containing two envelopes. i.e. Part - I (Techno Commercial Bid) and Part - II (Price Bid).
3. **Part – I (Techno-Commercial Bid):**
 - I. Duly Signed Tender Document
 - II. Duly signed Annexure – A (Terms and Conditions)
 - III. Duly filled & signed Annexure – B (Techno Commercial Bid)
 - IV. Signed and **unfilled** Annexure – C (**Price Bid-indicating taxes & duties without prices**)
 - V. Signed and filled Annexure – N (**Applicable for New Vendors only**. Supporting documents should be submitted along with this bid)

This Part – I document should be sealed in a separate envelop by clearly marked “Part I – Technical and Un-priced commercial bid” indicating Enquiry No., Due Date., address & reference of the bidder.

4. **Part – II (Price Bid):**
 - I. Duly filled and signed Annexure – C (Price Bid)

This price bid should be sealed in a separate envelope by clearly marked “Part II – Price bid” indicating Enquiry No., Due Date., Address & reference of the bidder.

5. You are requested to put the above two envelopes (Techno-Commercial Bid & Price Bid) inside a separate larger sealed envelope and this envelope shall be super scribed as “Techno-Commercial Bid and Price Bid “ for Enquiry No:Dt: Due Dt:
6. Your offer should be addressed to:
**Tender Opening Cell/MM,
Room No 26,
24 Building (Ground Floor),
Bharat Heavy Electricals Limited,
Tiruchirappalli - 620 014.**
7. Any clarifications related to the enquiry should be addressed to kvalavan@bheltry.co.in and tender number should be mentioned in the subject. Any clarifications without the reference of tender number in the subject will not be entertained.
8. The offer should reach this office on or before the due date as mentioned in the enquiry by 14.00 Hrs. Tenders received after 14.00 Hrs will not be considered for evaluation. Offers through E-Mail/Fax will not be accepted.
9. Any techno commercial clarifications/request for tender due date extensions with valid acceptable reasons to be addressed to BHEL prior to 48 hours of tender due date. BHEL reserves the rights to extend the due date as per their discretion.
10. Tender document will be opened on the due date as given in the enquiry and if the due date falls on holiday, the tender documents will be opened immediately on the next working day.
11. Each tender should be sealed with tenderer's distinctive seal and super scribed with correct tender no., item of supply and due date of opening. Two or more quotation should not be sent in one cover but the quotation against each tender should be sent separately to avoid confusion. Tender should not be addressed to any individual's name but only by designation.

12. Tenders should be free from CORRECTION AND ERASURES. Corrections if any must be attested; all amounts shall be indicated both in words as well as in figures. Where there is difference between amount quoted in words and figures, amount quoted in words shall only be considered.

13. Discrepancy in “Words “& “Figures “

- a. If, in the price structure quoted for the required goods/services/works, there is discrepancy between the unit price and the total price (which is obtained by multiplying the unit price by the quantity), the unit price shall prevail and the total price corrected accordingly, unless in the opinion of the purchaser there is an obvious misplacement of the decimal point in the unit price, in which case the total price as quoted shall govern and the unit price corrected accordingly.
- b. If there is an error in a total corresponding to the addition or subtraction of subtotals, the subtotals shall prevail and the total shall be corrected; and
- c. If there is a discrepancy between words and figures, the amount in words shall prevail, unless the amount expressed in words is related to an arithmetic error, in which case the amount in figures shall prevail subject of (a) and (b) above.

14. No revision of prices will be entertained after tenders are opened.

15. Validity of quoted rates shall be valid minimum at least 90 days from the date of technical bid opening. The quoted/Finalized rates shall be Firm till completion of the supplies.

16. The rates are to be quoted on F.O.R. destination basis only (Inclusive of Packing, Forwarding, and Freight and Transit Insurance charges to supplier account). Other delivery conditions like Ex-works / Ex-Godown/ Transportation of materials through transport carriers from your works up to the transport carrier's office at Tiruchy and taking delivery of goods by BHEL from such office of transport carriers is not acceptable to us and such offers will be summarily rejected.

17. Please submit point wise compliance to our specifications, terms and conditions. Otherwise it will be presumed that you are accepting BHEL's terms and conditions.

18. Unloading at BHEL Site has to be done by the suppliers and BHEL will not be in a position to provide any handling / unloading facilities.

19. Payment Terms (Indigenous):-

Payment term is 100% direct payment after 45 days from the date of receipt and acceptance of materials. Any deviation in the above payment term will attract loading as mentioned below.

“Base rate of SBI (as applicable on the date of bid opening. Techno-commercial bid opening in case of two part bids) + 6% shall be considered for loading for the period of relaxation sought by bidders.

20. Liquidated Damages / Penalty:-

(Any deviations in the LD shall attract loading to the extent of relaxation sought to which it is not agreed by the bidder at offered value).

Single delivery schedule: If the Supplier fails to deliver the P.O quantity within the period specified in the PO, then the Purchaser shall deduct liquidated damages, 0.5% of the total order value per week of delay or part thereof subject to a maximum of 10% of the total order value.

~~In case of staggered delivery schedule, if the Supplier fails to deliver the quantity of any line item of the P.O within the period specified in that line item, Purchaser shall deduct Liquidated Damages, 0.5% of the undelivered portion per week delay or part thereof subject to maximum of 10% of the total order value~~

21. Ranking L-1, L-2 etc. shall be done for individual items for the techno-commercially acceptable offers based on the landed cost to BHEL, Trichy and BHEL reserves the right to place order for individual items with different vendors.

22. In the event of more than one vendor becoming L1 for any of the item / items, BHEL reserves the right to negotiate with those vendors and order will be placed on the vendor who offers lowest acceptable price to BHEL.

23. If any sales tax is payable as extra to the quoted price it should be specifically stated in quotations along with CST & VAT Number failing which the purchaser will not be liable for payment of sales tax. Our TIN 33243560005 dt.01.01.2007 & CST no 239383 DT, 11.06.1991.

24. On the due date of tender opening, only the technical bids will be opened. Technical bids will be evaluated by us and clarifications required, if any, will be called for from the bidders on technical and commercial points. The price bids of techno-commercially suitable bidders will be opened on a later date with prior intimation to respective bidders.

25. Lowest price received against BHEL tenders need not be the technically acceptable one and in that case BHEL reserves the right not to consider the same. The purchaser shall be under no obligation to accept the lowest or any other tender and shall be entitled to accept or reject any tender in part or full without assigning any reason whatsoever.

26. BHEL reserves the right to negotiate or re-float the tender opened if L1 price is not the lowest acceptable price to them inter-alia other reasons.

27. BHEL deserves the right to increase or decrease the tendered quantity.

28. Risk Purchase:

Alternatively the purchaser at his option will be entitled to terminate the contract and to purchase elsewhere at the risk and cost of the seller either the whole of the goods or any part which the supplier has failed to deliver or dispatch within the time stipulated as aforesaid or if the same were not available, the best and the nearest available substitutes therefore. The supplier shall be liable for any loss, which the purchaser may sustain by reason of such risk purchases in addition to penalty at the rate mentioned in our LD clause.

29. SPECIAL PROVISIONS FOR MICRO AND SMALL ENTERPRISES (MSE) BIDDERS:

- i. MSE suppliers can avail the intended benefits only if they submit along with the offer, attested copies of either EM II certificate having deemed validity (five years from the date of issue in acknowledgement in EM II) or valid NSIC certificate or EM II certificate along with attested copy of a CA certificate (Format enclosed as per **Annexure I** where deemed validity of EM II certificate of five years have expired) applicable for the relevant financial year (latest audited). Date to be reckoned for determining the deemed validity will be the date of bid opening (Part 1 in case of two part bid). Non submission of such documents will lead to consideration of their bids at par with other bidders. No benefits shall be applicable for the enquiry if any deficiency in the above required documents is not submitted before the price bid opening. If the tender is to be submitted through e-procurement portal, then the above required documents are to be uploaded on the portal. Documents should be notarized or attested by a Gazetted officer. This provision for MSE will apply subject to the condition that the participating MSE meets the tender requirements.
- ii. In case of any change in the MSE status of the bidder, it shall be the responsibility of the bidder to notify the change as a part of the bid document. If at a later date it comes to the knowledge of BHEL, that the change in the status has not been intimated by the bidder and the order is obtained under the premise of an MSE then BHEL would cancel the pending order against this tender and take necessary steps for suspension of the business dealing with the bidder as per the procurement policy of BHEL.

30. Cenvat Credit:

If any Excise Duty is payable, the Chapter Head / Sub -head reference and the rate of the duty should be quoted. If the Tenderer is availing CENVAT credit for this input material, the effect of Proforma credit should be passed on to the purchaser. Tenderer under "CENVAT" shall be preferred.

31. Any other conditions which might have been quoted by the seller and are in contravention to the terms prescribed in the order and which have not been specifically accepted in by purchaser will not be applicable to the contract.
32. Bidders not confirming to the enquiry specification mentioned will be disqualified.
33. Any corrigendum related to the enquiry will be hosted in the BHEL website only, Bidders should visit the website(s) to keep themselves updated.
34. The correspondence between the bidder and BHEL through email is considered as valid document legally though not signed. It is treated as valid confirmations made on behalf of the respective company and comes under the legal ambit of the business transaction and hence binding on both the parties.
35. Bidders participating in the tender should declare in their technical bid whether they have been black-listed / kept on hold / given Business holiday for a specified period by any Public Sector Undertaking or Government Departments. The reasons for such action with details and the current status of such hold shall be clearly furnished to BHEL. If no such details are mentioned in the offer, it will be construed that the bidder is not under any such hold. However, at a later date if it comes to the notice of BHEL about any such hold under enforcement, BHEL reserves the right to reject the offer at any point of time and also under any stage of the finalization of the tender. Such bidders will not be permitted to participate in the further tender proceedings and will be communicated suitably.

**COMMERCIAL TERMS CONFIRMATION REQUIRED FROM THE SUPPLIERS
TO BE SUBMITTED ALONG WITH PART – I (TECHNO COMMERCIAL BID)
ANNEXURE – B**

S. NO	DESCRIPTION	BHEL REQUIREMENTS	SUPPLIER CONFIRMATION / DEVIATION (STRIKEOUT WHICHEVER IS NOT APPLICABLE)
1	VALIDITY	90 DAYS FROM THE BGDATE OF TECHNICAL BID OPENING	NON DEVIATABLE
2	PRICE QUOTED	FOR-DESTINATION BHEL STORES / TRICHY	NON DEVIATABLE
3	EXCISE DUTY WITH CESS	SUPPLIER OPTION	INCLUSIVE / EXTRA % _____
4	VAT / CST against form 'C'	SUPPLIER OPTION	INCLUSIVE / EXTRA _____ %
5	DEIVERY SCHEDULE	SINGLE DELIVERY FROM THE DATE PO-20 days	NON DEVIATABLE
6	PAYMENT TERMS	AFTER 45 Days FROM THE DATE OF RECEIPT AND ACCEPTANCE OF MATERIALS AT BHEL (For details please read S.No:19 of "Annexure – A")	ACCEPTED / NOT ACCEPTED
7	LD CLAUSE	0.5% PER WEEK TO MAXIMUM OF 10% (For details please read S.No:20 of "Annexure – A")	NON DEVIATABLE
8	RISK PURCHASE CLAUSE	(For details please read S.No:28 of "Annexure – A")	NON DEVIATABLE
9	PRICE VARIATION	NO PRICE REVISION SHALL BE ENTERTAINED TILL COMPLETION OF ORDERED QUANTITY INCLUDING EXTENSION / VARIATION IF ANY.	NON DEVIATABLE
10	CONTACT PERSON DETAILS	NAME: MOBILE NO: EMAIL :	To be filled mandatorily
11	<u>CONFIRMATION OF SPECIFICATION:</u> KONGU WOOD COLLECTING TROUGHS AS PER ENQUIRY SPEC.		CONFIRM / NOT CONFIRM
12	2 Copies of Test Certificate are to be enclosed along with DC.		CONFIRM / NOT CONFIRM
13	Bidders have to confirm that, whether they have been black-listed / kept on hold / given Business holiday for a specified period by any Public Sector Undertaking or Government Departments/any other units of BHEL. (With reference to S.No.35 of Annexure – A).		YES / NO
14	Offers received from MSE vendors only will be considered for this Enquiry.		NON DEVIATABLE
15	Documents as called in Sl.No.29 of terms & conditions attached (MSE Status)		ATTACHED / NOT ATTACHED

IMPORTANT NOTE:

Item wise confirmation of this format is essential to consider your offer.

SIGN AND SEAL OF THE AUTHORIZED
PERSON TO SIGN THE TENDER DOCUMENT

**BHARAT HEAVEY ELECTRICALS LIMITED
TIRUCHIRAPPALLI - 620 014**

ANNEXURE - C

PRICE BID FORMAT

ENQUIRY NO:

DATE:

DUE DATE:

ENQ SL NO	MATERIAL CODE	MATERIAL DESCRIPTION	DRG.NO	QTY	BASIC PRICE INCLUSIVE OF PACKING & FORWARDING, FREIGHT & INSURANCE AND DISCOUNT	EXCISE DUTY IN %	SALES TAX IN %			OTHER COST IF ANY IN %
							VAT %	CST WITH C FORM %	CST WITHOUT C FORM %	
10	200053830000	95 x 100 x 345 mm Collecting trough	4-7-0123-04-03503 /Rev 00	21						
20	200053840000	90 x 90 x 985 mm Collecting trough	3-7-0103-11-01090 / Rev.No. 00	11						
30	200053850000	90 x 90 x 940 mm Collecting trough	4-7-0103-11-00987 / Rev No. 00	11						
40	200053860000	90 x 90 x 825 mm Collecting trough	4-7-0103-11-00986 / Rev. no. 00	11						
50	200053870000	90 x 120 x 900 mm Collecting trough	4-7-0111-13-03450 / Rev.No. 00	17						
60	200053880000	90 x 120 x 710 mm Collecting trough-left	3-7-0111-13-02664 / Rev.no. 00	17						
70	200053890000	25 x 120 x 550 mm Collecting trough	4-7-0111-13-01570 / Rev.No.00	21						
80	200053880000	90 x 120 x 710 mm Collecting trough-right	3-7-0111-13-02663 / Rev.no. 00	17						
90	200053820000	95 x 100 x 1290 mm Collecting trough	4-7-0123-04-03502	21						

SIGN AND SEAL OF AUTHORIZED PERSON

**BHARAT HEAVEY ELECTRICALS LIMITED
TIRUCHIRAPPALLI - 620 014**

**ANNEXURE - N
(FOR NEW VENDORS ONLY)**

Sl No	Details	Document Submission
1	Nature of ownership & relevant documents	
	<u>Proprietorship</u>	
	Professional Tax Regn	YES / NO
	Municipal Regn	YES / NO
	<u>Partnership firm</u>	
	Partnership Deed	YES / NO
	<u>Co-operative society</u>	
Society rules & bye laws	YES / NO	
<u>Private/Limited Company</u>		
Memorandum & Articles of Association	YES / NO	
<u>State Govt. / Govt. Of India Undertaking</u>		
Memorandum & Articles of Association	YES / NO	
2	Nature of Business (Manufacturing Unit) (Indian Subsidiary - attach authorization certificate of principal)	YES / NO
2	Manufacturing range & facilities: (If applicable) • List down the product range & specification details. • List of Manufacturing facilities/equipment's (including material handling facility)	YES / NO
3	Licence details of the factory	YES / NO
4	• Permanent Account No	YES / NO
	• Central Sales Tax registration number	YES / NO
	• State Sales Tax / TIN number	YES / NO
	• Excise Duty Registration number	YES / NO
	• Excise Control Code number	YES / NO
	• Service tax registration number	YES / NO
• Regn number of category as per MSMED Act (If applicable)	YES / NO	
5	If registered with any other BHEL unit • Letter of registration with BHEL unit (If applicable)	YES / NO
6	Accreditation certificate for ISO:9001 / TOC of Quality System manual / ISO:14000 / OHSAS ISO 18000 (If applicable)	YES / NO

Certificate by Chartered Accountant on letter head

This is to Certify that M/S
(hereinafter referred to as 'company') having its registered office at
is registered under MSMED Act 2006, (Entrepreneur
Memorandum No (Part-II) dtd:.....,
Category: (Micro/Small)). (Copy enclosed).

Further verified from the Books of Accounts that the investment of the company as on
date..... as per MSMED Act 2006 is as follows:

1. **For Manufacturing Enterprises:** Investment in plant and machinery (i.e. original cost
excluding land and building and the items specified by the Ministry of Small Scale Industries vide its
notification No.S.O.1722(E) dated October 5, 2006 :
Rs.....Lacs
2. **For Service Enterprises:** Investment in equipment (original cost excluding land and building and
furniture, fittings and other items not directly related to the service rendered or as may be notified under the MSMED
Act, 2006:
Rs.....Lacs

The above investment of Rs.....Lacs is within permissible limit of
Rs.....Lacs forMicro / Small (~~Strike off which is not applicable~~)
Category under MSMED Act 2006.

Date:

(Signature)

Name -

Membership number -

Seal of Chartered Accountant

FIRST ANGLE PROJECTION (ALL DIMENSIONS IN MILLIMETRES)

05-249/B

CAUTION THE INFORMATION ON THIS DOCUMENT IS THE PROPERTY OF BHARAT HEAVY ELECTRICALS LTD. IT MUST NOT BE USED DIRECTLY OR INDIRECTLY IN ANY WAY DETRIMENTAL TO THE INTEREST OF THE COMPANY

REV. 01	DATE	ALTERED
		CHECKED
ZONE		

2

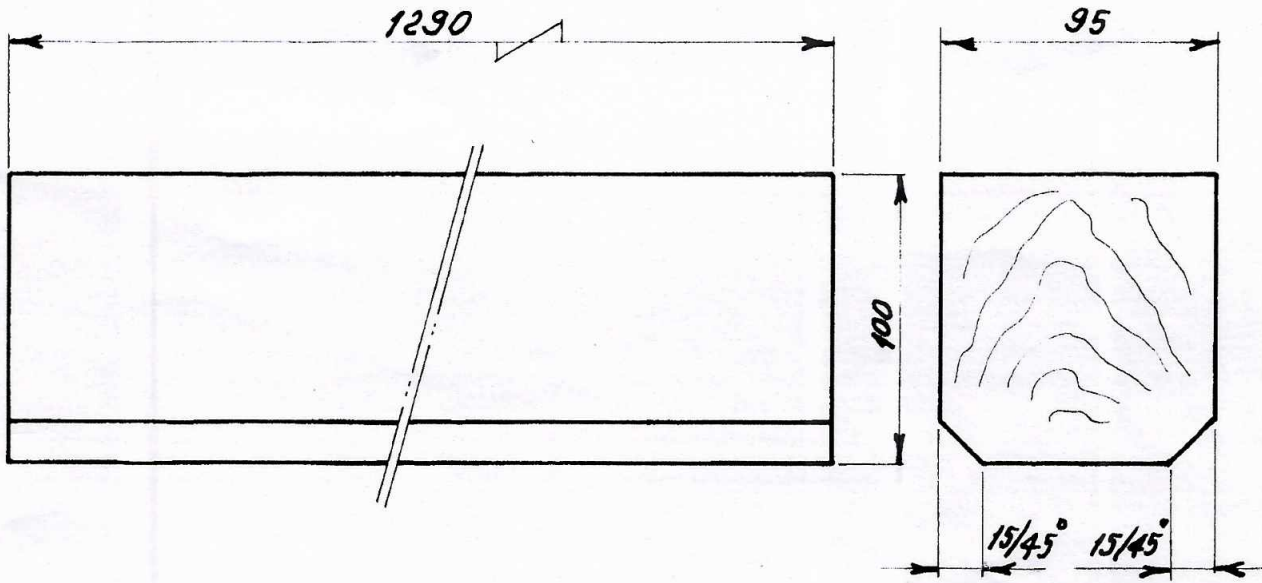

		HARD WOOD	
		(KONGOR) (ERU)	
ITEM NO.	DESCRIPTION	MATL. CODE	UNIT WT.
		MATL. SPEC	QTY.

EQPT:- NORMALISING AND TEMPERING FURNACE



Bharat Heavy Electricals Ltd.,
SEAMLESS STEEL TUBE PLANT
TIRUCHIRAPALLI-620 014

DRN.	NAME	SIGN	DATE
CHR	A. AROCKIAM	[Signature]	21-07-1987
APPD.	[Signature]	[Signature]	22-7-87

DEPT.	GRADE OF UNTOLED.DIM. C/M/F	SCALE	WEIGHT (K9)	REF. TO ASSY./DRG.	ITEM NO.
CODE		1:2.5	8,64	1-7-0123-04-01206	03
TITLE			CARD CODE	DRAWING NO.	REV.
WOOD INSERT			U 01	4-7-0123-04-03502	00

FIRST ANGLE PROJECTION (ALL DIMENSIONS IN MILLIMETRES)

05-249/B

CAUTION THE INFORMATION ON THIS DOCUMENT IS THE PROPERTY OF BHARAT HEAVY ELECTRICALS LTD. IT MUST NOT BE USED DIRECTLY OR INDIRECTLY IN ANY WAY DETRIMENTAL TO THE INTEREST OF THE COMPANY

REV.	DATE	ALTERED
01		CHECKED
ZONE		

φ13
3 NOS.

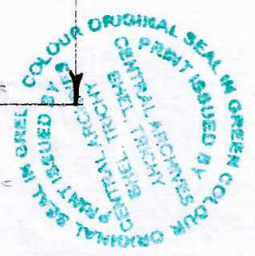
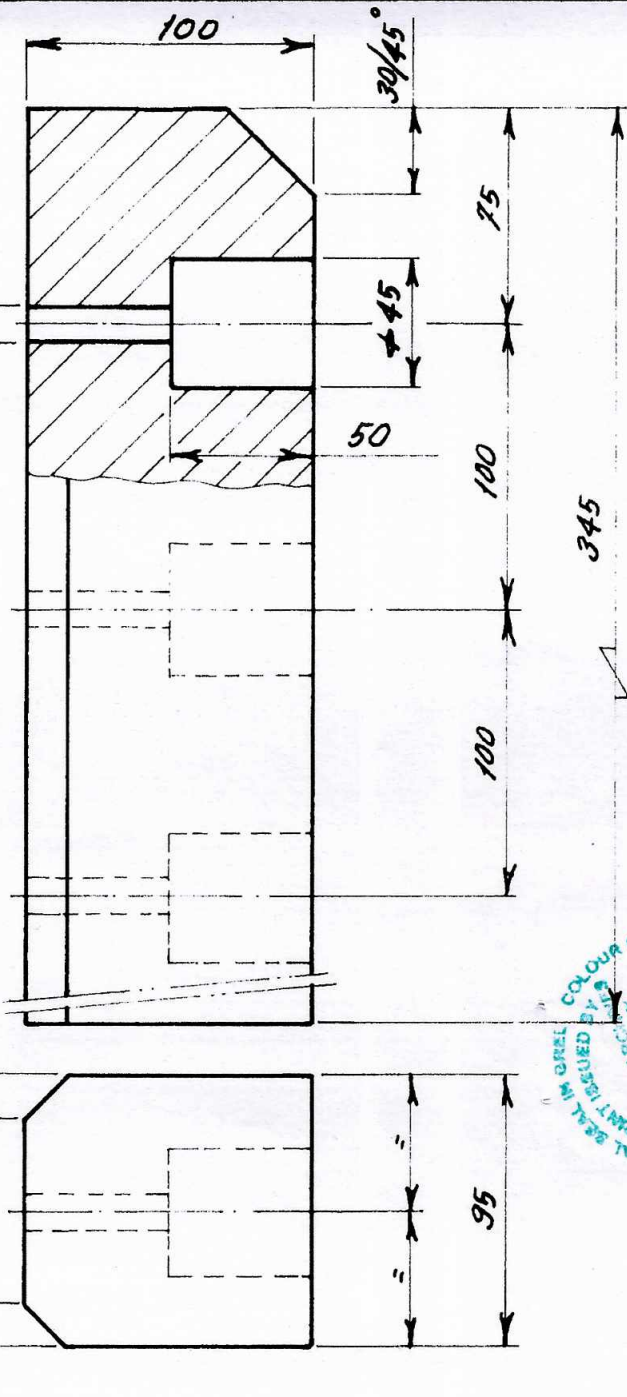

ITEM NO.	DESCRIPTION	HARD WOOD	
		KON 600 (or) EQUIVALENT	
		MATL. CODE	UNIT WT.
		MATL. SPEC	QTY.

EQPT:-NORMALISING AND TEMPERING FURNACE

	Bharat Heavy Electricals Ltd., SEAMLESS STEEL TUBE PLANT TIRUCHIRAPALLI-620 014		DRN.	NAME	SIGN	DATE
			CHR	K-NATARAJAN	<i>K. Natarajan</i>	21-07-1987
			APPD.	A-ARICKAM	<i>A. Arickam</i>	22-7-87

DEPT.	GRADE OF UNTOLED. DIM. C/M/F	SCALE	WEIGHT (Kg)	REF. TO ASSY./DRG.	ITEM NO.
		1:2.5	2,29	1-7-0123-04-01206	04

TITLE	CARD CODE	DRAWING NO.	REV.
WOOD INSERT	U 01	4-7-0123-04-03503	00

FIRST ANGLE PROJECTION (ALL DIMENSIONS IN MILLIMETRES)

05-249 / B

CAUTION THE INFORMATION ON THIS DOCUMENT IS THE PROPERTY OF BHARAT HEAVY ELECTRICALS LTD. IT MUST NOT BE USED DIRECTLY OR INDIRECTLY IN ANY WAY DETRIMENTAL TO THE INTEREST OF THE COMPANY.

REV 01	DATE	ALTERED
		CHECKED
ZONE		

2

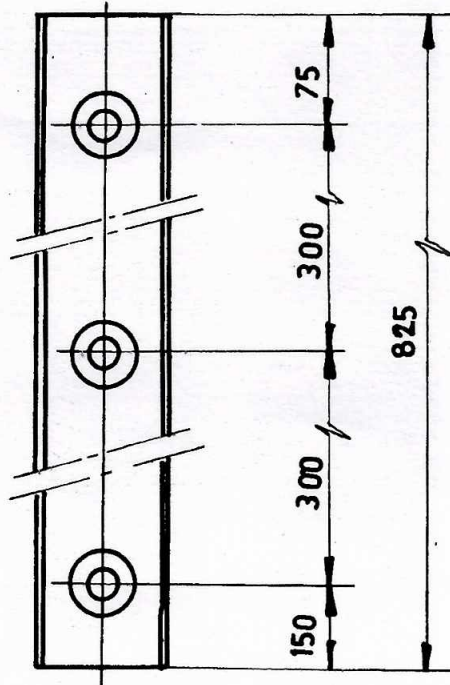
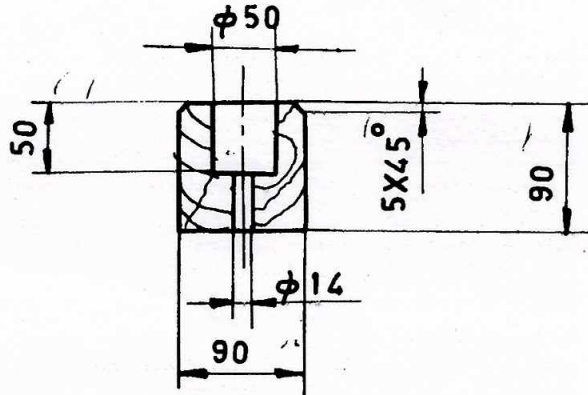

		HARD WOOD KONGOO OR EQUIVALENT.	
ITEM NO.	DESCRIPTION	MATL CODE	UNIT WT
		MATL SPEC	QTY

EQPT: PUSH POINTING PRESS PST. 63/150 RZS WITH FACILITIES.



Bharat Heavy Electricals Ltd.,
SEAMLESS STEEL TUBE PLANT
TIRUCHIRAPALLI-620 014

DRN	NAME	SIGN	DATE
CHD	A. ARACKIAR	A. Jothi	11.6.87
APPD		[Signature]	11.06.87

DEPT	GRADE OF UNTOL. DIM	SCALE	WEIGHT (kg)	REF TO ASSY / OLD DRG	ITEM NO.
CODE	C/M/F	1:5	4,75	03011 69 - 12-217	
TITLE			CARD CODE	DRAWING NO.	REV.
WOOD LINER			U 01	4-7-0103-11-00986	00

FIRST ANGLE PROJECTION (ALL DIMENSIONS IN MILLIMETRES)

05-249 / B

CAUTION THE INFORMATION ON THIS DOCUMENT IS THE PROPERTY OF BHARAT HEAVY ELECTRICALS LTD. IT MUST NOT BE USED DIRECTLY OR INDIRECTLY IN ANY WAY DETRIMENTAL TO THE INTEREST OF THE COMPANY.

REV 01	DATE	ALTERED
		CHECKED
ZONE		

2

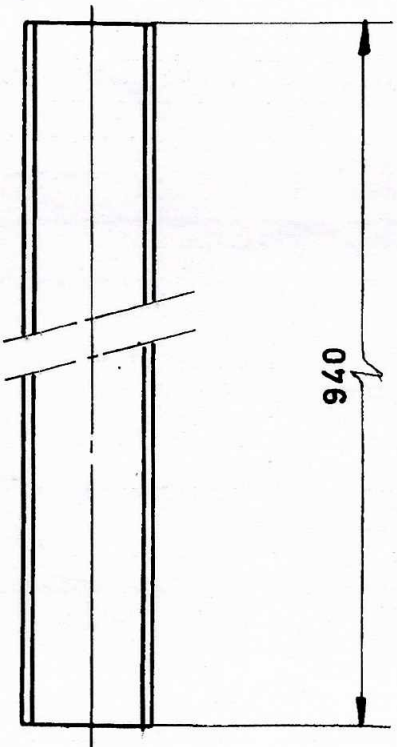
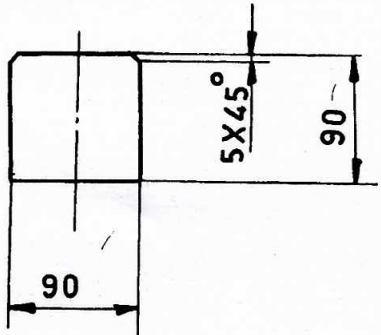

ITEM NO.	DESCRIPTION	MATL CODE	UNIT WT
		MATL SPEC	QTY

HARD WOOD KONGOO OR EQUIVALENT.

EQPT: PUSH POINTING MACHINE WITH TRANSPORT FACILITIES.



Bharat Heavy Electricals Ltd.,
SEAMLESS STEEL TUBE PLANT
TIRUCHIRAPALLI-620 014

DRN	NAME	SIGN	DATE
CHD	A. ARSCKIAM	J. JNNL	11-6-87
APPD			11.06.87

DEPT	GRADE OF UNTOL. DIM C/M/F	SCALE	WEIGHT (kg)	REF TO ASSY/OLD DRG	ITEM NO.
CODE		1:5	5,20	0301169 - 12.218	
TITLE			CARD CODE	DRAWING NO.	REV.
WOOD LINER			U 01	4-7-0103-11-00987	00

FIRST ANGLE PROJECTION (ALL DIMENSION ARE IN M.M.)

REV	DATE	ALTERED	REV	DATE	ALTERED
		CHECKED			CHECKED

CAUTION: THIS DRAWING IS OUR SOLE PROPERTY AND SHOULD NOT BE USED IN ANY FORM FOR ANY OTHER PURPOSE WITHOUT THE WRITTEN PERMISSION OF BHARAT HEAVY ELECTRICALS LTD., TIRUCHIRAPALLI-14

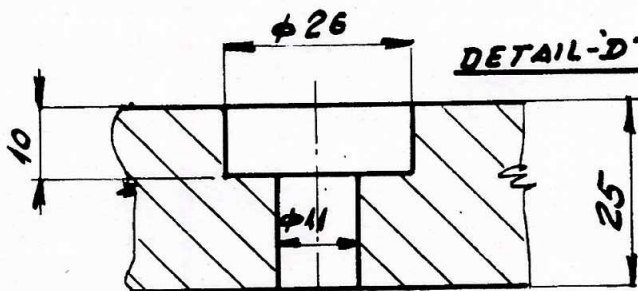
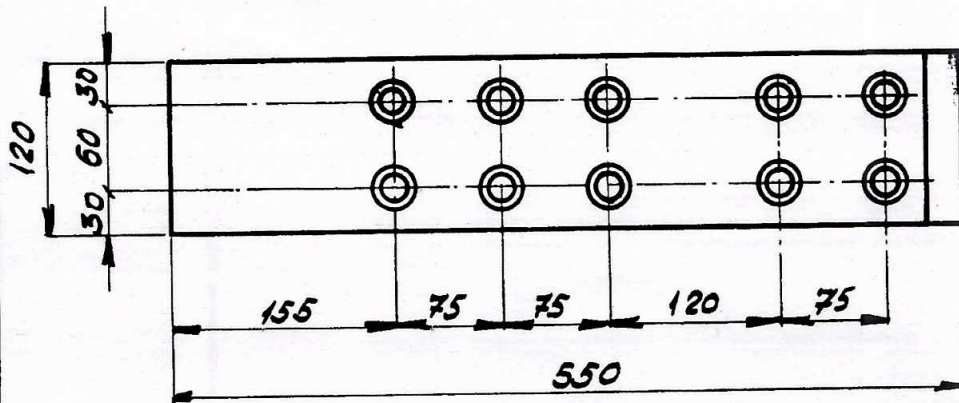
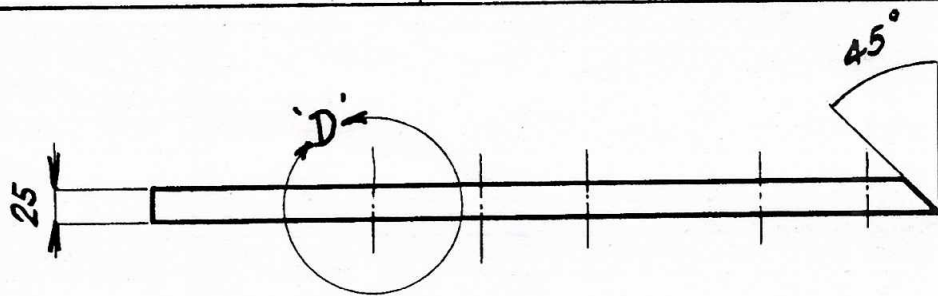

MATL. HARD WOOD

DESCRIPTION	ITEM NO.	STD	DRAWING NO.	MATERIAL CODE	COMP. GROUP	UNIT Wt.(Kg)	EMI/GRSP
				MATERIAL SPECN.		QTY	



EQPT: 80 T DRAW BENCH
BHARAT HEAVY ELECTRICALS LIMITED.

DEPT	CODE		SCALE	WEIGHT (Kg)	REF. TO ASSY DRG. SSTP-1M-186	ITEM NO.
------	------	--	-------	-------------	----------------------------------	----------

TITLE WOOD LEDGE	DRAWN	NAME S Pandian	SIGN	DATE 13.10.78
	CHECKED			
	APPROVED			

DIMENSIONS TO BE CONTROLLED WITHIN LIMITS AS SHOWN MACHINING TOLERANCE ± 0.25 M.M. UNLESS OTHERWISE SHOWN NON-MACHINING TOLERANCE ±	CARD CODE	DRAWING NO. 4-7-0111-13-01570	REV. 00
	SHEET NO	NO. OF SHEETS	

FIRST ANGLE PROJECTION (ALL DIMENSIONS IN MILLIMETRES)

05-249/B

CAUTION THE INFORMATION ON THIS DOCUMENT IS THE PROPERTY OF BHARAT HEAVY ELECTRICALS LTD. IT MUST NOT BE USED DIRECTLY OR INDIRECTLY IN ANY WAY DETRIMENTAL TO THE INTEREST OF THE COMPANY.

REV.	DATE	ALTERED
01		CHECKED
ZONE		

2

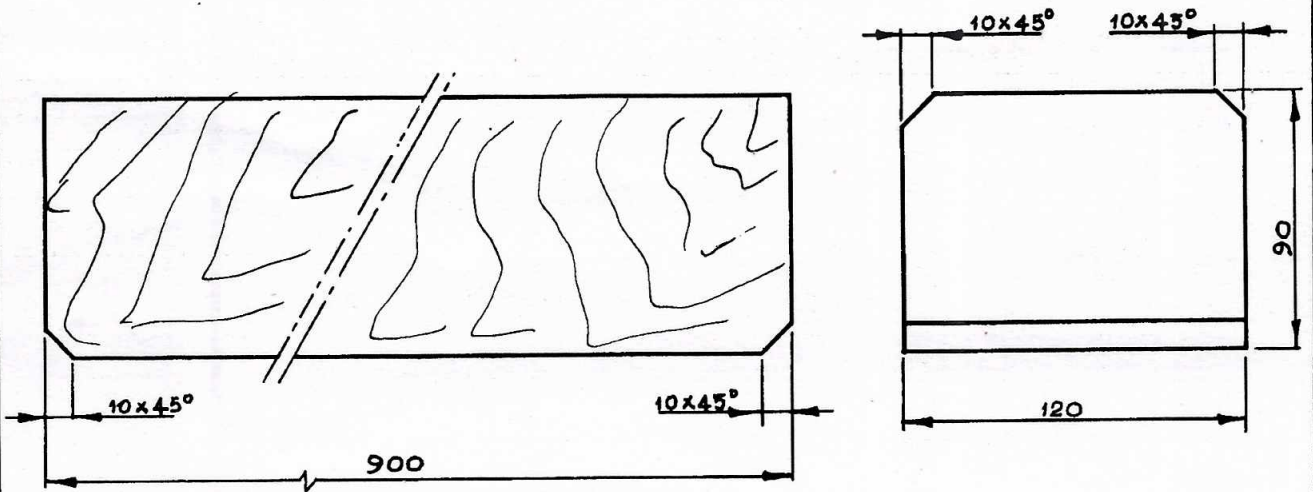

		HARD WOOD	
		KONGOO (OR) EQUI.	
ITEM NO.	DESCRIPTION	MATL. CODE	UNIT WT.
		MATL. SPEC	QTY.

EQPT: DRAW BENCH 800 KN/315 KN.



Bharat Heavy Electricals Ltd.,
SEAMLESS STEEL TUBE PLANT
TIRUCHIRAPALLI-620 014

DRN	NAME	SIGN	DATE
CHR	RUBAN.H.	<i>[Signature]</i>	29-05-87.
APPD.	A. ARACKIAM	<i>[Signature]</i>	5-8-87.
			14-10-77

DEPT.	GRADE OF UNTOLED. DIM. C/M/F		SCALE	WEIGHT (KG)	REF. TO ASSY./OLD DRG.	ITEM NO.
CODE			1:2,5			

TITLE	CARD CODE	DRAWING NO.	REV.
WOOD FOR COLLECTING TROUGH. BOTTOM PIECE	U 01	4-7-0111-13-03450	00

CAUTION THE INFORMATION ON THIS DOCUMENT IS THE PROPERTY OF BHARAT HEAVY ELECTRICALS LTD. IT MUST NOT BE USED DIRECTLY OR INDIRECTLY IN ANY WAY DETRIMENTAL TO THE INTEREST OF THE COMPANY.

FIRST ANGLE PROJECTION (ALL DIMENSIONS IN MILLIMETRES)

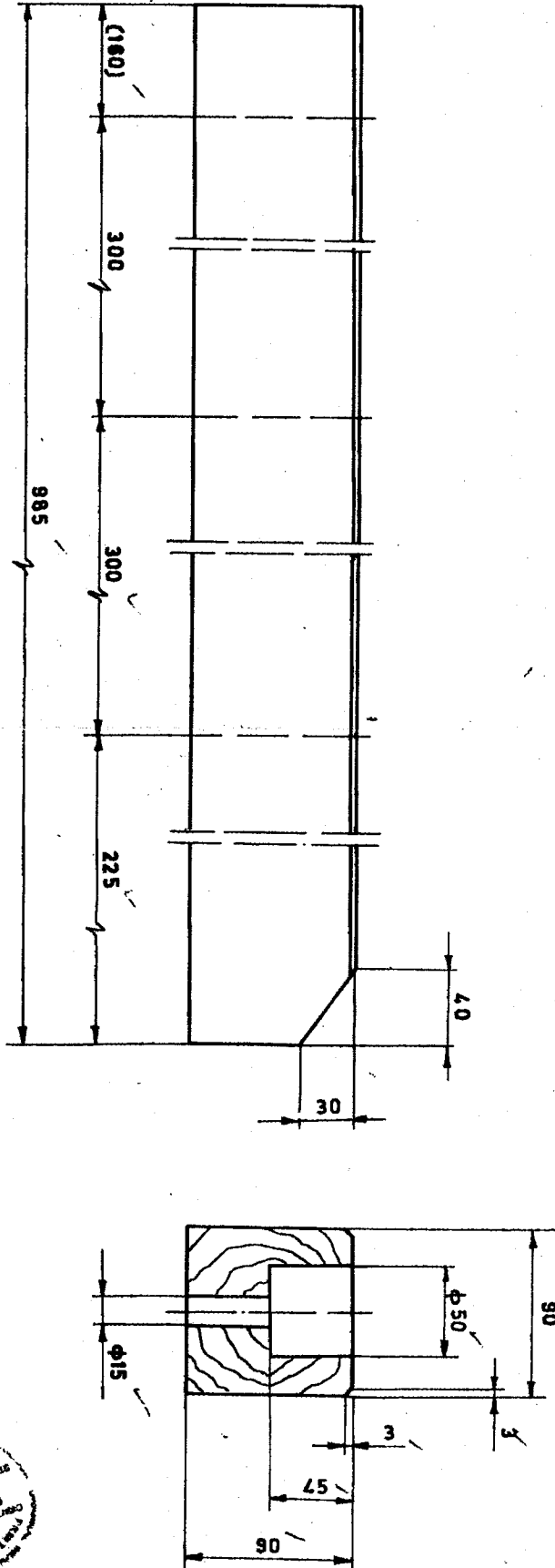

REV	DATE	ALTERED
01		CHECKED
ZONE		

<p>Bharat Heavy Electricals Ltd., SEAMLESS STEEL TUBE PLANT TIRUCHIRAPPALLI-620 014</p>		<p>Hardwood (for Jerru)</p>	
DEPT	GRADE OF WOOD	SCALE	WEIGHT (kg)
	C/M/F	1:25	5,3
<p>EAPT: PUSH POINTING PRESS PAT 63/160/R.S.</p>		REF TO ASSY/DWG NO	DATE
		0 301 188-14-221	11.6.80
ITEM NO.	DESCRIPTION	DRAWING NO.	UNIT WT
<p>WOOD LINER</p>		CARD CODE	DRAWING NO.
		U 01	3-7.0103-11-01090
REV	DATE	ALTERED	ITEM NO.
01		CHECKED	
ZONE			

CAUTION THE INFORMATION ON THIS DOCUMENT IS THE PROPERTY OF BHARAT HEAVY ELECTRICALS LTD. IT MUST NOT BE USED DIRECTLY OR INDIRECTLY IN ANY WAY DETRIMENTAL TO THE INTEREST OF THE COMPANY.

FIRST ANGLE PROJECTION (ALL DIMENSIONS IN MILLIMETRES)

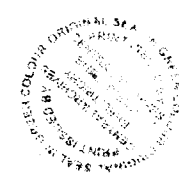
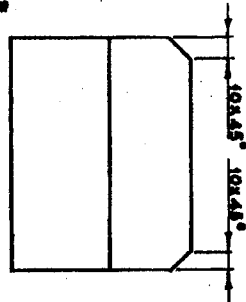
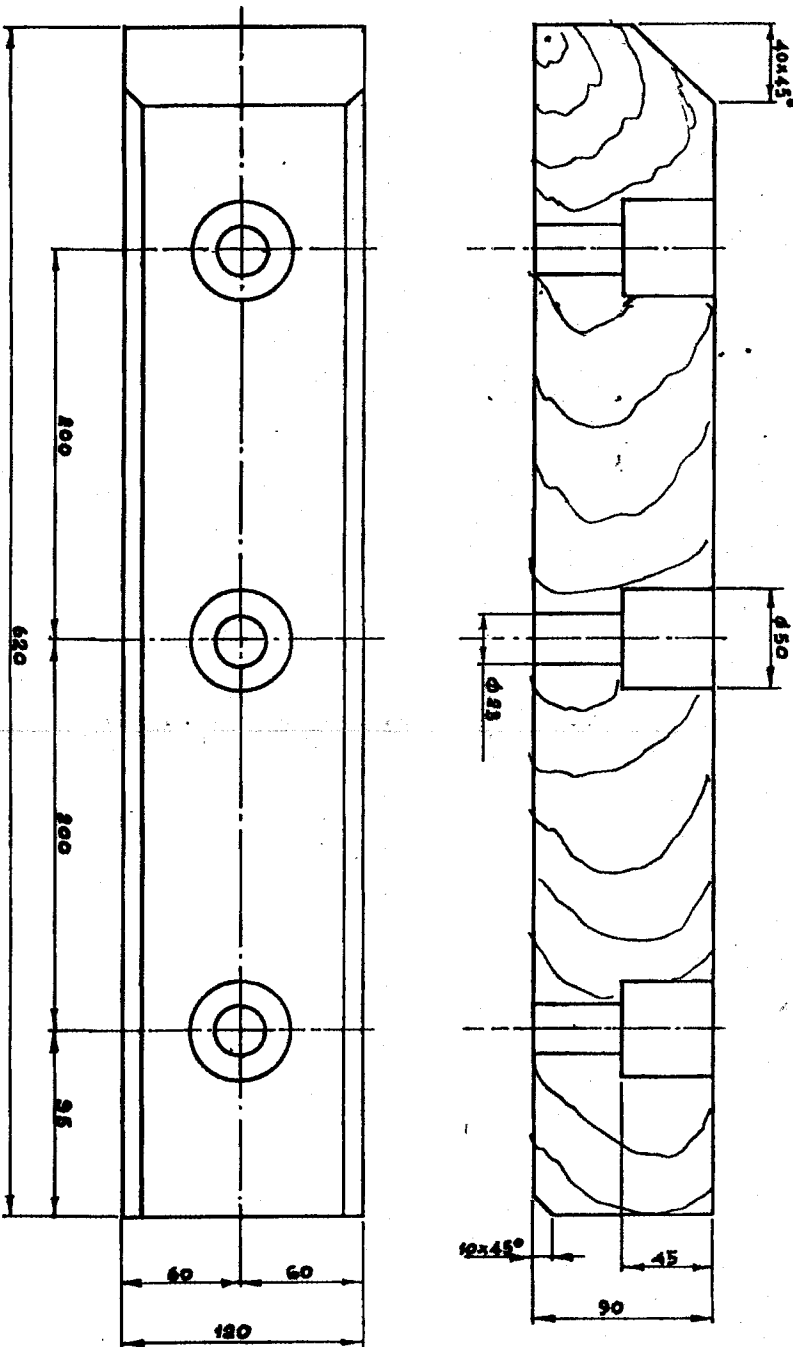

REV	DATE	ALTERED	CHECKED
01			
ZONE			

<p>Bharat Heavy Electricals Ltd., SEAMLESS STEEL TUBE PLANT TIRUCHIRAPPALLI - 620 014</p>		<p>HARD WOOD Kando (AK) / EAVI</p>	
<p>DEPT: DRAW BENCH 800 KM/315 KM.</p>		<p>DESCRIPTION:</p>	
ITEM NO.	DESCRIPTION	DRAWING NO.	UNIT WT
<p>GRADE OF UNPRO. DIM C.M.F.</p>		<p>MATL. SPEC</p>	
CODE	SCALE	APPD	QTY
	1:2.5		
<p>NAME</p>		<p>DATE</p>	
<p>RUBAN, N</p>		<p>22/5/88</p>	
<p>SIGN</p>		<p>NO. OF ITEMS</p>	
<p>[Signature]</p>		<p>1</p>	
<p>WEIGHT (kg)</p>		<p>REF TO ASD/OLD DRG</p>	
<p>11.93</p>		<p></p>	
<p>TITLE</p>		<p>DRAWING NO</p>	
<p>WOOD FOR COLLECTING TROUGH. RIGHT PIECE</p>		<p>3-7-011-13-02663.</p>	
<p>CARD CODE</p>		<p>REV</p>	
<p>U 01</p>		<p>00</p>	