

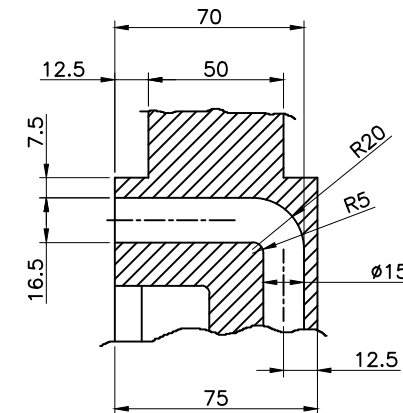

SECTION- 'AA'

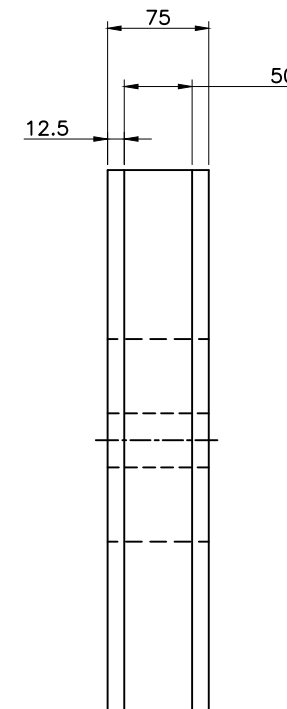
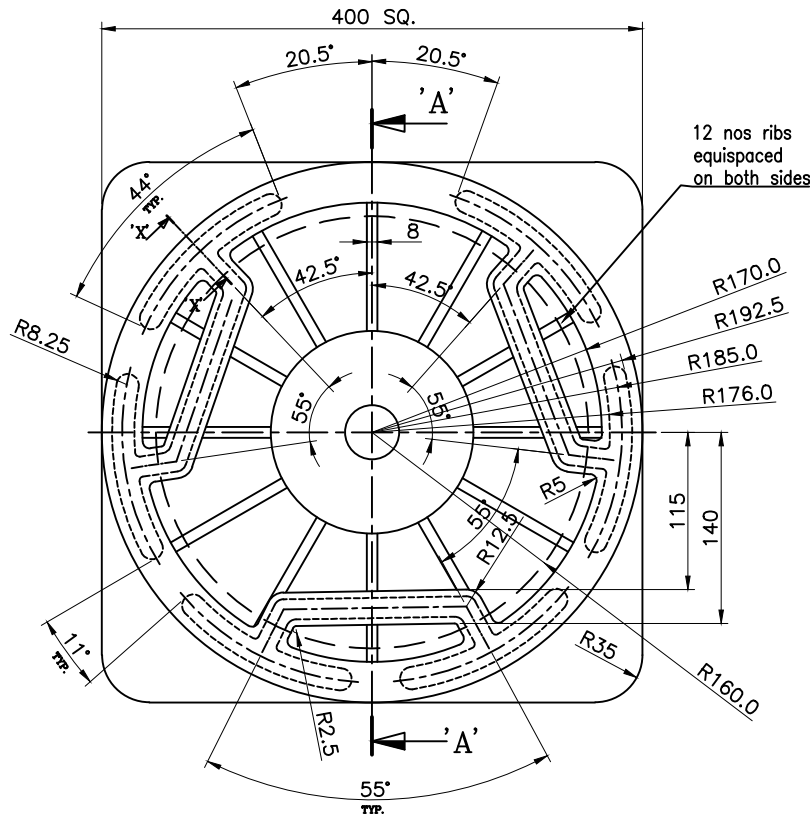

SECTION- 'XX'

Technical Requirements:

1. Aluminium Alloy AlSi10Mg-T6 as per DIN (LM-9) grade material to be used for making the Casting.
2. The Six (6) hollow segments in the frame are to be matched with those on the End Covers. Refer the drawing attached.
3. The Casting has to be supplied in Rough machined as required to maintain dimensions.
4. Dye Penetrant test should be conducted on rough machined surfaces such as end faces and corners of the joining segments.
5. Casting to be sand blasted for removing any projections and unwanted deposits.
6. Suitable primer to be applied on the casting.
7. Approximate weight of the casting will be 20 kgs (for indicative only).

TYPE OF PRODUCT OR NAME OF CUSTOMER/PROJECT		PMSM -150			
 BHARAT HEAVY ELECTRICALS LIMITED Corp. R&D Division, Vikasnagar HYDERABAD - 500 093		NAME	SIGN.	DATE	NO.OF VAR.
		DRN.	GVN		
		CHD.	GVN		
APPD.	SKR				
DEPT.	 SCALE WEIGHT(Kg) REF. TO ASSY DRG. ITEM NO. NO.OF ITEMS				
CODE					
TITLE		End Cover Casting (DE) (Unmachined)		DRAWING NO. 2DC157050008	
				REV. 00	
				SHEET NO. NO OF SHEETS	

REV.	DATE	ALTERED	APPD.	REV.	DATE	ALTERED	APPD.	REV.	DATE	ALTERED	APPD.	REV.	DATE	ALTERED	APPD.
ZONE		CHECKED		ZONE		CHECKED		ZONE		CHECKED		ZONE		CHECKED	
1				2				3				4			
5				6				7				8			

THE INFORMATION ON THIS DOCUMENT IS THE PROPERTY OF BHARAT HEAVY ELECTRICALS LIMITED. IT MUST NOT BE USED DIRECTLY OR INDIRECTLY IN ANY WAY DETRIMENTAL TO THE INTEREST OF THE COMPANY.