



**TECHNICAL SPECIFICATION FOR
HYDROGEN GENERATION PLANT
2 X 800 MW NTPC GADERWARA STPP STAGE-I**

SPEC NO.PE-TS-394-168-A001	
VOLUME-IIB	
SECTION	
REV.NO.0	DATE
SHEET	

CABLING, EARTHING & LIGHTNING PROTECTION

CABLING, EARTHING & LIGHTNING PROTECTION	
1.00.00	CODES AND STANDARDS:
1.01.00	<p>All standards, specifications and codes of practice referred to herein shall be the latest editions including all applicable official amendments and revisions. In case of conflict between this specification and those (IS codes, standards, etc.) referred to herein, the former shall prevail. All work shall be carried out as per the following standards/ codes as applicable.</p> <p>IS:2309, IEEE:142, IEEE-80, IS:1255, IS:3043, DIN 46235.</p>
2.00.00	REQUIREMENTS
2.01.00	<p>The complete cable support system shall be supplied and installed for the entire work is in the bidder's scope. The system shall enable proper laying of all power, control, instrumentation and telephone cables, and shall provide necessary mechanical protection, ventilation and segregation for them as per latest engineering practices and cable manufacturers' recommendation .The cable installation shall be carried out as per IS:1255. All hardware and anchoring arrangement shall be included. All steel members shall be hot dip galvanized. Cable shall be terminated using double compression type cable glands. Cable lugs for power cables shall be tinned copper solderless crimping type conforming to DIN 46235 suitable for aluminum compacted conductor cables.</p>



**TECHNICAL SPECIFICATION FOR
HYDROGEN GENERATION PLANT
2 X 800 MW NTPC GADERWARA STPP STAGE-I**

SPEC NO.PE-TS-394-168-A001

VOLUME-IIB

SECTION

REV.NO.0

DATE

SHEET

LT SWITCHGEAR

CLAUSE NO.	TECHNICAL REQUIREMENTS										
	LT SWITCHGEAR										
1.00.00	CODES AND STANDARDS										
1.01.00	<p>All standards, specifications and codes of practice referred to herein shall be the latest editions including all applicable official amendments and revisions. In case of conflict between this specification and those (IS codes, standards, etc.) referred to herein, the former shall prevail. All work shall be carried out as per the following standards/ codes as applicable.</p> <p>IEC: 60947, IS: 13947, IEC: 60439, IS: 8623, IEC: 61850</p>										
2.00.00	<p>TYPE</p> <table border="0" style="width: 100%;"> <tr> <td style="width: 50%;">Circuit Breakers</td> <td style="width: 50%;">Shall be air break, three pole, spring charged, and horizontal drawout type, suitable for electrical operation.</td> </tr> <tr> <td>Switchgear</td> <td>Fully drawout type Single Front</td> </tr> <tr> <td>MCC</td> <td>Fully drawout type Double Front.</td> </tr> <tr> <td>ACDB / DCDB</td> <td>Fixed type Double Front</td> </tr> </table>			Circuit Breakers	Shall be air break, three pole, spring charged, and horizontal drawout type, suitable for electrical operation.	Switchgear	Fully drawout type Single Front	MCC	Fully drawout type Double Front.	ACDB / DCDB	Fixed type Double Front
Circuit Breakers	Shall be air break, three pole, spring charged, and horizontal drawout type, suitable for electrical operation.										
Switchgear	Fully drawout type Single Front										
MCC	Fully drawout type Double Front.										
ACDB / DCDB	Fixed type Double Front										
3.00.00	<p>SYSTEM PARAMETERS</p> <p>415VAC +/- 10 %(SOLIDLY GROUNDED)</p> <p>50 Hz +3%/-5%</p> <p>Fault Level: 45kA RMS for 1sec (105 KA PEAK)</p> <p>240 V DC nominal (187V DC -242V DC) isolated type</p>										
4.00.00	<p>TEMPERATURE RISE</p> <p>The temperature rise of the horizontal and vertical busbars and main bus link including all power draw out contacts when carrying 90% of the rated current along the full run shall in no case exceed 55 deg. C with silver plated joints and 40 deg. C with all other types of joints over an ambient of 50 deg C. The temperature rise of the accessible parts / external enclosures expected to be touched in normal operation shall not exceed 20 deg. C. The temperature rise of manual operating means shall not exceed 10 deg. C for metallic & 15 deg. C for insulating material. Temperature rise for the busbars shall be carried out at 90% of the rated current. The above temperature rise limits are applicable for busducts also without any current derating.</p>										

CLAUSE NO.	TECHNICAL REQUIREMENTS		
5.00.00	OPERATIONAL REQUIREMENTS		
5.01.00	Breakers		
5.01.01	Breakers shall have anti-pumping feature.		
5.01.02	The incomer and bus coupler breakers for switchgear shall be electrically operated with Numerical communicable relays.		
5.01.03	Breakers shall have inherent fault making and breaking capacities. They shall have shunt trip coils. All breakers shall have built in interlocks for equipment and personnel safety.		
5.01.04	Paralleling of two supplies shall be avoided by interlocking except for switchgear where auto-changeover is provided. Breaker contact multiplication, if required, shall be through latch relay.		
5.01.05	Mechanical tripping shall be through red 'Trip' push button outside the panels for breakers, and through control switches for other circuits.		
5.01.06	Provision of mechanical closing of breaker only in 'Test' and 'Withdrawn' position shall be made. Alternatively, mechanical closing facility should be normally inaccessible, accessibility rendered only after deliberate removal of shrouds. It shall be possible to close the door with breaker in test position.		
5.01.07	Clear status indication for each circuit shall be provided through lamps, switch positions or other mechanical means.		
5.02.00	Switches, Contactors and Fuses		
5.02.01	Incomers for MCCs and DBs rated below 250A shall be load break isolators.		
5.02.02	Motor starter contactors shall be of air break, electromagnetic type suitable for DOL starting of motor, and shall be of utilization category AC-3 for ordinary and AC-4 for reversing starters. For conveyor motors, minimum rating of power contactors shall be 200% of the full load current of the motors. For other motors minimum rating of power contactors shall be 160% of full load current of motor. DC contactor shall be of DC-3 utilization category.		
5.02.03	Fuses shall be HRC type with operation indicator. Isolating switches shall be of AC-23A category when used in motor circuit, and AC-22A category for other applications. Fuse switch combination shall be provided wherever possible.		
5.02.04	The 250A & above feeders up to 630A shall have MCCB. MCCB shall be provided with Microprocessor based inbuilt front adjustable releases (overload & short circuit)		

CLAUSE NO.	<p style="text-align: center;">TECHNICAL REQUIREMENTS</p> 		
	<p>and shall have adjustable earth fault protection unit also. MCCB shall have current limiting feature. ON and OFF position of the operating handle of MCCB shall be displayed and the rotary operating handle shall be mounted on the door of the compartment housing MCCB. The compartment door shall be interlocked mechanically with the MCCB, such that the door can not be opened unless the MCCB is in OFF position. MCCB shall be provided with padlocking facility to enable the operating mechanism to be padlocked.</p>		
5.03.00	Panels		
5.03.01	All switchgears, MCCs, DBs, panels, modules, local starters and push buttons shall have prominent engraved identification plates.		
5.03.02	Local push button stations shall have metal enclosure of die cast aluminium or rolled sheet steel of 1.6mm thickness & shall be of DOP IP55. The DOP shall be IP-65 in case the same are located in dusty areas. Push buttons shall be of latch type with mushroom knobs.		
5.03.03	Where breaker / starter module front serves as compartment cover, suitable blanking covers, one for each size of modules per switchboard shall be supplied for use when carriage is withdrawn.		
5.03.04	All non-current carrying metal work of boards / panels shall be effectively bonded to earth bus of galvanized steel, extending throughout the switchboard / MCC / DB. Positive earthing shall be maintained for all positions of chassis and breaker frame.		
5.03.05	Suitable trolley arrangement shall be provided for breaker / starter modules. Two trolleys per switchgear room shall be provided so that top most breaker module of all types, sizes and rating can be withdrawn on trolley and lowered for maintenance purpose.		
5.03.06	It should be possible to carryout maintenance on a feeder with adjacent feeders alive.		
5.03.07	<p>DC fuse board shall consist of:</p> <ul style="list-style-type: none"> -1 no.63A switch as incomer with meters, lamps and auxiliary contactors. -8 nos. outgoing feeders with 16A HRC fuses. 		
5.03.08	<p>AC fuse board shall consist of:</p> <ul style="list-style-type: none"> -1 no 63A TPN SFU as incomer with lamps and meters. -9 nos.16A SPN SFU & 3 nos.16A TPN SFU as outgoing. 		

CLAUSE NO.	TECHNICAL REQUIREMENTS	
5.04.00	Control, Protection & Metering Requirements	
5.04.01	Control circuits shall operate at suitable voltage of 110V AC or 240V DC / 120V DC. Necessary control supply transformers having primary and secondary fuses shall be provided for each MCC, 2 x 100% per bus section. However the breakers shall operate on 240V DC. The auxiliary bus bars for control supply shall be segregated from main bus bars. The control supplies shall be monitored.	
5.04.02	Contractor shall fully co-ordinate overload and short circuit tripping of breaker with upstream and down stream breakers / fuses / MCCBs / motor starters. Various equipments shall meet requirement of Type-II class of coordination as per IEC.	
5.04.03	The protective relays shall be communicable numerical relays. These numerical relays shall be of types as proven for the application and shall be subject to Employer's approval. Numerical relays shall have appropriate setting ranges, accuracy, resetting ratio and other characteristics to provide required sensitivity. All equipments shall have necessary protections as detailed in the standard scheme drawings.	
5.04.04	<p>All equipments shall have necessary protections. However, following minimum protections shall be provided:</p> <ol style="list-style-type: none"> 1) Contactor controlled motor feeders (Motors below 110 kW) <ol style="list-style-type: none"> a) Instantaneous short circuit protection on all phases through HRC cartridge type fuses rated for 80 kA rms (prospective breaking capacity at 415V). b) Thermal overload protection c) Single phasing protection for motors protected by fuses 2) Incomers / bus coupler / outgoing breaker feeders other than motor feeders. <ol style="list-style-type: none"> a) Three phase Overcurrent protection (50) b) Three phase earth fault protection (50N3) c) Restricted earth fault protection for transformer incomers (64R) 3) Breaker controlled motor feeders(Motors 110KW & above) <ol style="list-style-type: none"> a) Thermal Overload Protection (50I) 	

CLAUSE NO.	TECHNICAL REQUIREMENTS		
	<ul style="list-style-type: none"> b) Three phase Short Circuit Protection (50) c) Earth Fault Protection (50N/50N2) d) Thermal Overload Alarm (50A) 		
5.05.00	General requirements of Numerical Relays		
5.05.01	All relays and timers shall be rated for control supply voltage as mentioned elsewhere under parameters and shall be capable of satisfactory continuous operation between 70-120% of the rated voltage. Making, carrying and breaking current ratings of their contacts shall be adequate for the circuits in which they are used. Interrogation voltage for the binary inputs shall be suitably selected to ensure avoidance of mal-operation due to stray voltages.		
5.05.02	All Numerical relays shall have communications on two ports, local front port for communication to laptop and a second port on IEC 61850 to communicate with owner's data concentrator through LAN.		
5.05.03	All Numerical Relays shall have features for electrical measurement including voltage, current, power (active / reactive) and energy parameters.		
5.05.04	All Numerical Relay shall have key pad / keys to allow relay settings from relay front. All hand reset relays shall have reset button on the relay front. Relay to be self or hand reset shall be software selectable. Manual resetting shall be possible from remote.		
5.05.05	The protective relays shall have at least 10 Nos. programmable potential free contacts. Programmable Auxiliary relays shall have contacts as required.		
5.05.06	For control from DDCMIS, 24V DC signal shall be provided from DDCMIS to the numerical relays. Preferably, no separate coupling relays shall be provided.		
5.05.07	Trip circuit supervision shall be provided for all feeders to monitor the circuit breaker trip circuit both in pre trip and post trip conditions.		
5.05.08	Schematics requiring auxiliary relays / timers for protection function shall be a part of Numerical Relay. The number of auxiliary relay and timer function for protection function shall be as required by the scheme. Auxiliary relays for interlocking purpose shall be of self reset type.		
5.05.09	The numerical processor shall be capable of measuring and storing values of a wide range of quantities, all events, faults and disturbance recordings with a time		

CLAUSE NO.	TECHNICAL REQUIREMENTS	
	<p>stamping using the internal real time clock. Battery back up for real time clock in the event of power supply failure shall be provided.</p>	
5.05.10	<p>Sequence of events shall have 1ms resolution at device level.</p>	
5.05.11	<p>Ethernet switches shall be “substation hardened” and shall comply to IEC61850-3 for communications and environment requirements. The Ethernet switches shall be of managed type with four (4) numbers Single-mode Fibre Optic cable ports and required number of Copper ports to achieve the owners’ LAN configuration. One (1) no. of Ethernet switch per switch board shall be provided & these switches shall be mounted inside the switchgear Panels.</p>	
5.05.12	<p>In case of remote controlled breaker panels, following shall be ensured.</p> <p>The circuit breaker will normally be controlled from remote control panels (employer’s DDCMIS) through closing and shunt trip coils. The Local control console of the relay flush mounted on the switchgear would normally be used only for testing of circuit breaker in isolated position, and for tripping it in an emergency. Provision for closing & tripping of the circuit breaker locally from laptop through serial port shall be possible to facilitate commissioning activities. The basic control scheme of breaker feeders shall be developed as per the schematic logics in the relay. The schematics shall be developed in soft inside the relay. Numerical relays shall be interfaced with employer’s DDCMIS through 24V DC signal for closing / opening operations.</p>	
5.05.13	<p>Hardwired contacts from the relay shall be wired to PLC / DCS system as per requirements. The numerical relay shall be capable of measuring and storing values of a wide range of quantities, events, faults and disturbance recordings.</p>	
5.05.14	<p>The alarm / status of each of protection function and trip operation shall be communicated to PLC / DCS. The numerical relays shall have built in feature / hardware interface to provide such inputs to PLC / DCS for analog / digital values.</p>	
5.05.15	<p>It shall be possible to carryout open / close operation of breakers from a laptop by interfacing through the relay front port during initial commissioning.</p>	
5.06.00	<p>Meters / instruments</p> <p>All meters / instrument shall be flush mounted on front panel, at least 96 sq.mm. size with 90 degree linear scales and accuracy class of 2.0 or better.</p>	
5.06.01	<p>All motors of 30kW and above upto 100kW shall have an digital Energy Meter with analog current output. Each bus-section shall have bus VT, voltmeter with selector switch, and other relay and timers required for protection. Adequate control and selector switches, push buttons and indicating lamps shall be provided. Thermostatically controlled space heaters with switches shall be provided to prevent condensation.</p>	

CLAUSE NO.	TECHNICAL REQUIREMENTS		
5.07.00	<p>Control from Remote</p> <p>Necessary hardware shall be provided in the switchgear panel like coupling relays (if required) of 24V DC with max. burden of 2.5VA, auxiliary relays, current / voltage transducers (4-20mA, dual output) etc. to effect interlocks, exchange information / status and exercise control from remote.</p>		
6.00.00	<p>DESIGN AND CONSTRUCTIONAL FEATURES</p>		
6.01.00	<p>All 415V switch gear motor control centers (MCCs), AC & DC distribution boards (DB s), etc shall have two incomers and one bus-coupler arrangement with following features:</p> <ol style="list-style-type: none"> 1) Shall be of metal enclosed, indoor, floor mounted and free standing type. 2) All frames and load bearing members shall be fabricated using mild steel structural sections or pressed and shaped cold rolled sheet steel of thickness not less than 2mm. 3) Frame shall be enclosed in cold rolled sheet steel of thickness not less than 1.6mm. Doors and covers shall also be of cold rolled sheet steel of thickness not less than 1.6 mm. Stiffeners shall be provided wherever necessary. Removable gland plates of thickness 3mm (hot/cold rolled sheet steel) or 4 mm (non-magnetic material) shall be provided for all panels. 4) All switchboards / panels shall be of dust and vermin proof. All cutouts shall have EPDM / Neoprene gaskets. 5) All switchboards, MCCs and DB s shall have following distinct vertical sections. <ol style="list-style-type: none"> a) Completely enclosed bus bar compartment for horizontal and vertical bus bars. b) Completely enclosed switchgear compartments (one for each circuit housing circuit breakers, motor starter or switch-fuse feeder). c) Compartment for cable alley or cable box for power and control cables. Cable terminations located in cable alley shall be designed to meet the Form IVb Type 7 (as per IEC 60439) for safety purpose. The termination for each module shall have its own integral glanding facility. 		

CLAUSE NO.	TECHNICAL REQUIREMENTS 		
	<p>In case of cable boxes provided in distribution boards, they shall be segregated with complete shrouding for individual feeders at the rear for direct termination of cables.</p> <p>d) For cable connection to circuit breaker, a separately enclosed cable compartment shall also be acceptable.</p> <p>e) Compartment for relays and other control devices associated with a circuit breaker, wherever necessary.</p> <p>f) The switchboards / MCC / DBs of 1600A & above rating shall be of DOP IP42 & of IP52 for less than 1600A rating.</p> <p>g) All 415V switchgears, MCCs, AC & DC distribution boards etc. shall be painted by powder coating process. Paint shade for complete panels excluding end covers shall be RAL9002 & RAL5012 for extreme end covers of all boards.</p> <p>h) All draw out modules shall have distinct service, test and isolated positions with provision of external pad locking facility in each position. Power contacts shall get disconnected in both test and isolated positions whereas the control contacts shall get disconnected in isolated position only.</p> <p>6) Busbars shall be of high conductivity aluminium alloy or copper.</p> <p>7) The cross section of the horizontal bus bars shall be uniform through out the length of the switchboard and both horizontal as well as vertical bus bars shall be adequately supported and braced to withstand the stresses due to the specified short circuit currents. Neutral bus bar short circuit strength shall be same as the main bus bars.</p> <p>8) Minimum air clearance in air between phases and phase-earth shall be 25 mm for busbars and cable terminations. For all other components, the Clearances shall be at least 10mm. Wherever above is not possible except for horizontal and vertical busbars, insulation shall be provided by anti tracking sleeving or barriers. However for horizontal and vertical busbars, clearances specified above shall be maintained even when busbars are insulated / sleeved. Entire busbar system shall be insulated with PVC sleeves.</p>		

CLAUSE NO.	TECHNICAL REQUIREMENTS													
	<p>9) Busbar insulators shall be of track-resistant high strength non-hygroscopic, non-combustible type and suitable to withstand stresses due to over-voltages and short circuit current. Insulators and barrier of inflammable material such as Hylam shall not be accepted.</p> <p>10) All types of relays and timer shall be subject to Employer's approval. They shall be flush mounted with connections from inside, and shall have transparent & dust tight cover, removable from front, drawout construction for easy replacement and testing facility. The auxiliary relays and timer may be provided in fixed cases.</p> <p>11) Terminal Blocks Terminal blocks shall be 650V grade, 10Amps rated, made up of unbreakable polyamide 6.6 grade. The terminals shall be either screw type or screw-less (spring loaded) / cage clamp type with lugs. Marking on terminal strips shall correspond to the terminal numbering in wiring diagrams. All metal parts shall be of non-ferrous material. In case of screw type terminals the screw shall be captive, preferably with screw locking design. Maxi terminal / cage clamp type terminal blocks shall be provided for signals to be interfaced with DDCMIS / PLC.</p> <p>12) The switchgears/MCC shall be designed to offer adequate level of safety to operating/ maintenance personnel. Means shall be provided to prevent access to the live part to avoid accidents during service as well as maintenance period. Bidder shall bring out the safety means provided to achieve above. A detailed instruction plate suitable for wall mounting shall be provided for each switchgear/MCC room describing various safe operating procedure/safety precautions for safe operation and maintenance of switchgear/MCC.</p> <p>13) All current and voltage transformers as required for metering & protection specified shall be completely encapsulated cast resin insulated type. Incomers from transformers shall have CTs for transformer REF protection. The accuracy shall be as follows:</p> <table border="1" data-bbox="389 1449 1153 1690"> <thead> <tr> <th></th> <th>CTs</th> <th>PTs</th> </tr> </thead> <tbody> <tr> <td>Protection</td> <td>5P20,5VA</td> <td>3P</td> </tr> <tr> <td>Metering</td> <td>1.0</td> <td>0.5</td> </tr> <tr> <td>REF</td> <td>PS</td> <td></td> </tr> </tbody> </table>		CTs	PTs	Protection	5P20,5VA	3P	Metering	1.0	0.5	REF	PS		
	CTs	PTs												
Protection	5P20,5VA	3P												
Metering	1.0	0.5												
REF	PS													

CLAUSE NO.	<p style="text-align: center;">TECHNICAL REQUIREMENTS</p> 		
6.02.00	Indicating lamps shall be cluster LED type. All overload relays shall have overload reset push button.		
6.03.00	Switchgear / MCC shall have bottom cable entry.		
6.04.00	Contractor shall provide minimum one spare feeder for each type and rating of the outgoing feeders on each MCC / Switchgear.		
7.00.00	TYPE TESTS		
7.01.00	<p>GENERAL</p> <p>(a.) All equipments to be supplied shall be of type tested design. The Contractor shall submit for Owner's approval the reports of all the type tests as listed in this specification and carried out within last ten years from the date of bid opening. These reports should be for the tests conducted on the equipment similar to those proposed to be supplied under this contract and the test(s) should have been either conducted at an independent laboratory or should have been witnessed by a client.</p> <p>(b.) In case the Contractor is not able to submit report of the type test(s) conducted within last ten years from the date of bid opening, or in case the type test report(s) are not found to be meeting the specification requirements, the Contractor shall conduct all such tests under this contract at no additional cost either at third party lab or in presence of client/owner's representative and submit the reports for approval.</p> <p>(c.) All acceptance and routine tests as per the specification and relevant standards shall be carried out. Charges for these shall be deemed to be included in the equipment price.</p> <p>(d.) The type test reports once approved for any projects shall be treated as reference. For subsequent projects of NTPC, an endorsement sheet will be furnished by the manufacturer confirming similarity and "No design Change". Minor changes if any shall be highlighted on the endorsement sheet.</p>		
7.03.00	<p>L. T. SWITCHGEAR</p> <p>The following type test certificates on each type & rating of L.T. Switchgear and MCC panel shall be submitted.</p> <p>(a.) Short time withstand test.</p> <p>(b.) Temperature rise test.</p>		

CLAUSE NO.	TECHNICAL REQUIREMENTS 		
	<p>(c.) Class II - Protection co-ordination test for any three ratings of MCC module as selected by employer</p> <p>(d.) Test sequence –1 & combined test sequence on each rating of circuit breaker mounted inside the panel.</p> <p>(e.) Degree of protection tests</p> <p>(f.) Type test certificates for Numerical relays.</p>		



**TECHNICAL SPECIFICATION FOR
HYDROGEN GENERATION PLANT
2 X 800 MW NTPC GADERWARA STPP STAGE-I**

SPEC NO.PE-TS-394-168-A001	
VOLUME-IIB	
SECTION	
REV.NO.0	DATE
SHEET	

**GENERAL TECHNICAL REQUIREMENT FOR
CONTROL & INSTRUMENTATION FOR HYDROGEN
GENERATION PLANT**

	2X800 MW GADARWARA STPP STAGE I	SECTION: C
	SPECIFIC TECHNICAL REQUIREMENTS (C&I) HYDROGEN GENERATION PLANT	

1.0 GENERAL TECHNICAL REQUIREMENTS (C&I)

1.0 The control of Hydrogen generation plant shall be through dual processor based PLC system. PLC unit shall be provided with two processors (main processing unit with memories), one for normal operation and one as Cold standby. The PLC system shall be provided with necessary interface hardware and software for dual fiber optic connectivity including LIU (Light Interface Unit) at PLC end and interconnection with DDCMIS located at main plant Control Room for monitoring of signal information. The communication protocol shall be OPC compliant. The dual fiber optic communication cable between bidders control panels and BHEL's DDCMIS shall be in bidder's scope. Bidder shall submit PLC system configuration drawing along with functional write-up along with the offer.

1.1 Two nos. OWS with 21" color TFT monitor along with keyboard & mouse shall be provided by the bidder for operation & monitoring of the entire H2 generation plant. It shall be possible to use the same OWS as programming station. Bidder to provide one number A4 size color laser printer. Complete PLC based control system with OWS, 1x100% UPS (30 Min back up) and 1x100% UPS battery (Ni-Cd) for H2 generation plant shall be in bidder's scope.

The PLC panel shall be of Schneider/ SIEMENS/ ROCKWELL AUTOMATION / ABB / GE FANUC/L&T make. The make of the printer shall be HP/ XEROX or equivalent. PC for OWS shall be of workstation grade and shall be of HP/DELL or equivalent make only.

1.2 PLC control system shall be time synchronized with Master clock system of the main plant through RS-485/IRIG-B link to ensure uniform time indication throughout the Plant. The required provision shall be made by the bidder at PLC end to achieve the same. The time format shall be finalised by BHEL during detail engineering.

1.3 The software and hardware for the offered PLC system shall be of latest version and shall be upgradable. Bidder to ensure availability of the spares and service support for the offered PLC system for minimum 10 years after guarantee period.

	2X800 MW GADARWARA STPP STAGE I	SECTION: C
	SPECIFIC TECHNICAL REQUIREMENTS (C&I) HYDROGEN GENERATION PLANT	
<p>1.4</p> <p>1.5</p> <p>1.6</p> <p>1.7</p> <p>1.8</p> <p>1.9</p>	<p>All necessary instruments such as transmitters/temperature elements/sensors/switches/gauges etc. shall be provided for safe, efficient, reliable operation and maintenance of the H₂ generation plant. All instrument devices shall be provided with explosion proof enclosure as described in NEC (USA) Article 500, Class-I, Div. I or provided with suitable type Zener barriers of standard approved make meeting the requirements as approved by the Chief Controller of Explosives, India and statutory authorities.</p> <p>The quantity of instruments shall be as per tender P&ID and Design Memorandum/Philosophy as a minimum, for bidding purpose. However, bidder shall also include in his proposal all the instruments and devices, which are needed for completeness of system/equipment, supplied by the bidder, even if the same is not specifically appearing in the P&ID and Design philosophy. During detail engineering, if any such additional instruments are required for safe & reliable operation of plant, bidder shall supply the same without any price implication.</p> <p>All the instrumentation equipments and accessories under this specification shall be furnished as per technical specification and ranges, makes/numbers as approved by the owner during detail engineering.</p> <p>The necessary root valves, impulse piping, drain cocks, gauge-zeroing cocks, valve manifolds and all the other accessories required for mounting/ erection of the local instruments shall be furnished, even if not specifically asked for, on as required basis. The instrument fittings shall be of forged SS. Instrument piping shall be designed for maximum design pressure & temperature of the process. Pressure instrument connection shall be ½" or 12 mm pipe connection. The contacts of equipment mounted instruments, sensors, switches etc. for external connection including spare contacts shall be wired out to the LCP.</p> <p>All electrical actuators shall be of integral starter type.</p> <p>Following documents to be furnished by the bidder along with the bid:</p> <ul style="list-style-type: none"> • PLC configuration diagram. • Duly stamped and signed copy of Quality Plans. • Requirement of electronic earthing, if any, for PLC based control system. 	

	2X800 MW GADARWARA STPP STAGE I	SECTION: C
	SPECIFIC TECHNICAL REQUIREMENTS (C&I) HYDROGEN GENERATION PLANT	

1.10 Drawings/Documents and data to be furnished after award of the contract:

- Input/Output signal list.
- BOM of PLC.
- Control panel/control desk/charger panel/battery GA drawings.
- Power distribution scheme.
- PLC control room layout drawing.
- PLC and field instruments quality plan.
- PLC data sheet.
- Cable schedule and cable interconnection drawing.
- Instrument Schedule.
- Instrument Data sheets.
- Any other document decided during detailed engineering.

1.11 Industrial grade furniture chairs (2 nos.), keypad (1 no.), Locker set (1 no.) etc. shall be in bidders scope. Revolving chairs with wheels and with provision for adjustments of height (hydraulically/gas lift) shall be provided for the operators in local Control Room area. Chair pedestal shall be made of 5mm thick MS plate covered with poly-propylene cladding. Arm-rests in one piece shall be of poly-urethane and twin wheel castor of glass filled nylon. The exact details shall be finalized & approved by owner/purchaser during detailed engineering.

All furniture shall be from reputed suppliers like Rittal / Godrej / Pyrotech or equivalent as approved by owner/purchaser.

This document is the property of NATIONAL THERMAL POWER CORPORATION LTD. No part of this document will be reproduced by any means without the written permission.

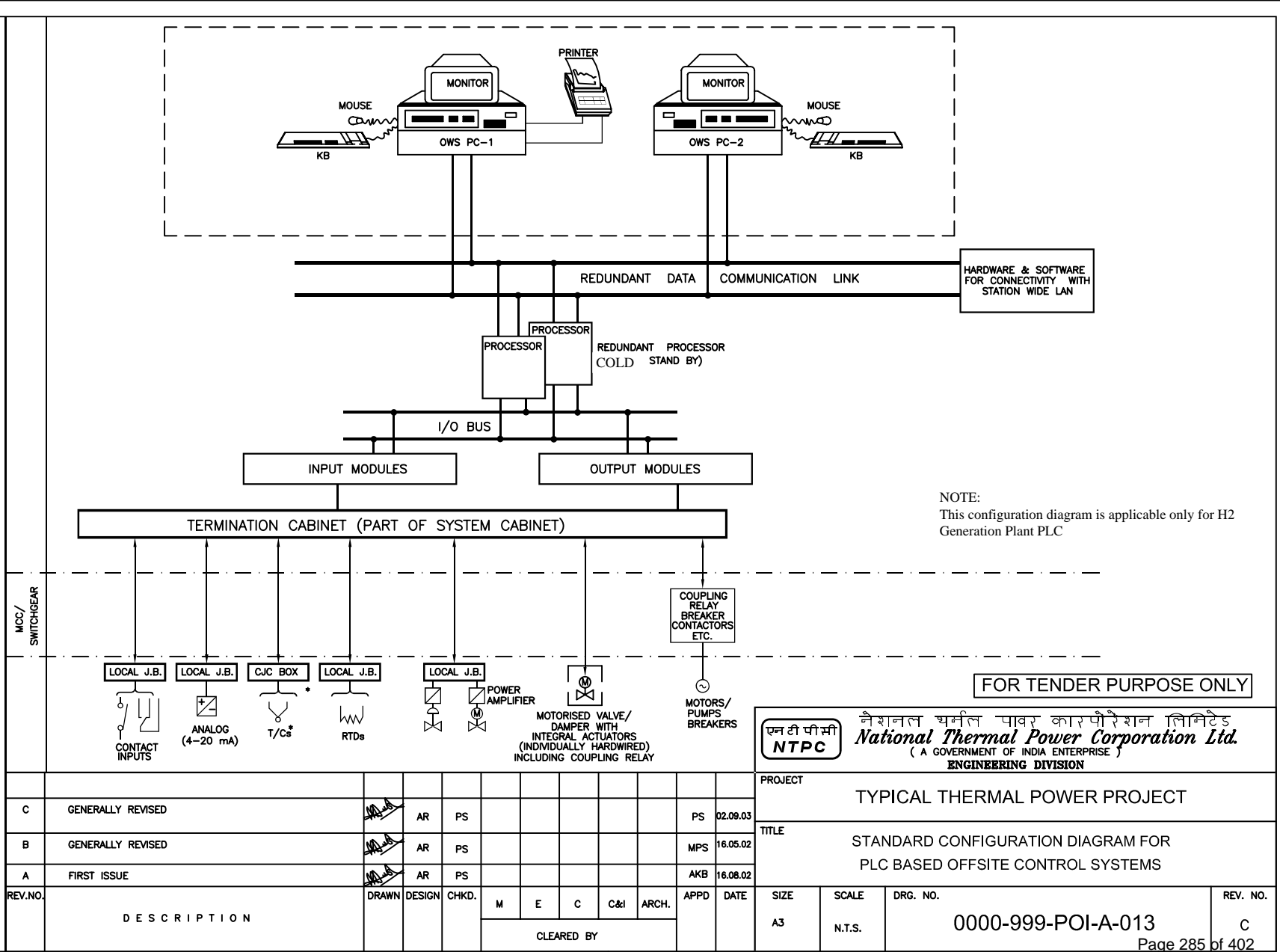

NOTE:
This configuration diagram is applicable only for H2 Generation Plant PLC

FOR TENDER PURPOSE ONLY

नैशनल थर्मल पावर कारपोरेशन लिमिटेड
National Thermal Power Corporation Ltd.
 (A GOVERNMENT OF INDIA ENTERPRISE)
ENGINEERING DIVISION

REV.NO.	DESCRIPTION	DRAWN	DESIGN	CHKD.	M	E	C	C&I	ARCH.	APPD	DATE
C	GENERALLY REVISED									PS	02.09.03
B	GENERALLY REVISED									MPS	16.05.02
A	FIRST ISSUE									AKB	16.08.02

PROJECT		TYPICAL THERMAL POWER PROJECT	
TITLE		STANDARD CONFIGURATION DIAGRAM FOR PLC BASED OFFSITE CONTROL SYSTEMS	
SIZE	SCALE	DRG. NO.	REV. NO.
A3	N.T.S.	0000-999-POI-A-013	C

STANDARD PLC CONFIGURATION DIAGRAM FOR HYDROGEN GENERATION PLANT

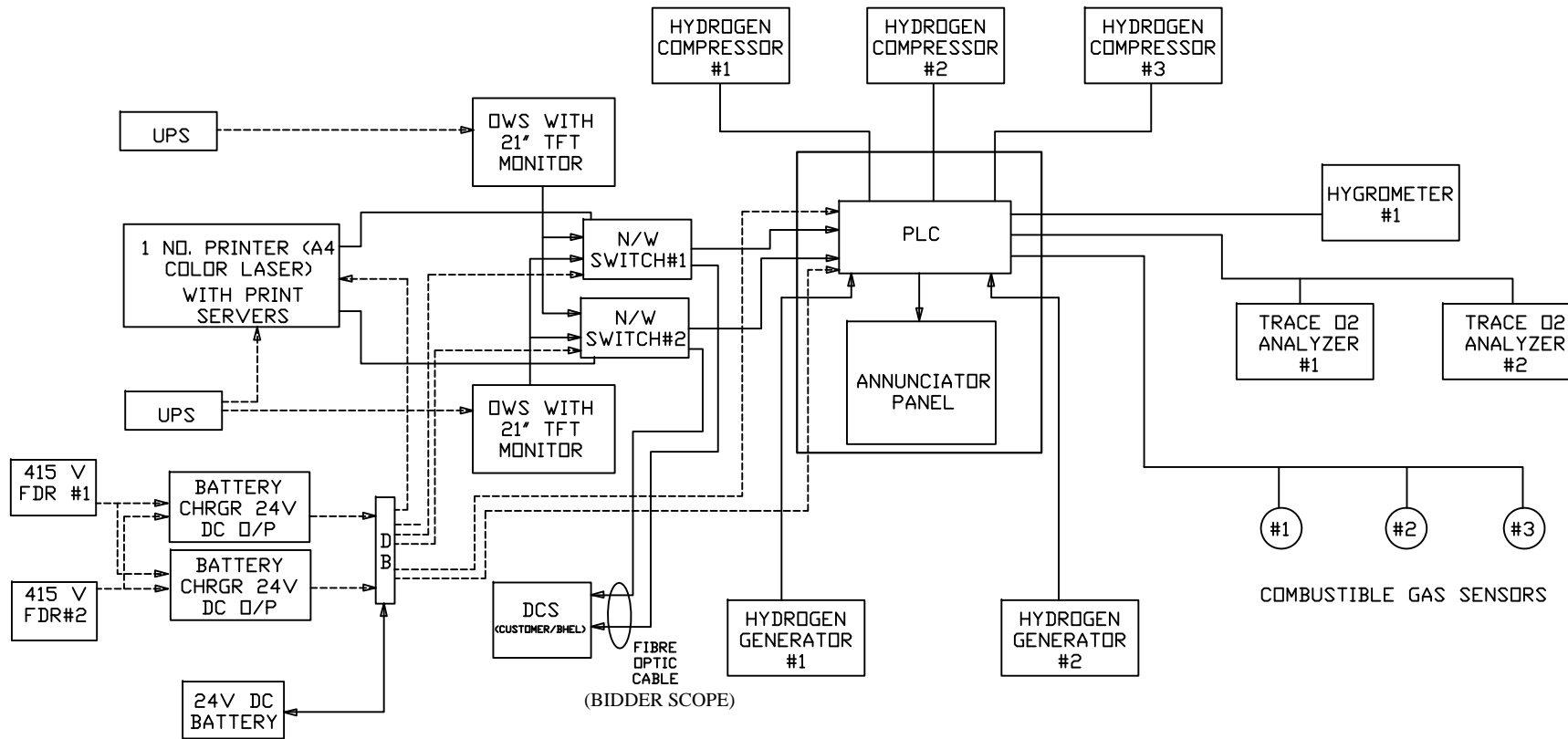

NOTES:

1. POWER TO PLC (IN THE ANNUNCIATOR PANEL) SHALL BE 24 V DC. BATTERY CHARGER AND BATTERY SHALL BE IN BIDDER'S SCOPE..
2. UPS FOR PC AND ITS MONITOR AND PRINTER SHALL BE SMART TYPE LINE INTERACTIVE TYPE WITH SOFTWARE AND HARDWARE ALONGWITH FEATURES OF SURGE SUPPRESSION & AVR FACILITY.
3. SELECTOR SWITCH SHALL BE PROVIDED IN PLC TO SELECT COLD STANDBY PROCESS INTO SERVICE.
4. FURNITURES FOR DWS, PRINTER SHALL BE IN BIDDER'S SCOPE.

<p>1.00.00</p> <p>1.01.00</p> <p>1.02.00</p> <p>1.03.00</p> <p>1.04.00</p> <p>1.05.00</p> <p>1.06.00</p> <p>1.07.00</p>	<p style="text-align: center;">PLANT AUXILIARY SYSTEM</p> <p>CONTROL AND INSTRUMENTATION FOR HYDROGEN GENERATION PLANT</p> <p>Contractor shall provide complete Control and Instrumentation system with all accessories, auxiliaries and associated equipments and cables for the safe, efficient and reliable operation of the plant auxiliary systems as indicated under scope part at IIC, Part-A, Section VI.</p> <p>The quantity of instruments for each plant auxiliary system shall be as per tender P&ID wherever provided of the respective system as a minimum, for bidding purpose. However, Bidder shall also include in his proposal all instruments and devices, which are needed for the completeness of the plant auxiliary system/equipment, supplied by the Contractor, even if the same is not specifically appearing in the P&ID.</p> <p>All electrical devices like switches/ transmitters/ controller/ analyzer/ solenoid valves which are located in the hydrogen generation plant shall be made intrinsically safe by providing suitable type of transformer isolated barrier/ Zenner barrier of standard make. Otherwise such instruments shall be provided with explosion proof enclosure suitable for hazardous areas described in National Electric Code (USA), Article 500, Class-I, Division-I or EN60079-14 or shall comply with the essential requirements of ATEX directives. All fittings, cable glands etc. shall be strictly as per NEC recommendation article, 500 to 503.</p> <p>Contractor shall provide PLC control systems for safe, efficient and reliable operation of each of the plant auxiliary systems. The type of control system shall be as indicated under scope part at IIC, Part-A, Section VI.</p> <p>Control, interlock/ protection, indication of incomers and bus-coupler (even if they are not in the scope of the contractor) are also to be performed from Contractor's Control System for each of the plant auxiliary system as applicable.</p> <p>It shall be possible to remove/replace online various modules (like any I/O module, interface module, etc.) from its slot for maintenance purpose without switching off power supply to the corresponding rack. System design shall ensure that while doing so, undefined signaling and releases do not occur and controller operation in any way is not affected (including controller trip to manual, etc) except that information related to removed module is not available to controller. Further, it shall also be possible to remove/replace of controller module without switching off the power to the corresponding rack and this will not result in system disturbance or loss of any controller functions for the other controller. The on-line removal/insertion of controller, I/O modules shall in no way jeopardize safety of plant and personnel.</p> <p>The control system shall provide safe operation under all plant disturbances and on component failure so that under no condition the safety of plant, personnel or</p>
--------------------------------------------------------------------------------------------------------------------------------	----------------------------------------------------------------------------------------------------------------------------------------------------------------------------------------------------------------------------------------------------------------------------------------------------------------------------------------------------------------------------------------------------------------------------------------------------------------------------------------------------------------------------------------------------------------------------------------------------------------------------------------------------------------------------------------------------------------------------------------------------------------------------------------------------------------------------------------------------------------------------------------------------------------------------------------------------------------------------------------------------------------------------------------------------------------------------------------------------------------------------------------------------------------------------------------------------------------------------------------------------------------------------------------------------------------------------------------------------------------------------------------------------------------------------------------------------------------------------------------------------------------------------------------------------------------------------------------------------------------------------------------------------------------------------------------------------------------------------------------------------------------------------------------------------------------------------------------------------------------------------------------------------------------------------------------------------------------------------------------------------------------------------------------------------------------------------------------------------------------------------------------------------------------------------------------------------------------------------------------------------------------------------------------------------------------------------------------------------------------------------------------------------------------------------------------------------------------------------------------------------------------------------------------------------------------------------------------------------------------------------------------------------------------------------------------------------------------------------------------------------------------------------------------------------------------------------------------------------------------------------------------------------------------------------------------------------------------------------------------------------------------------------------------------------------------------------------------

<p>1.08.00</p> <p>1.09.00</p> <p>2.00.00</p> <p>2.01.00</p> <p>2.02.00</p>	<p>equipment is jeopardized. Control system shall be designed to prevent abnormal swings due to loss of Control System power supply, failure of any Control System component, open circuit/short circuit etc.</p> <p>The Control system shall include on-line self-surveillance, monitoring and diagnostic facility giving the details of the fault on the Human Machine Interface System (HMIS). The faults to be reported shall include fault in main & standby power supplies, sensor fault, Input/ Output card failure, Memory Status, Controller fault, failure of Communication/ Network links to PLCs, LAN etc. These faults shall be reported as colour change on system status display and as messages on HMIS as well as through local indication on the faulty module and on respective rack/ cubicle. The diagnostic system shall ensure that the faults are detected before any significant change in any controller output has taken place.</p> <p>The Control system shall operate in non-air conditioned area and shall meet the minimum requirements as specified below.</p> <p>PROGRAMMABLE LOGIC BASED CONTROL SYSTEM</p> <p>PLC PROCESSOR</p> <p>The processor unit shall be capable of executing the following functions:-</p> <ul style="list-style-type: none"> a Receiving binary and analog signals from the field and providing command output to MCC/SWGR/Drive etc. through Input / Output modules and operator initiated commands from HMIS / control panel. b Implementing all logic functions for control, protection and annunciation of the equipment and systems. c Implementing modulating control function for certain application as specified elsewhere in the specification. d Providing supervisory information for alarm, various types of displays, status information, trending, historical storage of data etc. e Performing self-monitoring and diagnostic functions. <p>The memory shall be field expandable. The memory capacity shall be sufficient for the complete system operation and have a capability for at least 20% expansion in future. Programmed operating sequences and criteria shall be stored in non volatile semi conductor memories like EPROM. All dynamic memories shall be provided with buffer battery back up which shall be for at least 360 hours. The batteries shall be lithium or Ni-Cd type.</p>
-----------------------------------------------------------------------------------	----------------------------------------------------------------------------------------------------------------------------------------------------------------------------------------------------------------------------------------------------------------------------------------------------------------------------------------------------------------------------------------------------------------------------------------------------------------------------------------------------------------------------------------------------------------------------------------------------------------------------------------------------------------------------------------------------------------------------------------------------------------------------------------------------------------------------------------------------------------------------------------------------------------------------------------------------------------------------------------------------------------------------------------------------------------------------------------------------------------------------------------------------------------------------------------------------------------------------------------------------------------------------------------------------------------------------------------------------------------------------------------------------------------------------------------------------------------------------------------------------------------------------------------------------------------------------------------------------------------------------------------------------------------------------------------------------------------------------------------------------------------------------------------------------------------------------------------------------------------------------------------------------------------------------------------------------------------------------------------------------------------------------------------------------------------------------------------------------------------------------------------------------------------------------------------------------------------------------------------------------------------------------------------------------------------------------------------------------------------------------------------------------------------------------------------------------

2.03.00	Priority of different commands shall be as follows:
2.03.01	Manual intervention shall be possible at any stage of operation. Protection commands shall have priority over manual commands and manual commands shall prevail over auto commands.
2.03.02	A forcing facility shall be provided for changing the states of inputs and outputs, timers and flags to facilitate fault finding and other testing requirements. It shall be possible to display the signal flow during operation of the program.
2.04.00	HUMAN MACHINE INTERFACE SYSTEM (HMIS)
2.04.01	Operator work station (OWS) shall perform control, monitoring and operation of all auxiliaries/ drives interacting with PLC based control system. It shall be possible to use the same as programming station of the PLC and the Human Machine Interface System. It shall basically perform the following functions. In case the PC based OWS can not be used as programming station of the PLC and the Human Machine Interface System, then separate PC based programming station shall be provided.
2.04.02	Operator shall be able to access all control/information related data under all operating conditions including a single processor/computer failure in the HMIS.
2.04.03	All frequently called important functions including major displays shall be assigned to dedicated function keys on a soft keyboard for the convenience of the operator for quick access to displays & other operator functions.
2.04.04	The operator functions for each OWS shall as a minimum include Control System operation (A/M selection, raise/lower, set point/bias change, on/off, open/close operation, mode/device selection, bypassing criteria, sequence auto, start/stop selection, drive auto selection, local-remote/other multi-position selection etc.); alarm acknowledge; call all kind of displays, logs, summaries, calculation results, etc.; printing of logs & reports; retrieval of historical data; and any other functions required for smooth operation, control & management of information as finalized during detailed engineering.
2.04.05	The display selection process shall be optimized so that the desired display can be selected with the minimum no. of operations. Navigation from one display to any other should be possible efficiently through paging soft keys as well as through targets defined on the displays. There should be no limitation on number of such targets.
2.04.06	The system shall have built-in safety features that will allow/disallow certain functions and entry fields within a function to be under password control to protect against inadvertent and unauthorised use of these functions. Assignment of allowable functions and entry fields shall be on the basis of user profile. The system security shall contain various user levels with specific rights as finalised by the Employer during detailed engineering. However, no. of user levels, no. of users in a

	level and rights for each level shall be changeable by the programmer (Administrator).
2.05.00	When any drive or sequence is being controlled from one OWS, the system shall inhibit control access of the same drive or sequence from other OWS or Local Control Panel.
2.06.00	PROGRAMMING FUNCTIONALITIES
	Programming of the PLC Processor / controller as well as programming of HMIS shall be user friendly with graphical user interface and shall not require knowledge of any specialized language. For example, the programming of PLC shall use either of the following:-
	<ul style="list-style-type: none"> - Flow-chart or block logic representing the instructions graphically. - Ladder diagrams.
	The programming of HMIS (like development and modification of data base, mimics, logs / reports, HSR functionalities etc.) shall also be possible through user-friendly menus etc
	All programming functionalities shall be password protected to avoid unauthorized modification.
2.07.00	SOFTWARE REQUIREMENT
2.07.01	All necessary software required for implementation of control logic, operator station displays / logs, storage & retrieval and other functional requirement shall be provided. The programs shall include high level languages as far as possible. The contractor shall provide sufficient documentation and program listing so that it is possible for the Employer to carry out modification at a later date.
2.07.02	The Contractor shall provide all software required by the system for meeting the intent and functional/parametric requirements of the specification.
2.07.03	Industry standard operating system like UNIX/WINDOWS (latest version) etc. to ensure openness and connectivity with other system in industry standard protocols (TCP-IP/ OPC etc.) shall be provided. The system shall have user friendly programming language & graphic user interface.
2.07.04	All system related software including Real Time Operating System, File management software, screen editor, database management software. On line diagnostics/debug software, peripheral drivers software and latest versions of standard PC-based software and latest WINDOWS based packages etc. and any other standard language offered shall be furnished as a minimum.

2.07.05	All application software for PLC system functioning like input scanning, acquisition, conditioning processing, control and communication and software for operator interface of monitors, displays, trends, curves, bar charts etc. Historical storage and retrieval utility, and alarm functions shall be provided.
2.07.06	The Contractor shall provide software locks and passwords to Employer's engineers at site for all operating & application software so that Employer's engineers can take backup of these software and are able to do modifications at site.
2.08.00	<p>PARAMETRIC REQUIREMENTS</p> <p>The control system shall be designed such that under worst case loading conditions the response time shall not be worst than the following:-</p> <ul style="list-style-type: none"> On/Off Command - The response time for screen update after the execution of the control command from the time the command is issued (for example command to start a motor to the time the screen is updated) shall be two seconds (excluding the drive actuation time). Adjustment Command - 0.5 to 1 second. On screen Updating - 1 second. All Control related displays - 1 second. Bar Chart displays - 2 to 3 seconds. Plant Mimic displays - 2 to 3 seconds. Group review displays - 2 to 3 seconds. X-T Plot Displays - 1 to 2 seconds. Plant Summary Displays - 1 to 2 seconds. <p>Even under worst case loading condition of HMIS and system Bus, each HMIS processor shall have 50 % spare time when measured over any one minute period and the system bus shall have at least 50 % spare duty cycle.</p> <p>3.00.00 INPUT/OUTPUT MODULES</p> <p>3.01.00 The PLC system should be designed according to the location of the input/output cabinets as specified.</p> <p>3.02.00 Input Output modules, as required in the Control System for all type of field input signals (4-20 mA, RTD, Thermocouple, non change over/change over type of</p>
STEAM TURBINE GENERATION CONTROL	

	contact inputs etc.) and outputs from the control system (non change over/change over type of contact, 24/48 VDC output signals for energizing interface relays,4-20 mA output etc.) are to be provided by the Contractor. Contractor to refer drawing nos. 0000-999-POI-A-065 for interface/termination requirements of Field Instruments/Drives.
3.03.00	Electrical isolation of 1.5KV with optical couplers between the plant input/output and controller shall be provided on the I/O cards. The isolation shall ensure that any inadvertent voltage or voltage spikes (as may be encountered in a plant of this nature) shall not damage or mal-operate the internal processing equipment.
3.04.00	The Input/output system shall facilitate modular expansion in fixed stages. The individual input/output cards shall incorporate indications on the module front panels for displaying individual signal status.
3.05.00	Individually fused output circuits with the blower fuse indicator shall be provided. All input/output points shall be provided with status indicator. Input circuits shall be provided with fuses preferably for each input, alternatively suitable combination of inputs shall be done and provided with fuses such that for any fault, fuse failure shall affect the particular drive system only without affecting other systems.
3.06.00	All input/output cards shall have quick disconnect terminations allowing for card replacement without disconnection of external wiring and without switching of power supply.
3.07.00	The Contractor shall provide the following monitoring features: <ul style="list-style-type: none"> a Power supply monitoring. b Contact bounce filtering. c Optical isolation between input and output signals with the internal circuits d In case of power supply failure or hardware fault, the critical outputs shall be automatically switched to the fail-safe mode. The fail-safe mode shall be intimated to the successful Contractor during detailed engineering.
3.08.00	Binary Output modules shall be rated to switch ON/OFF coupling relays of approx. 3 VA at 24 VDC. Analog output modules shall be able to drive an load impedance of 500 Ohms minimum.
3.09.00	Output module shall be capable of switching ON/OFF inductive loads like solenoid valves, auxiliary relays etc. without any extra hardware.
3.10.00	Only one changeover contact shall be provided in MCC for control and interlock requirement. Further multiplication, if required, shall be done by the contractor in PLC system.

3.11.00	All input field interrogation voltage shall be 24V DC or 48 V DC.												
3.12.00	In case of loss of I/O communication link with the main processing unit, the I/O shall be able to go to predetermined fail safe mode (to be decided during detailed engineering) with proper annunciation.												
3.13.00	Wiring Scheme for inputs to control system shall be as follows:												
3.13.01	Each of the triple redundant binary & analog inputs shall be wired to separate input modules. Similarly each of the dual redundant binary & analog inputs shall be wired to separate input modules. These redundant modules shall be placed in different racks, which will have separately fused power supply distribution. Implementation of multiple measurement schemes of these inputs will be performed in the redundant hardware. Loss of one input module shall not affect the signal to other modules. Other channels of these modules can be used by other inputs of the same functional group.												
3.13.02	The single (i.e. non-redundant) binary & analog signal required for control purposes shall be wired as follows:												
3.13.03	All single analog & binary inputs including the limit switches of valves/dampers MCC/SWGR check-backs of all drives & information related signals shall be wired to single (i.e. non-redundant) input modules.												
3.13.04	The on-off status of HT drives etc, however, be wired to two input modules in parallel.												
3.14.00	Inputs and Outputs related to each of the redundant drives / equipments (eg. each of the 3x50 % drives, each of the storage vessel/sump/tank storing same fluid, each of the streams and its related drives etc.) shall be wired to separate input and output modules.												
3.15.00	<p>The signal conditioning functions like multiple measurement schemes, square root extraction for flow signals, pressure and temperature compensation, limit value computation can be performed either in the controllers or in signal conditioning and processing hardware outside controllers.</p> <p>The maximum number of inputs/outputs to be connected to each type of module shall be as follows:</p> <table border="0" data-bbox="423 1535 1300 1780"> <tr> <td style="padding-left: 20px;">1.</td> <td>Analog input module</td> <td style="text-align: right;">16</td> </tr> <tr> <td style="padding-left: 20px;">2.</td> <td>Analog output module</td> <td style="text-align: right;">16</td> </tr> <tr> <td style="padding-left: 20px;">3.</td> <td>Binary input module</td> <td style="text-align: right;">32</td> </tr> <tr> <td style="padding-left: 20px;">4.</td> <td>Binary output module</td> <td style="text-align: right;">32</td> </tr> </table>	1.	Analog input module	16	2.	Analog output module	16	3.	Binary input module	32	4.	Binary output module	32
1.	Analog input module	16											
2.	Analog output module	16											
3.	Binary input module	32											
4.	Binary output module	32											

	5. Analog input & output (combined)	16
	6. Binary input and output (combined)	32
3.16.00	Any single sensor/transducer/transmitter failure alarm shall be provided on programmer station screens for all sensors/transducers/transmitters. Similarly sensor break alarm for thermocouples etc. shall also be displayed on the screens.	
3.17.00	Contractor shall provide remote Input/Output modules Housed in free-standing cabinets/racks (with suitable redundant data link to the central PLC system) as specified. These Input/Output modules shall meet the technical requirements as mentioned in the above clauses. Further these Input/Output modules shall be designed to continuously work under the environment expected to be encountered in assigned areas without any air-conditioning support. Wherever the cable route distance of these I/O cabinets/racks exceeds a distance of 300 meters from the Central PLC, fiber optic data link has to be provided.	
4.00.00	SYSTEM SPARE CAPACITY	
4.01.00	Over and above the equipment and accessories required to meet the fully implemented system as per specification requirements, Control System shall have spare capacity and necessary hardware/ equipment/ accessories to meet following requirement for future expansion at site:	
4.02.00	10% spare channels in input/output modules fully wired up to cabinets TB.	
4.03.00	Wired-in "usable" space for 20% modules in each of the system cabinets for mounting electronic modules wired up to corresponding spare terminals in system cabinets. Empty slots between individual modules/group of modules, kept for ease in maintenance or for heat dissipation requirement as per standard practice of Contractor shall not be considered as wired-in "usable" space for I/O modules. Terminal assemblies (if any in the offered system), corresponding to the I/O modules shall be provided for above mentioned 20 % blank space.	
4.04.00	Each processor / controller shall have 30% spare functional capacity to implement additional function blocks, over and above implemented logic/ loops. Further, each processor / controller shall have spare capacity to handle minimum 30% additional inputs/ outputs of each type including above specified spare requirements, over and above implemented capacity. Each of the corresponding communication controllers shall also have same spare capacity as that of processor/controller.	
4.05.00	The Data communication system shall have the capacity to handle the additions mentioned above.	
4.06.00	Twenty (20) percent spare relays of each type and rating mounted and wired in cabinets TB. All contacts of relays shall be terminated in terminal blocks of cabinets.	

4.07.00	<p>The spare capacity as specified above shall be uniformly distributed throughout all cubicles. The system design shall ensure that above mentioned additions shall not require any additional controller/processor/ peripheral drivers in the system delivered at site. Further, these additions shall not deteriorate the system response time / duty cycle, etc. from those stipulated under this specification.</p>
5.00.00	DATA COMMUNICATION SYSTEM (DCS)
5.01.00	<p>The Communication System shall include a Main System Bus and Other applicable bus systems like cubicle bus, local bus, I/O bus etc.</p> <p>The DCS shall have the following minimum features :</p> <ul style="list-style-type: none"> a Communication controllers shall be provided to handle the communication between I/O Modules (including remote I/O) and PLCs and between PLCs and operator work station/HMI device. b The design shall be such as to minimise interruption of signals. It shall ensure that a single failure anywhere in the media shall cause no more than a single message to be disrupted and that message shall automatically be retransmitted. Any failure or physical removal of any station/module connected to the system bus shall not result in loss of any communication function to and from any other station/module. c Built-in diagnostics shall be provided for easy fault detection. Communication error detection and correction facility (ECC) shall be provided at all levels of communication. Failure of one bus and changeover to the standby system bus shall be automatic and completely bump less and the same shall be suitably alarmed/logged. e The design and installation of the system bus shall take care of the environmental conditions as applicable. f Data transmitting speed shall be sufficient to meet the responses of the system in terms of displays, control etc. plus 25% spare capacity shall be available for future expansion. g Passive coaxial cables or fibre optic cables shall be employed. <p>The Contractor shall furnish details regarding the communication system like communication protocol, bus utilisation calculations etc.</p>
5.02.00	<p>The PLC system shall be provided with necessary hardware and software for dual fibre optic connectivity & interconnection with station wide LAN (In Employer's Scope) for two - way transfer of signals for the purpose of information sharing. The plant information shall be made available through an Ethernet link following TCP/IP standard. The system shall be OPC compliant. The exact data structure shall be as</p>

decided during detailed engg. All required plant data shall be transferred to/from through this ensuring complete security. The exact number of points to be transferred through the above communication link and the format of the data shall be finalised during detailed engineering. The Contractor shall provide all assistance to the BOP C&I System (In Employer's Scope) Supplier including co-ordination and flow of required information etc. for display of all input points under alarm, connected to PLC or generated by PLC, on various operating stations on BOP C&I System (In Employer's Scope) and various client PCs on station LAN.

6.00.00 SYSTEM REACTION TIME

6.01.00 The reaction time of the programmable control system from input signals at the input cards to output of the associated signals or commands of the output card inclusive of programmed logic processing, comprising a mixture of logic gates, arithmetic operations and other internal operations shall be less than 100 milli seconds under the most arduous control system operating conditions.

7.00.00 OPERATOR INTERFACE DISPLAYS/LOGS/REPORTS

7.01.00 Suitable Operator Interface Displays/Logs/Reports for control operation & monitoring shall be provided. The details shall be finalized during detailed Engg. stage.

7.02.00 Minimum quantities shall be as follows:-

- 1 Various displays on the OWS shall as a minimum include P&ID displays or mimic, bar chart displays, X-Y & X-T plot (trend) displays, operator guidance message displays, group displays, plant start-up/shutdown message displays, system status displays etc. Number of displays and the exact functionality shall be on as required basis and as finalised during detailed engineering subject to the minimum quantities as given in subsequent clauses. For X-T & X-Y plots, the facility of providing a background grid on operator request shall be variable with adequate no. of divisions in both co-ordinates.
- 2 The minimum quantity of major types of displays per unit shall be as follows:

a)	Control displays (group/sub-group/sequence/loop)	(On as reqd. basis subject to 100 minimum)
b)	P&ID/ mimic display	100
c)	Bar chart	30
d)	X-T Plot	30

	e)	X-Y Plot (with superimposed operating curves + using user selectable stored data)	25 + 25
	f)	Group displays	30
	g)	Operator guidance message	10
	h)	System status & other diagnostic display	on as required basis
		The assignment for the above will be done by the contractor as per the requirement of operation of Contractor's system as well as for maintenance. The balance displays shall be left as spare for future modification/addition.	
8.00.00		HISTORICAL STORAGE AND RETRIEVAL SYSTEM (HSRS)	
8.01.00		The HSRS shall collect store and process system data from MMIPIS data base. The data shall be saved online on hard disk and automatically transferred to erasable long term storage media once in every 24 hours periodically for long term storage. Provision shall be made to notify the operator when hard disk is certain percentage full. The disk capacity shall be sufficient to store at least seven days data.	
8.02.00		The data to be stored in the above system shall include alarm and event list, periodic plant data, selected logs/reports. The data/information to be stored & frequency of storage and retrieval shall be as finalised during detailed engineering. The system shall provide user-friendly operator functions to retrieve the data from historical storage. It shall be possible to retrieve the selected data on OWS or printer in form of trend/report by specifying date, time & period. Further, suitable index files/directories shall also be provided to facilitate the same. The logs/reports for at least last seven (7) days shall be available on the disk.	
8.03.00		In addition to above, the system shall also have facility to store & retrieve important plant data for a very long duration (plant life) on portable long term storage media). These data will include any data from the database as well as processed/computed data based an various calculations/transformation. The retrieved data from long term storage media should be possible to be presented in form of X-T display, X-Y display, logs, reports, etc.	
9.00.00		CONTROL & POWER SUPPLY SCHEME	
9.01.00		General Requirements	
		Necessary redundant transformers and redundant chargers with 24 V DC battery back-up shall be provided by the Contractor to derive power supply from 415V, 3-phase 3-wire incomers to be arranged by the Contractor at the input terminals of power supply cabinets. The Contractor shall, however furnish all required hardware/	

	<p>equipment/ cubicles for conversion and/or stabilization of the power source provided by the Employer to all other levels which may be necessary for meeting the individual requirements of equipments/ systems furnished by him within the Contractor's quoted lump sum price.</p> <p>The 24 V DC power supply system configuration shall be provided as per Appendix-1, Section VI, Part – A of specifications</p>
10.00.00	CONTROL CABINETS / PANELS
10.01.00	<p>The cabinets shall be IP-22 protection class. The Contractor shall ensure that the packaging density of equipment in these cabinets is not excessive and abnormal temperature rise, above the cabinet temperature during normal operation or air-conditioning failure, is prevented by careful design. This shall be demonstrated to the Employer during the factory testing of the system. The Contractor shall ensure that the temperature rise is limited to 10 deg. C above ambient and is well within the safe limits for system components even under the worst condition as specified in Sub-section-basic Design criteria (Part-B, Section-VI) and specification requirements for remote I/O cabinets. Ventilation blowers shall be furnished as required by the equipment design and shall be sound proof to the maximum feasible extent. If blowers are required for satisfactory system operation, dual blowers with blower failure alarm shall be provided in each cabinet with proper enclosure and details shall be furnished with proposal. Suitable louvers with wire mesh shall be provided on the cabinet.</p>
10.01.01	<p>The cabinets shall be designed for front access to system modules and rear access to wiring and shall be designed for bottom entry of the cables.</p>
10.01.02	<p>The cabinets shall be totally enclosed, free standing type and shall be constructed with minimum 2 mm thick steel plate frame and 1.6 mm thick CRCA steel sheet or as per supplier's standard practice for similar applications, preferred height of the cabinet is 2200 mm. The cabinets shall be equipped with full height front and rear doors. The floor mounting arrangement for other cabinets shall be as required by the Employer and shall be furnished by the Contractor during detailed engineering.</p>
10.01.03	<p>Cabinet doors shall be hinged and shall have turned back edges and additional bracing where required ensuring rigidity. Hinges shall be of concealed type. Door latches shall be of three-point type to assure tight closing. Detachable lifting eyes or angles shall be furnished at the top of each separately shipped section and all necessary provisions shall be made to facilitate handling without damage. Front and rear doors shall be provided with locking arrangements with a master key for all cabinets. If width of a cabinet is more than 800 mm, double doors shall be provided.</p>
10.01.04	<p>Two spray coats of inhibitive epoxy primer-surface shall be applied to all exterior and interior surfaces. A minimum of 2 spray coats of final finish colour shall be applied to all surfaces. The final finished thickness of paint film on steel shall not be less than</p>

	<p>65-75 micron for sheet thickness of 2 mm and 50 microns for sheet thickness of 1.6 mm. The finish colors for exterior and interior surfaces shall conform to following shades:</p> <p>(a.) Exterior:- As per RAL 9002 (End panel sides RAL 5012), to be finalized during detailed engineering.</p> <p>(b.) Interior:- Same as above.</p>
10.01.05	Paint films which show sags, checks or other imperfections shall not be acceptable.
10.01.06	As an alternative, single coat of anodic dipcoat primer along with single textured powder coating with epoxy polyester meeting the thickness requirement is also acceptable.
10.01.07	Refer Subsection Basic Design Criteria, Part B, and Section VI for grounding requirements.
10.01.08	The mimic shall be configured on the OWS and it shall be possible to control, monitor and operate the plant from the same.
10.01.09	The technical specification covering panel fabrication details, wiring and termination details etc. shall be as described under Sub-Section INST CABLE of this specification.
11.00.00	ANNUNCIATION SYSTEM
11.01.00	Only OWS based alarm system shall be provided with audio alarm facility (beep/tone generator). No facia annunciation is envisaged in the control room. Hooters are to be provided.
11.02.00	The system shall display history of alarms in chronological order on any of the OWS. The HMIS shall have the capability to store a minimum of 500 alarms each with paging features allowing the operator to view any page. The system shall have all alarm functions and related function keys like alarm acknowledge, reset, paging, summaries etc. Other design features like set point/dead band adjustments, provision of alarm priority, manual inhibition & automatic inhibition based on predefined logic etc., shall be provided and shall be as finalised during detailed engineering. The alarm display/report format shall be as approved by the Employer.
11.03.00	Facility of audio annunciation shall be provided in OWS upon the occurrence OWS alarms irrespective of whether alarms are displayed or not. Facility to disable the audio annunciation shall be provided.
11.04.00	At least three levels of alarm priority shall be available which will be displayed in different colour. It shall be possible to display & print alarms of any of the three levels.

11.05.00	The annunciator sequence shall conform to ISA sequence ISA-2A..														
12.00.00	SOFTWARE DOCUMENTATION AND SOFTWARE LISTINGS														
12.01.00	All technical manuals, reference manuals, user's guide etc., in English required for modification/editing/addition/deletion of features in the software of the PLC System shall be furnished. The Contractor shall furnish a comprehensive list of all system/application software documentation after system finalization for Employer's review and approval.														
12.02.00	All The software listings including Source code for application software, All special - to-project data files etc. shall be submitted by the Contractor.														
13.00.00	<p>SOFTWARE LICENCES</p> <p>The Contractor shall provide software license for all software being used in Contractor's System. The software licenses shall be provided for the project (e.g. organisation or site license) and shall not be hardware/machine-specific. That is, if any hardware/machine is upgraded or changed, the same license shall hold good and it shall not be necessary for Employer to seek a new license/renew license due to upgradation/change of hardware/machine in Contractor's System at site. All licenses shall be valid for the continuous service life of the plant.</p> <p>As a customer support, the Contractor shall periodically inform the designated officer of the Employer about the software upgrades/new releases that would be taking place after the system is commissioned so that if required, same can be procured & implemented at site.</p>														
14.00.00	<p>(A) SPECIFICATIONS OF OWS</p> <table border="1" data-bbox="483 1188 1459 1791"> <tr> <td colspan="2" data-bbox="483 1188 1459 1255">The minimum requirement for PC based OWS shall be as below:</td> </tr> <tr> <td data-bbox="483 1255 797 1318">CPU</td> <td data-bbox="797 1255 1459 1318">Latest generation CPU</td> </tr> <tr> <td data-bbox="483 1318 797 1381">Main memory</td> <td data-bbox="797 1318 1459 1381">1 GB expandable to 4 GB</td> </tr> <tr> <td data-bbox="483 1381 797 1444">Drives</td> <td data-bbox="797 1381 1459 1444">3 1/2" floppy drive, 48 x CD ROM drive</td> </tr> <tr> <td data-bbox="483 1444 797 1507">Hard disk</td> <td data-bbox="797 1444 1459 1507">80 GB</td> </tr> <tr> <td data-bbox="483 1507 797 1654">Removable bulk storage drive (MOD / DVD / DAT)</td> <td data-bbox="797 1507 1459 1654">8 GB (minimum)</td> </tr> <tr> <td data-bbox="483 1654 797 1791">Removable Bulk Storage Media for above</td> <td data-bbox="797 1654 1459 1791">10 nos</td> </tr> </table>	The minimum requirement for PC based OWS shall be as below:		CPU	Latest generation CPU	Main memory	1 GB expandable to 4 GB	Drives	3 1/2" floppy drive, 48 x CD ROM drive	Hard disk	80 GB	Removable bulk storage drive (MOD / DVD / DAT)	8 GB (minimum)	Removable Bulk Storage Media for above	10 nos
The minimum requirement for PC based OWS shall be as below:															
CPU	Latest generation CPU														
Main memory	1 GB expandable to 4 GB														
Drives	3 1/2" floppy drive, 48 x CD ROM drive														
Hard disk	80 GB														
Removable bulk storage drive (MOD / DVD / DAT)	8 GB (minimum)														
Removable Bulk Storage Media for above	10 nos														

Monitor	19" Full Flat TFT Resolution 1600 x 1280, refresh rate min 85 Hz.	
Graphic Memory	16 MB	
Communication port	2 serial plus, one parallel, 4 USB port, Dual 100 Mbps Ethernet.	
Expansion slots	3	
Other Features	101 Keys Keyboard and Optical Mouse	
UPS	1 no. On-line Interactive UPS with 30 mins. battery backup on machine load (for PC & its printer)	
Software	a	General MS Windows latest version, MS-Office, Microsoft Visual Studio, Adobe Acrobat, anti-virus McAfee or equivalent, etc.
	b	Application software - to suit project specific requirement
Accessories	Required furniture for mounting of HMI peripherals shall be provided.	

(B) GIU Refer Appendix to Part-A FOR QTY.

15.00.00

PRINTER

15.01.00

One number A4 size color laser printer at hydrogen generation plant control room shall be provided as a part of the HMIS system. It shall print out all alarm/trip conditions and event changes in plant status along with date and time of occurrence.

CLAUSE NO.

TECHNICAL REQUIREMENTS





1.01.10	6	Keys	Function keys and numeric keys	
	7	Interfacing requirements	Interface with respective control systems	
	8	Functional requirements	Ability to operate drives locally using function keys. Ability to do programming. Graphics display including alarms and operator guidance messages.	
	Printers			
	Sr. No	Features	Colour Laser Printer	Colour Laser Printer
	1	Paper Size	A3	A4
	2	Printing Speed (min.)- in normal mode for A4 size paper	6 ppm (Color)	4 ppm (color)
			24 ppm (B&W)	16 ppm (B&W)
	3	Type	Heavy duty, at least 50000 pages/month	Heavy duty, at least 30000 pages/month
	4	Resolution (black) (min.)	600 dpi	600 dpi
5	First page out time (with full graphic display)	=<1 min for color,	=<1 min for color,	
		<45 sec for BW	<45 sec for BW	
6	Paper input capacity (min.)	500 sheets	500 sheets	
7	Additional features	Automatic Duplex Printing		
8	Paper sheets	20 reams (A3)	20 reams (A4)	

CLAUSE NO.	TECHNICAL REQUIREMENTS			
		(1 ream = 500 sheets) with each printer	20 reams (A4)	
	9	Additional Cartridge/toner/ ribbon of each type as used in printer with each printer	1	1
1.01.11	Specification of PC/Lap TOP The Specification of PC/LAP TOP shall be as per the specific requirement of application and shall be as per OEM recommendation			
1.01.12	NOT USED			
1.01.13	NOT USED			
1.01.14	Firewall : Firewall appliance should facilitate multi-vendor, multi-application environment and should support third-party products on open alliance. It should support Active-Active configuration. <ul style="list-style-type: none"> <input type="checkbox"/> The firewall should contain following features: <ul style="list-style-type: none"> (a) Stateful inspection of packets. (b) NAT functionality, including dynamic and static NAT translations (c) Latest version of SNMP <input type="checkbox"/> The firewall must send log information to a separate log server via an encrypted connection. Firewall logging must not impact firewall performance. <input type="checkbox"/> Remote network access to the firewall should only be possible through the administration interface. <input type="checkbox"/> The firewall administration station must be capable of pushing firewall security policies and configurations to individual or multiple firewalls through a secure, encrypted connection to the firewall administration interfaces. <input type="checkbox"/> Graphical User Interface (GUI) and a Command Line Interface (CLI) for making changes to the firewall rules set should be provided. (Access to the 			

CLAUSE NO.	SCOPE OF SUPPLY & SERVICES															
9.00.00	CONTROL AND INSTRUMENTATION FOR PLANT AUXILIARY SYSTEMS															
9.01.00	Instrumentation and Control System with interlocks, protection and annunciation of the mechanical common auxiliary systems as mentioned below shall be provided. Instrumentation for this system shall meet the requirement stipulated under Sub-section Aux. Plant. Ctrl, Part -B, Section-VI of Technical Specification. All necessary equipments / system for control, monitoring and operations of the plants as well as the incomers and bus couplers shall be provided.															
9.02.00	For certain plants, control systems shall be provided as indicated below:															
	<table border="1"> <thead> <tr> <th data-bbox="419 678 518 741">SI No</th> <th data-bbox="518 678 740 741">Auxiliary Plant</th> <th data-bbox="740 678 1126 741">Control System</th> <th data-bbox="1126 678 1391 741">HMIPIS etc.</th> </tr> </thead> <tbody> <tr> <td data-bbox="419 741 518 1317">01</td> <td data-bbox="518 741 740 1317">Hydrogen Plant</td> <td data-bbox="740 741 1126 1317">Independent Microprocessor based / PLC based control system as per vendor's standard practice with redundant cold standby processor.(Refer relevant Tender Drawing for the configuration)</td> <td data-bbox="1126 741 1391 1317">Microprocessor based / PLC based with Two number Operator Workstations cum programming station, one number A4 size Color Laser printer. Dual two way Ethernet Connectivity utilising OPC to employer Station LAN for information.</td> </tr> <tr> <td data-bbox="419 1317 518 1585">02</td> <td data-bbox="518 1317 740 1585">Lub oil purification system(Main Turbine and Central Lub oil purification system)</td> <td data-bbox="740 1317 1126 1585">Local control panel for local operation and interface to TG control system controls</td> <td data-bbox="1126 1317 1391 1585"></td> </tr> </tbody> </table>				SI No	Auxiliary Plant	Control System	HMIPIS etc.	01	Hydrogen Plant	Independent Microprocessor based / PLC based control system as per vendor's standard practice with redundant cold standby processor.(Refer relevant Tender Drawing for the configuration)	Microprocessor based / PLC based with Two number Operator Workstations cum programming station, one number A4 size Color Laser printer. Dual two way Ethernet Connectivity utilising OPC to employer Station LAN for information.	02	Lub oil purification system(Main Turbine and Central Lub oil purification system)	Local control panel for local operation and interface to TG control system controls	
SI No	Auxiliary Plant	Control System	HMIPIS etc.													
01	Hydrogen Plant	Independent Microprocessor based / PLC based control system as per vendor's standard practice with redundant cold standby processor.(Refer relevant Tender Drawing for the configuration)	Microprocessor based / PLC based with Two number Operator Workstations cum programming station, one number A4 size Color Laser printer. Dual two way Ethernet Connectivity utilising OPC to employer Station LAN for information.													
02	Lub oil purification system(Main Turbine and Central Lub oil purification system)	Local control panel for local operation and interface to TG control system controls														
10.00.00	TYPE TEST REQUIREMENT															
10.01.00	The type tests to be conducted for C&I systems & equipments shall be as detailed out in Sub-Section C&I TYPE TEST, Part-B, Section-VI of Technical Specification.															

CLAUSE NO.	SCOPE OF SUPPLY & SERVICES				
11.00.00	OTHER INTERFACING REQUIREMENT TO/FROM EMPLOYERS PROCURED CONTROL AND INSTRUMENTATION SYSTEM				
SI No	Employer procured system	Brief Description of the system	Interfacing Requirement	Specific requirements	
01	PLANT PERFORMANCE ANALYSIS, DIAGNOSIS & OPTIMIZATION SOFTWARE	<p>A PC based On-line Plant Performance Analysis, Diagnosis & Optimization system (PADO) for the station is being procured by Employer in a separate package which will carry out the following functions as detailed below. The PADO system shall provide the following functions in a modular and seamlessly integrated environment, using a common plant model and a dynamically shared database</p> <ul style="list-style-type: none"> • Performance analysis and monitoring of systems and components. • Emission Analysis and monitoring. • System and performance diagnosis. • System and performance optimization. • Boiler 	<p>The Contractor shall be required to furnish all the P&ID's in his scope ,Heat Balance diagrams, Heat Rate correction curves, Data sheets of equipments e.g Heaters, Condenser, Pumps, Generator etc.. for proper development and improvements of PADO.</p> <ul style="list-style-type: none"> • The system shall use the measured data from the Bidder's DDCMIS through appropriate interface to be provided by the bidder 	<p>The no of analog signals and Binary signals required from contractor supplied DDCMIS system are approximately 250 Analog (including calculated) and 50 Binary signals. How-ever any other signal if required during detailed engineering shall also be supplied on as required basis. The individual signal data transfer rate shall not exceed 1 minute .</p>	

CLAUSE NO.	SCOPE OF SUPPLY & SERVICES				
			<p>performance optimizations including optimized operation of soot Blowing system.</p> <ul style="list-style-type: none"> Boiler stress condition analysers. Interactive water and gas chemistry management system. Regenerative cycle performance optimization system. 	<p>through employers procured station LAN/ Unit LAN</p>	
	02	TG-Soft link to employer DDCMIS	<p>(a) Redundant signal exchange to employer HMIPIS utilizing Ethernet/ OPC based communication system for Alarms, analysis softwares, Logs, MIMICS,ERP interfaces</p> <p>(b) LVS annunciation system</p>	Redundant Ethernet based OPC link	<p>(a) All Analog signal transfer at 1 second except for temperature points ,which shall be as per the process update rate.</p> <p>(b) All drives status</p> <p>(c) In case LVS based annunciation are not offered by the Bidder, then all the time stamped alarms and critical DDCMIS diagnostics events generated in</p>

CLAUSE NO.	SCOPE OF SUPPLY & SERVICES			
				 <p>Bidder's DDCMIS system shall be transferred to Employer's DDCMIS system utilizing OPC communication links.</p>
	03	SOE system	Integrated SOE is being procured by the employer	<p>Potential free Signals contacts from the Bidders supplied DDCMIS system</p> <p>Quantity of SOE signal shall be approximately 100 Nos How-ever these are the minimum quantities to be considered. Bidder to supply the same as on required basis.</p>
	04	HART instruments /Device Connectivity	HART management System is Employer's Scope	<p>Terminations for connecting instruments/Device to connect with employer's procured HART Management System.</p> <p>In case online programming by employer procured HART management system is not allowed for the instruments/devices, that are being offered as a part of standard and proven instrumentation for STG integral controls and TDBFP integral Controls, the transmitter's/DDCMIS system would be provided with the necessary capability to be interfaced with the employer procured HART Management</p>

CLAUSE NO.	SCOPE OF SUPPLY & SERVICES				
					<p>system after the system is handed over to the employer.</p>
	05	H/W signal exchange for employer procured control system	Open Loop Control system, Closed loop Control system (CMC etc), Protection system (such as RH protection) are being implemented in a employer procured control system	All the standard hardwired signals to/from the bidder's /employer control system required for implementing the control and protection strategies shall be provided	<p>For quantity estimation of these signal following minimum quantities/types to be considered. 30-AO 5-AI 50- DI 75-DO</p> <p>How-ever these are the minimum quantities to be considered.</p> <p>Bidder to supply the same on as required basis.</p>
12.00.00	OTHER SCOPE OF ENGG SERVICES				
12.01.00	<p>All control ,monitoring and operations of all equipments/systems that are defined under "Terminal Point and exclusions" chapter in Part-A of this specification are being controlled through microprocessor based Distributed Digital Control Monitoring and Information System (DDCMIS) being procured by Employer under separate package (Station C&I Package). This DDCMIS system shall perform all functions such as auto / manual operation of valves, pumps, drives, local / remote selection of operation, status indication, annunciation, interlock and protection of pumps/drives etc.</p>				
12.02.00	<p>For successful implementation of the same, the Contractor shall furnish all the required details/drawings/data/information like list of drives to be controlled, write-ups for controls, interlock and protection of Contractor's equipment, recommended control loops, External connection diagrams or any other data etc as might be required by Employer during detailed Engineering stage without any cost repercussion.</p>				

CLAUSE NO.	SCOPE OF SUPPLY & SERVICES	
12.03.00	The logics diagram for the above shall also be provided by the bidder to the employer, for implementing the control schemes in employer's procured control system.	
12.04.00	The Bidder shall provide the comprehensive engineering documents such as IO list, Drive list, instrument schedule, JB grouping document etc in the reusable MS Excel format. The typical formats for these are also enclosed with this specification. These documents are required for all the instruments/drives/signals that are covered in this scope of work.	
12.05.00	NOT USED	
12.06.00	The Contractor's representative shall be present at the time of Factory Acceptance test of the above mentioned Control System being procured by Employer at finally selected Employer Vendor's works.	
12.07.00	Contractor shall provide all necessary supervision/assistance for proper commissioning of his equipment to Control System Supplier through Employer.	
12.08.00	The Contractor shall provide KKS codes for all instruments and drives in the scope of work. The list of kks codes to be adopted by the bidder are also being provided along with this specification.	
13.00.00	TOOLS & TACKLES	
13.01.00	The Contractor shall furnish a complete new set of all special tools and tackles of reputed make and model which are required for erection, ease in maintenance to have minimum down time, testing and calibration of all the equipments and systems to be provided by the Contractor under this specification for C&I systems.	

CLAUSE NO.	SCOPE OF SUPPLY & SERVICES	
<p>1.00.00</p> <p>2.00.00</p> <p>3.00.00</p> <p>3.01.00</p>	<p>APPENDIX-1 TO C&I (CONTRACT QUANTITY FOR STG C&I SYSTEM)</p> <p>GENERAL REQUIREMENTS OF CONTRACT QUANTITIES</p> <p>The scope of C&I systems under this specification Steam Turbine and Generator (STG) C&I system is covered in Part-A and Part-B of this specification. The purpose of this appendix is to supplement the scope given in Part-A and the specification requirements given in Part-B of technical specification and is not intended to give total Scope. The Contract quantities of many subsystems covered under Part-A and Part-B of technical specification are generally not reproduced here to avoid duplication. However, in case of any conflict or repetition, the more stringent requirements among them are to be complied with.</p> <p>NOT USED</p> <p>Contractor should note that he has to supply system complete in all respects with all software, hardware, accessories, interfacing equipment required, etc., whether specifically stated herein or not, to make the system operational and fully meeting the functional, parametric, hardware, software, interfacing, quality assurance & testing requirements within the quoted lumpsum price.</p> <p>The Contractor shall provide functional groups as per the following guidelines.</p> <p>(I) STG integral controls (i.e. Close loop control (CLC) ,Open loop Control(OLC) and protection pertaining to steam turbine and generator) block:- The contractor shall provide functional group(s) for the Turbine protection and Turbine EHTC block, Automatic Turbine Testing, TSE's, Gland steam system controls, Turbine and Generator Auxiliaries including ATRS, Oil System, Vacuum system, seal oil system, stator water system etc., The functional group(s) consist of set(s) of controllers, I/O modules, communication controllers, power packs/modules. The configuration of this function group shall be as per standard & proven practice of the Bidder.</p> <p>(II) Over and above the STG integral controls block envisaged above, the Contractor shall also provide functional groups as per the following guidelines. The TG control system is divided into different process blocks. For different process blocks, separate sets of FG(s) are to be provided. For definition and requirements of function groups (FGs), refer Section VI,part-B,IIIC-02,clause 4.00.00. The process blocks of the TG control system are defined below. It may be noted that the process areas, equipment, logic, loops given below cover major areas of control. The exact areas/control shall be subject to employer's approval during detailed engineering stage.</p>	

CLAUSE NO.	SCOPE OF SUPPLY & SERVICES	
	<p>a. BFP Drive Turbine-A block: This block will consist of BFP Drive Turbine-A OLCS and CLCS controls, including EHTC of Drive Turbine-A and Auxiliaries of Drive Turbine-A.</p> <p>b. BFP Drive Turbine-B block: This block will consist of BFP Drive Turbine-B OLCS and CLCS controls, including EHTC of Drive Turbine-B and Auxiliaries of Drive Turbine-B.</p> <p>c. Balance control implementation :- The remaining controls envisaged in the scope of the work such as HP/LP bypass system, condenser on load tube cleaning system, SCS, CPU Controls, Turbine lube oil purification control, central lub oil purification control etc. can be implemented in any of the above process blocks or separately as per the Bidder's standard and proven practice. The exact implementation methodology ,how-ever shall be strictly as approved by Employer during detailed engineering.</p> <p>d. If it is a standard and proven practice of the bidder to offer proprietary integral controls for the systems/equipments listed at a) b) and c) ,the same shall also be acceptable how-ever these systems shall be interfaced suitably with the offered DDCMIS system so as to realize a unified HMIPIS for plant, operation monitoring and controls. For each such proprietary control suitable programming kit/device/station shall also be supplied. The exact interfacing details shall be as finalised during detailed engineering and subject to employer approval.</p>	
3.02.00	Input/output signal multiplication, and distribution of process, system and software generate points, etc. required within the system are to be provided by the Contractor on as required basis.	
3.03.00	For signal exchange with BOP C&I systems, Contractor shall provide suitable data link/interface as specified in item Signal Exchange, Subsection DDCMIS, Part B, Section VI. of the specification. The no of such signals shall be as identified under Section-VI, Part-A .However signals required to be exchanged between SG/BOP C&I systems for protection of Turbine, Boiler and other HT drives as well as for CMC shall be hardwired. The same shall be provided on as required basis.	
3.04.00	The spare capacity for the system as indicated under item System Spare capacity, Subsection DDCMIS, Part B, Section VI shall be included and provided by the Contractor.	
3.05.00	The contact rating of "DO (contact)" type outputs from control system shall be as follows. The contact rating for such outputs for Unit DDCMIS shall be minimum 60VA, and shall be suitable for contact interrogation at 24 V DC. For such outputs	

CLAUSE NO.	SCOPE OF SUPPLY & SERVICES														
4.00.00	<p>for other DDCMIS systems relays shall be provided for each of such outputs, and the rating of contacts of the relays shall be as specified in Part-B of specification.</p> <p>The following back-up instrumentation and Secondary instruments shall be provided by the Employer as a minimum for TG applications. Contractor has to supply all the required input output modules in TG C&I part of DDCMIS for interface of these modules without any cost implication to the employer. The quantity indicated here is for each unit.</p> <table border="1" data-bbox="419 607 946 853"> <tr> <td data-bbox="419 607 515 678">(i)</td> <td data-bbox="515 607 738 678">2 PB + 3 LED</td> <td data-bbox="738 607 946 678">5</td> </tr> <tr> <td data-bbox="419 678 515 750">(ii)</td> <td data-bbox="515 678 738 750">TRIP PB</td> <td data-bbox="738 678 946 750">1</td> </tr> <tr> <td data-bbox="419 750 515 853">(iii)</td> <td data-bbox="515 750 738 853">RECESSED PB(Release)</td> <td data-bbox="738 750 946 853">1</td> </tr> </table>			(i)	2 PB + 3 LED	5	(ii)	TRIP PB	1	(iii)	RECESSED PB(Release)	1			
(i)	2 PB + 3 LED	5													
(ii)	TRIP PB	1													
(iii)	RECESSED PB(Release)	1													
5.00.00	NOT USED														
6.00.00	<p>LIST OF AREAS FOR WHICH SOFT SIGNALS IS TO BE CONNECTED TO STEAM TURBINE AND GENERATOR (STG) C&I SYSTEM</p> <table border="1" data-bbox="419 1021 1414 1335"> <thead> <tr> <th data-bbox="419 1021 493 1160">SI No.</th> <th data-bbox="493 1021 707 1160">Area</th> <th data-bbox="707 1021 916 1160">Connected to the DDCMIS System</th> <th data-bbox="916 1021 1102 1160">Minimum Qty of links/ Location</th> <th data-bbox="1102 1021 1259 1160">Type</th> <th data-bbox="1259 1021 1414 1160">Qty of signals</th> </tr> </thead> <tbody> <tr> <td data-bbox="419 1160 493 1335">1.</td> <td data-bbox="493 1160 707 1335">TG Charger in each unit</td> <td data-bbox="707 1160 916 1335">TG C&I of respective unit</td> <td data-bbox="916 1160 1102 1335">04 Nos. / Charger Room per unit</td> <td data-bbox="1102 1160 1259 1335">RS 485 / RS232</td> <td data-bbox="1259 1160 1414 1335">40 per charger</td> </tr> </tbody> </table>			SI No.	Area	Connected to the DDCMIS System	Minimum Qty of links/ Location	Type	Qty of signals	1.	TG Charger in each unit	TG C&I of respective unit	04 Nos. / Charger Room per unit	RS 485 / RS232	40 per charger
SI No.	Area	Connected to the DDCMIS System	Minimum Qty of links/ Location	Type	Qty of signals										
1.	TG Charger in each unit	TG C&I of respective unit	04 Nos. / Charger Room per unit	RS 485 / RS232	40 per charger										
7.00.00	<p>PLC BASED CONTROL SYSTEMS</p> <table border="1" data-bbox="408 1397 1422 1742"> <thead> <tr> <th data-bbox="408 1397 485 1503">SI No.</th> <th data-bbox="485 1397 671 1503">Area</th> <th data-bbox="671 1397 975 1503">Description of Control system</th> <th data-bbox="975 1397 1422 1503">Quantity</th> </tr> </thead> <tbody> <tr> <td data-bbox="408 1503 485 1742">1.</td> <td data-bbox="485 1503 671 1742">Hydrogen Generation Plant</td> <td data-bbox="671 1503 975 1742">Microprocessor/PLC based Control system as per manufacturer's standard practice with redundant cold stand-by processor.</td> <td data-bbox="975 1503 1422 1742">1 Set (as per the configuration drawing)</td> </tr> </tbody> </table>			SI No.	Area	Description of Control system	Quantity	1.	Hydrogen Generation Plant	Microprocessor/PLC based Control system as per manufacturer's standard practice with redundant cold stand-by processor.	1 Set (as per the configuration drawing)				
SI No.	Area	Description of Control system	Quantity												
1.	Hydrogen Generation Plant	Microprocessor/PLC based Control system as per manufacturer's standard practice with redundant cold stand-by processor.	1 Set (as per the configuration drawing)												

CLAUSE NO.

SCOPE OF SUPPLY & SERVICES



8.00.00

THE QUANTITIES OF OTHER EQUIPMENT RELATED TO CONTROL SYSTEM, HMIPIS ETC IS AS FOLLOWS.

Sl. No.	Item Name	Unit	DDCMIS	Remarks
1.0	Control System		Qty./Unit	
1.1	Functional groups	Nos.	As per the guidelines indicated in Appendix-1 to C&I contract quantities part-A.	
1.2	Control Cabinets for housing Control system hardware	Nos.	On as required basis	
1.3	(a) Control Cabinets for housing Remote I/O's hardware for Service vessel/unit and CPU Regeneration system. (b)Control Cabinets for housing Remote I/O hardware (wherever specified/applicable)	Nos.	On as required basis On as required basis	
1.4	Marshalling Cabinets, Termination cabinets, Relay Cabinets	Nos.	On as required basis as per the applicability of these cabinets in line with specification requirement	
1.5	Relays	Nos.	On as required basis	
1.6	Cubicles for mounting network components & power supply distribution equipment	Nos.	On as required basis	
2.0	Human Machine Interface			

CLAUSE NO.	SCOPE OF SUPPLY & SERVICES				
	2.1	Redundant Servers (Only for Alternative 1)	Sets	1	1 set is Two Nos. servers minimum.
	2.2	Operator Work Stations	Nos.	2	The function of OWS can be implemented in the server itself for Alternate-1
	2.3	Programming station	Nos.	1	If system documentation facility is not part of this station, separate workstations shall be provided for the same.
	2.4	Information Work Stations (only for Alternative-II)	Nos.	2	The function of information Workstations can be merged with each of the OWS.
	2.5	Large Video Screens(LVS)	Nos.	Nil	Screens are being procured by Employer under Station C&I package
	2.6	Work Station for LVS	Nos.	2	
	2.7	Suitable redundant interfaces and redundant links for connectivity between Unit LAN/ station wide LAN, and DDCMIS sub systems, unit/station PLCs, PC stations, PADO, Remote Service Centre as applicable.	Sets	1	Each set will include components for respective remote I/O & FGs.

CLAUSE NO.	SCOPE OF SUPPLY & SERVICES				
	2.8	Control System Programming device including EPROM Writer/eraser etc. (if applicable)	Nos.	2	This item is not required in case not applicable.
	2.9	Data Communication System		As required basis	
	2.10	Remote Service centre hardware		As required basis	
	3.0	Printers			
	3.1	NOT USED			
	3.2	Laser jet colour printer (A4 size)	Nos.	1	
	4.0	Software			
9.00.00		Software for DDCMIS meeting requirements specified under item "SYSTEM SOFTWARE REQUIREMENTS", sub section DDCMIS, Part-B, Section-VI of Technical Specifications.		As required basis	
10.00.00	<p>24 V DC POWER SUPPLY SYSTEM</p> <p>24 V DC Power Supply systems shall be of continuous duty for the following estimated loads:-</p>				

CLAUSE NO.

SCOPE OF SUPPLY & SERVICES



Description of Loads	Contractor's load	Power supply Configuration	Employer's load	Total Rating (Amp)	Quantity	
					per unit	Common
<p>1. UNIT TG C&I :- 24 V DC for all Contractor's load including</p> <p>a. TG-C&I system (see notes below);</p> <p>b. Any other load of Contractor or supplied system/equipment requiring 24 V DC supply</p>	*	1. As per cl 1.03.00(A), Subsection- IIC-05			2 sets	
2. Hydrogen Generation Plant (see notes below)		2. As per cl 1.03.00(D), Subsection- IIC-05				1 set
3. CPU Remote I/O panels(For common Regeneration area)	*	3. As per cl 1.03.00(B), Subsection- IIC-05				2 sets

The rating marked “*” are for instrument/equipment/system being supplied by Contractor. The Bidder shall estimate the requirement of these and provide additional capacity margin of 5% of the estimated Contractor's load for all the

CLAUSE NO.	SCOPE OF SUPPLY & SERVICES																																									
<p>11.00.00</p> <p>11.01.00</p> <p>11.02.00</p>	<p>items and thereafter add the Employer's loads to get the load for the entire system.</p> <p>Note:-</p> <ol style="list-style-type: none"> Control system would cover as a minimum, controllers, I/Os, associated modules etc. as well as, data communication system & Network devices (like LAN Switches), related to control system associated relays and solenoid valves driven by 24 V DC system, etc;. Any other loads of Contractor requiring 24 V DC supply shall also be included in this calculation. One set of manual discharge resistance bank of adequate capacity shall be Provided Per unit for the main plant 24VDC TG(C&I) control system. <p>UPS</p> <p>Uninterrupted Power Supply of required capacity shall be provided by Contractor for HMI and other relevant equipment of Hydrogen Generation Plant and CPU System</p> <p>Employer shall provide following single phase, 230 V AC UPS feeders for powering various Main Plant TG loads under the scope of this work through PDBs with redundant inputs from both ACDBs. Further distribution from ACDB downwards including the PDB's shall be in the scope of Bidder.</p> <table border="1" data-bbox="419 1189 1430 1704"> <thead> <tr> <th>Sl. no</th> <th>Fdr no.</th> <th>Frm</th> <th>To</th> <th>Feeder Desc.</th> <th>KVA</th> <th>PDB location</th> <th>PDB scope</th> </tr> </thead> <tbody> <tr> <td>1</td> <td>Fdr-1</td> <td>ACDB-1</td> <td>PDB-110-1</td> <td>HMI Load-1</td> <td>6</td> <td>Prog. Room</td> <td>TG vendor</td> </tr> <tr> <td>2</td> <td>Fdr-2</td> <td>ACDB-1</td> <td>PDB-110-1</td> <td>HMI Load-2</td> <td>6</td> <td>Prog. Room</td> <td>TG vendor</td> </tr> <tr> <td>3</td> <td>Fdr-3</td> <td>ACDB-1</td> <td>PDB-110-2</td> <td>TSI & other Loads</td> <td>3</td> <td>CER</td> <td>TG vendor</td> </tr> <tr> <td>4</td> <td>Fdr-4</td> <td>ACDB-1</td> <td>PDB-110-3</td> <td>Miscellaneous Loads</td> <td>5</td> <td>8.5m</td> <td>TG vendor</td> </tr> </tbody> </table> <p>Notes:</p> <p>(1) Feeders from ACDB-1 are only indicated above. Identical feeders for each PDB shall be provided from ACDB-2.</p>	Sl. no	Fdr no.	Frm	To	Feeder Desc.	KVA	PDB location	PDB scope	1	Fdr-1	ACDB-1	PDB-110-1	HMI Load-1	6	Prog. Room	TG vendor	2	Fdr-2	ACDB-1	PDB-110-1	HMI Load-2	6	Prog. Room	TG vendor	3	Fdr-3	ACDB-1	PDB-110-2	TSI & other Loads	3	CER	TG vendor	4	Fdr-4	ACDB-1	PDB-110-3	Miscellaneous Loads	5	8.5m	TG vendor	
Sl. no	Fdr no.	Frm	To	Feeder Desc.	KVA	PDB location	PDB scope																																			
1	Fdr-1	ACDB-1	PDB-110-1	HMI Load-1	6	Prog. Room	TG vendor																																			
2	Fdr-2	ACDB-1	PDB-110-1	HMI Load-2	6	Prog. Room	TG vendor																																			
3	Fdr-3	ACDB-1	PDB-110-2	TSI & other Loads	3	CER	TG vendor																																			
4	Fdr-4	ACDB-1	PDB-110-3	Miscellaneous Loads	5	8.5m	TG vendor																																			

CLAUSE NO.	SCOPE OF SUPPLY & SERVICES																	
	(2) Above indicated UPS feeders shall be provided from Employer's ACDB. (3) PDBs along with the necessary change over circuits (as applicable) along with further distribution to the load shall be in the scope of the contractor. (4) Half of the HMI Loads are to be powered through Feeder-1 and remaining half through Feeder-2 to ensure availability of at least 50% of the HMI Loads in event of any fault in either of the feeders.																	
12.00.00	PROCESS CONNECTION AND PIPING																	
12.01.00	The Contractor shall provide, install and test all required material which is necessary for proper installation and interconnection of the equipment/systems furnished by the Contractor as per this specification and their integration with Employer's main equipment/systems as per Technical Specification requirements and its sub-clauses, enclosed installation drawings and other applicable clauses on as required basis. The Contractor shall furnish, within his quoted lump sum price, all hardware and accessories to ensure that the equipment/systems furnished against this specification form a complete and operational system meeting the intent and requirement of this specification.																	
12.02.00	The Bidder shall note that no price adjustments shall be applicable for the equipment and services furnished as per this sub-section since the Contractor has to furnish these equipment/services on as required basis.																	
12.03.00	Local Instrument Enclosures (LIEs) and Local Instrument Racks (LIRs) a) Local Instrument Enclosures (LIEs) complete with all fittings, mountings & accessories etc for each unit on as required basis. b) Local Instrument Racks (LIRs) complete with all fittings, mountings & accessories etc. for each unit on as required basis.																	
13.00.00	THE FOLLOWING CONTRACT QUANTITIES OF EQUIPMENTS FOR LOCAL OPERATION SHALL BE FURNISHED FOR THE FOLLOWING SYSTEMS. <table border="1" data-bbox="418 1527 1420 1854"> <thead> <tr> <th data-bbox="418 1527 507 1630">SI No.</th> <th data-bbox="507 1527 810 1630">Item Description</th> <th colspan="2" data-bbox="810 1527 1114 1630">Qty</th> <th data-bbox="1114 1527 1420 1630">Application and location</th> </tr> <tr> <td data-bbox="418 1630 507 1702"></td> <td data-bbox="507 1630 810 1702"></td> <td data-bbox="810 1630 965 1702">Unit</td> <td data-bbox="965 1630 1114 1702">Common</td> <td data-bbox="1114 1630 1420 1702"></td> </tr> </thead> <tbody> <tr> <td data-bbox="418 1702 507 1854">1.</td> <td data-bbox="507 1702 810 1854">Operator Work stations</td> <td data-bbox="810 1702 965 1854"></td> <td data-bbox="965 1702 1114 1854">As per PLC configuration</td> <td data-bbox="1114 1702 1420 1854">At Hydrogen Generation Plant Control room</td> </tr> </tbody> </table>			SI No.	Item Description	Qty		Application and location			Unit	Common		1.	Operator Work stations		As per PLC configuration	At Hydrogen Generation Plant Control room
SI No.	Item Description	Qty		Application and location														
		Unit	Common															
1.	Operator Work stations		As per PLC configuration	At Hydrogen Generation Plant Control room														

CLAUSE NO.

SCOPE OF SUPPLY & SERVICES



			drawing	
2.	Operator Work stations	1 No	CPU regeneration control room	Operator Work stations
3.	Graphical Interface unit of 10"	1 no/unit plus +2 nos for common regeneration area	CPU service vessel remote I/O room+ CPU regeneration local control area	Graphical Interface unit of 10"

14.00.00

15.00.00

ONE SET OF RELATED FURNITURE, AS DEFINED BELOW :

SI No.	Area	Item description	Qty (unit)	Qty (Common)
1.	Hydrogen Generation Plant	a. Chair		2 nos
		b. Key pad		1 nos
		c. Locker set		1 nos
2.	CPU Remote I/O Room(Regeneration)	a. Chair		2 nos
		b. Key pad		1 nos
		c. Locker set		1 nos
3.	CPU Remote I/O Room(service vessel)	a. Chair	1 nos	
		b. Key pad	1 nos	
		c. Locker set	1 nos	

CLAUSE NO.	SCOPE OF SUPPLY & SERVICES	
<p>16.00.00</p> <p>17.00.00</p>	<p>For the items like Measuring Instruments, Process Connection and piping, Control Valves and Actuators, Other TG C&I systems, and Instrumentation and Power supply cables, contract quantities shall be governed by corresponding Sub-sections in Part-B.</p>	



**TECHNICAL SPECIFICATION FOR
HYDROGEN GENERATION PLANT
2 X 800 MW NTPC GADERWARA STPP STAGE-I**

SPEC NO. PE-TS-394-168-A001

VOLUME-IIB

SECTION

REV.NO.0

DATE

SHEET

MEASURING INSTRUMENTS

MEASURING INSTRUMENTS	
1.00.00	MEASURING INSTRUMENTS
1.01.00	Measuring instruments/equipment and subsystems offered by the Bidder shall be from reputed experienced manufacturers of specified type and range of equipment, whose guaranteed and trouble free operation has been proven. Refer Sub-section Basic Design Criteria. Further, all instruments shall be of proven reliability, accuracy, and repeatability requiring a minimum of maintenance. They shall comply with the acceptable international standards and shall be subject to Employer's approval. All instrumentation equipment and accessories under this specification shall be furnished as per technical specifications, ranges, makes/numbers as approved by the Employer during detailed engineering.
1.02.00	Every panel-mounted instrument requiring power supply shall be provided with a pair of easily replaceable glass cartridge fuses of suitable rating. Every instrument shall be provided with a grounding terminal and shall be suitably connected to the panel grounding bus.
1.03.00	All local gauges as well as transmitters, sensors, and switches for parameters like pressure, temperature, level, flow etc. as required for the safe and efficient operation and maintenance as well as for operator and management information (including all computation) of equipment under the scope of specification shall be provided on as required basis within the quoted lump sum price. For bidding purpose, tentative minimum instruments have been indicated on the P&IDs. However, contractor shall supply any additional local gauges/switches/transmitters/sensors for reasons mentioned above without any additional cost to the Employer.
1.04.00	The necessary root valves, impulse piping, drain cocks, gauge-zeroing cocks, valve manifolds and all the other accessories required for mounting/erection of these local instruments shall be furnished, even if not specifically asked for, on as required basis. The contacts of equipment mounted instruments, sensors; switches etc. for external connection including spare contacts shall be wired out in flexible/rigid conduits, independently to suitably located common junction boxes. The proposal shall include the necessary cables, flexible conduits, junction boxes and accessories for the above purpose. Double root valves shall be provided for all pressure tapping where the pressure exceeds 40 Kg./sq.cm.
1.05.00	For all instruments envisaged for sea water applications they shall be provided with wetted parts made of Monel / Hastelloy C or any other material (if proven ness experience of the proposed material for such applications is established by contractor:
1.06.00	All instruments shall be provided with durable epoxy coating for housings and all exposed surfaces of the instruments.

2.00.00

SPECIFICATION FOR ELECTRONIC TRANSMITTER FOR PRESSURE, D.P., FLOW AND LEVEL

2.01.00

ELECTRONIC TRANSMITTERS		
Sl.No.	Features	Essential/Minimum Requirements
1.	Type of Transmitter	Microprocessor based 2 wire type, Hart protocol compatible.
2.	Accuracy	± 0.1% of calibrated span (minimum)
3.	Output signal range	4-20 mA DC (Analog) along with superimposed digital signal (based on HART protocol)
4.	Turn down ratio	10:1 for vacuum/very low pressure applications.
		30:1 for other applications.
5.	Stability	± 0.1% of calibrated span for six months for Ranges up to and including 70 Kg/cm ² .
		± 0.25% of calibrated span for six months for Ranges more than 70 Kg/cm ² (g).
6.	Zero and span drift	+/- 0.015% per deg.C at max span.
		+/-0.11% per deg.C at min. Span.
7.	Load impedance	500 ohm (min.)
8.	Housing	Weather proof as per IP-55 with durable corrosion resistant epoxy coating.
9.	Over Pressure	150% of max. Operating pressure
10.	Connection (Electrical)	Plug and socket type
11.	Process connection	1/2 inch NPT (F)
12.	Span and Zero	Continuous, tamper proof, Remote as well as adjustability manual from instrument with zero suppression and elevation facility.
13.	Accessories	-Diaphragm seal, pulsation dampeners, syphon etc. as required by service and operating condition.

		-2 valve manifold for absolute pressure transmitters (3-valve manifold for gauge/ vacuum pressure transmitters) and 5 valve manifold for DP/level/flow transmitters.
		-For hazardous area, explosions proof enclosure as described in NEC article 500.
14.	Diagnostics	Self Indicating feature
15.	Power supply	24V DC \pm 10%.
16.	Adjustment/calibration/maintenance	Centralised PC based system (In Station C&I Scope). In addition total two (2) no. of hand- held type universal calibrators per unit, compatible with HART protocol, shall be provided.
Notes		
In case it becomes necessary to use a DP transmitter for pressure measurement then a 3-valve manifold should be used in place of 2-valve manifold.		
LVDT type is not acceptable.		
Where the process fluids are corrosive, viscous, solid bearing or slurry type, diaphragm seals shall be provided. Parts below the diaphragm shall be removable for cleaning. The entire volume above the diaphragm shall be completely filled with an inert liquid suitable for the application.		
2.02.00	GUIDED WAVE RADAR TYPE LEVEL TRANSMITTER	
Guided wave radar type level transmitters shall be provided for level measurements of the vessel under vacuum or low pressure applications.		
	Type	Guided wave Radar
	Principle	TDR (Time domain reflectometry)
	Probe Type& Material	Coaxial, SS316/316L. If required, probe shall be suitable for overfill prevention.
	Signal o/p	4-20mA with HART signal suitable for overfill prevention.
	Display	Integral
	Power supply	24 VDC

Accuracy	5mm
Electromagnetic compatibility	Shall meet EN 61326-1 (1997) and AmdtA1, class A equipment/EN 50081-2 & EN 5008 1-2 & EN 50082-2
Mounting	External cage mounting

The transmitters shall be provided with IP-55 protection class with durable corrosion resistant coating.

The transmitters shall be able to provide digital signals super imposed on 4-20 mA signal as per HART protocol.

2.03.00

Ultrasonic Type level Transmitter

Sl.No.	Features	Essential/Minimum requirement
1.	Type of Transmitter	Non contact Microprocessor based 2 wire type, HART protocol compatible Ultrasonic transmitter
2.	Output signal	Galvanically isolated 4-20mA DC (Analog) along with superimposed digital signal (based on HART protocol)
3.	Sensor Accuracy	+/- 0.5% of calibrated span.
4.	Sensor Repeatability	3mm or better
5.	Power supply	24 V DC +/-10%
6.	Temperature compensation	To be provided within transducer
7.	Configuration	Sensor unit and Electronic units are to be separate. It shall be possible to mount the Electronic unit at a remote accessible location from the transducer. All cables and weather proof fittings to interconnect transducer to electronic unit shall be provided by Bidder.
8.	Housing	Weather proof as per IP-55 with durable corrosion resistant coating.
9.	Calibration	Through HART Communicator.

Sl.No.	Features	Essential/Minimum requirement
10.	Zero and Span adjustment	Continuous, tamper proof, remote as well as manual adjustability from instrument. It shall be possible to calibrate the instrument without any level in the tank/sump etc.
11.	Sensor Material	Corrosion resistant material to suit individual application requirement.
12.	False signal tolerance	Transmitter shall be capable of ignoring false echoes from internal tank/sumps obstructions such as pipes, heating coils or agitator blades. Also transmitter shall have adjustable damping circuitry
13.	Range	Range of transmitter shall be capable of covering the complete level span of tank taking care of blocking distance, frequency attenuation due to surface, obstructions, vapors etc.
14.	Display	Minimum 4 character LCD display with integral keypad, access protected by user code
15.	Diagnostics	Loss of echo alarm etc.
16.	Load Impedance	500 ohms minimum
17.	Electrical Connection	Plug and socket
18.	Accessories	All weather canopy for protection from direct sunlight and direct rain. All mounting hardware and accessories required for erection and commissioning mounting fittings material shall be Ss 316. For hazardous areas, explosion proof enclosure as described in NEC article 500
Note:	Contractor can also provide Radar type transmitter in place of ultrasonic transmitters subject to approval by Employer during detailed engineering.	

3.00.00	TEMPERATURE ELEMENTS																													
3.01.00	Thermocouple																													
	<table border="1"> <thead> <tr> <th data-bbox="407 300 521 394">Sr. No.</th> <th data-bbox="521 300 894 394">Features</th> <th data-bbox="894 300 1471 394">Essential/Minimum Requirements</th> </tr> </thead> <tbody> <tr> <td data-bbox="407 394 521 552">1</td> <td data-bbox="521 394 894 552">Type of Thermocouple.</td> <td data-bbox="894 394 1471 552">: 16 AWG wire of Chromel-Alumel (Type K) or 24 AWG wire Pt-Rhodium Pt (Type R) depending on operating temperature Range (ungrounded type).</td> </tr> <tr> <td data-bbox="407 552 521 615">2</td> <td data-bbox="521 552 894 615">No. of element</td> <td data-bbox="894 552 1471 615">: Duplex</td> </tr> <tr> <td data-bbox="407 615 521 741">3</td> <td data-bbox="521 615 894 741">Housing/Head</td> <td data-bbox="894 615 1471 741">: IP-55/Diecast Aluminium. Plug in connectors are to be provided for external signal cable connection.</td> </tr> <tr> <td data-bbox="407 741 521 835">4</td> <td data-bbox="521 741 894 835">Sheathing of Thermocouple</td> <td data-bbox="894 741 1471 835">: Swaged type magnesium oxide insulation.</td> </tr> <tr> <td data-bbox="407 835 521 930">5</td> <td data-bbox="521 835 894 930">Calibration and accuracy</td> <td data-bbox="894 835 1471 930">: As per IEC-751/ANSI-C-96.1(special class)for T/C.</td> </tr> <tr> <td data-bbox="407 930 521 1024">6</td> <td data-bbox="521 930 894 1024">Characteristic</td> <td data-bbox="894 930 1471 1024">: Linear with respect to temp, within $\pm 1/2$ percent of top range value.</td> </tr> <tr> <td data-bbox="407 1024 521 1150">7</td> <td data-bbox="521 1024 894 1150">Accessories</td> <td data-bbox="894 1024 1471 1150">: Thermo well (as specified below) and shall be spring loaded for positive contacts with the well.</td> </tr> <tr> <td data-bbox="407 1150 521 1249">8</td> <td data-bbox="521 1150 894 1249">Standard</td> <td data-bbox="894 1150 1471 1249">: ANSI C 96.1 for Thermocouple and ASME PTC-19.3 for Thermo-well.</td> </tr> </tbody> </table>			Sr. No.	Features	Essential/Minimum Requirements	1	Type of Thermocouple.	: 16 AWG wire of Chromel-Alumel (Type K) or 24 AWG wire Pt-Rhodium Pt (Type R) depending on operating temperature Range (ungrounded type).	2	No. of element	: Duplex	3	Housing/Head	: IP-55/Diecast Aluminium. Plug in connectors are to be provided for external signal cable connection.	4	Sheathing of Thermocouple	: Swaged type magnesium oxide insulation.	5	Calibration and accuracy	: As per IEC-751/ANSI-C-96.1(special class)for T/C.	6	Characteristic	: Linear with respect to temp, within $\pm 1/2$ percent of top range value.	7	Accessories	: Thermo well (as specified below) and shall be spring loaded for positive contacts with the well.	8	Standard	: ANSI C 96.1 for Thermocouple and ASME PTC-19.3 for Thermo-well.
Sr. No.	Features	Essential/Minimum Requirements																												
1	Type of Thermocouple.	: 16 AWG wire of Chromel-Alumel (Type K) or 24 AWG wire Pt-Rhodium Pt (Type R) depending on operating temperature Range (ungrounded type).																												
2	No. of element	: Duplex																												
3	Housing/Head	: IP-55/Diecast Aluminium. Plug in connectors are to be provided for external signal cable connection.																												
4	Sheathing of Thermocouple	: Swaged type magnesium oxide insulation.																												
5	Calibration and accuracy	: As per IEC-751/ANSI-C-96.1(special class)for T/C.																												
6	Characteristic	: Linear with respect to temp, within $\pm 1/2$ percent of top range value.																												
7	Accessories	: Thermo well (as specified below) and shall be spring loaded for positive contacts with the well.																												
8	Standard	: ANSI C 96.1 for Thermocouple and ASME PTC-19.3 for Thermo-well.																												
3.02.00	Resistance Temperature Detector (RTD)																													
	<table border="1"> <thead> <tr> <th data-bbox="407 1822 521 1942">Sr. No.</th> <th data-bbox="521 1822 894 1942">Features</th> <th data-bbox="894 1822 1471 1942">Essential/Minimum Requirements</th> </tr> </thead> <tbody> <tr> <td data-bbox="407 1942 521 2032">1</td> <td data-bbox="521 1942 894 2032">Type of RTD.</td> <td data-bbox="894 1942 1471 2032">: Four wire, Pt-100 (100 Ohms resistance at zero degree Centigrade).</td> </tr> <tr> <td data-bbox="407 2032 521 2095">2</td> <td data-bbox="521 2032 894 2095">No. of element</td> <td data-bbox="894 2032 1471 2095">: Duplex</td> </tr> <tr> <td data-bbox="407 2095 521 2100">3</td> <td data-bbox="521 2095 894 2100">Housing/Head</td> <td data-bbox="894 2095 1471 2100">: IP-55/Diecast Aluminium. Plug in connectors are to be provided for external signal cable connection.</td> </tr> <tr> <td data-bbox="407 2100 521 2100">4</td> <td data-bbox="521 2100 894 2100">Sheathing of RTD</td> <td data-bbox="894 2100 1471 2100">: Metal sheathed, ceramic packed</td> </tr> </tbody> </table>			Sr. No.	Features	Essential/Minimum Requirements	1	Type of RTD.	: Four wire, Pt-100 (100 Ohms resistance at zero degree Centigrade).	2	No. of element	: Duplex	3	Housing/Head	: IP-55/Diecast Aluminium. Plug in connectors are to be provided for external signal cable connection.	4	Sheathing of RTD	: Metal sheathed, ceramic packed												
Sr. No.	Features	Essential/Minimum Requirements																												
1	Type of RTD.	: Four wire, Pt-100 (100 Ohms resistance at zero degree Centigrade).																												
2	No. of element	: Duplex																												
3	Housing/Head	: IP-55/Diecast Aluminium. Plug in connectors are to be provided for external signal cable connection.																												
4	Sheathing of RTD	: Metal sheathed, ceramic packed																												

3.03.00	5	Calibration and accuracy	:	As per DIN-43760 Class-A for RTD	
	6	Characteristic	:	Linear with respect to temp, within $\pm 1/2$ percent of top range value.	
	7	Accessories	:	Thermo well (as specified below) and shall be spring loaded for positive contacts with the well.	
	8	Standard	:	DIN-43760 for RTD and ASME PTC-19.3 for Thermo-well.	
	Metal Temperature Thermocouples				
	Measuring Medium	Metal Temperature			
	Material of Thermocouple.	Chromel Alumel Type K			
	Type of Thermocouple	Duplex with separate hot junctions, ungrounded			
	Insulation	Mineral Insulation Magnesium Oxide.			
	Thermocouple wire gauge	16 AWG			
	Protective sheath	SS 321			
	Protective sheath dia	8 mm O.D			
Characteristics of Thermocouple	Special limits of error as in ANSI thermocouple MC 96.01.1975				
Mounting accessories	1/2" BSP SS sliding end connector, weld pad, clamps of heat resistant steel SS310.				
Cold end sealing	SS pot weal with colour coded PTFE headed sleeve Insulated flexible tails. Sealing compound- Epoxy resin.				
Minimum bending radius	30 mm				
Length of T/C	30 Mtr. (minimum)				

<p>3.04.00</p>	<p>Thermo well (for all process temp. elements)</p> <ul style="list-style-type: none"> (a) Shall be one piece solid bored type of 315 SS of step-less tapered design. (As per ASME PTC 19.3 1974) (b) For Mill classifier outlet long life solid sintered tungsten carbide material of high abrasion resistance shall be provided. (c) For Air & Flue gas 316 SS protecting tube with welded cap. (However contractor shall provide better material for Flue gas service if require based on the specify boiler design parameters). (d) For furnace zone, impervious ceramic protecting tube of suitable material along with Incoloy supporting tubes and adjustable flanges.
<p>4.00.00</p>	<p>TEMPERATURE TRANSMITTER</p> <p>Following types of 2-wire temperature transmitter (directly powered from 4-20mA input cards of DDCMIS) shall be provided. The temperature transmitter shall be fully compatible with thermocouples and RTDs being provided by the contractor. Temperature compensation of the thermocouples shall be performed in the temperature transmitter itself.</p> <ul style="list-style-type: none"> a. Single Input Head mounted Temperature Transmitter <ul style="list-style-type: none"> These shall be suitable for mounting in the head of temperature element itself. The protection class of head of thermo well along with its plug-in connector shall be min. IP65. b. Single Input DIN-rail mounted Temperature Transmitter <ul style="list-style-type: none"> These shall be suitable for mounting on DIN-rails in JB's. The specifications of the JB's shall be same as indicated in Subsection INST CABLE with additional DIN-rails and IP 65 Protection class. This temperature transmitter shall be the ones which are especially designed for DIN-rail mounting with IP 20 protection class. These shall have terminals for input/output provided on front side when mounted on DIN-rail. Head mounted temperature transmitter with clamps to make it suitable for DIN-rail mounting shall not be acceptable under this category. c. Dual-input Temperature Transmitter With Indicator: <ul style="list-style-type: none"> These shall be suitable for mounting on pipes/ support. Both elements of the duplex thermocouple/RTD shall be wired to a single transmitter. Indicator shall be provided with these transmitters. These transmitters shall have bump less change over facility to second sensor in case first sensor fails. This change-over is to be alarmed. Protection class shall be IP65 minimum.

d. Common requirements for each of the above type of temperature transmitters			
Output	:	2-wire (power supply from input card of Control System) with 4-20mA output with superimposed HART protocol signal.	
Input	:	Same transmitter shall be capable to handle Pt-100 RTD , Thermocouples –K&R types (input type to be selectable at site through HART terminal)	
Isolation	:	min. 500 V AC	
EMC compatibility	:	as per EN 61326	
Operating ambient temperature	:	0 to 85 deg C (without indicator)	
		0 to 70 deg C (with indicator)	
Power supply		compatible with input module of Control System	
Accessories		Mounting arrangements including clamps etc.	
Composite Accuracy	(a)	For head mounted and DIN-rail mounted types:	
(Refer note 2)		RTD	=<0.4% of 0-250 deg C span
		T/C-K type	=<0.4% of 0-600 deg C span
		T/C-R type	=<0.4% of 0-1000 deg C span
		CJC accuracy (for thermocouples) shall be =< 1 deg C	
	(b)	For dual-input type:	
		RTD	=<0.25% of 0-250 deg C span
		T/C-K type	=<0.2% of 0-600 deg C span
		CJC accuracy (for thermocouples) shall be =< 1 deg C	
Notes:-			
1. In case of failure (open or burn-out) of RTD/thermocouple, temp. transmitter shall provide low temperature output.			

2. Composite Accuracy is to be calculated as summation of all applicable accuracies of temp transmitter, for converting sensor input to output in 4-20 mA (e.g., basic accuracy, digital accuracy, D/A accuracy, etc.) and temperature effect on these accuracies at ambient temperature of 50 deg C, based on the figure/ formula given in the standard product catalogue for span as specified above for various types of Temperature Elements specified. All such accuracy/ temp effect figures in catalogue shall be first converted to deg C, and then percentage of this converted accuracy in specified span shall be calculated to compare with the specified composite accuracy figures.

e. Field bus compatible temperature Transmitters

Temperature transmitters of this category shall be field mounting type & shall be capable of withstanding operating ambient temperature upto 85 deg C. These modules shall be connected to DDCMIS through field bus such as Profibus, Foundation Field bus etc directly from the transmitter. Maximum Number of inputs per such temperature transmitter shall be eight. These shall be mounted in cabinets in non-AC areas.

As an alternate, these signals from temperature transmitters can be connected to DDCMIS through standard remote I/O modules of the DCS, in which case, the temperature transmitter signals will be acquired through 4-20mA input modules in the remote I/O cabinet for connecting to DDCMIS through remote I/O bus.

Air conditioned panel shall be provided for remote I/O.

5.00.00

ANALYSER INSTRUMENTS:

Common Requirements		
1	Output signals Analog	4-20 mA DC
	Binary	2 NO + 2 NC for high alarm
2.	Zero & span Adjustment	Available
3.	Ambient temp.	50°C
4.	Indication	Digital
5.	Enclosure Type/Material	Weather & Dust proof (IP 55) Die cast Aluminium/SS
6.	Type of Electronics	Microprocessor based
7.	Digital Signal transmission	RS 232 Link & to suit connections protocol to DDCMIS

5.01.00	8.	Calibration	Auto & Manual (from Remote)
	9.	Error Diagnostic	To be provided
	10.	Others	If analyser provides superimposed HART signal on 4-20 mA DC output, It shall also be connected to PC based station (In Employer's Scope).
	Hydrogen Analyser		
	1.	Output signals:	Analog 4-20 mA DC
	2.	Zero & span Adjustment	Available
	3.	Ambient temp.	50°C
	4.	Indication	Digital
	5.	Enclosure Type/Material	Weather & Dust proof (IP 55) Die cast Aluminum/SS
	6.	Type of Electronics	Microprocessor based with self diagnostic facility
	7.	Digital Signal transmission protocol	RS 232 Link & to suit connections to Control System
5.02.00	8.	Calibration	Auto & Manual (from Remote)
	9.	Error Diagnostic	To be provided
	10.	Repeatability	± 1% of calibrated span
	11.	Linearity	± 2% of calibrated span
	PH Analyser		
	1.	TYPE	CELL - FLOW THROUGH
	2.	ACCURACY	< ± 1% OF SPAN
	3.	RANGE	0 - 14 PH, PROGRAMMABLE
	4.	NO. OF STEAMS	SINGLE
	5.	STABILITY	< 0.001 PH / WEEK
	6.	TEMP. COEFFICIENT / TEMP. ERROR	0.001 PH / DEG. C

	7. TYPE OF ELECTRONICS	MICROPROCESSOR BASED WITH SELF-DIAGNOSTIC FACILITY.
	8. INDICATION	DIGITAL
	9. ENCLOSURE	WEATHER DUST PROOF (IP55) DIE CAST ALUMINUM.
6.00.00	SPECIFICATION FOR FLOW ELEMENTS	
6.01.00	Orifice Plate	
	Features	Essential/Minimum Requirements
	Type	Concentric as per ASME PTC-19.5 (Part-II), ISA RP-3.2, 1960 or BS-1042
	Material	316 SS
	Thickness	3 mm for main pipe diameter up to 300 mm and 6 mm for main pipe dia above 300 mm.
	Material of branch pipe	Same as main pipe
	Root valve type	Globe
	Root valve material	316 SS
	Root valve size	1 inch
	Impulse pipe of same material up to root valve	Required
	Tappings	Flanged weld neck. 3 pairs. of tapping.
	Beta Ratio	0.34 to 0.7
	Beta Ratio calculation to be submitted	Yes
	Assembly drg. and flow Vs DP Curves	Yes
	Accessories	Root valves, flanges, Vent/drain hole(As required)

<p>6.02.00</p>	<p>Contractor shall submit certified flow calculation and differential pressure vs. flow curves for each element for Employer's approval. Sizing calculation, precise flow calculation for all the flow elements, fabrication and assembly drawings and installation drawings shall be submitted for Employer's approval. One Flow element of each type shall be calibrated in the test laboratory for validation of commutated flow calculations.</p> <p>Flow Nozzle</p> <table border="1" data-bbox="407 478 1471 1444"> <thead> <tr> <th data-bbox="407 478 914 541">Features</th> <th data-bbox="914 478 1471 541">Essential/Minimum Requirements</th> </tr> </thead> <tbody> <tr> <td data-bbox="407 541 914 636">Type</td> <td data-bbox="914 541 1471 636">Long radius, welded type as per ASME PTC-19.5 (Part-III) or BS-1042</td> </tr> <tr> <td data-bbox="407 636 914 699">Material</td> <td data-bbox="914 636 1471 699">316 SS</td> </tr> <tr> <td data-bbox="407 699 914 762">Thickness</td> <td data-bbox="914 699 1471 762">Suitable for intended application.</td> </tr> <tr> <td data-bbox="407 762 914 825">Material of branch pipe</td> <td data-bbox="914 762 1471 825">Same as main pipe</td> </tr> <tr> <td data-bbox="407 825 914 888">Root valve type</td> <td data-bbox="914 825 1471 888">Globe</td> </tr> <tr> <td data-bbox="407 888 914 951">Root valve material</td> <td data-bbox="914 888 1471 951">316 SS</td> </tr> <tr> <td data-bbox="407 951 914 1014">Root valve size</td> <td data-bbox="914 951 1471 1014">1 inch</td> </tr> <tr> <td data-bbox="407 1014 914 1108">Impulse pipe of same material up to root valve</td> <td data-bbox="914 1014 1471 1108">Required</td> </tr> <tr> <td data-bbox="407 1108 914 1171">Tapping</td> <td data-bbox="914 1108 1471 1171">D and D/2 (3 sets of tapings points)</td> </tr> <tr> <td data-bbox="407 1171 914 1234">Beta Ratio</td> <td data-bbox="914 1171 1471 1234">Around 0.7</td> </tr> <tr> <td data-bbox="407 1234 914 1318">Beta Ratio calculation to be submitted</td> <td data-bbox="914 1234 1471 1318">Yes</td> </tr> <tr> <td data-bbox="407 1318 914 1381">Assembly drg. and flow Vs DP Curves</td> <td data-bbox="914 1318 1471 1381">Yes</td> </tr> <tr> <td data-bbox="407 1381 914 1444">Accessories</td> <td data-bbox="914 1381 1471 1444">Root valves, vent and drain hole.</td> </tr> </tbody> </table> <p>Contractor shall submit certified flow calculation and differential pressure vs. flow curves for each element for Employer's approval. Sizing calculation, precise flow calculation for all the flow elements, fabrication and assembly drawings and installation drawings shall be submitted for Employer's approval. One Flow element of each type shall be calibrated in the test laboratory for validation of computed flow calculations.</p>		Features	Essential/Minimum Requirements	Type	Long radius, welded type as per ASME PTC-19.5 (Part-III) or BS-1042	Material	316 SS	Thickness	Suitable for intended application.	Material of branch pipe	Same as main pipe	Root valve type	Globe	Root valve material	316 SS	Root valve size	1 inch	Impulse pipe of same material up to root valve	Required	Tapping	D and D/2 (3 sets of tapings points)	Beta Ratio	Around 0.7	Beta Ratio calculation to be submitted	Yes	Assembly drg. and flow Vs DP Curves	Yes	Accessories	Root valves, vent and drain hole.
	Features	Essential/Minimum Requirements																												
	Type	Long radius, welded type as per ASME PTC-19.5 (Part-III) or BS-1042																												
	Material	316 SS																												
	Thickness	Suitable for intended application.																												
	Material of branch pipe	Same as main pipe																												
	Root valve type	Globe																												
	Root valve material	316 SS																												
	Root valve size	1 inch																												
	Impulse pipe of same material up to root valve	Required																												
	Tapping	D and D/2 (3 sets of tapings points)																												
	Beta Ratio	Around 0.7																												
	Beta Ratio calculation to be submitted	Yes																												
	Assembly drg. and flow Vs DP Curves	Yes																												
Accessories	Root valves, vent and drain hole.																													

7.00.00

SPECIFICATIONS FOR PR. GAUGE, D.P. GAUGE, TEMP. GAUGE AND LEVEL GAUGE.

SI. No	FEATURES	ESSENTIAL/MINIMUM REQUIREMENTS		
		Pr. Gauge/ DP Gauge/ Draught gauges	Temperature Gauge	Level Gauge
1	Sensing Element and material	Bourdon for high pressure, Diaphragm/ Bellow for low pr. Of 316 SS	Mercury in steel for below 450°C and inert gas actuated for above 450°C of SS bulb and capillary.	Tempered * toughened Borosilicate gauge glass steel armoured reflex or transparent type.
2	Body material	Die-cast aluminium	Die-cast aluminium	Forged carbon steel/304 SS
3	Dial size	150mm	150 mm	Tubular covering entire range
4	End connection	1/2 inch NPT (M)	3/4" NPT (M)	Process connection as per ASME PTC and drain/vent 15 NB
5	Accuracy	±1% of span	± 1% of span	± 2%
6	Scale	Linear, 270° arc graduated in metric units	Linear, 270° arc graduated in °C	Linear vertical
7	Range selection	Cover 125% of max. of scale	Cover 125% of max. of scale	Cover 125% of max. of scale
8	Over range test	Test pr. for the assembly shall be 1.5 to the max. Design pr. at 38°C.		
9	Housing	Weather and dust proof as per IP-55	Weather and dust proof as per IP-55	CS/304 SS leak proof
10	Zero/span adjustment	Provided	Provided	--
11	Identification	Engraved with service legend or laminated phenolic name plate		

8.00.00	12	Accessories	Blow out disc, siphon, snubber, pulsation dampener, chemical seal (if required by process) gauge isolation valve	SS Thermowell	Gasket for all KEL-F shield for transparent type vent and drain valves of Steel/SS as per CS/Alloy process Requirement.	
	13	Material of Bourdon/movement	316 SS / 304 SS	316 SS / 304 SS		
	Notes:-					
	*Bicolour type level gauges will be provided for applications involving steam and water except for condensate and feed water services.					
	Length of gauge glass shall not be more than 1400 mm. If the vessel is higher, multiple gauge glasses with 50 mm overlapping shall be provided.					
	Where the process fluids are corrosive, viscous, solid bearing or slurry type, diaphragm seals shall be provided. Parts below the diaphragm shall be removable for cleaning. The entire volume above the diaphragm shall be completely filled with an inert liquid suitable for the application.					
	ROTAMETERS					
	SR. NO.	FEATURES	ESSENTIAL / MINIMUM REQUIREMENTS			
	1.	TYPE	VARIABLE AREA METAL TUBE			
	2.	FLUID MEDIA	WATER/OIL			
3.	TUBE BODY	SS316				
4.	MATERIAL OF FLOAT	316 SS				
5.	INDICATOR	LINEAR SCALE				
6.	ACCESSORIES	FLANGE, ORIFICE IN CASE OF BYPASS ROTAMETER (FOR LINE SIZE ABOVE 100 MM)				
7.	HOUSING PROTECTION CLASS	IP-55				

9.00.00	8.	ACCURACY	± 2% OF MEASURED VALUE.		
	PROCESS ACTUATED SWITCHES				
	FEATURES		ESSENTIAL / MINIMUM REQUIREMENTS		
		Pressure/ Draft Switches/ DP Switches	Temperature switches	Level switches	
	Sensing Element	Piston actuated for high pressure and diaphragm or bellows for low pr./ vacuum	Vapor pressure sensing, liquid filled bellow type with SS bulb and capillary (10 m minimum)	Capacitance types for oil and dirty medium, water, condensate application.	
				Float type switches for applications as decided by Employer during detailed engineering.	
				Capacitance/ Conductivity/ Ultrasonic type for acid and alkali application.	
				Radio-frequency/ Ultrasonic type for ash hopper, ash slurry application.	
	Material	316 SS	Bulb 316 SS/ capillary 304 SS	316 SS	
	End connection	½ inch NPT (F)	½ inch NPT (F)	Manufacturer standard	
	Over range proof pressure	150% of max. design pr.	-	150% of max. design pressure	
Repeatability	± 0.5% of full range				
No. of contacts	2 No.+2NC. SPDT snap action dry contact				
Rating of contacts	60 V DC, 6 VA (or more if required by DDCMIS)				
Elect. Connection	Plug in socket.				

10.00.00	Set point/ dead band adjustment	Provided over full range.		
	Enclosure	Weather and dust proof as per IP-55		
	Accessories	Siphon, snubber, chemical seal, pulsation dampeners as required by process	Thermo well of 316 SS and packing glands	All mounting accessories
	Mounting	Suitable for enclosure/ rack mounting or direct mounting	Suitable for rack mounting or direct mounting	-
	Power Supply (wherever required)	24 V DC, to be arranged by Contractor except for Ash Level Switches, where the same shall be as per Contractor's Standard practice.		
	Where the process fluids are corrosive, viscous, solid bearing or slurry type, diaphragm seals shall be provided. Parts below the diaphragm shall be removable for cleaning. The entire volume above the diaphragm shall be completely filled with an inert liquid suitable for the application.			
DEW POINT METER				
Sensor				
Type	:	Capacitance type with change in output proportional to moisture present.		
Service	:	Dry Air		
Range	:	-50 to 0 Degree Centigrade Dew-Point		
Sensor Accuracy	:	Better than +/-0.5^		
Operating Temperature	:	0 to 50 degree C.		
Operating Pressure	:	0-10 Kg./Cm2, suitable for process application.		

Analyser		
Input	:	Change in capacitance from dew point sensor.
Display	:	Combined enclosure with two three-digit seven segments LED display with decimal point after two digits. LED height shall be 4 inches, clearly legible from a distance of atleast 10 meters.
Range	:	-50 to 0 Degree Centigrade Dew-Point
Display Accuracy	:	Better than ± 2 Degree C.
Mounting	:	Table top/Flush mounting, to be finalised during detailed engineering.
Power supply	:	240V AC, 50 Hz to be arranged by the contractor.
Output	:	5-20 mA DC capable of driving a load impedance of 500 ohms minimum.

4-20 mA DC Output signal is to be connected to control system in Contractor's Scope (Interconnection cables are to be provided by the Contractor).

In case the system is not suitable for Direct online mounting, then all the required sampling system is to be provided by the contractor.

All required accessories including cables, sensor holder, desiccant chambers, mounting fixtures etc. are to be supplied by the Contractor within his quoted lumpsum price.

CLAUSE NO.	<p style="text-align: center;">TECHNICAL REQUIREMENTS</p> 		
CONTROL VALVES, ACTUATORS & ACCESSORIES			
1.00.00	CONTROL VALVES, ACTUATORS & ACCESSORIES		
1.01.00	General Requirements		
1.01.01	The control valves and accessories equipment furnished by the Bidder shall be designed, constructed and tested in accordance with the latest applicable requirements of code for pressure piping ANSI B 31.1, the ASME Boiler & pressure vessel code, Indian Boiler Regulation (IBR), ISA, and other standards specified elsewhere as well as in accordance with all applicable requirements of the "Federal Occupational Safety and Health Standards, USA" or acceptable equal standards. All the Control Valves, their actuators and accessories to be furnished under this Sub-section will be fully suitable and compatible with the modulating loops covered under the Specification.		
1.01.02	All the control valves and accessories offered by the Bidder shall be from reputed, experienced manufacturers of specified type and range of valves.		
1.01.03	For special type of control valves such as combined pressure and temperature control valves for Aux PRDS application, separator drain control valves, refer to the corresponding mechanical sections.		
1.02.00	CONTROL VALVE SIZING & CONSTRUCTION		
1.02.01	The design of all valve bodies shall meet the specification requirements and shall conform to the requirements of ANSI (USA) for dimensions, material thickness and material specification for their respective pressure classes.		
1.02.02	The valve sizing shall be suitable for obtaining maximum flow conditions with valve opening at approximately 80% of total valve stem travel and minimum flow conditions with valve stem travel not less than 10% of total valve stem travel. All the valves shall be capable of handling at least 120% of the required maximum flow. Further, the valve stem travel range from minimum flow condition to maximum flow condition shall not be less than 50% of the total valve stem travel. The sizing shall be in accordance with the latest edition of ISA handbook on control valves. While deciding the size of valves, Bidder shall ensure that valves trim exit outlet velocity as defined in ISA handbook does not exceed 8 m/sec for liquid services, 150 m/sec. for steam services and 50% of sonic velocity for flashing services. Bidder shall furnish the sizing calculations clearly indicating the outlet velocity achieved with the valve size selected by him as well as noise calculations, which will be subject to Employer's approval during detailed engineering.		
1.02.03	Control valves for steam and water applications shall be designed to prevent cavitation, wire drawing, flashing on the downstream side of valve and down stream piping. Thus for cavitation/flashing service, only valve with anti cavitation trim shall be provided. Detailed calculations to establish whether cavitation will occur or not for any given application shall be furnished.		
1.02.04	Control valves for application such as SH Spray Control, RH spray Control, Heavy Oil Heating, pressurizing and Control system shall have permissible leakage rate as per leakage Class V. All other control valves shall have leakage rate as per leakage Class-IV.		
1.02.05	The control valve induced noise shall be limited to 85 dBA at 1 meter from the valve surface under actual operating conditions. The noise abatement shall be achieved by valve body and trim design and not by use of silencers.		

CLAUSE NO.	TECHNICAL REQUIREMENTS			
2.00.00	VALVE CONSTRUCTION			
2.01.00	All valves shall be of globe body design & straightaway pattern with single or double port, unless other wise specified or recommended by the manufacturer to be of angle body type. Rotary valve may alternatively be offered when pressure and pressure drops permit.			
2.02.00	Valves with high lift cage guided plugs & quick-change trims shall be supplied.			
2.03.00	Cast Iron valves are not acceptable.			
2.04.00	Bonnet joints for all control valves shall be of the flanged and bolted type or other construction acceptable to the Employer. Bonnet joints of the internal threaded or union type will not be acceptable.			
2.05.00	Plug shall be of one-piece construction cast, forged or machined from solid bar stock. Plug shall be screwed and pinned to valve stems or shall be integral with the valve stems.			
2.06.00	All valves connected to vacuum on down stream side shall be provided with packing suitable for vacuum applications (e.g. double vee type chevron packing)			
2.07.00	Valve characteristic shall match with the process characteristics.			
2.08.00	Extension bonnets shall be provided when the maximum temperature of flowing fluid is greater than 280 deg. C.			
2.09.00	Flanged valves shall be rated at no less then ANSI press class of 300 lbs.			
3.00.00	VALVE MATERIALS			
	Sr. No.	Service	Body material	Trim Material
	1	Non-corrosive, non-flashing and non-cavitation service except DM water	Carbon steel ASTM-A216 Gr. WCB for fluid temperature below 275 Deg. C Alloy steel ASTM-A217Gr. WC9 for fluid temperature above 275 Deg. C	316SS stellite with stellite faced guide posts and bushings.
	2.	Severe flashing/cavitation on services	Alloy steel ASTM-A217 Gr. WC9	440 C
	3.	Low flashing/cavitation on service	Alloy steel ASTM-A217 Gr. WC6	17-4 PH SS
	4.	DM water service	316 SS	316 SS
	NOTE Valve body rating shall meet the process pressure and temperature requirement as per ANSI B16.34.			
	However, Bidder may offer valves with body and trim materials better than specified materials and in such cases Bidder shall furnish the comparison of properties including cavitation resistance, hardness, tensile strength, strain energy, corrosion resistance and erosion resistance etc. of the offered material vis-a-vis the specified material for Employer's consideration and approval.			

CLAUSE NO.	TECHNICAL REQUIREMENTS																					
4.00.00	<p>END PREPARATION</p> <p>Valve body ends shall be either butt welded/socket welded, flanged (Rubber lined for condensate service) or screwed as finalized during detailed engineering and as per Employer's approval. The welded ends wherever required shall be butt welded type as per ANSI B 16.25 for control valves of sizes 65 mm and above. For valves size 50 mm and below welded ends shall be socket welded as per ANSI B 16.11. Flanged ends wherever required shall be of ANSI pressure-temperature class equal to or greater than that of the control valve body.</p>																					
5.00.00	<p>VALVE ACTUATORS</p> <p>All control valves shall be furnished with pneumatic actuators except for pressure and temperature control valve for auxiliary PRDS application (electro-hydraulic / pneumatically operated) and separator drain control valve (electro-hydraulic type). The Bidder shall be responsible for proper selection and sizing of valve actuators in accordance with the pressure drop and maximum shut off pressure and leakage class requirements. The valve actuators shall be capable of operating at 60 deg.C continuously.</p> <p>Valve actuators and stems shall be adequate to handle the unbalanced forces occurring under the specified flow conditions or the maximum differential pressure specified. An adequate allowance for stem force, at least 0.15 Kg/sq.cm. per linear millimeter of seating surface, shall be provided in the selection of the actuator to ensure tight seating unless otherwise specified.</p> <p>The travel time of the pneumatic actuators shall not exceed 10 seconds.</p>																					
6.00.00	<p>CONTROL VALVE ACCESSORY DEVICES</p>																					
6.01.00	<p>All pneumatic actuated control valve accessories such as air locks, hand wheels/hand-jacks, limit switches, microprocessor based electronic Positioner, diffusers, external volume chambers, position transmitters (capacitance or resistance type only), reversible pilot for Positioner, tubing and air sets, solenoid valves and junction boxes etc. shall be provided as per the requirements.</p>																					
7.00.00	<p>SPECIFICATIONS FOR MICROPROCESSOR BASED ELECTRONIC POSITIONER</p> <table border="1" data-bbox="389 1305 1382 1854"> <tbody> <tr> <td data-bbox="389 1305 456 1675" rowspan="4">1</td> <td data-bbox="456 1305 655 1675" rowspan="4">Electrical</td> <td data-bbox="655 1305 900 1391">a) Input Demand Signal</td> <td data-bbox="900 1305 1382 1391">4-20 mA</td> </tr> <tr> <td data-bbox="655 1391 900 1478">b) Power Supply</td> <td data-bbox="900 1391 1382 1478">Loop Powered from the output card of Control System.</td> </tr> <tr> <td data-bbox="655 1478 900 1597">c) HART Protocol</td> <td data-bbox="900 1478 1382 1597">Compatibility for Remote Calibration & Diagnostics (Super-imposed HART signal on input Signal (4-20 mA)</td> </tr> <tr> <td data-bbox="655 1597 900 1675">d. Valve position sensing</td> <td data-bbox="900 1597 1382 1675">Position sensing, 4-20 mA output signal to be provided for control system.</td> </tr> <tr> <td data-bbox="389 1675 456 1854" rowspan="3">2</td> <td data-bbox="456 1675 655 1854" rowspan="3">Environment</td> <td data-bbox="655 1675 900 1736">a) Operating temp.</td> <td data-bbox="900 1675 1382 1736">(-)30 To 80 Deg. C</td> </tr> <tr> <td data-bbox="655 1736 900 1796">b) Humidity</td> <td data-bbox="900 1736 1382 1796">0-95 %</td> </tr> <tr> <td data-bbox="655 1796 900 1854">c) Protection class</td> <td data-bbox="900 1796 1382 1854">IP-65 Minimum</td> </tr> </tbody> </table>			1	Electrical	a) Input Demand Signal	4-20 mA	b) Power Supply	Loop Powered from the output card of Control System.	c) HART Protocol	Compatibility for Remote Calibration & Diagnostics (Super-imposed HART signal on input Signal (4-20 mA)	d. Valve position sensing	Position sensing, 4-20 mA output signal to be provided for control system.	2	Environment	a) Operating temp.	(-)30 To 80 Deg. C	b) Humidity	0-95 %	c) Protection class	IP-65 Minimum	
1	Electrical	a) Input Demand Signal	4-20 mA																			
		b) Power Supply	Loop Powered from the output card of Control System.																			
		c) HART Protocol	Compatibility for Remote Calibration & Diagnostics (Super-imposed HART signal on input Signal (4-20 mA)																			
		d. Valve position sensing	Position sensing, 4-20 mA output signal to be provided for control system.																			
2	Environment	a) Operating temp.	(-)30 To 80 Deg. C																			
		b) Humidity	0-95 %																			
		c) Protection class	IP-65 Minimum																			
				i																		

CLAUSE NO.	TECHNICAL REQUIREMENTS				
	3	Software for Configuration and Diagnostics	Software	Windows based software. Software shall meet the requirements for Configuration, Diagnostics, Calibration and Testing of the actuator.	
			Diagnostic/Test features	Advanced diagnostic features like Stroke counter or Travel counter, Leakage in actuators, Valve Signature analysis, Step Response test, Valve friction /Jamming detection etc to be provided.	
	4	Test reports/ Certificates	Factory Valve Signature Tests Reports (Pr Vs Valve travel and Travel Vs I/P signal) are to be provided.		
			Test certificates as per Manufacture Standard/Relevant Standard are to be submitted.		
	5	Configuration/ Calibration.	Remote & Local Calibration, Auto & Manual Calibration shall be possible.		
	6	Operating Range	Full range/ Split range.		
	7	Modes	Valve Action	Direct / Reverse Valve Action	
			Flow Characterization	Possible to fit Valve Characteristic Curves- Linear , Equal percentage etc.	
	8	Fail Safe/Fail Freeze	Fail Safe/Fail Freeze feature is to be provided. (In case the fail freeze feature is not intrinsic to the positioner, Bidder shall achieve the same externally through solenoid valve connected in the pneumatic circuit).		
	9	Pneumatic	Air capacity	Sufficient to handle the valves & actuators selected/ Boosters to be supplied, if required.	
Air pressure			To suit the air supply pressure/quality available.		
Process connection			1/4" NPT		
10	Performance	Characteristic deviation	<=0.5 % of span.		
		Ambient temp effect	<=0.01 %/ deg C or better.		

CLAUSE NO.	TECHNICAL REQUIREMENTS			
	10	EMC & CE Compliance	Required to International Standard like EN/IEC.	EN50081-2 & EN50082 or equivalent.
	11	Accessories	In-built Operator Panel	Display with push buttons for configuration and display on the positioner itself (Password protected/Hardware lock).
			Hand Held Hart Calibrator	Universal Hart Calibrator to be provided (for quantity, refer <i>Part-A: Contract quantities</i> of the specification).
			Press Gauge Block	For supply & output pressures, Air Filter Regulator and other accessories shall be provided on as required basis for making system complete.
			Electrical Cable Entry	1/2"NPT, side or bottom entry to avoid water ingress.
			Valves Mounting Assembly	For Sliding Stem/Rotary/Single acting/Double acting actuators on as required basis
<p>* Note:</p> <p>Employer is providing a centralized HART management system including the HART multiplexing/ interfacing system. The HART signals shall be picked up from marshalling terminals of DDCMIS (SG/TG DDCMIS as well as BOP DDCMIS), as applicable. The details of the above mentioned employer's HART management system are as below:</p> <p>The following functionalities are achieved through industry standard softwares of the HART management system for electronic transmitters, temperature transmitters and analysers:</p> <ol style="list-style-type: none"> Constant scanning to monitor faults or changes to instrument configuration. Employer-defined and standard calibration and configuration procedures for all transmitters. Constant signal data collection facilities to maintain continuously updated records. Automatic tracking of configuration changes made in the field, such as may be introduced by hand-held communicator. All configuration function associated with hand-held communicators shall be available in the system. Event and log reports on screen as well as on printer. 				

CLAUSE NO.	TECHNICAL REQUIREMENTS 		
<p>8.00.00</p>	<p>f) Any addition/deletion of transmitter will be reported on printer and logged in hard disk.</p> <p>Further, the positioners shall be monitored from the above described HART management system .To achieve this, Bidder shall provide the necessary software to achieve the functionalities described above under "Remote Configuration and Diagnostics", and this software shall be loaded in the Employer's HART management system.</p> <p>TEST AND EXAMINATION</p> <p>All valves shall be tested in accordance with the quality assurance programme agreed between the Employer and Contractor, which shall meet the requirements of IBR and other applicable codes mentioned elsewhere in the specifications. The tests shall include but not be limited to the following:</p> <p>8.01.00 Non Destructive Test as per ANSI B-16.34.</p> <p>8.02.00 Hydrostatic shell test in accordance with ANSI B 16.34 prior to seat leakage test.</p> <p>8.03.00 Valve closure test and seat leakage test in accordance with ANSI-B 16.34 and as per the leakage class indicated above.</p> <p>8.04.00 Functional Test: The fully assembled valves including actuators control devices and accessories shall be functionally tested to demonstrate times from open to close position.</p> <p>8.05.00 CV Test: Please refer CI No. 1.00.00, Sub-section-IV:19 (Type test requirements), Control Valves.</p> <p>Bidder shall furnish all the control valves under this main plant package as finalized during detailed engineering stage without any price repercussions whatsoever depending on the process requirements. All the control valves provided by the Bidder for this project shall meet the specifications requirements specified herein. Specification for control valves in this Sub-section has to be read in conjunction with other relevant Sub-sections of this specification.</p>		
	t		

CLAUSE NO.	TECHNICAL REQUIREMENTS			
<p>10.00.00</p>	<p>FIELD MOUNTED LOCAL JUNCTION BOXES</p> <p>(i) No. of ways 12/24/36/48/64/72/96/128 with 20% spares terminals.</p> <p>(ii) Material and Thickness 4mm thick Fiberglass Reinforced Polyester (FRP).</p> <p>(iii) Type Door gasket shall be of synthetic rubber.</p>			

CLAUSE NO.	TECHNICAL REQUIREMENTS		
	<p>(iv) Mounting clamps and accessories</p> <p>(v) Type of terminal blocks</p> <p>(vi) Protection Class</p> <p>(vii) Grounding</p> <p>(viii) Color</p>	<p>Suitable for mounting on walls, columns, structures etc. The brackets, bolts, nuts, screws, glands and lugs required for erection shall be of brass, included in Bidders scope of supply. Raceways shall be provided inside JB's for proper termination of cables.</p> <p>Rail mounted cage-clamp type suitable for conductor size upto 2.5 mm². A M6 earthing stud shall be provided.</p> <p>IP: 55 minimum for indoor & IP-65 minimum for outdoor applications.</p> <p>To be provided.</p> <p>To be decided during detailed engineering & subject to Employer's approval.</p>	

	TECHNICAL REQUIREMENT FOR PRESSURE / DIFFERENTIAL PRESSURE GAUGE (Mechanical Auxiliary Packages)		SPECIFICATION NO.:		
			VOLUME		
			SECTION		
			REV. NO.	DATE:	
		SHEET	1	OF	1
Data Sheet No.: PE-DC-999-145-1026-0					
TECHNICAL REQUIREMENT FOR PRESSURE / DIFFERENTIAL PRESSURE GAUGE (TO BE FILLED BY PURCHASER)				(TO BE FILLED- UP/CONFIRMED BY BIDDER)	
GENERAL	MANUFACTURER				
	MODEL NUMBER				
TECHNICAL	SENSING ELEMENT		<input type="checkbox"/> BOURDON <input type="checkbox"/> DIAPHRAGM (BOURDON FOR HIGH PRESS AND DIAPHRAGM FOR LOW PRESS APPLICATION)		
	MATERIAL		SENSING ELEMENT – AISI 316 SS MOVEMENT – AISI 304 SS CASING – <input checked="" type="checkbox"/> DIE CAST AL <input type="checkbox"/> SS		
	ENCLOSURE		CLASS: <input checked="" type="checkbox"/> IP-55 <input type="checkbox"/> IP-65 <input type="checkbox"/> EXPL PROOF PAINT: <input checked="" type="checkbox"/> ENAMEL <input type="checkbox"/> EPOXY		
	DIAL		SIZE: 150 MM COLOR: WHITE NUMERALS: BLACK SCALE: LINEAR, 270° ARC GRADUATED IN METRIC UNITS		
	CASE		COLOUR : BLACK		
	SPAN/ ZERO ADJUSTMENT		INT. MICRO SCREW		
	RANGE SELECTION		SHOULD COVER 125% OF OPERATING PARAMETER		
	OVER RANGE PROTECTION		1.5 TIMES OF FSD		
	BLOW OUT DISC		REQUIRED		
	SWITCHING FACILITY (IF APPLICABLE)		NOT REQUIRED		
	TYPE		<input type="checkbox"/> MICRO SWITCH <input type="checkbox"/> OTHER		
NO. / TYPE OF CONTACTS		2 NOS. SPDT			
CONTACT RATING		5A 230V AC, 0.25A 220V DC			
SETTING RANGE		FIELD ADJUSTABLE OVER FULL RANGE			
REPEATABILITY		± 1% OF FSR			
POWER SUPPLY		<input type="checkbox"/> 230V AC <input type="checkbox"/> 110V AC			
PERFORMANCE	ACCURACY		± 1% OR BETTER OF FULL SCALE DEFLECTION		
CONNECTION	PROCESS		<input type="checkbox"/> M20 x 1.5 (M) <input checked="" type="checkbox"/> ½" NPT (M) <input type="checkbox"/> ½" NPT (F) <input type="checkbox"/> OTHER		
	LOCATION		BOTTOM		
ACCESSORIES	NAME PLATE / METAL TAG		SS		
	OTHER		SIPHON FOR STEAM, SNUBBER FOR PUMP DISCHARGE, CHEMICAL SEAL DIAPHRAGM FOR CORROSSIVE & OIL SERVICES TO BE PROVIDED		
OTHER REQUIREMENT	INSTRUMENT LIST		INSTRUMENT LIST COMPRISING OF TAG NO., SERVICE, DESIGN/OPERATING PRESSURE & TEMPERATURE TO BE ATTACHED		
QUALITY REQUIREMENT	CHECK LIST FOR PG/DPG		REFER CHECK LIST NO PE-CL-999-145-1 026-0		
NAME SIGNATURE DATE					
					NAME
					SIGNATURE
					DATE



**CHECK LIST FOR
PRESSURE / DIFFERENTIAL PRESSURE GAUGE
(Mechanical Auxiliary Packages)**

SPECIFICATION NO.:

VOLUME

SECTION

REV. NO.

DATE:

SHEET 1 OF 1

Data Sheet No.: PE-CL-999-145-1026-0

SL NO	TESTS/CHECKS	QUANTM OF CHECK	REFERENCE DOC. ACCEPTANCE NORMS	AGENCY			REMARKS
				P	W	V	
1.0	CHECK FOR		APPROVED TECHINCAL REQUIREMENT/ DATA SHEET				MFR TO CARRY OUT ROUTINE TEST ON 100%. WHEN MATL CORELATION ARE NOT AVAILABLE MFR'S COMPLIANCE TO BE PROVIDED
1.1	DIAL SIZE	100%		M	C	C	
1.2	MODEL NO/TAG NO	100%		M	C	C	
1.3	RANGE/SCALE	100%		M	C	C	
1.4	END CONNECTION	100%		M	C	C	
1.5	SWITCH CONTACT RATING & NOS	100%		M	C	C	
2.0	CALIBRATION						
2.1	ACCURACY	100%		M	C	B	
2.2	REPEATABILITY (FOR SWITCH)	100%		M	C	B	
2.3	SET POINT ADJUSTMENT FOR SWITCH	100%		M	C	C	
3.0	OVER PRESSURE & LEAK TEST	100%		M	C	C	
4.0	OPERATION OF PR. RELEIF DEVICE	ONE PER TYPE		M	C	C	
5.0	REVIEW OF T.C. FOR MATERIAL OF--						
5.1	SENSOR	FOR LOT	-	-	B		
5.2	MOVEMENT		-	-	B		
5.3	PROCESS CONNECTION		-	-	B		
5.4	HOUSING		-	-	B		
6.0	REVIEW OF T.C. FOR DEGREE OF PROTECTION	TYPE TEST	-	-	B		
7.0	REVIEW OF T.C. FOR CONTACT RATING OF SWITCH	ONE PER TYPE	-	-	B		
8.0	ACCESSORIES AS APPLICABLE	100%	M	C	C		

LEGEND:

M: MANUFACTURER/ SUB CONTRACTOR, C: CONTRACTOR/ NOMINATED INSP AGENCY, B: BHEL. P: PERFORM, W: WITNESS, V: VERIFICATION.

NOTE:

CONTRACTOR TO PROVIDE COMPLIANCE CERTIFICATE FOR TESTS/CHECKS VERIFIED BY CONTRACTOR AND SUBMIT THE SAME ALONGWITH TEST CERTIFICATES TO BE VERIFIED BY BHEL.

	PREPARED BY	CHECKED BY	APPROVED BY
NAME	S C NARANG/ MAYANK KESHARWANI	DIPESH PALIT	SHAILENDRA BHATNAGAR
SIGNATURE			
DATE	21.08.08	21.08.08	21.08.08

SPECIFICATION FOR ELECTRONIC TRANSMITTER FOR PRESSURE & D.P.	
ELECTRONIC TRANSMITTERS	
Sr. Features No.	Essential/Minimum Requirements
1. Type of Transmitter	Microprocessor based 2 wire type, Hart protocol compatible.
2. Accuracy	± 0.1% of calibrated span (minimum)
3. Output signal range	4-20 mA DC (Analog) alongwith superimposed digital signal (based on HART protocol)
4. Turn down ratio	10:1 for vacuum/very low pressure applications. 30:1 for other applications.
5. Stability	± 0.1% of calibrated span for six months for Ranges up to and including 70 Kg/cm ² . ± 0.25% of calibrated span for six months for Ranges more than 70 Kg/cm ² (g).
6. Zero and span drift	+/- 0.015% per deg.C at max span. +/-0.11% per deg.C at min. span.
7. Load impedance	500 ohm (min.)
8. Housing	Weather proof as per IP-55 with durable corrosion resistant coating.
9. Over Pressure	150% of max. Operating pressure
10. Connection (Electrical)	Plug and socket type
11. Process connection	1/2 inch NPT (F)

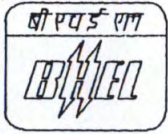

SPECIFICATION FOR LEVEL GAUGES

SPECIFICATION NO. : PES - 145 - 28A

VOLUME II B

SECTION D

REV. NO. 01 | DATE 27.03.95

SHEET 1 OF 2

1.0 TECHNICAL REQUIREMENTS

1.1 General

The Level Gauges shall be suitable for continuous operation under ambient temperature of 0-55°C and Relative Humidity of 0-95%.

1.2 Type of Level Gauge

The Level Gauge shall be Tubular or Transparent or Reflex or Magnetic type as specified in Data Sheet-A and shall be suitable for the specified service conditions.

1.2.1 Tubular Type

Borosilicate transparent glass tube shall be mounted between the top & bottom valve assemblies.

1.2.1.1 Gauge glass body: Body construction and assembly shall be suitable for on line replacement of the Glass tube without interrupting the equipment operation.

1.2.1.2 Protector: A tubular metallic protector with a slit in front for reading the level, shall be provided surrounding the gauge glass. The inside surface of the protector shall be painted yellow or white for clear visibility.

1.2.1.3 Ball Check: Ball check arrangement shall be provided inside the integral gauge glass valve body for automatic shut off and to prevent leakage of liquid during glass tube breakage under pressure or vacuum service.

1.2.1.4 Drain/Vent: The level gauge shall be provided with suitable venting arrangement on the upper arm and a drain valve/cock on the lower arm.

1.2.2 Transparent Type

Borosilicate toughened glass bars shall be mounted between the forged metal covers with top & bottom valve assemblies.

1.2.2.1 Ball Check: Ball check arrangement shall be provided inside the integral gauge glass valve body for automatic shut off and to prevent leakage of liquid during glass tube breakage under pressure or vacuum service.

1.2.2.2 Drain/Vent: The level gauge shall be provided with suitable venting arrangement on the upper arm and a drain valve on the lower arm.

1.2.2.3 Illuminator: Proper illuminating arrangement shall be provided for better visibility of the liquid level.

1.2.3 Reflex Type

Borosilicate toughened Reflex type glass bars shall be mounted between the forged metal covers with top & bottom valve assemblies.

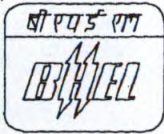

SPECIFICATION FOR LEVEL GAUGES

SPECIFICATION NO. : PES - 145 - 28A	
VOLUME	II B
SECTION	D
REV. NO. 01	DATE 27.03.95
SHEET 2	OF 2

1.2.3.1 Ball Check: Ball check arrangement shall be provided inside the integral gauge glass valve body for automatic shut off and to prevent leakage of liquid during glass tube breakage under pressure or vacuum service.

1.2.3.2 Drain/Vent: The level gauge shall be provided with suitable venting arrangement on the upper arm and a drain valve on the lower arm.

1.2.4 Magnetic Type

Magnetic type level gauge shall be suitable for either direct or indirect mounting as specified in Data Sheet-A. Direct type shall be suitable for mounting externally at the side of the vessel, while Indirect type shall be suitable for mounting at the top of the vessel. The level indication shall be by means of either rolling magnet or Iron ball follower, as specified in Data Sheet-A.

2.0 TESTING AND INSPECTION

2.1 The bidder shall adopt suitable quality assurance plan to ensure that the equipments offered will meet the specification requirements in full.

2.2 The bidder shall furnish the Quality Plan in the format enclosed in volume-III. In case the Quality Plan(s) is/ are included in volume-IIB, the bidder shall furnish his Quality Plan strictly in line with the same. The Quality Plan shall be discussed and finalised with the technically accepted bidders before opening the price bid. The stages where the purchaser would like to be associated for witnessing or verification would be indicated by the purchaser in the Quality Plan before approval.

2.3 The following test shall be conducted as a minimum requirement.

- a) Hydraulic pressure test for the complete gauge glass assembly at 1.25 times the maximum operating pressure.
- b) Thermal shock test for glass.

2.4 Inspection will be conducted by BHEL and/or their authorised representatives as per the agreed inspection schedule. The inspection schedule will be submitted by the bidder for BHEL's approval at contract stage. The cost of all tests and inspections will be deemed to have been included in the bid. For all the type tests covered under 2.3, "Type Test Certificates" as per agreed Quality Plan shall be furnished. In the absence of the same, such Type Tests shall be arranged at the Vendor's works in the presence of BHEL and/or their authorised representatives or in independent Test House/Laboratory approved by BHEL.

3.0 APPLICABLE DATA SHEET FORMS

This document shall be read with one or more of the following data sheet forms :

- Data sheet A&B for Level Gauges : Data sheet no. PES-145-28A-DS1-0
- Data sheet C for Level Gauges : Data sheet no. PES-145-28A-DS2-0



DATA SHEET FOR LEVEL GAUGES

SPECIFICATION NO. :	
VOLUME	
SECTION	
REV. NO.	DATE
SHEET 1	OF 1

Data Sheet No.: PES-145-28A-DS1-0

DATA SHEET A

Sl. No.	Description	Data Sheet-A (To be filled in by Purchaser)	
A.	GENERAL		<p><i>✓ Is applicable. To be confirmed by bidder.</i></p>
1.	Manufacturer		
2.	Model Number		
3.	Tag Number		
4.	Service a) Max. Operating Pressure b) Max. Operating Temp.		
5.	Range		
B.	TECHNICAL		
1.	Type	Tubular <input checked="" type="checkbox"/> Transparent <input type="checkbox"/> Reflex <input type="checkbox"/> Magnetic: Rolling Magnet <input type="checkbox"/> Iron bar <input type="checkbox"/> (with metallic tube protects with a slit) Direct <input checked="" type="checkbox"/> Indirect <input type="checkbox"/> Top <input type="checkbox"/> Side <input checked="" type="checkbox"/>	
2.	Mounting		
3.	Material Body Ball Spindle/Gland Gasket Glass Tube/Glass plate Valves Hand wheel Bolt & Nuts Chamber Float	ASTM: A105 <input type="checkbox"/> SS304 <input checked="" type="checkbox"/> SS316 <input type="checkbox"/> SS-304 SS-304 Neoprene <input checked="" type="checkbox"/> Teflon <input type="checkbox"/> Other <input type="checkbox"/> Borosilicate Toughened SS-304 <input checked="" type="checkbox"/> Malleable iron High Tensile steel SS-304 <input type="checkbox"/> SS-316 <input type="checkbox"/> Other <input type="checkbox"/> SS-304 <input type="checkbox"/> SS-316 <input type="checkbox"/> Other <input type="checkbox"/>	
4.	Illuminator a) Class of protection b) Power supply	Yes <input type="checkbox"/> No <input checked="" type="checkbox"/> IP 55 <input type="checkbox"/> IP 65 <input type="checkbox"/> Flame proof (IS-2148) <input type="checkbox"/> 240V AC 50 Hz. <input type="checkbox"/> 110V AC 50 Hz. <input type="checkbox"/>	
5.	Mica Shield (>400°C, Transparent type)	Yes <input type="checkbox"/> No <input checked="" type="checkbox"/>	
6.	Valve Type	Inlined <input checked="" type="checkbox"/> Offset <input type="checkbox"/>	
7.	Drain cock/valve	Cock <input type="checkbox"/> Valve <input checked="" type="checkbox"/>	
C.	CONNECTION		
1.	Type, Size & Rating		
2.	Centre to Centre distance		
3.	Nuts, bolts, gaskets for conn.	Yes <input checked="" type="checkbox"/> No <input type="checkbox"/>	



DATA SHEET FOR LEVEL GAUGES

SPECIFICATION NO. :

VOLUME

SECTION

REV. NO.

DATE

SHEET

1

OF

1

Data Sheet No.: PES-145-28A-DS2-0

DATA SHEET-C

Sl. No.	Description	Data Sheet-C (To be filled in by Contractor after award of contract)	Remarks
A.	GENERAL		
1.	Manufacturer		
2.	Model Number		
3.	Tag Number		
4.	Service		
	a) Max. Operating Pressure		
	b) Max. Operating Temp.		
5.	Range		
B.	TECHNICAL		
1.	Type		
2.	Mounting		
3.	Material		
	Body		
	Ball		
	Spindle/Gland		
	Gasket		
	Glass Tube/Glass plate		
	Valves		
	Hand wheel		
	Bolt & Nuts		
	Chamber		
	Float		
4.	Illuminator		
	a) Class of protection		
	b) Flame proof (IS 2148)		
	c) Power supply		
5.	Mica Shield (>400°C, Transparent type)		
6.	Valve Type		
7.	Drain cock/valve		
C.	CONNECTION		
1.	Type, Size & Rating		
2.	Centre to Centre distance		
3.	Nuts, bolts, gaskets for conn.		



SPECIFICATION FOR LOCAL PANELS

SPECIFICATION NO.: PES – 145 – 054A	
VOLUME	II B
SECTION	D
REV. NO.	02
DATE :	22-02-2008

1.0 SCOPE

This specification covers the Design, Manufacture, Inspection and Testing at the manufacturer's works, proper packing for transportation and delivery to site of Local Panels required for control and monitoring of the Auxiliary Plant & Equipment.

2.0 CODES AND STANDARDS

2.1 All the equipments specified herein shall comply with the requirements of the latest issue of the relevant National and International standards.

2.2 As a minimum requirement, the following standards shall be complied with:

- | | | | |
|----|--------------------------|---|---------------------------------------------------------------------------------|
| a) | IS-6005 : 1970 | : | Code of practice for phosphating of iron and steel. |
| b) | IS-5 : 1978 | : | Colours for ready mixed paints and enamels. |
| c) | IS-1248:1983 | : | Direct Acting Indicating Instruments. |
| d) | IS-13947 (Part-III):1993 | : | Rotary Cam Switches. |
| e) | IS-6875:1973 | : | Auxiliary relays. |
| f) | IS-8828:1993 | : | Circuit breaker for household and similar installations. |
| g) | IS-13947 (Part-I):1993 | : | Low Voltage switchgear & control gear : Part-I (General Rules) |
| h) | NFPA-496:1974 | : | Purged & Pressurised Enclosure for Electrical Equipment in Hazardous Locations. |

3.0 TECHNICAL REQUIREMENTS

3.1 Panel Construction

3.1.1 The local panels shall house the secondary instruments, annunciation system, Single loop controller, Control switches / push buttons, indicating lamps, relays, timers and other devices required for operation and monitoring of the equipment locally.

3.1.2 The panels shall be of free standing type either welded construction on angle iron (minimum section of 50 x 50 x 4 mm) structure or folded construction by sheet metal formation depending upon the equipments to be mounted on it. The panels shall be robustly built and stiffeners as necessary shall be provided.

3.1.3 The panel shall be suitably reinforced to ensure adequate support for all instruments mounted thereon. All welds on exposed panel surfaces shall be ground smooth.

3.1.4 The salient features of construction shall be:

Sheet material: Cold rolled sheet steel

Frame thickness: Not less than 3.0mm

Enclosure thickness: Not less than 2.5 mm for load bearing sections (Mounted with instruments),
1.6 mm for doors and Not less than 2.0 mm for others

Panel Height: Not less than 2365 mm

Gland plate thickness: 3.0mm

Base channel: ISMC 100 with anti-vibration mounting & foundation bolts.

3.1.5 The panel shall be provided with rear doors with integral lockable handle. The door when locked shall be held at minimum three places. The door width shall not be more than 550mm. The doors shall be provided with suitable stiffeners to prevent buckling. The handle shall be on the right side of the door. The door shall be removable type with concealed hinges to facilitate maintenance work. Suitable pocket inside the door shall be provided for keeping the drawings / documents.

3.1.6 Suitable neoprene gasket shall be provided on all doors and removable covers. Suitable ventilation louvers shall be provided at bottom and top of the doors covered with removable wire mesh.



SPECIFICATION FOR LOCAL PANELS

SPECIFICATION NO.: PES – 145 – 054A	
VOLUME	II B
SECTION	D
REV. NO.	02
DATE	: 22-02-2008

- 3.1.7 The class of protection shall be in accordance with IP-42 unless otherwise specified in the data sheet – A (No. PES-145-54A-DS1-0).
- 3.1.8 All steel surfaces shall be cleaned by sand / pellet blasting, treated for pickling, degreasing and phosphating etc. by seven tank method. The panel shall have a high quality finish and appearance. The panel shall be painted with two coats of primer followed by two coats of epoxy / synthetic enamel based final paint of color shade and finish as given in data sheet-A (No. PES-145-54A-DS1-0). Minimum thickness of the paint shall be 85 microns for external paint and 70 microns for internal paint.
- 3.1.9 The cable glands of the required size and type as given in data sheet-A (No. PES-145-54A-DS1-0) shall be supplied alongwith the Panel.
- 3.1.10 All operable and indicating devices shall be mounted on the front of the panel while aux. Relays / timers MCBs etc. required for realization of control logics shall be mounted on a mounting plate inside the panel. Auxiliary relays and timers etc. shall be grouped according to the control function. No operable or indicating devices shall be mounted below 750 mm and above 1800 mm (w.r.t. finished ground level). The devices shall be located in such a way so as to ensure easy access for operation / maintenance.
- 3.1.11 Single / dual control power supply feeders of voltage class as specified in data sheet-A (No. PES-145-54A-DS1-0) shall be provided by the purchaser. **In case redundant power supply feeders are provided then auto changeover unit shall be mounted on the panel are in the panel supplier's scope.** Where DC control power supply is specified an additional 240V, 50 Hz AC supply feeder for powering of space heater and lighting shall be provided by the purchaser. Suitable arrangement shall be provided inside the panel to receive and terminate the power supply feeder(s). For this purpose MCBs of suitable current rating shall be provided by the vendor. A supervisory relay along with a pilot lamp to indicate control supply 'ON' shall be provided on the panel. Any other power supply required for the operation of the devices mounted in the panel shall be arranged by the vendor.
- 3.1.12 The internal wiring shall be carried out with 1100 volt grade PVC insulated copper multi strand wire / flexible of 1.5mm² size. AC & DC wires shall be kept separate from each other. Separate coloured wires to be used for AC and DC circuits. All wires shall be properly numbered and identified with ferrules as per the Control scheme / wiring diagram. Wires shall be routed and run through PVC troughs.
- 3.1.13 Terminal blocks shall be clip on type, 1100 volts grade. Separate terminal blocks shall be used for AC & DC circuits. The terminals shall be suitable for terminating 0.5 mm² to 2.5mm² external cables. The terminal for ammeters shall be provided with removable links for shorting CTs. Each terminal strip shall be provided with identification strip. The terminal shall not be mounted below 250 mm **height from finished floor**. The panel shall have ten (10) percent spare terminal.
- 3.1.14 The interior of each panel shall be suitably illuminated through fluorescent lamps operable on 240V 50 Hz AC power supply through panel door switch. A 15 Amp. 3-pin Power receptacle shall be provided.
- 3.1.15 Suitable space heaters operable on 240 Volts 50 Hz AC power system shall be provided at the panel bottom. These shall be designed to maintain the panel temperature five (5) deg. C above the ambient temperature during maintenance shutdown. Suitable isolating and control devices comprising of MCB, thermostat etc. shall be provided for the space heater.
- 3.1.16 The panel shall be provided with a copper earth bus of 25 x 6 mm size running throughout the width of the panel. It shall be terminated internally with 10 mm bolts at extreme ends for connection to; main station earth. The panel mounted equipments / devices shall be connected to earth bus through green coloured PVC insulated stranded copper conductor of 2.5 mm² size.
- 3.1.17 Local Panel shall be provided with main name plate of 150 mm x 40 mm size having inscription of 20 mm height. The individual devices on the panels shall be as provided with separate name plate with inscription of 3 mm height. The instrument / devices shall be provided with stick on label plates inside the panel. The material of the main and individual labels shall be three (3) ply 3 mm thick Traffolyte Sheet / 2 mm Anodised Aluminium Plate. The inscription shall be with white letters on black background on traffolyte sheet. The labels shall be fixed by self tapping non-rusting screws.



SPECIFICATION FOR LOCAL PANELS

SPECIFICATION NO.: PES – 145 – 054A	
VOLUME	II B
SECTION	D
REV. NO.	02
DATE :	22-02-2008

3.2 Hazardous Area Panel Requirement

3.2.1 The Local Panel located in hazardous area shall be pressurized as per NFPA-496 requirements to render it non-hazardous. Alarms shall be provided for local and remote annunciation when pressurisation falls below 2.5 mm of water column. Protection shall be of type Z of NFPA-496. It shall not be possible to switch ON the power of purged section unless it is purged as per the recommendation of NFPA-496. Vendor must provide a protective device on the panel to protect the panel from over pressurisation.

3.2.2 Vendor shall supply pressurisation kit consisting of valves, restriction orifices, dual filter regulation, pressure gauges, pressure switches, rotameter etc. Pressurisation kit shall be surface mounting on a metal board and located outside the local panel. Pressurisation kit shall further consist of solenoid valve flow switch, timer blow off safety device etc., so as to make purging fully automatic. However final start shall be manual. Panel protection against over pressure to be provided as per NFPA-496.

3.2.3 Pressurised local control panel pressurization kit assembly design shall provide minimum leakage flow through the Local Control Panel. Panel venting shall be as per NFPA-496.

3.2.4 All components in the local panel like indicating instruments, push buttons switches, lamps etc., which are required to be energized without panel pressurization or before completion of purge cycle shall be explosion proof as per NEMA-7 & suitable for area classification.

3.2.5 All push buttons etc. requiring frequent operation during machine running shall have good positive sealing. Weatherproof housing or cover to be provided wherever necessary. Vendor shall provide pressurisation bypass switch outside explosion proof enclosure of pressurized panel with lamp indication. This shall be used only during maintenance. All hinges, screws, other non-painted metallic parts shall be of stainless steel material.

3.2.6 Provision to switch off manually all types of power shall be provided in the panel. In addition, it shall also be possible to switch off power circuits / components which are powered from motor control centre or control room manually in case of pressurization failure. All such cables from MCC and main control room shall be terminated in explosion proof boxes (NEMA-7).

3.3 Control & Monitoring devices

3.3.1 Instruments like Indicators, recorders, single loop controllers etc. as applicable and specified elsewhere for the plant / equipment shall be supplied and mounted on the panel.

3.3.2 Alarm Annunciator System

It shall be solid state discrete facia type having a sequence of ISA-S18.1A or as specified, opaque facia windows of 70 mm x 50 mm size, having two (2) lamps per window, and hooter of 10W, and provision for repeat group alarm at remote. The annunciator shall be provided with ten (10) percent spare windows or minimum two (2) windows along with electronics.

3.3.3 Relays

The relays shall be electromagnetic type suitable for specified control supply. Its contact configuration and rating shall be suitable for the specified control function. However minimum contact rating shall be 5 Amp AC & 2 Amp DC as applicable. There shall be ten (10) percent spare contacts.

3.3.4 Timers

The timers shall be electronic type suitable for specified control supply. Its contact configuration and rating shall be suitable for the specified control function. However, minimum contact rating shall be 5 Amp AC & 2 Amp DC as applicable.

3.3.5 Control / Selector Switches

Switches shall be Rotary Cam type with minimum of 5 Amps AC & 2 Amp DC continuous current rating. Selector switches shall be stay put type while control switches shall be spring-return-to-neutral type. Contact configuration and rating shall be as per the control function requirement. The switches shall be lockable type wherever specified. Each switch shall be provided with engraved plates indicating the switch position / functions.



SPECIFICATION FOR LOCAL PANELS

SPECIFICATION NO.: PES – 145 – 054A	
VOLUME	II B
SECTION	D
REV. NO.	02
DATE :	22-02-2008

3.3.6 Push Buttons / Indicating Lights

The push buttons shall be momentary action self-resetting type, however stop P.B. for unidirectional drives shall be provided with manual reset facility. Its contact configuration & rating shall be as required for the control function but minimum 2 NO + 2 NC of 5 Amp. AC rating. It shall have round coloured projecting tab and engraved escutcheon plate / inscription plate. Colour coding of push buttons shall be as under:

RED	Motor OFF / Valve CLOSE	YELLOW	Alarm acknowledge.
GREEN	Motor ON / Valve OPEN	BLACK	Lamp test

Indicating lights shall be suitable for direct connections across specified power supplies. It shall be fitted with built in resistance to prevent circuit tripping on shorting of lamp filament. It shall be fitted with LED cluster type lamp replaceable from front.

GREEN	Motor OFF / Valve CLOSED condition	AMBER	Motor tripped condition.
RED	Motor ON / Valve OPEN condition	WHITE	Normal / healthy condition

3.3.7 Ammeters

Ammeter shall be 96 x 96 mm size, 90 deg. deflection, 1.5% accuracy, 1 Amp. CT operated or with 4-20mA input and Flush mounting type as called for in the data sheet-A (No. PES-145-54A-DS1-0). Ammeters for motors shall have six (6) times folded scale at upper end to enable motor starting current indication.

3.3.8 Miniature Circuit Breaker (MCB)

These shall be instantaneous magnetic trip type for short circuit in addition to current time inverse delayed thermal trip feature for over current protection. The housing of MCB shall be made of non-ignitable, high impact material. It shall have minimum short circuit rating of 9 KA for AC Voltages and 4 KA for DC Voltages.

3.3.9 Makes of various instruments / devices shall be as given below

1.	Alarm Annunciators	:	Procon / IIC
2.	Ammeters	:	AEP / IMP
3.	Control / Selector Switches	:	Alsthom / Kaycee / Siemens / L&T
4.	Push Buttons / Indicating Lamps	:	Siemens / L&T / Teknic / Alsthom
5.	Auxiliary Relays	:	Jyoti / Siemens / L&T / OEN
6.	Timers	:	L&T / Alsthom / Bhartiya Cutler Hammer
7.	MCBs	:	S&S Power Engg. / Indo Asian / MDS
8.	Terminal Blocks	:	Jyoti / Elmex

4.0 TESTING AND INSPECTION

4.1 The bidder shall adopt suitable quality assurance program to ensure that the equipments offered will meet the specification requirements in full.

4.2 BHEL's standard Quality Plan for LCP is enclosed with the specification. The bidder shall furnish his acceptance to BHEL's QP and submit the signed and stamped copy of QP along with the offer.

4.3 The vendor shall conduct the following tests as a minimum requirement:

4.3.1 Routine Tests

1. High Voltage (H.V.)
2. Insulation Resistance (I.R.)
3. Functional

4.3.2 Type Tests

1. Enclosure Class Test



SPECIFICATION FOR LOCAL PANELS

SPECIFICATION NO.: PES – 145 – 054A	
VOLUME	II B
SECTION	D
REV. NO.	02
DATE :	22-02-2008

5.0 SPARES AND CONSUMABLES

5.1 Commissioning Spares and consumables

The bidder shall supply all commissioning spares and consumables 'as required' during Start-up, as part of the main equipment supply.

5.2. Mandatory Spares

The bidder shall offer alongwith main offer, the Mandatory Spares as specified elsewhere in the specification. The Mandatory Spares offered shall be of the same make and type as the main equipment.

5.3. Recommended Spares

The bidder shall furnish a list of Recommended Spares indicating the normal service expectancy period and frequency of replacement; quantities recommended for 3 years operation alongwith unit rate against each item to enable BHEL/BHEL's Customer to place a separate order later, if required.

6.0 DRAWINGS AND DOCUMENTS

6.1 The bidder shall furnish the following documents in required number of copies along with the bid :

1. Data Sheet no. PES-145-54A-DS1-0
2. General Arrangement Drawing.
3. Catalogue and technical information for instruments and devices.
4. Quality Plan.

6.2 The vendor shall furnish the following documents in required number as agreed after the award of contract:

1. Data Shee No. PES-145-54A-DS2-0
2. GA Drawing indicating layout of instruments, construction details, foundation details, cable gland plate alongwith cable glands and all details mentioned in this specification.
3. Control Schematic Diagram along with grouping of different terminals for various functions.
4. Catalogue and technical information for instruments and devices with selected options clearly marked.
5. O&M Manuals.
6. "As Built" Drawing.
7. **CDs.**

7.0 MARKING AND PACKING

7.1 Panel with all instruments / devices mounted on it shall be suitably packed & protected for the entire period of despatch, storage and erection against impact, abrasion, corrosion, incidental damage due to vermin, sunlight, high temperature, rain moisture, humidity, dust, sea-water spray (where applicable) as well as rough handling and delays in Transit and storage in open.

8.0 APPLICABLE DATA SHEET FORMS

This document shall be read with one or more of the following data sheet forms :

- | | | |
|-----------------------------------|---|----------------------------------|
| - Data sheet A&B for Local Panels | : | Data sheet no. PES-145-54A-DS1-0 |
| - Data sheet C for Local Panels | : | Data sheet no. PES-145-54A-DS2-0 |



DATA SHEET FOR LOCAL PANELS

SPECIFICATION NO.:	
VOLUME	
SECTION	
REV. NO.	DATE:

TAG No. Qty.....	Data Sheet No.: PES-145A-DS1-0
Data Sheet A & B	

DATA SHEET-A FOR LOCAL PANEL (TO BE FILLED BY PURCHASER)	DATA SHEET-B (TO BE FILLED-UP BY BIDDER)
-------------------------------------------------------------	---------------------------------------------

GENERAL	MANUFACTURER		
	CONSTRUCTION		<input checked="" type="checkbox"/> FOLDED <input type="checkbox"/> WELDED (As per requirement)
	ENCLOSURE SHEET THICKNESS	FRONT	<input checked="" type="checkbox"/> 2.5 mm
		OTHER	<input checked="" type="checkbox"/> 2.0 mm
DOOR		<input checked="" type="checkbox"/> 1.6 mm	
TECHNICAL	INPUT POWER SUPPLY		<input checked="" type="checkbox"/> 240V 50 Hz AC <input type="checkbox"/> 220V DC <input checked="" type="checkbox"/> 415V 3 PHASE <input type="checkbox"/> (As required)
	NO. OF FEEDERS		<input type="checkbox"/> ONE <input checked="" type="checkbox"/> TWO
	CONTROL SUPPLY		<input type="checkbox"/> 110V AC <input checked="" type="checkbox"/> 220V AC <input type="checkbox"/> 220V DC <input type="checkbox"/> (As per requirement)
	ALARM ANNUNCIATOR WINDOW (EXCLUDING SPARES)		<i>During detailed enq</i> NOS. (AS REQUIRED)
	PAINT TYPE		<input type="checkbox"/> EPOXY ENAMEL <input checked="" type="checkbox"/> EPOXY POWDER COATED
	PANEL COLOUR (EXTERNAL)		<input type="checkbox"/> LIGHT GREY (Shade 631 IS-5) <i>During detailed enq</i> <input type="checkbox"/> OPALINE GREEN (Shade 275) <input type="checkbox"/>
	FINISH		<input type="checkbox"/> MATT <input type="checkbox"/> GLOSSY <input checked="" type="checkbox"/> SEMI GLOSSY
	PANEL COLOUR (INTERNAL)		<input checked="" type="checkbox"/> WHITE <input type="checkbox"/> CREAM <input type="checkbox"/> OFF WHITE
	FINISH		<input type="checkbox"/> MATT <input checked="" type="checkbox"/> GLOSSY <input type="checkbox"/> SEMI GLOSSY
	CLASS OF PROTECTION		<input type="checkbox"/> IP-42 <input checked="" type="checkbox"/> IP-54
	CONTROL HARDWARE		<input checked="" type="checkbox"/> RELAY BASED (<i>whenever required</i>)
	FOUNDATION ARRANGEMENT		<input checked="" type="checkbox"/> FOUNDATION BOLTS <input type="checkbox"/> ANCHOR FASTENERS
	WEIGHT OF PANEL (Kg.)		
	PANEL TYPE		<input type="checkbox"/> PRESSURISED <input checked="" type="checkbox"/> UNPRESSURISED As per Requirement
	CABLE GLAND		<input type="checkbox"/> SINGLE COMPRESSION <input checked="" type="checkbox"/> DOUBLE COMPRESSION
	AAMETER (TYPE OF INPUT)		<input type="checkbox"/> 1 Amp CT <input type="checkbox"/> 4-20 mA
NAME SIGNATURE DATE	PREPARED BY	CHECKED BY	APPROVED BY
			COMPANY SEAL
			NAME
			SIGNATURE
			DATE



DATA SHEET FOR LOCAL PANELS

SPECIFICATION NO.:	
VOLUME	
SECTION	
REV. NO.	DATE:

TAG No. Qty.....

Data Sheet No.: **PES-145A-DS1-0**

Data Sheet C

DATA SHEET-C FOR LOCAL PANEL
(TO BE FILLED BY CONTRACTOR AFTER AWARD OF CONTRACT)

GENERAL	MANUFACTURER		
	CONSTRUCTION		
	ENCLOSURE SHEET THICKNESS	FRONT	
		OTHER	
DOOR			
TECHNICAL	INPUT POWER SUPPLY		
	NO. OF FEEDERS		
	CONTROL SUPPLY		
	ALARM ANNUNCIATOR WINDOW (EXCLUDING SPARES)		
	PAINT TYPE		
	PANEL COLOUR (EXTERNAL)		
	FINISH		
	PANEL COLOUR (INTERNAL)		
	FINISH		
	CLASS OF PROTECTION		
	CONTROL HARDWARE		
	FOUNDATION ARRANGEMENT		
	WEIGHT OF PANEL (Kg.)		
	PANEL TYPE		
	CABLE GLAND		
AAMETER (TYPE OF INPUT)			
NAME SIGNATURE DATE	PREPARED BY	CHECKED BY	APPROVED BY
	COMPANY SEAL		
			NAME
			SIGNATURE
			DATE



**TECHNICAL SPECIFICATION FOR
HYDROGEN GENERATION PLANT
2 X 800 MW NTPC GADERWARA STPP STAGE-I**

SPEC NO.PE-TS-394-168-A001	
VOLUME-IIB	
SECTION	
REV.NO.0	DATE
SHEET	

INSTRUMENTATION AND POWER SUPPLY CABLE

INSTRUMENTATION AND POWER SUPPLY CABLE

1.00.00 INSTRUMENTATION CABLE, POWER SUPPLY CABLE, INTERNAL WIRING AND ELECTRICAL FIELD CONSTRUCTION MATERIAL

1.01.00 General Requirements

1.01.01 All cables including special cables, internal wiring and electrical field construction material shall conform to this specification, Employer approved detail engineering drawings & documents and the latest edition of the relevant standards & guidelines. The Bidder shall furnish all material and services required for the completeness of the work identified in his scope as per this specification.

1.01.02 The Contractor shall supply, erect, terminate and test all instrumentation cables for control and instrumentation equipment/devices/systems included under Contractor's scope as illustrated in the enclosed Drg. No. 0000-110-POI-A-021 and ensuring completeness of the control system.

1.01.03 Any other application where it is felt that instrumentation cables are required due to system/operating condition requirements, are also to be provided by Contractor.

1.01.04 Other type of cables like fiber optic/co-axial cables for system bus, cables for connection of peripherals etc. (under Contractor's scope) are also to be furnished by the Contractor.

1.01.05 Contractor shall supply all cable erection and laying hardware from the main trunk routes like branch cable trays/sub-trays, supports, flexible conduits, cable glands, lugs, pull boxes etc. on as required basis for all the systems covered under this specification.

1.01.06 Wherever the quantity has been defined as on as required basis, the same are to be furnished by contractor on as required basis within his quoted lump sump price without any further cost implication to the Employer.

2.00.00 Specification of Instrumentation cable

2.01.00 Common Requirements

S. No.	Property	Requirement
1	Voltage grade	225 V (peak value)
2.	Codes and standard	All instrumentation cables shall comply with VDE 0815, VDE 0207, Part 4, Part 5, Part 6, VDE 0816, VDE 0472, SEN 4241475, ANSI MC 96.1, IS-8784, IS-

S. No.	Property	Requirement
		10810 (latest editions) and their amendments read along with this specification.
3.	Continuous operation suitability	At 70 deg. C for all types of cables, while 205 Deg C for Type-C cables.
4.	Progressive automatic on-line sequential marking of length in meters	To be provided at every one meter on outer sheath.
5.	Marking to read 'FRLS'	To be provided at every 5 meters on outer sheath except for Type-C cable.
6.	Allowable Tolerance on overall diameter	+/- 2 mm (maximum) over the declared value in data sheet
7.	Variation in diameter	Not more than 1.0 mm throughout the length of cable.
8	Ovality at any cross-section	Not more than 1.0 mm
9	Others	<p>a) Durable marking at intervals not exceeding 625 mm shall include manufacturer's name, insulation material, conductor's size, number of pairs, voltage rating, type of cable, year of manufacturer to be provided.</p> <p>b) Cables shall be suitable for laying in conduits, ducts, trenches, racks and underground-buried installation</p> <p>c) Repaired cables shall not be acceptable.</p>

2.02.00	Specific Requirements				
	Specification Requirements	Type-A cable	Type-B cable	Type F & G cable	Type-C cable
	A. Conductors				
	Cross section area	0.5 sq. mm			
	Conductor material	ANSI type KX	ANSI type SX	High conductivity Annealed bare copper	ANSI type KX
	Colour code	Yellow-Red	Black-Red	As per VDE-815	Yellow-Red
	Conductor Grade	As per ANSI MC 96.1		Electrolytic	As per ANSI MC 96.1
	No & dia of strands	7x0.3 mm (nom)			
	No. of Pairs	2	2	4,8,12,16,24,48	2
	Max. conductor resistance per Km (in ohm) at 20 deg. C	As per ANSI MC 96.1		73.4 (loop)	As per ANSI MC 96.1
	Reference Standard	As per ANSI MC 96.1		VDE 0815	As per ANSI MC 96.1
	B. Insulation				
	Material	PVC type YI 3			Teflon (i.e. extruded FEP)
	Thickness in mm (Min/Nom/Max)	0.25/0.3/0.35			0.4/0.50
	Volume Resistivity (Min) in ohm-cm	1 x 10 ¹⁴ at 20 deg. C & 1x10 ¹¹ at 70 deg. C.			---

Voltage Rating	225 V peak operating voltage			
Reference Standard	VDE 0207 Part 4		VDE 0207 Part 6 & ASTM D 2116.	
Core diameter above insulation	Suitable for cage clamp connector			
C. Pairing & Twisting				
Max. lay of pairs (mm)	50			
Single layer of Polyester tape on each pair provided	Numbered tape	Yes	N.A.	
Unit formation of four pairs with printing of no. of Unit provided	N.A.	Yes	N.A.	
Conductor /pair identification as per VDE0815	N.A.	To be provided (color coding attached).	N.A.	
D. Shielding				
Type of shielding	Al-Mylar tape			
Individual pair shielding	No	To be provided for F-type cable	No	
Minimum thickness of Individual pair shielding	No	28 micron	No	
Overall cable assembly shielding	To be provided			
Minimum thickness of	55 micron			

Overall cable assembly shielding			
Shielding coverage	100% with at least 20% overlap		
Drain wire provided for individual shield	N.A.	Yes (for F-type) 7-strand 20 AWG (0.51 mm ²) annealed Tin coated copper	N.A.
Drain wire provided for overall shield	Yes. 7-strand 20 AWG (0.51 mm ²) annealed Tin coated copper		
E. FILLERS			
Non-hygroscopic, flame retardant	To be provided		
F. Outer Sheath			
Material	Extruded PVC compound YM1 with FRLS properties		Teflon (i.e. extruded FRP)
Minimum Thickness at any point	1.8 mm		0.4 mm
Nominal Thickness at any point	>1.8 mm		0.5 mm
Color	Blue		
Resistant to water, fungus, termite & rodent attack	Required		
Oxygen index as per ASTMD-2863	not less than 29%		N.A.

Temperature index as per ASTM D-2863	not less than 250 deg.C		N.A.	
acid gas generation by weight as per IEC-60754-1	Maximum 20%		N.A.	
Smoke Density Rating as per ASTM D-2843	Maximum 60% (defined as the average area under the curve when the results of smoke density test plotted on a curve indicating light absorption vs. time as per ASTM D-2843)		N.A.	
Reference standard	VDE207 Part 5		VDE207 Part 6 & ASTM D2116	
G. Electrical Parameters				
MUTUAL CAPACITANCE BETWEEN CONDUCTORS AT 0.8 KHZ (MAX.)	200 nF/km	120 nF/km for F type 100 nF/km for G-type	200 nF/km	
INSULATION RESISTANCE (MIN)	100 M Ohm/Km			
CROSS TALK FIGURE (MIN.) AT 0.8 KHZ	60 Db	60 dB	N.A.	
CHARACTERISTIC IMPEDANCE (MAX) AT 1 KHZ	N.A.	320 ohm for F-type 340 ohm for G-type	N.A.	
ATTENUATION	N.A.	1.2 db/km	N.A.	

	FIGURE AT 1 KHZ (MAX)			
	H. Complete Cable			
	Complete Cable assembly	Shall pass Swedish Chimney test as per SEN-SS 4241475 class F3.		N.A.
	Flammability	Shall pass flammability as per IEEE-383 read in conjunction to this specification		N.A.
	I. Accessories			
	Cable accessories of flame retardant quality.	Yes. (Accessories such as harnessing components, markers, bedding, cable jointer, binding tape etc.)		
	J. Tests			
	Routine & Acceptance tests	Refer sub-section III E		
	Type tests	Refer sub-section-CNI TYPE TEST		
	K Cable Drum			
	Type	Non-returnable wooden drum (wooden drum to be constructed from seasoned wood free from defects with wood preservative applied to the entire drum) or steel drum.		
	Outermost layer covered with waterproof paper	Yes		
	Painting	Entire surface to be painted		
	Length	1000 m \pm 5% for up to & including 12 pairs 500 m \pm 5% for above 12 pairs		
3.00.00	SPECIFICATION OF OPTICAL FIBER CABLES (OFC)			
3.01.00	Optic Fiber cable shall be 4/8/12 core, galvanised corrugated steel taped armoured, fully water blocked with dielectric central member for outdoor/indoor application so as to prevent any physical damage. The cable shall have multiple single-mode or			

	<p>multi mode fibers on as required basis so as to avoid the usage of any repeaters. The core and cladding diameter shall be 9 +/- 1 micrometer and 125 +/- 1 micrometer respectively. The outer sheath shall have Flame Retardant, UV resistant properties and are to be identified with the manufacturer's name, year of manufacturer, progressive automatic sequential on-line marking of length in meters at every meter on outer sheath.</p>
3.02.00	<p>The cable core shall have suitable characteristics and strengthening for prevention of damage during pulling viz. Steel central member, Loose buffer tube design, 4 fibers per buffer tube (minimum), Interstices and buffer tubes duly filled with Thixotropic jelly etc. The cable shall be suitable for a maximum tensile force of 2000 N during installation, and once installed, a tensile force of 1000 N minimum. The compressive strength of cable shall be 3000 N minimum & crush resistance 4000 N minimum. The operating temperature shall be -20 deg. C to 70 deg. C</p>
3.03.00	<p>All testing of the fiber optic cable being supplied shall be as per the relevant IEC, EIA and other international standards.</p>
3.04.00	<p>Bidder to ensure that minimum 100% cores are kept as spares in all types of optical fibre cables.</p>
3.05.00	<p>Cables shall be suitable for laying in conduits, ducts, trenches, racks and under ground buried installation.</p>
3.06.00	<p>Spliced / Repaired cables are not acceptable.</p>
3.07.00	<p>Penetration of water resistance and impact resistance shall be as per IEC standard.</p>
4.00.00	<p>SPCIFICATION OF POWER SUPPLY CABLES</p> <p>Refer relevant subsections of this specification.</p>
5.00.00	<p>INSTRUMENTATION CABLE INTERCONNECTION AND TERMINATION PHILOSOPHY</p> <p>The cable interconnection philosophy to be adopted shall be such that extensive grouping of signals by large scale use of field mounted Group Junction Boxes (JBs) at strategic locations (where large concentration of signals are available, e.g. valves limit & torque switches, switchgear) is done and consequently cable with higher number of pairs are extensively used. The details of termination to be followed are mentioned in the given Table A.</p>

TABLE A: CABLE TERMINATION TO BE FOLLOWED

Application		Type Of Termination		Type Of Cable
FROM (A)	TO (B)	END A	END B	
Valves/dampers drives (Integral Junction box)	Marshalling cubicle/ Marshalling cum termination Cubicle/local group JB	Plug in connector	Posts mount cage clamp type.	G
Transmitters, Process Actuated switches mounted in LIE/LIR	Integral Junction box of LIE/LIR	Plug in connector	Cage clamp (Rail mount) type.	F,G
RTD heads	Local junction box	Plug in connector	Cage clamp (Rail mount) type.	F
Thermocouple	CJC Box (if applicable)	Plug in connector	Cage clamp (Rail mount) type.	A,B,C*
Other Field Mounted Instrument	Local JB/Group JB	Plug in connector	Screwed, Cage clamp (Rail mount) type	F,G
RTD	Temperature transmitter	Plug in connector	Screwed, Cage clamp type	F
Thermocouple	Temperature transmitter	Plug in connector	Screwed, Cage clamp type	A,B,C*

Local Junction box, Temperature Transmitter, Int. Junction box of LIE/ LIR/Group JB/ MCC/SWGR	Group JB	Cage clamp (Rail mount) type.	Cage clamp (Rail mount) type.	F,G
Local Junction box, Temperature Transmitter, Int. Junction box of LIE/ LIR/Group JB/ MCC/SWGR	Marshalling Cubicle/ Marshalling Termination Cabinet cum	Cage clamp (Rail mount) type.	Posts mount cage clamp type.	F,G
Marshalling cubicle/ Termination Cabinet	Electronic system cabinet	Cage clamp Post mounted type.	Plug in connector/Other System as per manufacturer's Standard	Internal wiring
Marshalling/ Termination System Cabinets	UCD mounted equipments	Post mount cage clamp type.	Plug in connector/Cage clamp type (rail mounted).	F,G (with plug-in connector at one end)
DDCMIS/PLC cabinets	PC, Printers etc.	Plug in connector	Plug in connector	Mfr.'s Standard
Notes	<ol style="list-style-type: none"> 1. Normally 10% spare cores shall be provided when the numbers of pairs of cables are more than four pairs except for pre-fabricated cables which shall be as per manufacturer's standard. 2. For analog signals, individual pair shielding & overall shielding & for Binary signals, only overall shielding of instrumentation cables shall be provided. 3. Also refer Drg. 0000-110-POI-A-021. 4. *For high temperature applications only. 5. Instrument Cabling for instruments/equipments covered under subsection MAIN EQP INST SYS shall be as per manufacturer's standard . 			

6.00.00	TERMINAL BLOCKS
6.01.00	<p>All terminal blocks shall be rail mounted/post mounted, cage clamp type with high quality non-flammable insulating material of melamine suitable for working temperature of 105 deg. C. The terminal blocks in field mounted junction boxes, temperature transmitters, instrument enclosures/racks, etc., shall be suitable for cage clamp connections. The terminal blocks in Control Equipment Room logic/termination/marshalling cubicles shall be suitable for post mounted cage clamp connection at the field input end. The terminal blocks for DDCMIS input/output connections from/to SWGR/MCC, Actuators with Integral Starter (for coupling relays and check back signals of 11 kV and 3.3 kV auxiliaries, LT drives/valves & dampers/solenoids, CT & VT, etc.) shall be provided with built in test and disconnect facilities complete with plug, slide clamp, test socket etc. The exact type of terminal blocks to be provided by the Bidder and the technical details of the same including width etc. shall be subject to Employer's approval.</p>
6.02.00	<p>All the terminal blocks shall be provided complete with all required accessories including assembly rail, locking pin and section, end brackets, partitions, small partitions, test plug bolts and test plug (as specified above for SWGR connections) transparent covers, support brackets, distance sleeves, warning label, marking, etc.</p>
6.03.00	<p>The marking on terminal strips shall correspond to the terminal numbering on wiring diagrams. For terminals catering to Employer's supplied system requirement at least 20% spare unused terminals shall be provided everywhere including local junction boxes, instrument racks/enclosures etc.</p>
	<p>For terminals catering to contractor's supplied system requirement at least 10% spare unused terminals shall be provided everywhere including local junction boxes, instrument racks/enclosures termination/marshalling cabinets.</p>
	<p>All terminal blocks shall be numbered for identification and grouped according to the function. Engraved labels shall be provided on the terminal blocks</p>
6.04.00	<p>For terminating each process actuated switches, drive actuators, control valves, Thermocouple, RTD, etc. in Local Junction Boxes, etc, refer Drg no. 0000-999-POI-A-065.</p>
6.05.00	<p>The terminal blocks shall be arranged with at least 100 mm clearance between two sets of terminal blocks and between terminal blocks and junction box walls.</p>
6.06.00	<p>For ensuring proper connections, Bidder shall provide suitable accessories, along with insulation sleeves. The exact connecting accessory shall be finalised as per application during detail engineering stage subject to Employer's approval without any cost repercussions.</p>
6.07.00	<p>Internal wiring in factory pre-wired electronic equipment cabinets may be installed according to the Bidder's standard as to wire size and method of termination or internal equipment. Terminal blocks for connection of external circuits into factory</p>

		<p>prewired electronic equipment cabinets shall meet all the requirements as specified above.</p>
7.00.00	INTERNAL PANELS/ SYSTEM CABINETS WIRING	
7.01.00	Internal panel/cabinet wiring shall be of multi-stranded copper conductor with FRLS PVC insulation without shield and outer sheath meeting the requirements of VDE 0815.	
7.02.00	Wiring to door mounted devices shall be done by 19 strand copper wire provided with adequate loop lengths of hinge wire so that multiple door opening shall not cause fatigue breaking of the conductor.	
7.03.00	All internal wires shall be provided with tag and identification nos. etched on tightly fitted ferrules at both ends in Employer's approved format. All wires directly connected to trip devices shall be distinguished by one additional red colour ferrule.	
7.04.00	All external connection shall be made with one wire per termination point. Wires shall not be tapped or spliced between terminal points.	
7.05.00	All floor slots of desk/panels/cabinets used for cable entrance shall be provided with removable gasketed gland plates and sealing material. Split type grommets shall be used for prefabricated cables.	
7.06.00	All the special tools as may be required for solder less connections shall be provided by Bidder.	
7.07.00	Wire sizes to be utilised for internal wiring.	
	(i)	Current (4-20 mA), low voltage signals (48V); Ammeter/Voltmeter circuit, control switches etc. for electrical system. 0.5 Sq.mm.
	(ii)	Power supply and internal illumination. 2.5Sq.mm. minimum (shall be as per load requirement.)
8.00.00	INSTRUMENTATION CABLE INSTALLATION AND ROUTING	
8.01.00	All cables assigned to a particular duct/conduit shall be grouped and pulled in simultaneously using cable grips and suitable lubricants. Cables removed from one duct/conduit shall not be reused without approval of Employer.	
8.02.00	Cables shall be segregated as per IEEE Std.-422. In vertically stacked trays, the higher voltage cable shall be in higher position and instrumentation cable shall be in	

	<p>bottom tier of the tray stack. The distance between instrumentation cables and those of other system shall be as follows:</p>
	<p>From 11 kV/6.6 kV/3.3 kV tray system - 914 mm</p>
	<p>From 415V tray system - 610 mm</p>
	<p>From control cable tray system - 305 mm</p>
<p>8.03.00</p>	<p>Cables shall terminate in the enclosure through cable glands. All cable glands shall be properly gasketed. Fire proof sealing (to prevent ingress of dust entry and propagation of fire) shall be provided for all floor slots used for cable entrance. Compression cable glands (double for armoured and single for other cables) shall be provided.</p>
<p>8.04.00</p>	<p>All cables shall be identified by tag. Nos. provided in Employer's approved format at both the ends as well as at an interval of 5 meters.</p>
<p>8.05.00</p>	<p>Line voltage drop due to high resistance splices, terminal contacts, insulation resistance at terminal block, very long transmission line etc. shall be reduced as far as practicable.</p>
<p>8.06.00</p>	<p>The cables emanating from redundant equipment/devices shall be routed through different paths. The above segregation of cables & wiring for redundant equipments/devices shall be in accordance with IEEE-Std-422.</p>
<p>9.00.00</p>	<p>CABLE LAYING AND ACCESSORIES</p>
<p>9.01.00</p>	<p>CABLE LAYING</p>
<p>1</p>	<p>CABLES SHALL BE LAID STRICTLY IN LINE WITH CABLE SCHEDULE.</p>
<p>2</p>	<p>IDENTIFICATION TAGS FOR CABLES.</p>
<p>3</p>	<p>INDELIBLE TAGS TO BE PROVIDED AT ALL TERMINATIONS, ON BOTH SIDES OF WALL OR FLOOR CROSSING, ON EACH CONDUIT/DUCT/PIPE ENTRY/EXIT, AND AT EVERY 20 M IN CABLE TRENCH/TRAY.</p>
<p>3</p>	<p>CABLE TRAY NUMBERING AND MARKING.</p>
<p>4</p>	<p>TO BE PROVIDED AT EVERY 10M AND AT EACH END OF CABLE WAY & BRANCH CONNECTION.</p>
<p>4</p>	<p>JOINTS FOR LESS THAN 250 METERS RUN OF CABLE SHALL NOT BE PERMITTED.</p>

5 BURIED CABLE PROTECTION

WITH CONCRETE SLABS; ROUTE MARKERS AT EVERY 20 METERS ALONG THE ROUTE & AT EVERY BEND.

6 ROAD CROSSINGS

CABLES TO PASS THROUGH BURIED HIGH DENSITY PE PIPES ENCASED IN PCC. AT LEAST 300 MM CLEARANCE SHALL BE PROVIDED BETWEEN

- HT POWER & LT POWER CABLES,
- LT POWER & LT CONTROL CABLES
- LT CONTROL & INSTRUMENTATION CABLES,

SPACING BETWEEN CABLES OF SAME VOLTAGE GRADE SHALL BE IN ACCORDANCE WITH THE DERATING CRITERIA ADOPTED FOR CABLE SIZING.

7 SEGREGATION (PHYSICAL ISOLATION TO PREVENT FIRE JUMPING)

A ALL CABLE ASSOCIATED WITH THE UNIT SHALL BE SEGREGATED FROM CABLES OF OTHER UNITS.

B INTERPLANT CABLES OF STATION AUXILIARIES AND UNIT CRITICAL DRIVES SHALL BE SEGREGATED IN SUCH A WAY THAT NOT MORE THAN HALF OF THE DRIVES ARE LOST IN CASE OF SINGLE INCIDENT OF FIRE.

8 CABLE CLAMPING

All cables laid on trays shall be neatly dressed up & suitably clamped/tied to the tray. For cables in trefoil formation, trefoil clamps shall be provided.

9 Optical fiber cables inside conduit shall be laid on cable trays wherever available and feasible. In areas where the same are required to be buried, the same shall be buried in separate trench approx.1.6 meter depth, to be laid in 2" GI/rodent proof HDPE conduits covered with sand, brick and soil along the pipe line route;

While crossing roads - to be laid in GI/rodent proof HDPE conduits with sand filling at bottom and sand, soil filling at top with cement concrete;

While crossing canals/river- to be laid in GI/rodent proof HDPE conduits within hume pipe.

9.02.00	Bidder shall supply and install all cable accessories and fittings like Light Interface Units, Surge suppressors, Opto isolators, Interface Converters, Fibre Optic Card Cage, Fibre Optic Line Driver, Repeater / Modem (for Optical Fibre Cables), cable glands, grommets, lugs, termination kits etc. on as required basis.
9.03.00	Bidder shall furnish two completely new sets of cable termination kits like Crimping tools, etc., which are required for maintenance of the system as per the type of termination used.
9.04.00	Cables, which terminate in cabinets of draw out sections shall have sufficient cable coiled in the bottom of the cabinet to permit full withdrawal of draw out sections without disconnecting the cables. When prefabricated cables with factory connectors on both ends are longer than required, the excess cable shall be coiled in the bottom of one or both termination cabinets.
9.05.00	No splices shall be made in conductors for instrument and control circuits except where required at connections to devices equipped with factory installed pigtailed. Such splices shall be made only in approved splicing boxes of fitting with removable cover. The splices shall be made with sufficient slack left in the wires to permit withdrawal of the splice from the splicing box for ease of future disconnection of the splices. All exposed conductor or connector surfaces shall be covered with a minimum of three half-lapped layers of all weather vinyl plastic electrical tape. Taping shall extend a minimum of two cable diameters over the cable jacket and a similar distance over the other insulation or connections requiring insulation.
9.06.00	The Bidder shall be responsible for proper grounding of all equipment under C&I package. Further, proper termination of cable shields shall be verified and the grounding of the same shall be coordinated so as to achieve grounding of all instrumentation cable shields at same potential. This shall be completed prior to system tests. All the cables etc. required for grounding of all equipments supplied under this package are to be supplied by the Bidder.
9.07.00	The Contractor shall take full care while laying / installing cables as recommended by cable manufacturers regarding pulling tensions and cable bends. Cables damaged in any way during installation shall be replaced at the expense of the Contractor.
10.00.00	<p>FIELD MOUNTED LOCAL JUNCTION BOXES</p> <p>(i) No. of ways 12/24/36/48/64/72/96/128 with 20% spares terminals.</p> <p>(ii) Material and Thickness 4mm thick Fiberglass Reinforced Polyester (FRP).</p> <p>(iii) Type Door gasket shall be of synthetic rubber.</p>

	<ul style="list-style-type: none"> (iv) Mounting clamps and accessories Suitable for mounting on walls, columns, structures etc. The brackets, bolts, nuts, screws, glands and lugs required for erection shall be of brass, included in Bidders scope of supply. Raceways shall be provided inside JBs for proper termination of cables. (v) Type of terminal blocks Rail mounted cage-clamp type suitable for conductor size upto 2.5 mm². A M6 earthing stud shall be provided. (vi) Protection Class IP: 55 minimum for indoor & IP-65 minimum for outdoor applications. (vii) Grounding To be provided. (viii) Color To be decided during detailed engineering & subject to Employer's approval.
11.00.00	CONDUITS
11.01.00	<p>Conduits shall be generally used for interconnecting cables from field instruments to Local JB's. All rigid conduits, couplings and elbows shall be hot dipped galvanised rigid mild steel in accordance with IS: 9537 Part-I (1980) and Part-II (1981). The conduit interior and exterior surfaces shall have continuous zinc coating with an overcoat of transparent enamel lacker or zinc chromate. Flexible conduit shall be heat resistant lead coated steel, water leak, fire and rust proof. The temperature rating of flexible conduit shall be suitable for the following areas.</p> <ul style="list-style-type: none"> (i) Mills (ii) Drum (iii) Main steam, RH steam (iv) Air heater (v) Furnace, BFP DT's <p>And for remaining applications, water leak, fire & rust proof flexible G.I conduits shall be provided.</p>
11.02.00	The Bidder shall install conduits according to the general routing as approved by Employer and shall coordinate conduit locations with other works.
11.03.00	All grounding bushings within all enclosures shall be wired together and connected internally to the enclosure grounding lug or grounding bus with 8 AWG bare copper conductor. Conduit runs to individually mounted equipment shall be grounded to the Employer's cable tray grounding conductor with 12 AEG bare copper conductor. All

	grounding bushings, clamps and connectors shall be subject to approval of the Employer.
11.04.00	All rigid conduit fittings shall conform to the requirements of IS: 2667, 1976. Galvanized steel fitting shall be used with steel conduit. All flexible conduit fittings shall be liquid tight, galvanized steel. The end fittings shall be compatible with the flexible conduit supplied.
11.05.00	All individually mounted equipment and devices shall be connected to the supply conduit, using not more than one meter of flexible conduit adjacent to the equipment or device. Flexible conduit shall be installed in all conduit runs, which are supported by both building steel and structures subject to vibration or thermal expansion. This shall include locations where conduit supported by building steel enters or becomes supported by the turbine generator foundation and where conduit supported by building steel or foundation becomes supported by steam generator framing.
11.06.00	Special areas, such as control rooms in which external noise is to be minimized, shall have flexible conduit in conduit runs where the runs cross from the main building framing to the control room framing.
11.07.00	Conduit supports shall be furnished and installed in accordance with these specifications. Support material shall comply with the following requirements. <ul style="list-style-type: none"> i) Hanger rods shall be 12 mm diameter galvanized threaded steel rods. ii) Single conduit supports shall be one-hole cast metal straps and clamp backs unless other types are acceptable to the Employer. Multiple conduit bank supports shall be constructed of special galvanized support channels with associated conduit clips.
11.08.00	Conduit sealing, explosion proof, dust proof and other types of special fittings shall be provided as required by these specifications and shall be consistent with the area and equipment with which they are installed. Fittings installed outdoors and in damp locations shall be sealed and gasketed. Hazardous area fittings and conduits sealing shall conform to NEC requirements for the area classification.
11.09.00	Contractor shall provide double locknuts on all conduit terminations not provided with threaded hubs and couplings. Water tight conduit unions and rain tight conduit hubs shall be utilised for all the application which shall be exposed to weather. Moisture pockets shall be eliminated from conduits.
11.10.00	Conduits shall be securely fastened to all boxes and cabinets.
12.00.00	CABLE SUB-TRAY & SUPPORT
12.01.00	The cable sub-trays and the supporting system, to be generally used between Local/Group JB's and the main cable trays and the same shall be furnished and

	installed by the Contractor. It is the assembly of sections and associated fittings forming a rigid structural system used to support the cable from the equipment or instrument enclosure upto the main cable trays (trunk route).
12.02.00	The covers on the cable sub-trays shall be used for protection of cables in areas where damage may occur from falling objects, welding spark, corrosive environment, etc. & shall be electrically continuous and solidly grounded. The cable trays shall not have sharp edges, burrs or projections injurious to the insulation or outer sheath of the cables.
12.03.00	The supporting arrangement of cable tray system shall be able to withstand the weight of the cable and cable tray system. The supporting interval shall not be more than the recommended span for the above loading for the type of cable tray selected. The tray shall not overhang by more than one meter from the support at the dead end. As far as practicable the cable sub-tray system shall be supported from one side only, in order to facilitate installation and maintenance of cables.
12.04.00	The Bidder shall furnish and install the estimated quantities and sizes of sub trays/troughs including all required fittings and adaptors on as required basis.



**TECHNICAL SPECIFICATION FOR
HYDROGEN GENERATION PLANT
2 X 800 MW NTPC GADERWARA STPP STAGE-I**

SPEC NO.PE-TS-394-168-A001

VOLUME-IIB

SECTION

REV.NO.0

DATE

SHEET

TYPE TEST REQUIREMENTS

TYPE TEST REQUIREMENTS	
1.00.00	TYPE TEST REQUIREMENTS
1.01.00	General Requirements
1.01.01	<p>The Contractor shall furnish the type test reports of all type tests as per relevant standards and codes as well as other specific tests indicated in this specification. A list of such tests are given for various equipment in table titled 'TYPE TEST REQUIREMENT FOR C&I SYSTEMS' at the end of this chapter and under the item Special Requirement for Solid State Equipments/Systems. For the balance equipment instrument, type tests may be conducted as per manufactures standard or if required by relevant standard.</p> <p>(a) Out of the tests listed, the Bidder/ sub-vendor/ manufacturer is required to conduct certain type tests specifically for this contract (and witnessed by Employer or his authorized representative) even if the same had been conducted earlier, as clearly indicated subsequently against such tests.</p> <p>(b) For the rest, submission of type test results and certificate shall be acceptable provided.</p> <p style="padding-left: 40px;">i. The same has been carried out by the Bidder/ sub-vendor on exactly the same model /rating of equipment. (For control valves, this shall be same size, type & design).</p> <p style="padding-left: 40px;">ii. There has been no change in the components from the offered equipment & tested equipment.</p> <p style="padding-left: 40px;">iii. The test has been carried out as per the latest standards alongwith amendments as on the date of Bid opening.</p> <p>(c) In case the approved equipment is different from the one on which the type test had been conducted earlier or any of the above grounds, then the tests have to be repeated and the cost of such tests shall be borne by the Bidder/ sub-vendor within the quoted price and no extra cost will be payable by the Employer on this account.</p>
1.01.02	As mentioned against certain items, the test certificates for some of the items shall be reviewed and approved by the main Bidder or his authorized representative and the balance have to be approved by the Employer.
1.01.03	The schedule of conduction of type tests/ submission of reports shall be submitted and finalized during pre-award discussion.
1.01.04	For the type tests to be conducted, Contractor shall submit detailed test procedure for approval by Employer. This shall clearly specify test setup, instruments to be

1.01.05	<p>used, procedure, acceptance norms (wherever applicable), recording of different parameters, interval of recording precautions to be taken etc. for the tests to be carried out.</p> <p>The Bidder shall indicate in the relevant BPS schedule, the cost of the type test for each item only for which type tests are to be conducted specifically for this project. The cost shall only be payable after conduction of the respective type test in presence of authorize representative of Employer. If a test is waived off, then the cost shall not be payable.</p>
2.00.00	<p>SPECIAL REQUIREMENT FOR SOLID STATE EQUIPMENTS/ SYSTEMS</p>
2.01.00	<p>The minimum type test reports, over and above the requirements of above clause, which are to be submitted for each of the major C&I systems shall be as indicated below:</p> <ul style="list-style-type: none"> i) Surge Withstand Capability (SWC) for Solid State Equipments/ Systems <p>All solid state systems/ equipments shall be able to withstand the electrical noise and surges as encountered in actual service conditions and inherent in a power plant. All the solid state systems/ equipments shall be provided with all required protections that needs the surge withstand capability as defined in ANSI 37.90.1/ IEEE-472. Hence, all front end cards which receive external signals like Analog input & output modules, Binary input & output modules etc. including power supply, data highway, data links shall be provided with protections that meets the surge withstand capability as defined in ANSI 37.90.1/ IEEE-472. Complete details of the features incorporated in electronics systems to meet this requirement, the relevant tests carried out, the test certificates etc. shall be submitted along with the proposal. As an alternative to above, suitable class of EN 61000-4-12 which is equivalent to ANSI 37.90.1/ IEEE-472 may also be adopted for SWC test.</p> ii) Dry Heat test as per IEC-68-2-2 or equivalent. iii) Damp Heat test as per IEC-68-2-3 or equivalent. iv) Vibration test as per IEC-68-2-6 or equivalent. v) Electrostatic discharge tests as per EN 61000-4-2 or equivalent. vi) Radio frequency immunity test as per EN 61000-4-6 or equivalent. vii) Electromagnetic Field immunity as per EN 61000-4-3 or equivalent. <p>Test listed at item no. v, vi, vii, above are applicable for electronic cards only as defined under item (i) above.</p>

3.00.00

TYPE TEST REQUIREMENT FOR C&I SYSTEMS

Sl. No	Item	Test Requirement	Standard	Test To Be Specifically Conducted	NTPC's Approval Req. On Test Certificate
Col 1	Col 2	Col 3	Col 4	Col 5	Col 6
1	Elect. Metering instruments	As per standard (col 4)	IS-1248	No	Yes
2	Thermocouple	Degree of protection test	IS-2147	No	No
3	CJC Box	Degree of protection test	IS-2147	No	No
4	RTD	As per standard (col 4)	IEC-60751	No	No
5	Electronic transmitter	As per standard (col 4)	BS-6447 / IEC-60770	No	Yes
6	E/P converter	As per standard (col 4)	Mfr. standard	No	Yes
7	Instrumentation Cables Twisted & Shielded (Refer Note-B below)				
	-Conductor	Resistance test	VDE-0815	No	Yes
		Diameter test	IS-10810	No	Yes
		Tin Coating test (Persulphate test)	IS-8130	No	Yes
	-Insulation	Loss of	VDE 0472	No	Yes

		mass			
		Ageing in air ovens**	VDE 0472	No	Yes
		Tensile strength and elongation test before and after ageing**	VDE 0472	No	Yes
		Heat shock	VDE 0472	No	Yes
		Hot deformation	VDE 0472	No	Yes
		Shrinkage	VDE 0472	No	Yes
		Bleeding & blooming	IS-10810	No	Yes
	-Inner sheath***	Loss of mass	VDE 0472	No	Yes
		Heat shock	VDE 0472	No	Yes
		Cold bend/cold impact test	VDE 0472	No	Yes
		Hot deformation	VDE 0472	No	Yes
		Shrinkage	VDE 0472	No	Yes
	-Outer sheath	Loss of mass	VDE 0472	No	Yes
		Ageing in air ovens**	VDE 0472	No	Yes
		Tensile strength and elongation test before and after	VDE 0472	No	Yes

		ageing**			
		Heat shock	VDE 0472	No	Yes
		Hot deformation	VDE 0472	No	Yes
		Shrinkage	VDE 0472	No	Yes
		Bleeding & blooming	IS-10810	No	Yes
		Colour fastness to water	IS-5831	No	Yes
		Cold bend/ cold impact test	VDE-0472	No	Yes
		Oxygen index test	ASTMD-2863	No	Yes
		Smoke Density Test	ASTMD-2843	No	Yes
		Acid gas generation test	IEC-60754-1	No	Yes
	-fillers	Oxygen index test	ASTMD-2863	No	Yes
		Acid gas generation test	IEC-60754-1	No	Yes
	-AL-MYLAR shield	Continuity test		No	Yes
		Shield thickness		No	Yes
		Overlap test		No	Yes
	-Over all cable	Flammability Test	IEEE 383	No	Yes

		Swedish Chimney Test	SEN 4241475	No	Yes
		Noise interference	IEEE Transactions	No	Yes
		Dimensional checks	IS 10810	No	Yes
		Cross talk	VDE-0472	No	Yes
		Mutual capacitance	VDE-0472	No	Yes
		HV test	VDE-0815	No	Yes
		Drain wire continuity		No	Yes
	* For Drain wire only				
	**These tests shall be carried out as per VDE0207 Part 6 & ASTM D-2116 for TEFLON insulated & outer sheathed cables				
	***Applicable for armoured cables only				
8	DC Power Supply System The Type Test Reports for offered rectifier module and controller module irrespective of the rectifier bank rating shall be acceptable.				
		Degree of Protection	IS-13947 or equivalent	No	Yes
		Dry Heat Test	IEC-68-2-2 or equivalent	No	Yes
		Damp Heat test	IEC-68-2-3 or equivalent	No	Yes
		Vibration test	IEC68-2-6 or equivalent	No	Yes

		Electromagnetic field immunity	EN 61000-4-3 or equivalent	No	Yes
		Electrostatic discharge test	EN 61000-4-2 or equivalent	No	Yes
		Radio frequency immunity test	EN-61000-4-3 or equivalent	No	Yes
9	Battery (Refer Note-A below)	As per standard (col 4)	IS-10918	No	Yes
10	Voltage Stabiliser	Over Load Test	Approved procedure	No	Yes
		Temp rise test without redundant fans	Approved procedure	No	Yes
		Input voltage variation test	Approved procedure	No	Yes
11	DDCMIS				
	CLCS Systems	Model test	Approved procedure	No	No
	BMS	Safety requirements	VDE0116 Sec 8.7	No	Yes
12	Conductivity Type Level Switch	Degree of protection test	IS-2147	No	No
13	Local Gauges	Degree of protection test	IS-2147	No	No

14	Process actuated Switches	Degree of protection test	IS-2147	No	No
15	Control Valves	CV test	ISA 75.02	No	Yes
16	PLCs	As per standard (Col 4)	IEC 1131	No	No
17	LIE / LIR	Degree of protection test	IS-2147	No	Yes
18	Flue gas O2 analyser, other Flue Gas analysers	Degree of protection test	IS-2147	No	Yes
19	Flow Nozzles & Orifice plates	Calibration	ASME PTC BS 1042	No	Yes

Note:

Type Tests are to be conducted only for the items, which are being supplied as a part of this Package.

A. For batteries with electric power supply system of TG C&I, the contractor shall submit for Employer's approval the reports of all the type tests as per IS-10918 carried out within last five years from the date of bid opening and the tests should have been either conducted at an independent laboratory or should have been witnessed by a client. The complete type test reports shall be for any rating of battery in a particular group, based on plate dimensions being manufactured by supplier.

For batteries with electric power supply system of auxiliary plants, type test reports for batteries shall be as per standard practice of manufacturer.

B. All cables to be supplied shall be of type tested quality. The Contractor shall submit for Employer's approval the reports of all the type tests pertaining to cables as listed in this specification and carried out within last five years from the date of bid opening. These reports should be for the tests conducted on the cables similar to those proposed to be supplied under this contract and

the test(s) should have been either conducted at an independent laboratory or should have been witnessed by a client.

In case the Contractor is not able to submit report of the type test(s) for cables conducted within last five years from the date of bid opening, or in case the type test report(s) are not found to be meeting the specification requirements, the Contractor shall conduct all such tests under this contract free of cost to the Employer and submit the reports for approval.



**TECHNICAL SPECIFICATION FOR
HYDROGEN GENERATION PLANT
2 X 800 MW NTPC GADERWARA STPP STAGE-I**

SPEC NO. PE-TS-394-168-A001

VOLUME-IIB

SECTION

REV.NO.0

DATE

SHEET

PROCESS PIPING AND CONNECTION

PROCESS CONNECTION AND PIPING	
1.00.00	PROCESS CONNECTION PIPING
1.01.00	The Contractor shall provide, install and test all required material for completeness of Impulse Piping System and Air Piping System as per the requirements of this Sub-section, enclosed installation drawings and source connection drawings on as required basis for the connection of instruments and control equipment (provided by the Contractor) to the process / Employer's main equipment / systems. The installation & source connection of various items shall generally as per installation drawings (drawing no. 0000- 110 -POI-A-022 to 033, 0000- 110 -POI-A-034) and instrument source connection drawings (drawing nos. 0000-110 -POI-A -035), however, the Contractor shall furnish during detailed engineering. Installation drawings, GA and fabrication drawings of LIES / LIRs, other relevant drawings, material and tech data sheets of various items service wise for Employer's approval / information.
1.01.01	All materials, furnished under this sub-section and the installation thereof shall conform to the latest editions of American National Standard Code for Pressure Piping, Power Piping, ANSI B 31.1, ANSI B16.11, ASME Boiler and Pressure Vessel Codes, IBR and other applicable ASME, ANSI and state standards.
1.01.02	All materials supplied under this Sub-section shall be suitable for intended service, process; operating conditions and type of instruments used and shall fully conform to the requirements of this specification. The bidder is responsible for the performance of equipment furnished under this specification on system basis. The Bidder may offer suggestions for improvement based on his experience, during detailed engineering, which shall be subjected to the Employer's approval.
1.01.03	Contractor to note that any reducers, nipple etc. for proper connection of the impulse piping system to Employer's root valves / isolation valves / stubs etc. shall be in Contractor's scope only, unless otherwise clearly excluded.
1.02.00	IMPULSE PIPING, TUBING, FITTINGS, VALVES AND VALVE MANIFOLDS
1.02.01	All impulse pipe shall be of seamless type conforming to ANSI B36.10 for schedule numbers, sizes and dimensions etc. The material of the impulse pipe shall be same as that of main process pipe. For various applications specification of impulse pipe materials and associated fittings and valves shall be as given in Table PCP. For protection against sea environment, all impulse pipes, fittings etc shall be provided with durable epoxy coating with poly urethane finish.
1.02.02	Stainless steel tube shall be provided inside enclosures & racks from tee connection to valve manifold and then to instrument. For high pressure/temperature applications (piping class A,B,C & D of the table no. PCP) the material shall be ASTM A 213 TP

	<p>316H it and for other applications material shall be ASTM A 213 TP 316L. The wall thickness of the tube shall be in accordance with the ANSI B31.1 standard. The bending radius of the tube shall be greater than 6D.</p>
1.02.03	<p>All fittings shall be forged steel and shall conform to ANSI B16.11. The material of forged tube fittings for shaped application (e.g. Tee, elbow etc.) shall be ASTM A 182 Gr. 316 H for high pressure/ temperature applications (as defined above) and ASTM A 182 Gr. 316L for other applications. The material for bar stock tube fitting (for straight application) shall be 316 SS. Metal thickness in the fittings shall be adequate to provide actual bursting strength equal to or greater than those of the impulse pipe or SS tube, with which they are to be used.</p>
1.02.04	<p>The source shut-off (primary process root valve) and blow down valve shall be of 1/2 inch size globe valve type for all applications except for air and flue gas service wherein no source shut-off valves are to be provided. For various applications the valve body material, stem material and pressure class shall be as given in Table PCP. The end connections of valves shall be of socket welded type unless otherwise specified in the instrument installation diagrams The disc and seat ring materials of carbon steel and alloy steel valves be ASTM A-105 and ASTM A-182, Gr. F22, hard faced with stellite (minimum hardness - 350 BHN.) The surface finish of 16 RMS or greater is required in the area of stem packing. The valve design shall be such that the seats can be reconditioned and stem and disc may be replaced without removing the valve body from the line.</p>
1.02.05	<p>The valve manifolds shall be of 316 stainless steel with pressure rating suitable for intended application. 2-valve manifold and 3-valve manifold shall be used for pressure measurements using pressure transmitters/ pressure switches and differential pressure transmitter/ switches respectively. 5-valve manifold shall be used for remaining applications like DP, flow and level measurements.</p>
1.02.06	<p>For Pr./D.P gauges in fluid application two-way globe valve on each impulse line to the instrument and in Air / Flue gas application two-way gate valve on each impulse line to the instrument shall be provided near the instrument. These shall be in addition to the three ways gauge cock provided alongwith the pr./D.P gauges.</p>
2.00.00	AIR SUPPLY PIPING
2.01.00	<p>All pneumatic piping, fittings, valves, air filter cum regulator, purge Rotameter and other accessories required for instrument air for the various pneumatic devices/ instruments shall be provided. This will include as a minimum air supply to pneumatically operated control valves, actuators, instruments, continuous and intermittent purging requirements etc.</p>
2.02.00	<p>Instrument air supply shall be provided for continuous purging requirements of local instrument enclosures (LIEs) and any other instrument supplied by the Contractor</p>

<p>2.03.00</p> <p>2.04.00</p> <p>2.05.00</p> <p>2.06.00</p> <p>2.07.00</p>	<p>which requires instrument air. Also for intermittent purging requirements of local instrument enclosures (LIEs) all pipings, fittings valves etc. shall be provided for service air supply to LIEs housing air and flue gas transmitters. Service air supply shall also be provided for any other instrument supplied by the contractor requiring service air. The contractor shall also provide and connect pneumatic tubing to E/P convertors and then to control valves supplied by the Employer but controlled by the C&I Contractor.</p> <p>For individual supply line and control signal line to control valve, 1/4-inch size light drawn tempered copper tubing conforming to ASTM B75 shall be used. The thickness of cu-tubing shall not be less than 0.065 inch and shall be PVC coated. The fittings to be used with copper tubes shall be of cast brass, screwed type.</p> <p>All other air supply lines of 1/2 inch to 2 inch shall be of mild steel hot dipped galvanized inside and outside as per IS-1239, heavy duty with threaded ends. The threads shall be as per ASA B.2.1. Fittings material shall be of forged carbon steel A234 Gr. WPB galvanized inside and outside, screwed as per ASA B2.1. Dimensions of fittings shall be as per ASA B16.11 of rating 3000 lbs.</p> <p>The Employer shall provide instrument air at two points for the boiler area and one point for the turbine area at a convenient point for each unit. Similarly the Employer shall provide service air also at two points for the boiler area and one point for the turbine area at a convenient point for each unit. For air supply to various devices mentioned above, the contractor shall provide 2 inch size GI pipe header with isolation valve from the instrument air and service air terminal points. In the boiler area the 2 inch head shall be provided upto top most elevation of boiler floor and from this 2 inch header, 1 inch sub-header shall be branched off at each floor with isolation valve. From this 1 inch sub-header, branch line of 1/2 inch, with isolation valve shall be provided upto various devices. In the Turbine area the 2 inch head shall be provided upto top most elevation of Turbine floor and from this 2 inch header, 1 inch sub-header shall be branched off at each floor with isolation valve. From this 1 inch sub-header, branch line of 1/2 inch, with isolation valve shall be provided upto various devices. Similar system is to be followed for service air required for intermittent purging in the Local Instrument Enclosures (LIEs) etc.</p> <p>All instrument air filters cum regulator set with mounting accessories shall be provided for each pneumatic device requiring air supply. The filter regulators shall be suitable for 10-kg/ sq.cm max. Inlet pressure. The filter shall be of size 5 microns and of material sintered bronze. The air set shall have 2-inch size pressure gauge and built in filter housing blow down valve. The end connection shall be 1/4 inch / 1/2 inch / 3/4 inch NPT as per the requirement to be finalised during detailed engineering.</p> <p>All the isolation valves in the air supply line shall be gate valves as per ASTM B62 inside screw rising stem, screwed female ends as per ASA B2.1. Valve bonnet shall</p>

2.08.00	<p>be union type & trim material shall be stainless steel, body rating 150 pounds ASA. The valve sizes shall be ½ inch to 2 inch.</p> <p>Purge Air Connection for Air and Flue gas Applications</p> <p>The continuous purging with instrument air shall be done, for all air and flue gas measurements, at the process source connection end. Necessary arrangements required for continuous purging shall be provided inside all instrument enclosures and instrument racks for Air and Flue gas applications as per enclosed drawing no. 0000-999-POI-A-034.</p> <p>For intermittent purging with service air, necessary arrangements inside all the air and Flue gas enclosures shall be provided as per drawing no. 0000-110-POI-A-034. The SS four ways valve provided in the SS tubing shall be used for isolating the transmitter & connecting the service air quick disconnect line.</p> <p>Purging arrangement is not required for Instrument air and service air measurement applications.</p> <p>Purge air lines shall be of mild steel hot dipped galvanized inside and outside as per IS1239, heavy duty with threaded ends.</p>
3.00.00	<p>INSTALLATION AND ROUTING</p>
3.01.00	<p>All instrument piping, tubing and its accessories shall be supported in a safe manner to prevent excessive vibrations and anchored sufficiently to prevent undue strain on connected equipment. Instrument piping & tubing shall not be routed across equipment removal areas, above or below monorails, cranes, removable gratings, cable trays.</p>
3.02.00	<p>Instrument Piping System</p>
3.02.01	<p>For steam and liquid measurements, the impulse pipe should preferably slope downward from source connection to instrument and instrument shall be installed below the source point. If due to any reason instrument is installed above the source point, the impulse pipe should slope upwards continuously and a 'pigtail' should be provided at the instrument to assure water seal for temperature protection. For vacuum measurements instrument shall be installed above source point and impulse pipe should slope upwards.</p>
3.02.02	<p>Impulse piping for air and flue gas shall slope upwards and instrument shall be installed above source point. If this requirement cannot be met special venting or drain provision shall be provided with vent & drain lines alongwith isolation valves and other accessories including drainpipes. This drain is to be connected to plant drain through open funnel also. Horizontal runs must have a slope of not less than</p>

	40 mm per meter and must be adequately supported to maintain a constant slope and to prevent sag in piping.
3.02.03	All impulse piping shall be installed to permit free movement due to thermal expansion. Wherever required expansion loops shall be provided.
3.02.04	Special accessories such as condensing pots/ reservoirs shall be provided and installed wherever required. In any case condensing pots shall be provided for all level measurements in steam and water services, all flow measurement in steam services and flow measurements water services above 120 Deg. C. For drum level measurement required balancing chamber shall be provided and installed.
3.02.05	Colour coding of all impulse pipes shall be done by the Contractor in line with the colour coding being followed for the parent pipes.
3.03.00	Instrument Air & Service Air Piping/ Tubing System
3.03.01	The air supply headers, sub-headers and branch pipes shall be supported properly by clamps or supports to be provided and fabricated by the Contractor. Air supply piping shall be installed with a slope of over 1/100 to prevent accumulation of condensed water within the pipe. Signal/control air tubing shall run with the minimum number of changes in direction. Suitable identification tags shall be provided for easy link up and checking of proper connections. Single and multi tubes shall run with the minimum number of changes in direction. Suitable identification tags shall be provided for easy checkup and for connections.
4.00.00	PIPING/TUBING SUPPORT Impulse piping and sample piping shall be supported at an interval not exceeding 1.5 meters. Each pipe shall be supported individually using slotted angle mounted clamps with necessary fixtures. Tubing shall run in proper perforated trays with proper cover. Tubing shall be supported inside the trays by aluminium supports. Hangers and other fixtures required for support of piping and trays shall be provided, either by welding or by bolting on walls, ceilings and structures. Hanger clamps and other fastening hardware shall be of corrosion resistant metals and hot-dip galvanized.
5.00.00	SHOP AND SITE TESTS
5.01.00	General Requirements
5.01.01	The equipment and work performed as per this Sub-section shall be subject to shop and site test as per requirements of Sub-section-III E-04 (Quality Assurance & Inspection) other applicable clauses of this Sub-section and Employer approved quality assurance plan.

5.01.02	Hydrostatic and pneumatic tests shall be performed on all pipes, tubing and systems and shall conform to ANSI B31.1.
5.02.00	<p>Hydrostatic Testing</p> <p>All instrument piping/ tubing shall be hydrostatically tested upon completion of erection. The test pressure shall be 1.5 times the maximum process pressure. The test shall be performed either with the testing of associated process piping or without the associated process piping (by closing the root valve). In both the cases the instrument shall be isolated by closing the shut-off valve.</p>
5.02.00	<p>Air Testing</p> <p>All air headers & branch pipes shall be air tested by pressure decay method as per ANSI B31.1. Flexible hoses and short signal tubing shall be tested at normal pressure for leakage. Long signal tubing shall be tested by charging each tube with air at 2 kg/ sq. cm. through a bubbler sight glass. The boiler draft and vacuum piping shall be air tested by the same method as long signal tubing.</p>
6.00.00	<p>LOCAL INSTRUMENT ENCLOSURE AND RACKS</p> <div data-bbox="386 919 1419 1178" style="border: 1px solid black; padding: 5px;"> <p>The internal layout shall be such that the impulse piping/ blow down lines are accessible from back side of the enclosure / rack and the transmitters etc. are accessible from front side for easy maintenance. Bulkheads, especially designed to provide isolation from process line vibration shall be installed on instrument enclosures/racks to meet the process sensing line connection requirement.</p> <p>Vibration dampeners shall be installed for each enclosure / rack.</p> </div> <div data-bbox="386 1178 1419 1507" style="border: 1px solid black; padding: 5px;"> <p>The enclosures shall be constructed of 1.6 mm sheet plate and shall be of modular construction with one or more modules and two end assemblies bolted together to form an enclosure. Channel and frame shall be 3 mm thick. Double inter locking doors shall be provided. The doors shall be the three-point locking type constructed of not less than 1.6 mm thick steel. Doors shall have concealed quick removal type pinned hinges and locking handles. Door locks shall accept the same key.</p> <p>Gaskets shall be used between all mating sections to achieve protection class of IP-55.</p> </div> <div data-bbox="386 1507 1419 1772" style="border: 1px solid black; padding: 5px;"> <p>The instrument racks shall be free standing type constructed of suitable 3 mm thick channel frame of steel and shall be provided with a canopy to protect the equipment mounted in racks from falling objects, water etc. The canopy shall not be less than 3 mm thick steel, and extended beyond the ends of the rack. Bulk heads, especially designed to provide isolation from process line vibration shall be provided. Exact fabrication details shall be as finalised during detailed engineering stage. The junction box for racks also shall conform to IP 55 protection class.</p> </div>

Enclosures/racks shall be reinforced as required to ensure true surface and to provide adequate support for instruments and equipment mounted therein. Centre posts or any member which would reduce access shall not be provided.

Each transmitter enclosure housing instruments requiring **purge air** for continuous air purging, shall be provided with common purge air header, redundant air filter regulators of sufficient capacity, required pressure gauges, valves, fittings, SS tubings and individual purge meters for each purge line etc. as required and indicated in Instrument Installation drawings enclosed herewith.

A 15 mm NB **service air** header shall be furnished in each instrument enclosure housing air & flue gas and coal mill instruments. The header shall be furnished complete with a pressure regulating valve, pressure gauge, and quick disconnect connections. A hose for connecting each header to the draft instrument line four-way valves shall be furnished. The hose shall be self-storing nylon tubing having a burst pressure of 15 kg/sq.cm. The size of the hose shall be 1/2" minimum. The service air header shall originate at a bulkhead penetration or fitting located on one of the bulkhead plates.

The contractor shall prepare the piping drawings and the general arrangement layout drawings for each of the enclosures and racks. Special attention shall be given in the piping layout to avoid air traps in liquid filled piping or water pockets in piping intended to be dry. Drawings shall indicate the arrangement of all equipment, piping, valves and fittings within, the enclosure/racks and shall be subject to Employer's approval.

All liquid filled blow down lines, except those measuring vacuum shall be connected to a two inch header which is extended through one end of the enclosure and turned downward for directing the blow down into a drain. The material of the blow down header shall be carbon steel as per ASTM A 106 Gr C.

The Contractor shall submit to the Employer with his proposal a copy of his welding procedure specification together with proof of his compliance with the latest applicable welding ANSI code. Prior to any welding being performed, the Contractor shall submit the qualifications of the craftsmen who will perform the work.

TECHNICAL REQUIREMENTS

7.00.0 TABLE PCP

System/Line Description	Piping Class	Impulse Pipe Material	Schedule (Size)	Materials for Fitting/Valve Body	Valve Stem Material	Rating of Piping/ Fittings	Pr. Class of Valve
Main Steam/ Upstream of HP bypass and Auxiliary Steam Pressure reducing valve, Drum Level	A	ASTM-A335 Gr.P-91/22 (Note-2)	XXS (1/2 inch)	(Note-3)	(Note-3)	9000 lb	3000 SPL
BFP disch, superheater attemperator, spray to PRDS, Phosphate dozing pp disch, BCW pump	B	ASTM-A106 Gr. C	160 (1/2 inch)	ASTM-A105	ASTM-A-182 Gr.F6a	6000 lb	2500
Reheater attemperator	C	ASTM-A106 Gr. C	160 (1/2 inch)	ASTM-A105	-do-	6000 lb	1500
Hot Reheat/ down stream of Aux. Steam press. Reducing valve upto desuper heater/ Flash tank drain manifold, HP heater level.	D	ASTM-A335 Gr. P-91/22 (Note-2)	160 (1/2 inch)	ASTM-A182 Gr.F-22	(Note-3)	3000 lb	900
Cold reheat upto Tee-off for HP Bypass / Extraction steam to HPH	E	ASTM-A335 Gr.P-22	80 (1/2 inch)	ASTM-A182 Gr.F-22	ASTM-A-182 Gr.F6a	3000 lb	800
Cold reheat down steam of Tee-off (HP Bypass)	F	ASTM-A106 Gr. C	80 (1/2 inch)	ASTM-A105	-do-	3000 lb	800
BFP suction, Condensate System/ Extraction to LPH/ Ext-4 to BFPT, Deaerator/ auxiliary steam, service air, inst air, ECW pump, ACW pump and other low pr water services	G	ASTM-A106 Gr. B	80 (1/2 inch)	ASTM-A105	-do-	3000 lb	800
Air/ Flue gas outside furnace	M	ASTM-A106 Gr. B/C	80 (3/4 inch)	ASTM-A105	-do-	3000 lb	800
Air/ Flue gas inside furnace	N	ASTM-A335 Gr.P22	80 (3/4 inch)	ASTM-A182 Gr. F-22	-do-	3000 lb	800
NOTE:							
1	Rating of piping/fittings/valves etc. is subjected to the final design pressure & temperature during the detailed engineering.						
2	In case temperature is more than 540 deg C, the material shall be P-91 only.						
3	Material shall be compatible with that of the impulse pipe material and design parameter.						
4	Separator related impulse piping material shall be as per main process pipe/tank material						