



BHARAT HEAVY ELECTRICALS LIMITED
HEEP HARIDWAR INDIA-PIN 249403
FAX NO: 0091 1334 226462
PHONE NO: 0091 1334 281561

Enq. No.: **T/3991/2014/2079/D1**

Date of issue : 10/10/2014

M/S.....

Sub: BHEL-HEEP/OPEN-TENDER (COMPONENT)/2014

Dear Sir,

The Heavy Electricals Equipment Plant (HEEP) located in Haridwar, India is one of the major manufacturing plants of Bharat Heavy Electricals Ltd. The core business of HEEP includes design and manufacture of large steam and gas turbines, turbo generators and so on.

Sealed tenders with the Tender No. and opening date clearly super scribed on the cover are invited from the manufacturers (registered as well as unregistered) for the supply of the following items:-

Sl. No.	Tender No.	Description of Item	Qty.	Opening Date
1	T/3991/2014/2079/D1	ZZST57613010 SUPPLY AND ESTABLISHMENT OF PROCESS, FIXTURES, TOOLS, CNC PROGRAMS FOR THE MACHINING OF Z SHROUD OF FIR TREE BLADE ON 5 AXIS MACHINE AS PER PIR TDC- M-ST-12-576-HW	01 NO.	10.11.2014

The details with required delivery are given in **Annexure-1**.

The tender documents can be down loaded from our web site www.bhel.com or www.bhelhwr.co.in or www.tenders.gov.in or <http://eprocure.gov.in> submitted with requisite EMD and tender fees. As per notification reference no. NSIC/HO/GP/15(4)/2013-14 dated 07.07.2013 Micro & Small Enterprises (MSEs) will be issued tender sets free of cost. A certificate issued from competent authority shall be submitted in support of Micro & Small Enterprises (MSEs).

This notification shall be published in Indian Newspaper. **The date for opening of tender shall be 10.11.2014.** Tenders will be received in tender box kept at Main ADM building, HEEP – BHEL, Ranipur Haridwar – 249403 Uttarakhand (India) up to 1.45 P.M. on **10.11.2014** and opened on the same day at 2.00 P.M. in the Tender Room. **Please note that tender received after due date & time (1.45PM on 10.11.2014) will not be REPEAT will not be opened.** BHEL will not be responsible for any type of postal / courier delay.

Intending vendors must remit the **tender fee of Rs. 2,000/-** for indigenous vendors (or equivalent amount in foreign currency for foreign vendors) against each tender along with the requisite **EMD Rs 1,50,000.00/-** (Rupees One Lakh Fifty Thousand) in the form of bank draft while submitting the tender documents as detailed in “Instruction to Bidders”, after down loading from this web site. As per notification reference no. NSIC/HO/GP/15(4)/2013-14 dated 07.07.2013 Micro & Small Enterprises (MSEs) are exempted from payment of EMD.

Specifications & Drawing of the above items are available on our above website with links provided for all Specifications, Drawings & Annexure (At the end of this document). Amendments/Corrigendum, if any, will be hosted on our web site only. Other terms and conditions will be as per tender documents.

Please submit your Techno-Commercial offer only for the above requirement subject to our terms and conditions, else your offer will be rejected.

The tender document must comprise of tow envelops:

1. Envelop I: Techno- Commercial Bid +Supplier Registration Form (Annexure 4 for Foreign vendor and Annexure 5 for Indian vendors) + EMD & Tender fee or NSIC certificate for exemption of tender fee.

2. Envelop II: Price Bid.

VENDORS HAVE TO SUBMIT EMD AND TENDER FEE [PLEASE SUBMIT SEPARATE DRAFT FOR EMD AND TENDER FEE. DRAFTS SHALL BE DRAWN IN FAVOUR OF BHEL, HARIDWAR IN SEPARATE ENVELOPE SUPERSCRIBED WITH BOLD LETTERS “EMD & TENDER FEE”. BIDS shall be opened at 2 PM on the due date in the presence of authorized representative of the bidders who may like to be present. The authorized representative should bring authority letter from their parent company (Manufacturer) for attending the bid opening.

KINDLY READ “INSTRUCTIONS TO BIDDERS.” QUOTATION NOT IN ACCORDANCE WITH THE INSTRUCTIONS ARE LIABLE TO BE DISQUALIFIED AND IGNORED.

INSTRUCTIONS TO BIDDERS FOR OPEN TENDER

1.0 DEFINITION

Registered Vendors - Are those who are registered with BHEL, Haridwar for Megawatt rating/ Size/ Weight of tendered components in respective material grade or machining of such items.

Un-registered Vendors - Are those who are not registered with BHEL, Haridwar for Megawatt rating/ Size/ Weight of tendered components in respective material grade or machining of such items.

2.0 TECHNICAL QUALIFICATION

- Enclosed format – Annexure-2 to be submitted. It is the mandatory requirement. Offer of Vendors not meeting these requirements may not be considered.

3.0 ESSENTIAL INSTRUCTIONS

1. Only those bids may be opened which have been submitted with requisite EMD & tender fee (if any).
2. All un-registered vendors may be approved by BHEL, if found suitable, on the basis of data furnished by them in Supplier Registration Form (SRF) Foreign Vendors or Indigenous Vendors (as applicable). Vendor (s) shall not be considered for ordering if not approved by BHEL.
3. BHEL team may visit the vendor (s) works for verification of capability and capacity claimed in tender documents/offer (s).
4. The tenders shall be submitted in two parts in separate sub-envelops clearly super scribing type of bid, tender no., due date and the name of vendor with full contact details as described below on or before the due date. Vendor Registration Form shall be submitted by unregistered vendors only.

- i. Part I - Techno -Commercial Bid + Vendor Registration Form + EMD & Tender fee or NSIC certificate for exemption of tender fee.
- ii. Part II - Price Bid.

All the two sub-envelops to be put in a single covering envelop indicating tender no., due date and the name of vendor with full contact details.

5. Clearly state your status regarding Micro, Small and Medium Enterprises as per the Micro, Small and Medium Enterprises Development Act-2006 by producing relevant certificate. MSE Suppliers can avail the intended benefits only if they submit along with offer, attested copies of either EM II certificate having deemed validity (Two years from the date of issue of acknowledgement in EM II) or valid NSIC certificate or EM II certificate along with CA certificate applicable for the year certifying quantum of investment in plant & machinery within the permissible limit as per the act for relevant status (Micro or small) where the deemed validity of EM II is over. Date to be reckoned for determining the deemed validity will be the last date of technical bid submission. Non submission of such documents will lead to consideration of their bids at par with other bidders and MSE status of such suppliers shall be shifted to Non MSE supplier till the supplier submits these documents.
6. The Quotation should be from the Principal / Original Manufacturer, failing which the quotation is likely to be ignored. In Case the quotation is submitted through agent, the quotation must accompany specific authorization letter from the principal.
7. Any corrections / amendments shall be properly & fully authenticated with signature. No overwriting is acceptable.
8. Compliance of technical/ commercial terms and conditions as per Annexure-3
9. Part- I (Techno -Commercial Bid + Vendor Registration Form + EMD & Tender fee or NSIC certificate for exemption of tender fee.) will be opened on the date and time specified in the tender notice in the presence of those vendors who wish to attend.
10. Part-II (Price Bids) along with supplementary price bids, if necessary, will be opened at a later date of only those bidders whose Part I bid has been found acceptable.
11. Delivery schedule is as per our requirement. However, vendor to quote best possible lead time from the date of placement of purchase order. Offers of those vendors may not be considered if it is not found suitable to BHEL requirement.
12. Currency exchange rate will be applicable on the date of opening of Techno-commercial Bid for evaluation purpose.
13. BHEL reserves the right to split order on more than one vendor.
14. BHEL reserves the right to increase or decrease the tender quantities. Vendor should be prepared to accept order for reduced quantity without any extra charges. Vendor should also be prepared for giving quantity discount in case of increase in quantity.

15. BHEL reserves the right to reject any of all the quotations without assigning any reason thereof and no representation shall be entertained in this regard.
16. The bid shall be evaluated on landed cost to BHEL basis.
17. Tenders when finalized shall be in the name of the bidder only and change of name during tender evaluation (without certificate from registrar of company) and after submission of the tender is liable to make the offer ineligible for participation.
18. All test certificates / Guarantee certificates to be submitted in TRIPLICATE along with dispatch documents.
19. BHEL reserves the right to open the price bid (part-II) along with the opening of techno-commercial offer at its option and in that case vendor will be informed accordingly.
20. BHEL reserves the right to go for reverse auction. Vendors are requested to give their best price. In case of failure of reverse auction the paper bid shall be processed. Bidder should clearly indicate their acceptance for reverse auctioning in Annexure-3. The bids of those vendors who do not agree for reverse auction may not be considered.
21. Total weight -- /Gross / Net in Kg. & also package size essentially should be indicated if not exact then approximate.
22. BHEL will evaluate the technical bids against essential criteria/requirements. BHEL may seek clarifications, if required, from the qualified bidders only. These clarifications will be communicated to the eligible vendors. The offers of those bidders, who are unable to respond in specified time frame, are likely to be ignored.
23. SETTLEMENT OF DISPUTES
 - Indigenous Vendors: In all cases of dispute the matter shall be referred for arbitration to any arbitrator to be appointed by the Executive Director or any officer who is the administrative head of Bharat Heavy Electricals Ltd., at Haridwar. The venue of arbitration shall invariably be Ranipur Haridwar. The award of the arbitrator shall be final and binding on both the parties. The arbitrator shall have the power to extend, from time to time, the time for making his award with the consent of the parties.
 - Foreign Vendors: In the event of any dispute or difference arising between the parties to this contract regarding execution of same or their respective rights and liabilities there under, the same shall except as otherwise expressly provided therein, be referred to the arbitration of the two arbitrators, one to be appointed by each party; or in the case of the said arbitrators not agreeing then an umpire to be appointed by the two arbitrators in writing before entering on that reference and provisions of the Indian Arbitration Act ,1940 or any statutory notification, or re-enactment therefore and rules framed there under from time to time shall apply to such arbitration . If the two arbitrators do not agree on the appointment of umpire, the nomination of the umpire shall be done by the International Chamber of Commerce, Paris(France).The decision of arbitrators, or in case of their not agreeing, that of the said umpire shall be binding both on seller and purchaser. The venue of the arbitration invariably be New Delhi.
24. JURISDICTION

All question, dispute or differences arising under, out of or in connection with the purchase order shall be subject to the exclusive jurisdiction of Haridwar courts.
25. OVER RIDING CLAUSE

All stipulations made in any correspondence other than those exchanged in regards to “instruction” in our tender documents / enquiry for submission of your offer, if at all shall be void to the extent they are repugnant to the conditions contained herein above and in the purchase order.
26. FINALITY OF MANAGEMENT DECISION

At all places in the preceding clauses BHEL Management’s decision shall be final.

4.0 GENERAL INSTRUCTIONS

PART-I (TECHNO-COMMERCIAL BID) shall comprise of following documents:

- a. Annexure-2 for Pre-qualification requirement.
- b. Annexure-3 for compliance of technical/ commercial terms and conditions.
- c. Annexure-4 or 5 for un-registered vendors and sub-vendors both.
- d. Complete technical offer as per specification, drawings, technical requirement along with un-priced bid indicating FOB / FCA only separate Lloyd’s/BV/TUV inspection charges (for Foreign vendors) and delivery schedule.
- e. Validity of offer to be indicated.
- f. Deviation with reference to specification/drawing, if any, should be clearly indicated on a separate sheet.
- g. Non disclosure agreement as per Annexure 6. The agreement shall be duly stamped & signed.

- h. Any additional documents.
- i. Separate drafts of EMD & Tender fee or NSIC certificate for exemption of tender fee (if any).
- j. Vendor Registration Form (SRF)
(Annexure-4 for Foreign Vendors & Annexure-5 for Indigenous Vendors)
The SRF duly filled up will be assessed for manufacturing capability quality systems being followed, organizational soundness and financial worthiness. The same shall be submitted with Part-I (Techno-Commercial Bid) by un-registered vendor only with BHEL, HEEP, Haridwar.

PART –II (Price Bid)

- a. Price bid with prices to be submitted as part-II of the tender.
- b. In case of foreign vendors, prices to be quoted on FOB / FCA only.
Loading port must be mentioned.
- c. In case of foreign vendors, third party (Lloyd's/BV/TUV) inspection charges to be quoted separately as third party inspection (Lloyd's/BV/TUV) is in vendor's scope. For Indian vendors, inspection shall be by BHEL nominated inspection agency. Prices shall be loaded by 0.18% on account of BHEL nominated inspection agency inspection charges. Third Party inspection shall be in BHEL scope.
- d. In case of Indigenous vendor, prices must be quoted on F OR-Destination-CPS-HEEP-BHEL basis. Goods shall be dispatched through any Indian Bank Association approved transporters having their branch at Hardwar/ destination. For convenience the names and addresses of transporters approved by IBA & BHEL are posted at our website <http://www.bhelhwr.co.in>.
- e. Prices should remain firm till the execution of the order.
- f. Insurance shall be taken care by BHEL.
- g. **Prices are to be written in both Figures & Words. In case of any difference between the two, If there is a discrepancy between words and figures, the amount in words shall prevail.**
- h. **LD Penalty shall be applicable at the rate of ½% (half percent) per week or part thereof subject to a maximum of 10% of the value of delayed portion of the order. In case of any variation in LD penalty acceptance, your prices shall be loaded to the extent LD penalty not accepted by you.**
- i. Payment term shall be “100% payment against dispatch documents, through irrevocable LC (for foreign vendors) and through bank (for indigenous vendors)” and bank charges shall be either side. **BHEL as a rule do not agree to release advance payment.**
- j. Irrevocable LC is opened for one quarter (3 months) & is established 30 days prior to delivery schedule. The charges of establishing the LC are on either side i.e. charges in India to be borne by BHEL and charges outside of India to be borne by vendor. If any vendor insists for LC for more than one quarter, vendor has to essentially bear all charges (Within & Outside India) for the period exceeding one quarter.
- k. **BHEL does not open confirmed LC even if vendor agrees to bear the confirmation charges.**

IN CASE YOU ARE NOT MAKING AN OFFER AGAINST THIS ENQUIRY, THEN PLEASE ARRANGE TO SEND A LETTER OF REGRET IF YOU HAVE COLLECTED THE TENDER DOCUMENTS FROM BHEL.

TERMS AND CONDITIONS OF REVERSE AUCTIONING

Against this enquiry for the subject item /system with detailed scope of supply as per enquiry specifications, BHEL may resort to “REVERSE AUCTION PROCEDURE” i.e., ON LINE BIDDING ON INTERNET.

- For the proposed reverse auction, technically and commercially acceptable bidders only shall be eligible to participate.
- BHEL will engage the services of a service provider who will provide all necessary training and assistance before commencement of on-line bidding on internet.
- BHEL will inform the vendor in writing in case of reverse auction, the details of Service Provider to enable them to contact & get trained.
- Business rules like event date, time, start price, bid decrement, extensions etc. also will be communicated through service provider for compliance.
- Vendors have to fax the Compliance form in the prescribed format (provided by Service provider) before start of Reverse auction. Without this, the vendor will not be eligible to participate in the event.
- BHEL will provide the calculation sheet (e.g., EXCEL sheet) which will help to arrive at “Total Cost to BHEL” like Packing & forwarding charges, Taxes and Duties, Freight charges, Insurance, Service Tax for Services and loading factors (for non-compliance to BHEL standard Commercial terms & conditions) for each of the vendor to enable them to fill-in the price and keep it ready for keying in during the Auction.
- Reverse auction will be conducted on scheduled date & time.
- At the end of Reverse Auction event, the lowest bidder value will be known on the network.
- The lowest bidder has to Fax the duly signed Filled-in prescribed format as provided on case-to-case basis to BHEL through Service provider within 24 hours of Auction without fail.
- Any variation between the on-line bid value and the signed document will be considered as sabotaging the tender process and will invite disqualification of vendor to conduct business with BHEL as per prevailing procedure.
- In case BHEL decides not to go for Reverse Auction procedure for this tender enquiry, the Price bids and price impacts, if any, already submitted and available with BHEL shall be opened as per BHEL’s standard practice.

Annexure- 1

Sl. No.	Tender No.	Description of Item	Delivery required	Qty.
1	T/3991/2014/2079/D1	<u>ZZST57613010</u> SUPPLY AND ESTABLISHMENT OF PROCESS, FIXTURES, TOOLS, CNC PROGRAMS FOR THE MACHINING OF Z SHROUD OF FIR TREE BLADE ON 5 AXIS MACHINE AS PER PIR TDC- M-ST-12-576-HW	01 NO.- 19/01/2015	01 NO.

- Delivery dates are tentative, However vendor should quote best delivery.

ANNEXURE-2

ANNEXURE- 01

Pre-Qualifying Requirements for Indent

1.0	QUALIFYING CRITERIA	Required	Remarks
1.1	The vendors, who have worked on 'TurboSoft CAM Software' of M/S Liechti, Switzerland or similar type of CAM software for development of CNC programs for blade machining and also successfully established it on CNC 5 Axis machining centre in the last 10 years, should respond.	Vendor to accept & confirm	
1.2	Name of the customer / company where above mentioned work has been established.	Vendor to inform	
1.3	Complete postal address of the customer.	Vendor to inform	
1.4	Month & Year of successful establishment of blade machining on CNC 5 axis machining centre.	Vendor to inform	
1.5	Name and designation of the contact person of the customer.	Vendor to inform	
1.6	Phone, FAX no. and email address of the contact person of the customer.	Vendor to inform	
1.7	Details of machine(major specification), CAM software used, details of blade successfully established on the mentioned machine.	Vendor to submit	
1.8	Performance certificate from the customers regarding successful establishment of blade programs using CAM software (Original Certificate or Through E-mail directly from the customer). The original performance certificate may be returned after verification by BHEL, if required.	Vendor to submit	
1.9	BHEL reserves the right to verify the information provided by vendor. In case the information provided by vendor is found to be false/incorrect, the offer shall be rejected	Vendor to accept & confirm	

Anil Kumar

**Anil Kumar
E1 (NBS)**

Rajiv Kumar Rajak

**Rajiv Kumar Rajak
Mgr. (TBM)**

D.K. Chawla

**D.K. Chawla
SDGM(NCT)**

ANNEXURE-2

TECHNICAL DELIVERY CONDITION

SL. NO.	DESCRIPTION OF BHEL REQUIREMENT	REQUIRED	OFFERED	DEVIATION	REMARKS
1.0	SCOPE Supply and Successful Establishment of Process, Fixtures, Toolings, CNC Programs for the complete finish machining of Z shroud (as per Section M, Section F-F, Section B-B & Section D-D including shroud fillet, shroud platform) and roughing of seal strip of Firtree blade (Drq. No 01030756001 / 01030756003) as per drawing accuracy & finish on existing CNC 5 Axis Machining center(TM 1200g) of M/s Liechti make.				
1.1	FIXTURES				
1.1.1	Fixture for holding Fir-Tree Root of blade compatible to the headstock of existing CNC 5 Axis Machining center(TM 1200g) of M/s Liechti make (Schematic diagram of headstock as per Annexure-3 and Blade Root as per enclosed drawing No. 21030741031).	Vendor to Confirm			
1.1.2	Fixture for holding Z Shroud end of blade compatible to the tailstock of existing CNC 5 Axis Machining center(TM 1200g) of M/s Liechti make (Schematic diagram of tailstock as per Annexure-3).	Vendor to Confirm			
1.1.3	Any other accessories required for successful machining as per scope of work (Clause No. 1.0) shall have to be supplied by the vendor.	Vendor to Confirm			
1.2	GENERATION OF CNC PROGRAMS Vendor shall generate the model/tool path and CNC programs through a Automation system based on existing CAM Software 'Turbosoft' or any other similar software and provide all necessary customization required in the software for automatic generation of model/toolpath and CNC program for these type of blades. The Automated system should be capable of parametrically defining blade shroud details and other details required for machining as per scope of work (clause No 1.0) and thereafter automatic generation of required model, toolpath and CNC Programs for existing CNC 5 Axis Machining center (TM 1200g) of M/s Liechti make. All softwares, automation & customization other than existing CAM Software 'Turbosoft' required for above automatic generation of model, toolpath and CNC Programs shall form part of scope of supply for machining of similar blades in future.	Vendor to Confirm			
1.3	TIME CYCLE Vendor to submit time cycle for machining as per PROVEOUT mentioned at Clause no. 1.4.1 The time cycle should include job change time, tool change time, machining time, In-process probing (if any) and post process probing of Z shroud dimensions.	Vendor to Submit			
1.4	PROVE OUT Drawings of proveout component is enclosed. Successful finish machining of Complete Z Shroud (details as per Section M, Section F-F, Section B-B and Section D-D including shroud fillet, shroud platform) and roughing of seal strip of Firtree blade, Drq. No. 01030756001(Left Hand) and 01030756003 (Right Hand) to the specified design accuracy and surface finish, shall be done by the vendor using supplied tools, Fixtures and CNC programs (generated through Automation system based on CAM Software 'Turbosoft' or any other similar software as per clause no. 1.2) on already existing CNC 5 Axis single Spindle Machining Cell (TM 1200G of M/s Liechti make) at BHEL, Haridwar in New Blade shop. Representative of vendor shall have to carryout machining of 20 nos. (10 Left Hand + 10 Right Hand) and time study submitted as per point number 1.3 shall have to be established. Raw forged blade with finished machined Fir Tree Root (drg. no.21030741031) & Blade Profile (drg. no. 01030756021) as per forging drawing no. 1030756998 shall be provided by BHEL. (Total 20 blades to be proved during final acceptance at BHEL works).	Vendor to Confirm			

Signature 
 Name- Anil kumar
 Designation- E1
 Dept. - TBM NBS

Signature 
 Name-R. K. Rajak
 Designation- Mgr
 Dept. - TBM NBS

Signature 
 Name - DK Chawla
 Designation-SDGM
 Department- NCT

ANNEXURE-2

SL. NO.	DESCRIPTION OF BHEL REQUIREMENT	Vendor to Confirm
1.4.2	Vendor shall be responsible for any deviation/rejection in proveout component due to wrong machining or malfunctioning of the machine during proveout machining and also for the delay in machining due to improper recommended tooling etc.	Vendor to Confirm
1.5	TOOLINGS Vendor to submit complete list of toolings with itemwise price. The toolings shall consist of all consumables, tool holders, cutter bodies, keys/wrench etc. for above mentioned machining of 20 blades (as per Proveout clause no. 1.4.1). The tooling shall consist of 2 Nos. of tool holders & cutter bodies (considering sister tooling concept) for each variety of cutting tools used for machining the above mentioned blades. The toolings should be sufficient to machine the quantity of blades mentioned under Proveout (clause no. 1.4.1). Detailed drawing /catalogue of all the toolings are to be supplied in the event of order. No resharping or recoating should be considered in the offered toolings.	Vendor to Confirm
1.5.1	Any change in tooling/tool holder or requirement of more numbers of cutting tools during proveout shall be at the responsibility and cost of the vendor and the same shall be supplied in sufficient quantity as mentioned above and under the heading of 'Toolings'.	Vendor to Confirm
1.5.2	DOCUMENTS Vendor to submit complete manufacturing drawing of supplied Fixtures for A-axis (Master and Slave) as per clause no. 1.1 including name of supplier for standard parts used if any.	Vendor to Confirm
2.0	FINAL ACCEPTANCE Final acceptance shall be made by BHEL Hardwar after completion of all activities mentioned at clause no. 1.1, 1.2, 1.4, 1.5 and 2.0	Vendor to Confirm
3.0	GENERAL INFORMATION All the information and drawings attached with tender document are exclusive property of BHEL Hardwar. Under no circumstances these should be passed to any third party without prior permission of BHEL and must not be used directly or indirectly detrimental to the interest of BHEL.	Vendor to Confirm
3.1	Major specifications of CNC 5 Axis Machining center(TM 1200g) of M/s Liechti make are enclosed at Annexure-04	Vendor to Confirm
4.0		
4.1		
4.2		

Signature 
 Name - DK Chawla
 Designation-SDGM
 Department- NCT

Signature 
 Name-R. K. Rajak
 Designation- Mgr
 Dept.- TBM NBS

Signature 
 Name- Anil kumar
 Designation- E1
 Dept.- TBM NBS

ANNEXURE-2

ANNEXURE-3

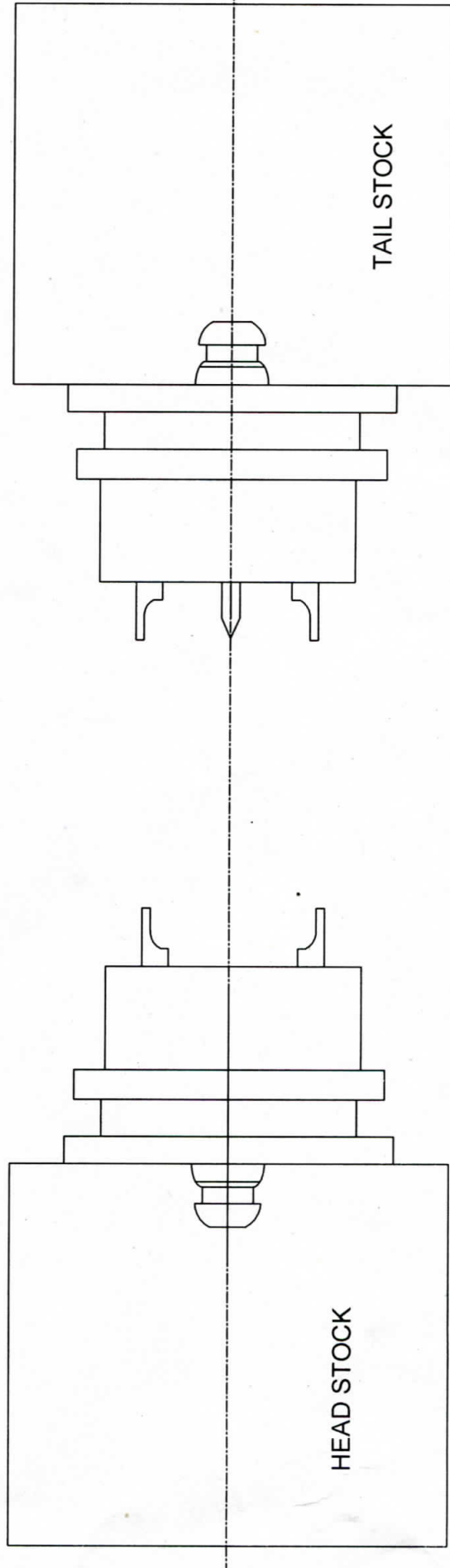
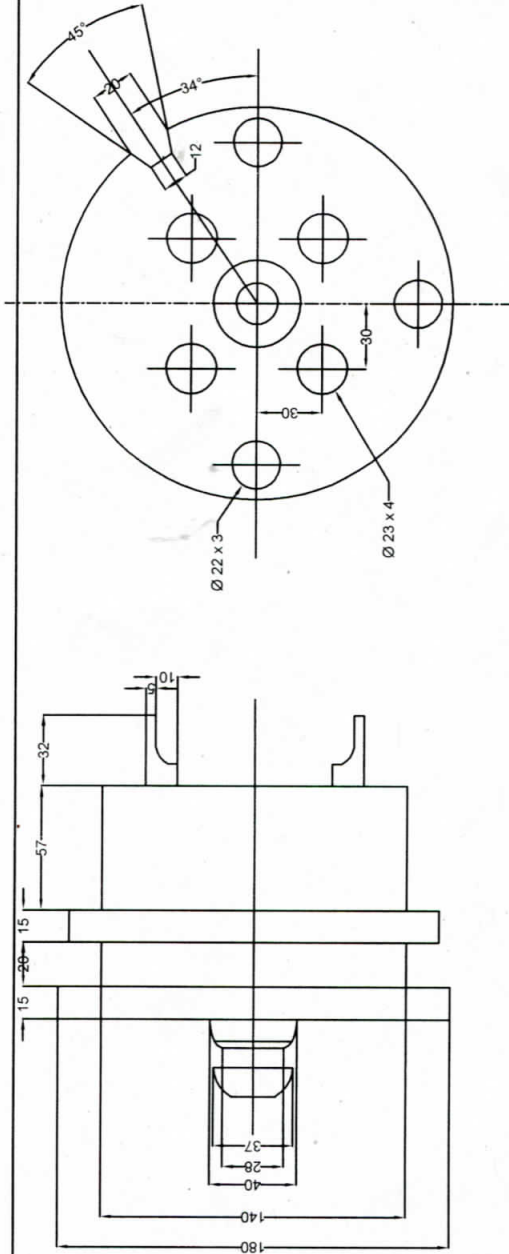

SCHEMATIC DIAGRAM OF PART OF HEAD STOCK AND TAIL STOCK TO HOLD THE FIXTURE FOR FIR TREE ROOT AND SHROUD RESPECTIVELY.

[Handwritten signature]
(E1, TBM-MEB)

ANEEXURE-2

Refe. Indent no 20142079

Annexure -04

Broad specification of 5 axis single spindle Liechti machine Model TM1200 g		
Sr. No.	Description	VALUES
1	Longitudinal X axis	1800 mm
2	Max. job clamping length excluding adaptor/chuck (X axis)	1000 mm
3	Max. job holding capacity(Including Fixture)	100 Kg
4	Vertical Axis Y	450 mm
5	Transverse Axis Z	550 mm
6	Feeds & Rapid Traverses of X,Y & Z Axis	50 m/min
7	Rotary A axis	360 Deg.
8	A axis rotaion	200 rpm
9	A axis Swing Diameter with Job	Dia 400
10	Swivel Spindle - B axis	B=+50°-50°
11	Spindle motor make	M/s Fischer
12	Spindle diameter	280 mm
13	Spindle Speed	16000 RPM
14	Spindle Power(S1)	28 KW
15	Spindle Torque	200 Nm
16	Spindle Taper	HSK 63A
18	Synchronization of head stock and tail stock	Motorised synchronous rotary drive
19	Automation and NC program system	CAM Turbosoft
20	Control System	Seimens 840 D SL

(E, TBM - PEB)

ANNEXURE 2

THE INFORMATION ON THIS DOCUMENT IS THE PROPERTY OF BUNGE HEAVY ELECTRICALS LIMITED.
IT MUST NOT BE USED SEPARATELY OR IN ANY MANNER UNRELATED TO THE SERVICE OF THE COMPANY.

900995-40801-0 FIRST ANGLE PROJECTION (ALL DIMENSIONS ARE IN MM) FORM DG 46 (B)

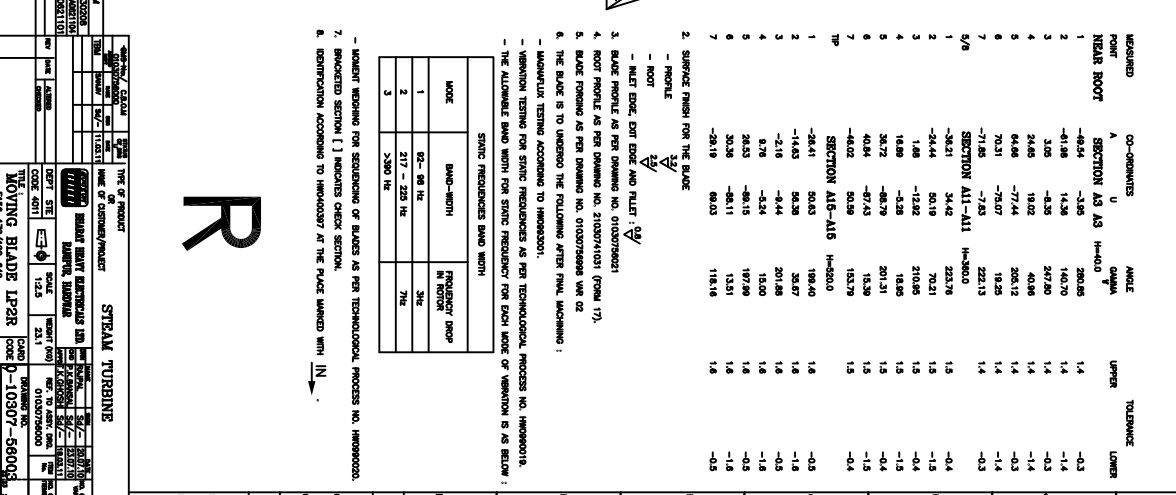
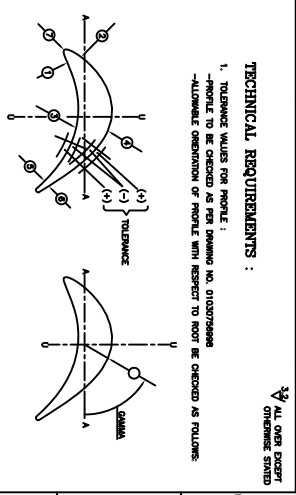
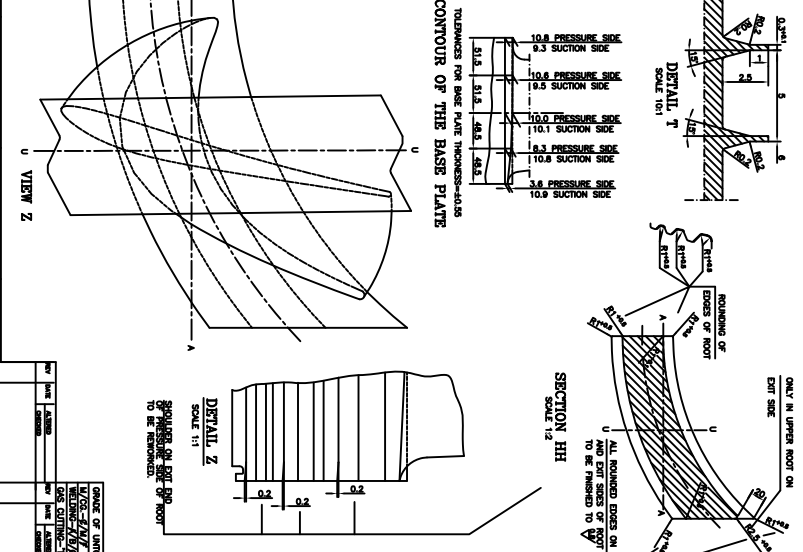
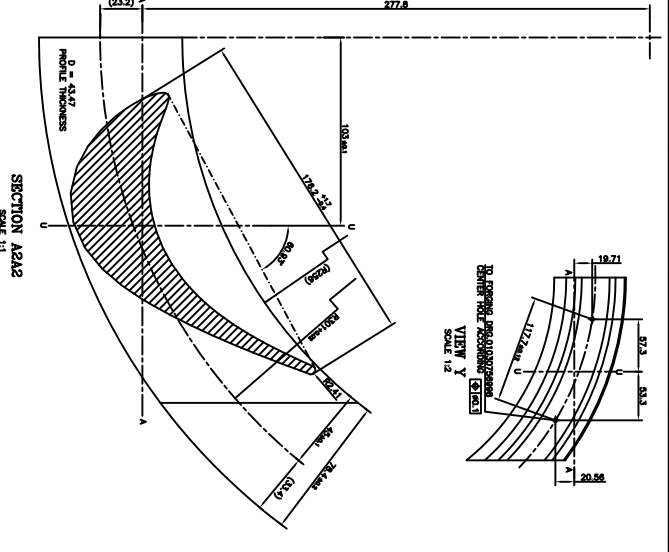
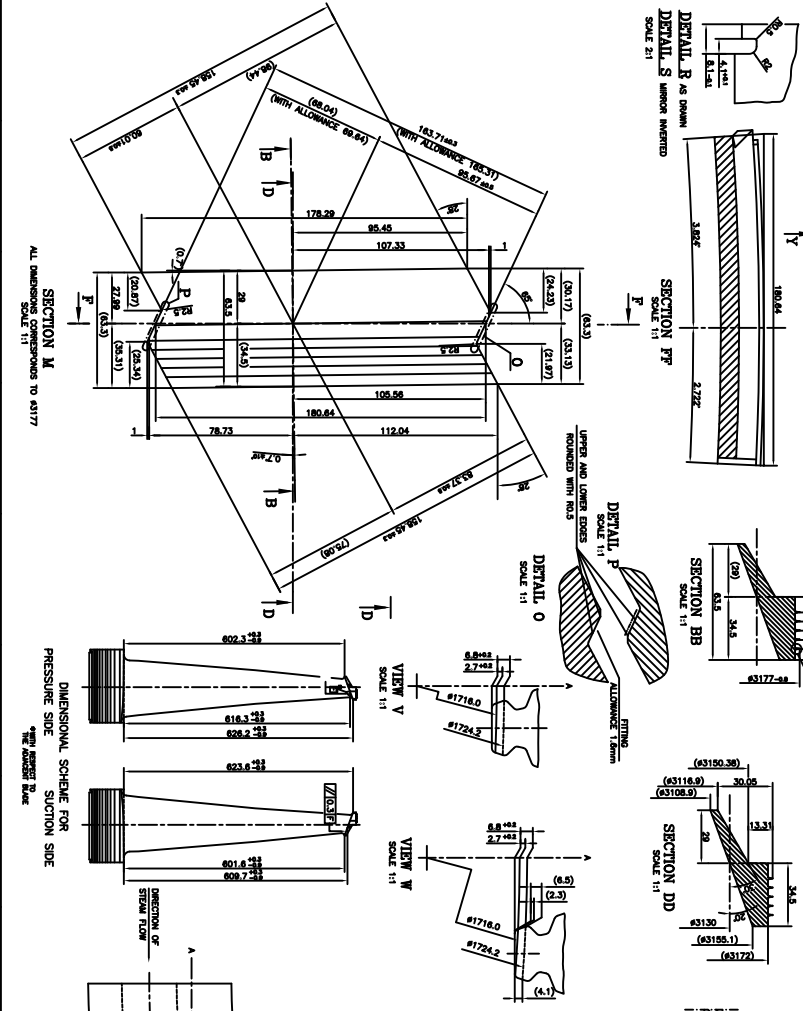
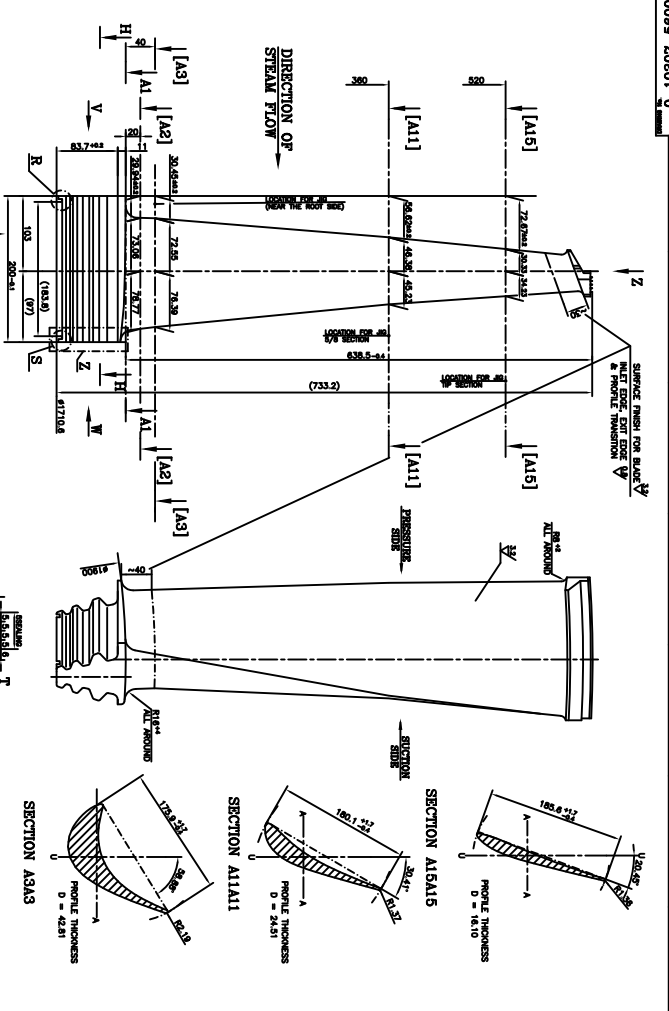

MEASURED POINT	CO-ORDINATES	ANGLE	TOLERANCE
NEAR ROOT	SECTION A3 AS	H=40.0	
1	-8.54	-3.95	20.85
2	-8.88	14.38	14.70
3	3.05	-8.35	24.70
4	24.65	19.02	40.96
5	64.66	-7.74	205.12
6	70.31	-75.07	19.25
7	-71.85	-7.83	222.13
5/8	SECTION A11-A11	H=80.0	
1	-8.21	34.42	233.79
2	-9.44	50.19	70.21
3	14.88	-13.92	210.95
4	14.88	-5.28	18.85
5	38.72	-88.79	201.31
6	40.54	-67.43	18.29
7	-60.02	50.29	153.79
7P	SECTION A16-A16	H=520.0	
1	-28.41	50.83	199.40
2	-14.83	96.38	35.87
3	-2.18	-8.44	201.86
4	8.78	-5.54	18.00
5	28.53	-88.15	197.99
6	30.36	-88.11	13.51
7	-28.19	60.03	118.16

1. TOLERANCE VALUES FOR PROFILE :
- PROFILE TO BE CHECKED AS PER DRAWING NO. 010307/0908
- ALLOWABLE ORIENTATION OF PROFILE WITH RESPECT TO ROOT BE CHECKED AS FOLLOWS
2. SURFACE FINISH FOR THE BLADE :
- ROOT : $R_{a} 1.6$
- PROFILE : $R_{a} 3.2$
- ALLET EDGE, DIRT EDGE AND FILLET : $R_{a} 6.3$
3. BLADE PROFILE AS PER DRAWING NO. 010307/0901
4. ROOT PROFILE AS PER DRAWING NO. 210307/0101 (FROM 17).
5. BLADE TOLERANCES AS PER DRAWING NO. 010307/0908 AND 02.
6. THE BLADE IS TO UNDERGO THE FOLLOWING AFTER FINAL MACHINING :
- MACHINING TOLERANCES ACCORDING TO H9/D9S10.
- MACHINING TOLERANCES FOR STATIC FREQUENCIES AS PER TECHNOLOGICAL PROCESS NO. 010307/0901A.
- THE ALLOWABLE BAND WIDTH FOR STATIC FREQUENCY FOR EACH MODE OF VIBRATION IS AS BELOW :

MODE	BAND-WIDTH	FREQUENCY DROP IN DB
1	82 - 88 Hz	3
2	217 - 225 Hz	3
3	5380 Hz	3

7. MOUNTING REQUIREMENTS FOR SECURING OF BLADES AS PER TECHNOLOGICAL PROCESS NO. 010307/0901A.
8. DIMENSIONAL SCHEME FOR CHECKING SECTION.
9. IDENTIFICATION ACCORDING TO HIGHLIGHT AT THE PLACE MARKED WITH 'N'.

R

REV	DATE	BY	CHKD	DESCRIPTION
01	17/03/2011
02	17/03/2011
03	17/03/2011
04	17/03/2011
05	17/03/2011
06	17/03/2011
07	17/03/2011
08	17/03/2011
09	17/03/2011
10	17/03/2011
11	17/03/2011
12	17/03/2011
13	17/03/2011
14	17/03/2011
15	17/03/2011
16	17/03/2011
17	17/03/2011
18	17/03/2011
19	17/03/2011
20	17/03/2011
21	17/03/2011
22	17/03/2011
23	17/03/2011
24	17/03/2011
25	17/03/2011
26	17/03/2011
27	17/03/2011
28	17/03/2011
29	17/03/2011
30	17/03/2011
31	17/03/2011
32	17/03/2011
33	17/03/2011
34	17/03/2011
35	17/03/2011
36	17/03/2011
37	17/03/2011
38	17/03/2011
39	17/03/2011
40	17/03/2011
41	17/03/2011
42	17/03/2011
43	17/03/2011
44	17/03/2011
45	17/03/2011
46	17/03/2011
47	17/03/2011
48	17/03/2011
49	17/03/2011
50	17/03/2011

REV	DATE	BY	CHKD	DESCRIPTION
01	17/03/2011
02	17/03/2011
03	17/03/2011
04	17/03/2011
05	17/03/2011
06	17/03/2011
07	17/03/2011
08	17/03/2011
09	17/03/2011
10	17/03/2011
11	17/03/2011
12	17/03/2011
13	17/03/2011
14	17/03/2011
15	17/03/2011
16	17/03/2011
17	17/03/2011
18	17/03/2011
19	17/03/2011
20	17/03/2011
21	17/03/2011
22	17/03/2011
23	17/03/2011
24	17/03/2011
25	17/03/2011
26	17/03/2011
27	17/03/2011
28	17/03/2011
29	17/03/2011
30	17/03/2011
31	17/03/2011
32	17/03/2011
33	17/03/2011
34	17/03/2011
35	17/03/2011
36	17/03/2011
37	17/03/2011
38	17/03/2011
39	17/03/2011
40	17/03/2011
41	17/03/2011
42	17/03/2011
43	17/03/2011
44	17/03/2011
45	17/03/2011
46	17/03/2011
47	17/03/2011
48	17/03/2011
49	17/03/2011
50	17/03/2011

REV	DATE	BY	CHKD	DESCRIPTION
01	17/03/2011
02	17/03/2011
03	17/03/2011
04	17/03/2011
05	17/03/2011
06	17/03/2011
07	17/03/2011
08	17/03/2011
09	17/03/2011
10	17/03/2011
11	17/03/2011
12	17/03/2011
13	17/03/2011
14	17/03/2011
15	17/03/2011
16	17/03/2011
17	17/03/2011
18	17/03/2011
19	17/03/2011
20	17/03/2011
21	17/03/2011
22	17/03/2011
23	17/03/2011
24	17/03/2011
25	17/03/2011
26	17/03/2011
27	17/03/2011	

SECTION A1-A1

Table with 12 columns for dimensions and 1 row for suction, 1 row for side, and 1 row for pressure. Includes parameters like Z=, P=, BETAS, BETABI, AI, UI, GAMMA, and GMMW.

SECTION A2-A2

Table with 12 columns for dimensions and 1 row for suction, 1 row for side, and 1 row for pressure. Includes parameters like Z=, P=, BETAS, BETABI, AI, UI, GAMMA, and GMMW.

SECTION A3-A3

Table with 12 columns for dimensions and 1 row for suction, 1 row for side, and 1 row for pressure. Includes parameters like Z=, P=, BETAS, BETABI, AI, UI, GAMMA, and GMMW.

SECTION A4-A4

Table with 12 columns for dimensions and 1 row for suction, 1 row for side, and 1 row for pressure. Includes parameters like Z=, P=, BETAS, BETABI, AI, UI, GAMMA, and GMMW.

SECTION A5-A5

Table with 12 columns for dimensions and 1 row for suction, 1 row for side, and 1 row for pressure. Includes parameters like Z=, P=, BETAS, BETABI, AI, UI, GAMMA, and GMMW.

SECTION A6-A6

Table with 12 columns for dimensions and 1 row for suction, 1 row for side, and 1 row for pressure. Includes parameters like Z=, P=, BETAS, BETABI, AI, UI, GAMMA, and GMMW.

SECTION A7-A7

Table with 12 columns for dimensions and 1 row for suction, 1 row for side, and 1 row for pressure. Includes parameters like Z=, P=, BETAS, BETABI, AI, UI, GAMMA, and GMMW.

SECTION A8-A8

Table with 12 columns for dimensions and 1 row for suction, 1 row for side, and 1 row for pressure. Includes parameters like Z=, P=, BETAS, BETABI, AI, UI, GAMMA, and GMMW.

SECTION A9-A9

Table with 12 columns for dimensions and 1 row for suction, 1 row for side, and 1 row for pressure. Includes parameters like Z=, P=, BETAS, BETABI, AI, UI, GAMMA, and GMMW.

SECTION A10-A10

Table with 12 columns for dimensions and 1 row for suction, 1 row for side, and 1 row for pressure. Includes parameters like Z=, P=, BETAS, BETABI, AI, UI, GAMMA, and GMMW.

SECTION A11-A11

Table with 12 columns for dimensions and 1 row for suction, 1 row for side, and 1 row for pressure. Includes parameters like Z=, P=, BETAS, BETABI, AI, UI, GAMMA, and GMMW.

SECTION A12-A12

Table with 12 columns for dimensions and 1 row for suction, 1 row for side, and 1 row for pressure. Includes parameters like Z=, P=, BETAS, BETABI, AI, UI, GAMMA, and GMMW.

SECTION A13-A13

Table with 12 columns for dimensions and 1 row for suction, 1 row for side, and 1 row for pressure. Includes parameters like Z=, P=, BETAS, BETABI, AI, UI, GAMMA, and GMMW.

SECTION A14-A14

Table with 12 columns for dimensions and 1 row for suction, 1 row for side, and 1 row for pressure. Includes parameters like Z=, P=, BETAS, BETABI, AI, UI, GAMMA, and GMMW.

SECTION A15-A15

Table with 12 columns for dimensions and 1 row for suction, 1 row for side, and 1 row for pressure. Includes parameters like Z=, P=, BETAS, BETABI, AI, UI, GAMMA, and GMMW.

SECTION A16-A16

Table with 12 columns for dimensions and 1 row for suction, 1 row for side, and 1 row for pressure. Includes parameters like Z=, P=, BETAS, BETABI, AI, UI, GAMMA, and GMMW.

SECTION A17-A17

Table with 12 columns for dimensions and 1 row for suction, 1 row for side, and 1 row for pressure. Includes parameters like Z=, P=, BETAS, BETABI, AI, UI, GAMMA, and GMMW.

SECTION A18-A18

Table with 12 columns for dimensions and 1 row for suction, 1 row for side, and 1 row for pressure. Includes parameters like Z=, P=, BETAS, BETABI, AI, UI, GAMMA, and GMMW.

SECTION A19-A19

Table with 12 columns for dimensions and 1 row for suction, 1 row for side, and 1 row for pressure. Includes parameters like Z=, P=, BETAS, BETABI, AI, UI, GAMMA, and GMMW.

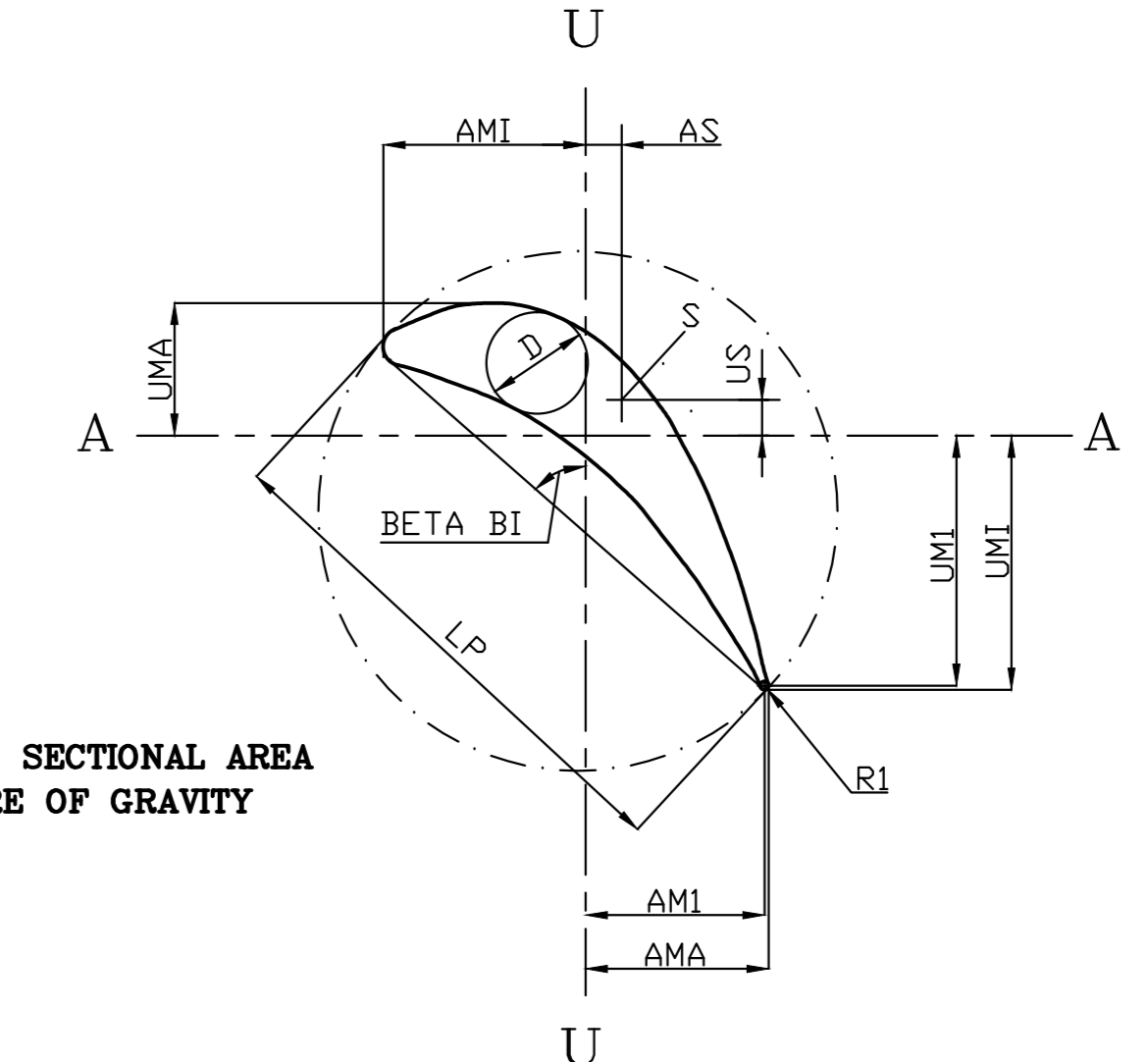

F: CROSS SECTIONAL AREA S: CENTRE OF GRAVITY

SCHEME OF PROFILE DIMENSION

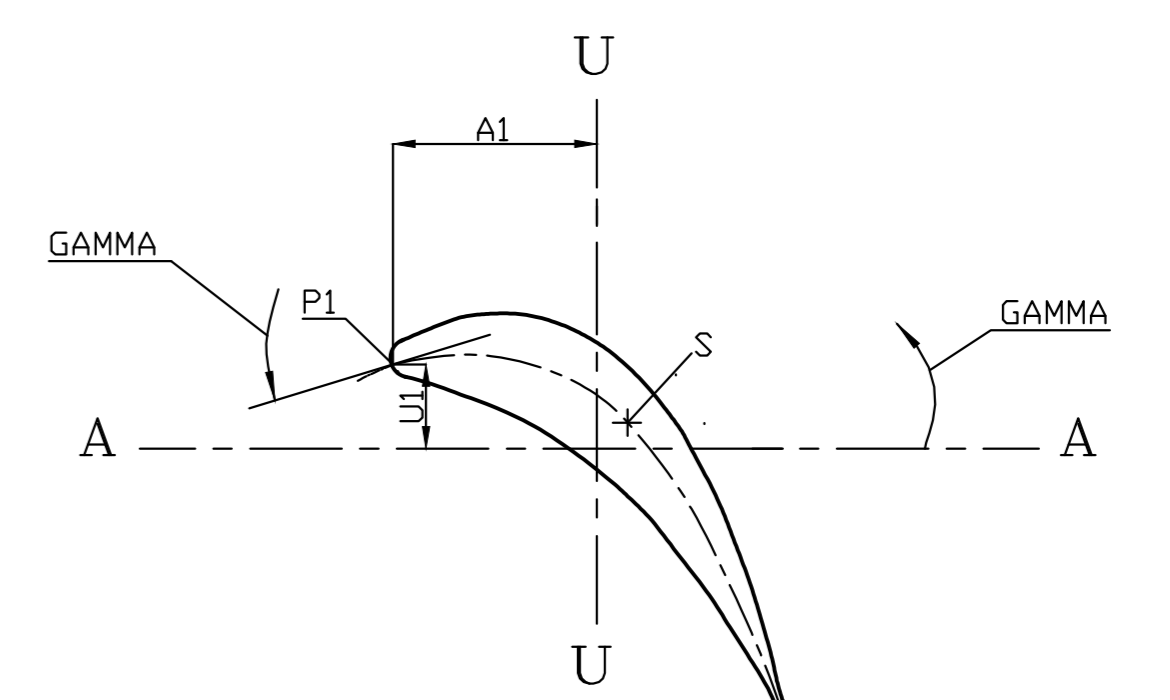

DIMENSIONS OF INLET EDGE

VERTICAL SCALE: 1:1000 HORIZONTAL SCALE: 1:1000

SECTION A1-A1 SECTION A2-A2 SECTION A3-A3 SECTION A4-A4 SECTION A5-A5 SECTION A6-A6 SECTION A7-A7 SECTION A8-A8 SECTION A9-A9 SECTION A10-A10 SECTION A11-A11 SECTION A12-A12 SECTION A13-A13 SECTION A14-A14 SECTION A15-A15 SECTION A16-A16 SECTION A17-A17 SECTION A18-A18 SECTION A19-A19

Main data table containing numerical values for various dimensions and parameters across 19 sections.

STEAM TURBINE drawing header with fields for drawing no., date, name, and scale. Includes logos for BHARAT HEAVY ELECTRICALS LTD and KAILASH.

16 15 14 13 12 11 10 9 8 7 6 5 4 3 2 1

COPYRIGHT AND CONFIDENTIAL

THE INFORMATION ON THIS DOCUMENT IS THE PROPERTY OF BHARAT HEAVY ELECTRICALS LIMITED. IT MUST NOT BE USED DIRECTLY OR INDIRECTLY IN ANY WAY DETERIMENTAL TO THE INTEREST OF THE COMPANY.

1E01F-10301-2
DRAWING No.

FIRST ANGLE PROJECTION

(ALL DIMENSIONS ARE IN mm)

FORM D6 44(8)

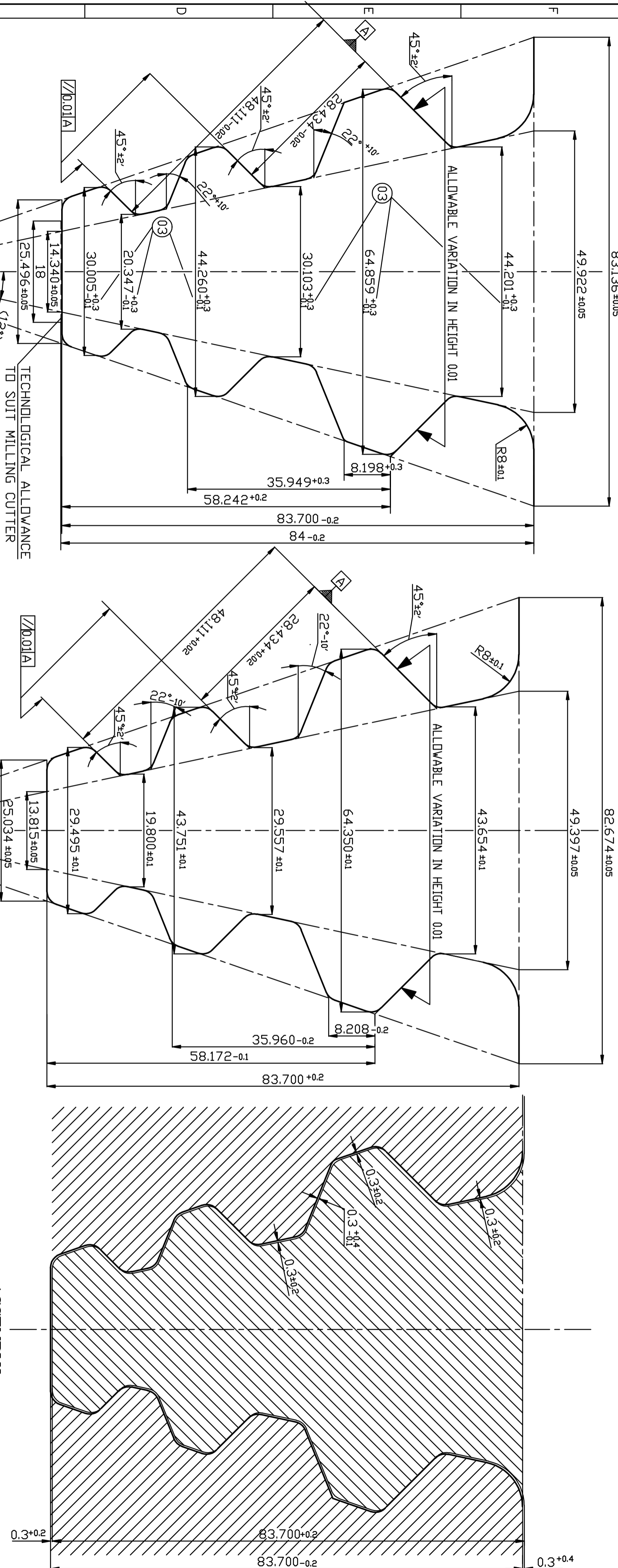

ASSEMBLY

NETWORK COORDINATES

REFERENCE DIMENSIONS FOR DESIGN

POINT	ROTOR GROOVE X	ROTOR GROOVE Y	BLADE ROOT X	BLADE ROOT Y
1	7.170	0	6.908	0
2	12.748	0	12.517	0
3	15.375	7.629	15.120	7.560
4	9.946	13.058	9.673	13.008
5	11.108	18.529	10.827	18.440
6	20.424	22.292	20.165	22.213
7	22.503	28.330	22.248	28.261
8	14.824	36.008	14.551	35.959
9	16.664	44.664	16.382	44.575
10	29.979	50.043	29.721	49.964
11	32.802	58.242	32.547	58.172
12	21.873	69.171	21.600	69.120
13	24.961	83.700	24.699	83.700
14	41.568	83.700	41.337	83.700

BLADE ROOT

SUPERSEDES OLD DRAWING UNDER THE SAME NUMBER

FORM 17

TECHNICAL REQUIREMENTS:

1. ALL UNDIMENSIONED RADII ARE TO BE R2.5±0.1
2. TOLERANCE FOR NETWORK COORDINATES ±0.01

STEAM TURBINE



BHARAT HEAVY ELECTRICALS LTD.
RANPUR, HARDWAR

NAME	SIGN	DATE	NO. OF VAR
HANS LAL	Sd/-	23.03.99	
P.K.BANSAL	Sd/-	25.03.99	
K.G.HUSH	Sd/-	28.06.99	

DEPT	STE	SCALE	WEIGHT (KG)	REF. TO ASSY. DRG.	ITEM No.	NO. OF ITEMS
4011		2:1		01030741000	73	74
TITLE: ROTOR AND GROOVE PROFILE FOR MOVING BLADE				DRAWING NO. 2-10307-41031	22	23
				SHEET No. 1	No. OF SHEETS 1	75

7353-34120
Ref. Drawing No.

Sign & Date

Inventory No

SIZE A2

ANNEXURE- 3

COMPLIANCE SHEET FOR TECHNICAL/COMMERCIAL TERMS AND CONDITIONS FOR TWO PART TENDER

PLEASE FILL THIS ANNEXURE & ATTACH WITH YOUR TECHNO-COMMERCIAL BID.

Offer must be sent in two separate sealed envelopes containing techno-commercial offer in one envelope marked “TECHNO-COMMERCIAL BID” and prices in second envelope marked “PRICE-BID”. Both the envelopes must be contained in the main envelope. Tender name and due date to be marked on all the envelopes.

You are requested to kindly confirm /clarify the following:-

S. No.	Description	Your Confirmation
1.	Vendor to confirm that they meet each & every clause of our Specifications/Drawings.	
2.	If “No” to serial number 1, vendor to specify each deviated clause & submit in a separate sheet.	
3.	Vendor to list out on a separate sheet any activity which is outsourced. Please furnish details of out sourced vendor.	
4.	Validity: confirm that validity of the offer shall be 90 days from the date of tender opening	
5.	Confirm that un-priced part of price bid is enclosed with technical commercial offer	
6.	Confirm that prices have been quoted on FOB / FCA only (For Foreign vendors)	
7.	Confirm that Loading Port has been mentioned.	
8.	Confirm that prices have been quoted on FOR as well Ex-works basis. (For Indigenous vendor)	
9.	Confirm that prices shall be firm and fixed throughout delivery period.	
10.	Payment term:- “80% of the payment shall be done against dispatch and 20% payment after successful commissioning ” and bank charges shall be either side	
11.	LD Penalty shall be applicable at the rate of ½ % (half percent) per week or part thereof subject to a maximum of 10% of the value of unexecuted portion of the order. Incase of any variation in LD penalty, your prices shall be loaded to the extend LD penalty not accepted by you.	
12.	Confirm that all test certificates / Guarantee certificates to be submitted as per BHEL specification. in TRIPLICATE along with dispatch documents	
13.	Right of acceptance – BHEL reserves the right to reject any or all quotations without assigning any reasons thereof. BHEL also reserves the right to increase or decrease the tendered quantities. Vendors should be prepared to accept order for reduced quantities without any extra charges. Vendor should also be prepared for giving discount in case of increase in quantity.	
14.	Confirm specifically that material shall be supplied as per tender documents.	
15.	No grace period in delivery is acceptable. Please quote delivery accordingly.	
16.	Ink signed order acceptance shall be furnished within 15 days of order placement.	
17.	Confirm if there is Indian agency commission included in your price.	
18.	Inspection by third party (Lloyds/BV/TUV) inspection agency as per approved quality plan. Please quote material cost and third party (Lloyds/BV/TUV) inspection charges separately & third party inspection shall be in vendor scope(For Foreign vendors)	
19.	Inspection by BHEL nominated agency as per approved quality plan. Prices shall be loaded by 0.18% on account of third party inspection charges. Third party inspection shall be in BHEL scope (For indigenous vendors)	
20.	Please confirm your acceptance for Reverse Auctioning of these items.	



ANNEXURE 4

**GUIDELINES TO FOREIGN SUPPLIERS
FOR FILLING UP SUPPLIER
REGISTRATION FORM**

Document No.	AA:MM:SR:01
Revision No.	01
Page No.	I of II

1. Prospective Suppliers may also visit our web site www.bhel.com (link Supplier Registration -> New Supplier Required) to know more about the requirement of new suppliers for various items in our units.
2. Registration Form no. SRF(F)01 may be obtained from BHEL website www.bhel.com.
3. Application for registration, with a covering letter detailing where your products can find application (if possible) in BHEL unit(s), should be sent to:

Supplier Development Cell

Unit Name:

Bharat Heavy Electricals Ltd.

City:

India

4. In case registration is being sought in multiple units of BHEL, please send the separate application to each unit.
5. Any clarification with respect to procedure for registration may be obtained from the Supplier Development Cell of respective BHEL unit.
6. All columns are to be filled up properly in the space provided for. Wherever it is not applicable, mention it as "Not Applicable". The form is to be signed by the authorized signatory and submitted in original.
7. Please attach separate sheet if the space provided is insufficient. For any other information also, separate sheet may be attached.
8. Any information / clarification required by BHEL during processing of registration must be given expeditiously.
9. Please ensure that all required enclosures are attached with the filled up Supplier Registration Form and all enclosures are numbered & list of enclosures is given as required.
10. As multiple copies of the application forms are required for processing at our end, please do not spiral bound the application forms or its enclosures and instead send them in two hole clip flat file.
11. Please fill up the check- list given on next page and send along with the Supplier Registration Forms to BHEL.
12. Please note that if you are registered and participate in Tender process and qualify to get order from BHEL, your performance based on Quality of your product, delivery performance and service rendered will be evaluated inline with Chapter VI.
13. If you are attaching a document in a language other than English, a self attested English translated document may please be also attached.

	ANNEXURE 4	Document No.	AA:MM:SR:01
	CHECK-LIST FOR FOREIGN SUPPLIERS REGISTRATION FORM	Revision No.	01
		Page No.	II of II

S.N.	Check-Point	Yes/No
1.0	Information against all points in the Supplier Registration Form has been given.	
2.0	Authorization letter has been enclosed (in case of Indian representative)	
3.0	Banker's certificate has been enclosed	
4.0	Are you an ISO: 9001 accredited supplier?	
4.1	If yes, have you enclosed copy of ISO 9001 accreditation certificate & "Table of Contents" of your Quality Manual?	
4.2	If no, have you enclosed written down procedure / manual of Quality Management System?	
5.0	Have you enclosed experience list/ performance certificate (as per sl. 3.0 of the form SRF(F) 01)	
6.0	List of enclosures has been furnished (as per Sl 5.0 of the form SRF(F) 01)	
7.0	All the parts of the form & enclosures have been signed by Authorised Signatory.	
8.0	D&B Report/ Creditreform report etc. has been attached.	

Date :

Signature & seal

(Authorised Signatory)

Note : This check list is to be attached with the filled up Supplier Registration Form.

BHARAT HEAVY ELECTRICALS LIMITED , INDIA

ANNEXURE 4

FORM NO. SRF(F)01 : (FOREIGN SUPPLIER)

Page 2 of 2

- 1.8 YEAR OF COMMENCEMENT OF BUSINESS :
- 1.9 PRODUCTION CAPACITY PER ANNUM (details of major manufacturing/ testing facilities to be given) :
- 1.10 PARTICULARS OF PRODUCTS INCLUDING SPECIFICATION AND RANGE OFFERED FOR REGISTRATION : (ATTACH BROCHURES AND CATALOGUES)
- 1.11 NAME (S) OF BANKERS :
- 1.12 BANKER'S CERTIFICATE AS TO CREDITWORTHINESS OF THE CLIENT (Enclose Certificate) :
- 1.13 PORT OF LOADING :
- 1.14 NEAREST AIRPORT :
- 1.15 Report from D&B/ Creditreform etc. (As per Cl. 7.1 of Chapter V) (**MANDATORY**):

2.0 FINANCIAL INFORMATION : (FOR LAST 3 YEARS)

PARAMETER	YEAR -1	YEAR -2	YEAR -3
ANNUAL TURN OVER			
PROFIT AFTER TAX			

(COPY OF AUDITED ANNUAL ACCOUNTS FOR LAST 3 YEARS TO BE ENCLOSED)

3.0 QUALITY MANAGEMENT SYSTEM :

- 3.1 IS THE COMPANY ISO:9001 CERTIFIED : YES / NO
- 3.1.1 IF YES, ENCLOSE COPY OF CERTIFICATE & TABLE OF CONTENTS OF QUALITY MANUAL.
- 3.1.2 IF NO, ENCLOSE QUALITY MANAGEMENT SYSTEM OR WRITTEN DOWN PROCEDURE

4.0 EXPERIENCE LIST/ PERFORMANCE CERTIFICATE FOR OFFERED / SIMILAR ITEMS :

(ATTACH LIST OF PRESENT CUSTOMERS WITH NAME & ADDRESS FOR OFFERED / SIMILAR TYPE & SIZE OF ITEM / EQUIPMENT FOR WHICH REGISTRATION HAS BEEN SOUGHT AND WITH WHOM YOU HAVE CONTINUOUS BUSINESS SINCE LAST THREE YEARS)

5.0 ANY OTHER INFORMATION :

6.0 LIST OF ENCLOSURES :

(BROCHURES, CATALOGUES, TECHNICAL LITERATURE ETC.)

Signature & Seal

AUTHORISED SIGNATORY

E – Mail

NAME :

TELEPHONE : (Landline):

DESIGNATION :

Mobile :

DATE :

BHEL CERTIFIED ASSESSOR

	ANNEXURE - 5	Document No.	AA:MM:SR:01
	GUIDELINES TO INDIAN SUPPLIERS FOR FILLING-UP SUPPLIER REGISTRATION FORM	Revision No.	01
		Page No.	I of II

- Prospective Suppliers may also visit our web site www.bhel.com (link Supplier Registration -> New Supplier Required) to know more about the requirement of new suppliers for various items in our units.
- Registration Form may be obtained from BHEL website www.bhel.com.
- Application for registration, with a covering letter detailing where your products can find application (if possible) in BHEL unit(s), should be sent to:

Supplier Development Cell
Unit Name:
 Bharat Heavy Electricals Ltd.
City:
 India

- In case registration is being sought in multiple units of BHEL, please send the separate application to each unit.
- Any clarification with respect to procedure for registration may be obtained from the Supplier Development Cell of respective BHEL unit.
- The Supplier Registration Form has four parts:

Part A	Organisational Information	Form no. SRF(I)01 – page 1 to 10
Part B	Quality System	Form no. SRF(I)01 - page 11 to 12
Part C	Technical Competence	Form no. SRF(I)01 page 13 (if sent by BHEL)
Part D	Score Sheet (to be filled by BHEL)	Form no. SRF(I)01 page 14 to 17

The set of formats to be filled by different category of suppliers is as follows:

Sl.No	Supplier Category	Formats
1.	Indian Suppliers (manufacturers)	- Organisational Information - Quality System - Technical Competence
2.	Indian Stockist/ Trader/ Distributor/ Dealer/ Authorised Agent/ Channel partner/ Indian Sales office or Subsidiary of registered foreign principal	- Organisational Information SRF(I)01- Part A (page 1 to 10 except Sl. No. 5.1, 5.2, 6.6, 6.7, 7 & 8)

- All columns are to be filled up properly in the space provided for. Wherever it is not applicable, please mention “Not Applicable”. The form is to be signed by the authorised signatory.
- A separate sheet may be attached if the space provided is insufficient or additional information is to be given. Please put proper identification tag on the separately attached sheet.
- Please ensure that all required enclosures are attached with the filled up Supplier Registration Form and all enclosures are numbered & list of enclosures is given as required.
- As multiple copies of the application forms are required for processing at our end, please do not spiral bound the application forms or its enclosures and instead send them in two hole clip flat file.
- Incomplete forms will be rejected.
- Any information / clarification required by BHEL during evaluation must be given expeditiously.
- Please note that if you are registered and participate in Tender process and qualify to get order from BHEL, your performance based on Quality of your product, delivery performance and service rendered will be evaluated inline with Chapter VI.
- Please fill up the check- list given on next page and send along with the Supplier Registration Forms to BHEL.
- If you are attaching a document in a language other than Hindi/ English, a self attested Hindi/ English translated document may please be also attached.

	ANNEXURE - 5	Document No.	AA:MM:SR:01
	Check List for Indian Supplier Registration Form	Revision No.	01
		Page No.	II of II

Sl.No.	Check-Point	Yes/No
1.	Information against all points under "Organizational Information" (Part-A) has been given.	
2.	All enclosures and supporting documents have been enclosed.	
3.	Summary list of enclosures has been furnished as per S.N.10 of Organisational Information form no. SRF (I) 01 & S.N 12 of Quality system form no. SRF (I) 01.	
4.	Are you an ISO 9001 accredited supplier?	
5.	If yes, have you enclosed "Table of Contents" of your Quality Manual and copy of ISO 9001 accreditation certificate?	
6.	Have you filled up Quality System format given in Part B?	
7.	Technical requirements, specifications, drawings, standards have been received from BHEL before filling up Technical Competence, Part C.	
8.	All the parts of the form & enclosures have been signed by Authorized Signatory.	
9.	Have you attached EFT details? (In original, Certified by the bank)	
10.	If you are seeking registration for a MSME company (as per MSME Act of Government of India), have you attached requisite certificate as per Act?	

Date :

Signature & seal

(Authorized Signatory)

Note: This check list is to be attached with the filled up Supplier Registration Form.

**BHARAT HEAVY ELECTRICALS LIMITED
SUPPLIER REGISTRATION FORM**

FORM NO. SRF(I) 01 (INDIAN SUPPLIER)

ANNEXURE - 5

Page 1 of 17

INFORMATION WITH * MARKS IS SCOREABLE.

PART- A : ORGANISATIONAL SOUNDNESS

ALL COLUMNS SHOULD BE PROPERLY FILLED IN THE SPACE PROVIDED FOR, WHEREVER IT IS NOT APPLICABLE, PLEASE WRITE "NOT APPLICABLE". INCOMPLETE OR INCORRECT FORMS MAY NOT BE CONSIDERED. PLEASE ATTACH SEPARATE SHEET, IF SPACE AVAILABLE IS INADEQUATE.

ALL THE PAGES OF THE FORM ARE TO BE SIGNED ALONGWITH SEAL BY THE AUTHORISED SIGNATORY

ORGANISATIONAL INFORMATION			
NAME AND CORRESPONDENCE ADDRESS OF THE SUPPLIER SEEKING REGISTRATION :-			
1.0 PRODUCTS / SYSTEMS / SERVICES FOR WHICH REGISTRATION IS APPLIED FOR :			
SL. NO.	DESCRIPTION	SIZE & RANGE	MFG. STD/ IS / DIN /BS ETC.
SUPPLIER'S AUTHORISED SIGNATORY		BHEL CERTIFIED ASSESSOR	

**BHARAT HEAVY ELECTRICALS LIMITED
SUPPLIER REGISTRATION FORM**

FORM NO. SRF(I) 01 (INDIAN SUPPLIER)

ANNEXURE - 5

Page 2 of 17

ORGANISATIONAL INFORMATION

2.0 GENERAL INFORMATION :

2.1 NAMES OF THE WORKS/DIVISION (Products manufactured at each works to be mentioned :

ADDRESS : E - Mail :

TELEPHONE : Landline

Mobile

FAX :

2.2 NAME OF CHIEF EXECUTIVE /
PROPRIETOR / PARTNER & ADDRESS :

2.3 DETAILS OF AUTHORISED SIGNATORY FOR SEEKING CLARIFICATION :

NAME :

DESIGNATION : E - Mail

:

TELEPHONE : Landline

Mobile

FAX :

SUPPLIER'S AUTHORISED SIGNATORY

BHEL CERTIFIED ASSESSOR

**BHARAT HEAVY ELECTRICALS LIMITED
SUPPLIER REGISTRATION FORM**

FORM NO. SRF(I) 01 (INDIAN SUPPLIER)

ANNEXURE - 5

Page 3 of 17

ORGANISATIONAL INFORMATION

3.0 OWNERSHIP INFORMATION : DOCUMENTS TO BE FURNISHED

3.1 GOVT. OF INDIA UNDERTAKING:

OR

STATE GOVT. UNDERTAKING :

OR

LIMITED COMPANY, :

MEMORANDUM AND
ARTICLES OF ASSOCIATION

OR

PRIVATE COMPANY :

MEMORANDUM AND
ARTICLES OF ASSOCIATION

OR

CO-OPERATIVE SOCIETY, :

SOCIETY RULES AND
BYE LAWS

OR

PARTNERSHIP FIRM, :

PARTNERSHIP DEED

OR

PROPRIETORSHIP, :

PROFESSION TAX REGN.
AND MUNICIPAL REGN.

ANY OTHER (SPECIFY) :

3.2 NATURE OF BUSINESS :
(MANUFACTURING UNIT/
ENGG CONSULTANT/ EPC CONTRACTOR)

(AGENTS/ DISTRIBUTORS/STOCKISTS/DEALERS/
TRADERS/ INDIAN SUBSIDIARY/ CHANNEL PARTNER – attach authorization
certificate of principal)

3.3 YEAR OF ESTABLISHMENT :

* 3.4 YEAR OF COMMENCEMENT OF BUSINESS :

SUPPLIER'S AUTHORISED SIGNATORY

BHEL CERTIFIED ASSESSOR

**BHARAT HEAVY ELECTRICALS LIMITED
SUPPLIER REGISTRATION FORM**

FORM NO. SRF(I) 01 (INDIAN SUPPLIER)

ANNEXURE - 5

Page 4 of 17

ORGANISATIONAL INFORMATION

4.0 REGISTRATION PARTICULARS

(FURNISH DETAILS AND ENCLOSE COPY OF CERTIFICATE FOR THE FOLLOWING)

4.1 PERMANENT ACCOUNT NO :
4.2 CENTRAL SALES TAX REGN NUMBER :
4.3 STATE SALES TAX / TIN NUMBER :
4.4 EXCISE DUTY REGN NUMBER :
4.5 EXCISE CONTROL CODE NUMBER :
4.6 SERVICE TAX REGN NUMBER :
4.7 CATEGORY AS PER MSMED ACT : MICRO/ SMALL/ MEDIUM
REGN NO. :
VALID UPTO :
(Attach Certificate)

5.0 TOTAL ORGANISATIONAL STRENGTH : (ATTACH ORGANISATION CHART)

	GRADUATE	DIPLOMA	SKILLED	NON-SKILLED
ENGINEERING :				
MANUFACTURING :				
QUALITY :				
COMMERCIAL / SERVICE AFTER SALES :				
OTHERS :				
TOTAL :				
* 5.1 POWER BACKUP : (GIVE DETAILS)	YES/ NO			

* 5.2 DOES THE COMPANY SELL ITS PRODUCT DIRECTLY : YES/ NO

SUPPLIER'S AUTHORISED SIGNATORY

BHEL CERTIFIED ASSESSOR

**BHARAT HEAVY ELECTRICALS LIMITED
SUPPLIER REGISTRATION FORM**

FORM NO. SRF(I) 01 (INDIAN SUPPLIER)

ANNEXURE - 5

Page 5 of 17

ORGANISATIONAL INFORMATION

6.0 OTHER PARTICULARS :

(FURNISH DETAILS AND ENCLOSE DOCUMENTARY EVIDENCE/ COPY OF CERTIFICATE FOR THE FOLLOWING)

* 6.1 IF THE COMPANY IS ALREADY REGISTERED WITH ANY OF BHEL UNITS, GIVE :

6.1.1. BHEL UNIT'S NAME :

6.1.2. SUPPLIER REGN. CODE NO. :

6.1.3. ITEMS FOR WHICH REGISTERED & THEIR SPECIFICATION
(ENCLOSE PROOF OF SUCCESSFUL EXECUTION OF
ONE OR MORE PURCHASE ORDERS) :

* 6.2 IS THE COMPANY APPROVED BY
ASME / NTPC / NPC / EIL / DGS&D / RAILWAYS /
IBR / LLOYDS ETC FOR INTENDED
MATERIAL CATEGORY? : YES / NO
(ENCLOSE DOCUMENTARY EVIDENCE)

* 6.3 IS THE COMPANY ISO 9001 APPROVED? : YES / NO
(ENCLOSE CERTIFICATE & TOC OF QUALITY SYSTEM) :

* 6.4 IS THE COMPANY AN ISO 14000 APPROVED? : YES / NO
(ENCLOSE CERTIFICATE) :

* 6.5 IS THE COMPANY OHSAS - 18000 APPROVED?: YES / NO
(ENCLOSE CERTIFICATE)

* 6.6 TECHNICAL COLLABORATOR :
(FOREIGN OR INDIGENOUS)
(ENCLOSE DOCUMENTARY EVIDENCE)

* 6.7 R&D SET UP

6.8 DIRECTORS / PARTNERS, IF RELATED TO ANY
BHEL EMPLOYEE.
NAME :
STAFE NO. :
DESIGNATION :
Unit & DEPARTMENT :
RELATIONSHIP :

SUPPLIER'S AUTHORISED SIGNATORY

BHEL CERTIFIED ASSESSOR

**BHARAT HEAVY ELECTRICALS LIMITED
SUPPLIER REGISTRATION FORM**

FORM NO. SRF(I) 01 (INDIAN SUPPLIER)

ANNEXURE - 5

Page 6 of 17

ORGANISATIONAL INFORMATION

6.9 IF ANY EX-BHEL PERSONNEL IS EMPLOYED BY THE COMPANY, MENTION HIS / HER DETAILS OF LAST POSTING.

NAME :
STAFF NO. :
DESIGNATION :
UNIT & DEPARTMENT :
DATE OF LEAVING SERVICE :

6.10 COMPANY'S WEEKLY HOLIDAYS :

WORKS OFFICE

6.11 EXPERIENCE LIST:

(ATTACH LIST OF PRESENT CUSTOMERS WITH NAME & ADDRESS FOR OFFERED / SIMILAR TYPE & SIZE OF ITEM / EQUIPMENT FOR WHICH REGISTRATION HAS BEEN SOUGHT AND WITH WHOM YOU HAVE CONTINUOUS BUSINESS SINCE LAST THREE YEARS . ALSO ATTACH PERFORMANCE CERTIFICATES ISSUED BY ANY TWO CLIENTS FOR SUCCESSFUL EXECUTION OF THE CONTRACTS FOR LAST TWO YEARS- FOR PEM)

*6.12 DETAILS OF PENDING LEGAL ISSUES ON CONTRACTUAL ASPECTS WITH CUSTOMER , IF ANY

6.13 The following information of Bank Account of the Company, duly endorsed by the Bank (required for Electronic Fund Transfer –EFT/RTGS) is to be submitted

1. Name of the Company
2. Name of Bank
3. Name of Bank Branch
4. City/Place
5. Account Number
6. Account type
7. IFSC code of the Bank Branch
8. MICR Code of the Bank Branch
9. Details of other Bankers (for reference purpose only)

NOTE :

(i) Suppliers who have already submitted the above information are requested to submit a copy of the same.

SUPPLIER'S AUTHORISED SIGNATORY

BHEL CERTIFIED ASSESSOR

**BHARAT HEAVY ELECTRICALS LIMITED
SUPPLIER REGISTRATION FORM**

FORM NO. SRF(I) 01 (INDIAN SUPPLIER)

ANNEXURE - 5

Page 7 of 17

ORGANISATIONAL INFORMATION

7.0 MANUFACTURING FACILITIES:

***7.1 LIST OF MANUFACTURING FACILITIES/EQUIPMENTS (INCLUDING MATERIAL HANDLING FACILITY)**

SL. NO	DESCRIPTION OF MACHINE/EQUIPMENT	QUANTITY	MAKE & YEAR OF INSTALLATION	REMARKS

IN CASE OF SPACE LIMITATION, PLEASE ENCLOSE ANNEXURE / CATALOGUE WITH TAG

*** 7.2 IF IN-HOUSE MFG FACILITIES NOT AVAILABLE, INFORM SOURCE OF MFG. DETAILS ALONGWITH THEIR FACILITIES & EXPERIENCE**

SL. NO	PROCESS OUTSOURCED	NAME OF THE COMPANY	DESCRIPTION OF MACHINE / EQUIPMENT	REMARKS

IN CASE OF SPACE LIMITATION ENCLOSE ANNEXURE / CATALOGUE WITH TAG

*** 7.3 RATIO OF OUTSOURCED COST TO TOTAL PRODUCTION VALUE:**

SUPPLIER'S AUTHORISED SIGNATORY

BHEL CERTIFIED ASSESSOR

**BHARAT HEAVY ELECTRICALS LIMITED
SUPPLIER REGISTRATION FORM**

FORM NO. SRF(I) 01 (INDIAN SUPPLIER)

ANNEXURE - 5

Page 8 of 17

ORGANISATIONAL INFORMATION

8.0 INSPECTION & TESTING FACILITIES:

*** 8.1 LIST OF INSPECTION & TESTING FACILITIES / EQUIPMENT**

SL. NO	DESCRIPTION OF FACILITY/ EQUIPMENT & CAPACITY	NOS.	MAKE & YEAR OF MANUFACTURING	LAST DATE OF CALIBERATION

IN CASE OF SPACE LIMITATION ENCLOSE ANNEXURE / CATALOGUE WITH TAG

*** 8.2 IF IN-HOUSE TESTING FACILITIES NOT AVAILABLE, INDICATE SOURCE OF TESTING ALONGWITH THEIR FACILITIES & EXPERIENCE**

SL. NO	TEST	SOURCE OF TESTING	DESCRIPTION OF FACILITY/ EQUIPMENT & CAPACITY	APPROVAL OF EQUIPMENT/ PROCESS/PERSONNEL QUALIFICATION

IN CASE OF SPACE LIMITATION ENCLOSE ANNEXURE / CATALOGUE WITH TAG

Note:

In case of outsourcing of major testing such as NDT, Electrical & Mechanical Testing, no marks will be awarded. However, material composition testing by chemical method from recognized laboratory shall not attract negative marking

SUPPLIER'S AUTHORISED SIGNATORY	BHEL CERTIFIED ASSESSOR
---------------------------------	-------------------------

**BHARAT HEAVY ELECTRICALS LIMITED
SUPPLIER REGISTRATION FORM**

FORM NO. SRF(I) 01 (INDIAN SUPPLIER)

ANNEXURE - 5

Page 9 of 17

ORGANISATIONAL INFORMATION					
FINANCIAL INFORMATION FOR THE PREVIOUS FOUR YEARS					
9.0	Parameter	Year 1	Year 2	Year 3	Year 4
		(Years in ascending order, Money value in Rs. Lakhs)			
* 9.1	NET WORTH (Share Capital +Reserves)				
	Growth over previous year (%)	-----			
9.2	LONG TERM DEBT / LOAN				
* 9.3	DEBT EQUITY RATIO <u>Long term Debt (9.2)</u> <u>Net worth (9.1)</u>				
9.4	INVESTMENT IN: Land & Building				
	Plant & Machinery				
	Other Fixed Assets				
9.5*	NET CURRENT ASSETS				
	1 a) Cash on hand				
	b) Account receivable				
	c) Inventories				
	Total				
	CURRENT LIABILITY				
	2 a) Sundry creditors				
	b) Interest accrued but not due				
c) Other liabilities					
Total					
	* QUICK RATIO <u>CA - INVENT. {9.5(1)-9.5(1)c}</u> 3 <u>Current liability {9.5 (2)}</u>				
* 9.6	SALES				
	Growth over previous year (%)	-----			
* 9.7	PROFIT BEFORE TAX				
	Growth over previous year (%)	-----			
* 9.8	Whether the supplier has been referred to BIFR / NCLT / any other Govt agency (If YES , enclose details)				YES / NO
* 9.9	Whether the supplier is a potential sick company.(If YES , enclose details)				YES / NO
NOTE: 1. Copies of annual accounts (Balance Sheet) for the last four years (or from date of incorporation which ever is less) along with audit report are to be submitted. The above details shall be highlighted in the Balance Sheet. 2. Status of Tax assessments done under various laws (Income Tax, VAT/Sales Tax, Excise & Service Tax, Custom) and details of disputes pending, if any, with these authorities to be submitted.					
SUPPLIER'S AUTHORISED SIGNATORY			BHEL CERTIFIED ASSESSOR		

**BHARAT HEAVY ELECTRICALS LIMITED
SUPPLIER REGISTRATION FORM**

FORM NO. SRF(I) 01 (INDIAN SUPPLIER)

ANNEXURE - 5

Page 10 of 17

ORGANISATIONAL INFORMATION

10. LIST OF ENCLOSURES (Tags to be put on enclosures) :

- (i) MEMORANDUM AND ARTICLES OF ASSOCIATION / SOCIETY RULES AND BYE LAWS / PARTNERSHIP DEED/ PROFESSION TAX REGN & MUNICIPAL REGN. : YES / NO
- (ii) Copy of certificate of following:-
- X PERMANENT ACCOUNT NO : YES / NO
 - X CENTRAL SALES TAX REGN NUMBER : YES / NO
 - X STATE SALES TAX / TIN NUMBER : YES / NO
 - X EXCISE DUTY REGN NUMBER : YES / NO
 - X EXCISE CONTROL CODE NUMBER : YES / NO
 - X SERVICE TAX REGN NUMBER : YES / NO
 - X REGN NUMBER OF CATEGORY AS PER MSMED ACT : YES / NO
- (iii) ORGANISATION CHART : YES / NO
- (iv) If registered with any other BHEL Unit,
- X LETTER OF REGISTRATION WITH BHEL UNIT : YES / NO
 - X PROOF OF SUCCESSFUL EXECUTION OF ONE OR MORE PURCHASE ORDERS : YES / NO
- (v) Letter of approval from ASME / NTPC / NPC / EIL / DGS&D / RAILWAYS /IBR / LLOYDS ETC : YES / NO
- (vi) Accreditation certificate for
- X ISO: 9001 : YES / NO
 - X TOC of Quality System Manual : YES / NO
 - X ISO : 14000 : YES / NO
 - X OHSAS , ISO 18000 : YES / NO
- (vii) Letter regarding technical collaboration : YES / NO
- (viii) Experience List / Performance certificate : YES / NO
- (ix) Balance Sheet for the last four years along with audit Report : YES / NO
- (x) Principal's authorization in case of dealers/ agents : YES / NO
- (xi) EFT Bank's certificate : YES / NO

I /WE GIVE THE UNDERTAKING THAT BHEL DRAWINGS & SPECIFICATIONS SHALL NOT BE USED IN ANY WAY DETRIMENTAL TO THE INTEREST OF BHEL AND/ OR FOR SUPPLY OF ANY MATERIAL, PRODUCT OR SERVICES DIRECTLY OR INDIRECTLY TO ANY OTHER CUSTOMER.

Maximum Marks = 50

Negative Marks = -13

Minimum Qualifying marks = 30

SUPPLIER'S AUTHORISED SIGNATORY

BHEL CERTIFIED ASSESSOR

**BHARAT HEAVY ELECTRICALS LIMITED
SUPPLIER REGISTRATION FORM**

FORM NO. SRF(I) 01 (INDIAN SUPPLIER)

ANNEXURE - 5

Page 11 of 17

FORM NO. SRF(I) 01

Part B (QUALITY SYSTEM):

Sl. No	PARAMETERS	SYSTEM IN EFFECT (Tick if exists & provide evidences if ticked in written procedure)		RECORDS (Tick if available & submit evidences)	REMARKS
		Written Procedure	Practice		
1*	Incoming Material Control System				Furnish a copy of system and organization.
2*	In process control				Furnish at least one work instruction & record of process control parameter
3*	Manufacturing / Testing Procedure Qualification				Procedure Qualification specification may be submitted
4*	Personnel qualification for 3 above.				Record of Personnel qualification (PQR) to be submitted
5*	Calibration system				Submit list of instrument & their calibration status
6*	System of Identification & Traceability of materials, tools, jigs, fixtures & processed components, etc.				Copy of procedure to be submitted
7*	System of Storage, Preservation, Painting & packing				Copy of procedure to be submitted
8*	System of NCR disposition & corrective preventive action				Two copies of NCR & CAPA
9*	Customer complaints handling system				Submit list of customer complaints & status for the last three years
10*	Safety measures				Submit copy of safety system & Record of accidents for last three years
11	Any other quality initiative				

SUPPLIER'S AUTHORISED SIGNATORY

BHEL CERTIFIED ASSESSOR

**BHARAT HEAVY ELECTRICALS LIMITED
SUPPLIER REGISTRATION FORM**

FORM NO. SRF(I) 01 (INDIAN SUPPLIER)

ANNEXURE - 5

Page 12 of 17

FORM NO. SRF(I) 01

Part B (QUALITY SYSTEM):

12. LIST OF ENCLOSURES

- (i) Copy of system of control incoming materials and organization chart
- (ii) Copy of at least one process control work instruction
- (iii) Record of process control parameter
- (iv) Copy of at least one Procedure Qualification specification
- (v) Record of Personnel qualification (PQR)
- (vi) List of instrument & their calibration status
- (vii) Copy of procedure for Identification & Traceability of materials, tools, jigs, fixtures & processed components, etc.
- (viii) Copy of procedure for Storage/ preservation/ painting & packing
- (ix) Copies of two NCRs and their CAPA.
- (x) List of customer complaints & status for the last three years
- (xi) Copy of safety system
- (xii) Record of accidents for last three years

Maximum Marks = 25

Minimum Qualifying marks = 15

SUPPLIER'S AUTHORISED SIGNATORY

BHEL CERTIFIED ASSESSOR

**BHARAT HEAVY ELECTRICALS LIMITED
SUPPLIER REGISTRATION FORM**

FORM NO. SRF(I) 01 (INDIAN SUPPLIER)

ANNEXURE - 5

Page 13 of 17

FORM NO. SRF(D)01

Part C : TECHNICAL COMPETENCE

Technical competence shall be evaluated in two parts viz. common competence and product/material category specific competence.

(i) COMMON TECHNICAL COMPETENCE (Max Marks: 10)

TECHNICAL COMPETENCE (where design specification is given by BHEL)	MARKING RANGE	SUPPLIER RESPONSE (ALONG WITH SUPPORTING DOCUMENTS)#	MARKS BY BHEL
1. Supplier understands the product specification.	(0-3)		
2. Supplier understands the inspection requirements.	(0-2)		
3. Supplier has process capability to achieve the product specification/dimensional requirement.	(0-3)		
4. Supplier has experienced manpower to carry out the job.	(0-2)		
TOTAL MARKS OUT OF POSSIBLE (10) = ---			

OR

TECHNICAL COMPETENCE (where performance specification is given by BHEL)	MARKING RANGE	PROCEDURE		SYSTEM IN EFFECT		RECORDS	
		SUPPLIER RESPONSE (ALONG WITH SUPPORTING DOCUMENTS)#	MARKS BY BHEL	SUPPLIER RESPONSE (ALONG WITH SUPPORTING DOCUMENTS)#	MARKS BY BHEL	SUPPLIER RESPONSE (ALONG WITH SUPPORTING DOCUMENTS)#	MARKS BY BHEL
1. Design capability	(0-3)						
2. Adequacy of quality assurance plan	(0-2)						
3. Process capability for components	(0-3)						
4. Adequate of testing	(0-2)						
TOTAL MARKS OUT OF POSSIBLE (10)							
Average of Total (Total/3) = -----							

(ii) PRODUCT/ MATERIAL CATEGORY SPECIFIC TECHNICAL COMPETENCE

(Max Marks: 15)

Unit MISCC to structure the parameters to be considered for the technical competence depending on material category. The score of individual parameter selected is to be decided by MISCC. MISCC shall identify the requirement of enclosures to be furnished by supplier

Product:

Sl. No	Material category	Tech Parameter	Supplier's response	Remarks

To be filled up only on receipt of technical requirements/ specification, drawings, standards from BHEL and to be sent to BHEL for further scrutiny. Enclose documentary evidence where ever required.

LIST OF ENCLOSURES:

Maximum Marks = 25

Minimum Qualifying marks = 15

No marks is to be given by the supplier. Only supplier response along with supporting documents,

SUPPLIER'S AUTHORISED SIGNATORY	BHEL CERTIFIED ASSESSOR
---------------------------------	-------------------------

**BHARAT HEAVY ELECTRICALS LIMITED
SUPPLIER REGISTRATION FORM**

FORM NO. SRF(I) 01 (INDIAN SUPPLIER)

ANNEXURE - 5

Page 14 of 17

Part D : SCORE SHEET

1. ORGANISATIONAL SOUNDNESS (for Manufacturers):

S.N.	PARAMETER	CRITERIA	Maxm. Marks	Marks Awarded
1.	Whether all relevant information like ownership, PAN no., sales tax no., excise duty no., etc. submitted	Yes: 2 No: 0	2	
2.	3.4 YEAR OF COMMENCEMENT OF BUSINESS	More than 5 years : 2 1-5 years : 1 Less than 1 year : 0	2	
3.	5.1 POWER BACKUP	Yes : 1 No : 0	1	
4.	5.2 DOES THE COMPANY SELL ITS PRODUCT DIRECTLY	Yes : 1 No : 0	1	
5.	6.1 REGISTERED WITH ANY OF BHEL UNITS	Yes (same item) : 2 Yes (another item) : 1 No : 0	2	
6.	6.2 APPROVAL BY ASME/ NTPC/ NPC/ EIL/ DGS&D/ RAILWAYS/ IBR/ LLOYDS ETC	Yes : 2 No : 0	2	
7.	6.3 ISO 9001 ACCREDITATION	Yes : 3 No : 0	3	
8.	6.4 ISO 14000 ACCREDITATION	Yes : 1 No : 0	1	
9.	6.5 OHSAS - 18000 ACCREDITATION	Yes : 1 No : 0	1	
10.	6.6 TECHNICAL COLLABORATOR : (FOREIGN OR INDIGENOUS)	Yes : 1 No : 0	1	
11.	6.7 R & D SET UP	Yes : 1 No : 0	1	
12.	6.12 PENDING LEGAL ISSUES ON TECHNO – COMMERCIAL ASPECTS WITH CUSTOMER	Yes : -5 No : 0	0	
13.	7.1 & 7.2 MANUFACTURING FACILITIES INCLUDING OUTSOURCING	Adequate : 3 Substantial : 2 Inadequate : 0	3	
14.	7.3 RATIO OF OUTSOURCED COST TO TOTAL PRODUCTION VALUE	Less than 10% : 2 10 to 30 % : 1 More than 30% : 0	2	
15.	8.1 INSPECTION & TESTING FACILITIES	Adequate : 2 Substantial : 1 Inadequate : 0	2	
16.	8.2 OUTSOURCING OF MAJOR TESTING FACILITY (Refer Note)	Yes : 0 No : 1	1	
	TOTAL		25	

1. ORGANISATIONAL SOUNDNESS (for Indian Stockist/ Trader/ Distributor/ Dealer/ Authorised Agent/ Channel partner/ Indian Sales office or Subsidiary of registered foreign principal):

S.N.	PARAMETER	CRITERIA	Maxm. Marks	Marks Awarded
1.	Whether all relevant information like ownership, PAN no., sales tax no., etc. submitted (clause 6.0 of chapter V to be referred in this regard)	Yes: 7 No: 0	7	
2.	3.4 YEAR OF COMMENCEMENT OF BUSINESS	More than 3 years : 2 1-3 years : 1 Less than 1 year : 0	2	
3.	6.1 REGISTERED WITH ANY OF BHEL UNITS	Yes (same item) : 2 Yes (another item) : 1 No : 0	2	
4.	6.2 APPROVAL BY ASME/ NTPC/ NPC/ EIL/ DGS&D/ RAILWAYS/ IBR/ LLOYDS ETC	Yes : 2 No : 0	2	
5.	6.3 ISO 9001 ACCREDITATION	Yes : 2 No : 0	2	
6.	6.12 PENDING LEGAL ISSUES ON TECHNO – COMMERCIAL ASPECTS WITH CUSTOMER	Yes : -5 No : 0	0	

BHEL CERTIFIED ASSESSOR

**BHARAT HEAVY ELECTRICALS LIMITED
SUPPLIER REGISTRATION FORM**

FORM NO. SRF(I) 01 (INDIAN SUPPLIER)

ANNEXURE - 5

Page 15 of 17

Part D: SCORE SHEET

2. FINANCIAL INFORMATION (for Manufacturers):

S.N.	PARAMETER	CRITERIA	Maximum Marks	Marks Awarded
1.	9.1 Growth of Net Worth over previous year (%) Average of three years to be worked out	More than 20 % : 5 10 – 20 % : 4 5 – 10 % : 3 > 0 & < 5 % : 2 0 or below : 0	5	
2.	9.3 DEBT EQUITY RATIO <u>Long term Debt (9.2)</u> Net worth (9.1)	1 : 1 : 5 1.1 upto 1.5 : 1 : 4 1.6 upto 2.0 : 1 : 3 2.0 & above : 1 : 2	5	
3.	9.5 QUICK RATIO <u>CA - INVENTORIES {9.5(1)-9.5(1)c}</u> Current liability {9.5 (2)}	1 : 1 : 5 1 : 1 upto 1.5 : 4 1 : 1.5 upto 1.75 : 3 1 : 1.75 upto 2.5 : 2 1 : > 2.5 : 0	5	
4.	9.6 Growth in Sales over previous year (%) Average of three years to be worked out	More than 35% : 5 20 -35 % : 4 10 – 20 % : 3 5 – 10 % : 2 > 0 & < 5 % : 1 0 or negative : 0	5	
5.	9.7 PROFIT BEFORE TAX Growth over previous year (%)	More than 20 % : 5 10 – 20 % : 4 5 – 10 % : 3 > 0 & < 5 % : 2 0 or below : 0	5	
6.	9.8 Whether the supplier has been referred to BIFR / NCLT/ any other similar Govt agency	Yes: -5 No : 0	0	
7.	9.9 Whether the supplier is a potentially sick company	Yes: -3 No : 0	0	
TOTAL			25	

Note: If the supplier is new in business and does not have past data, then the evaluation will be done on the basis of information provided by him and will be decided by MISCC.

2. FINANCIAL INFORMATION (for Indian Stockist/ Trader/ Distributor/ Dealer/ Authorised Agent/ Channel partner/ Indian Sales office or Subsidiary of registered foreign principal):

S.N.	PARAMETER	CRITERIA	Maximum Marks	Marks Awarded
1.	9.6 Growth in Sales over previous year (%) Average of three years to be worked out	More than 35% : 5 20 -35 % : 4 5 - 20 % : 3 >0 - 5 % : 2 0 or negative : 0	5	
2.	9.7 PROFIT BEFORE TAX Growth over previous year (%)	More than 20 % : 5 5 – 20 % : 4 >0 – 5 % : 3 0 or below : 0	5	

BHEL CERTIFIED ASSESSOR

**BHARAT HEAVY ELECTRICALS LIMITED
SUPPLIER REGISTRATION FORM**

FORM NO. SRF(I) 01 (INDIAN SUPPLIER)

ANNEXURE - 5

Page 16 of 17

Part D : SCORE SHEET

3. QUALITY SYSTEM :

S.N.	PARAMETER	CRITERIA	Maxm. Marks	Marks Awarded
1.	Incoming Material control System	System availability : Yes: 1 No : 0	1	
		Availability of Organisation chart Yes: 1 No : 0	1	
2.	Process control	Work instruction available: Yes: 1 No : 0	1	
		Record of process Control : Available : 2 Partial record : 1 Not available: 0	2	
3.	Manufacturing / Testing Procedure Qualification	Procedure Qualification Specification : Adequate : 3 In adequate: 1 Not available : 0	3	
4.	Personnel qualification	Record of PQR: Adequate : 3 In adequate: 1 Not available : 0	3	
5.	Calibration system	Adequate : 3 In adequate: 1 Not available : 0	3	
6.	System of Identification & Traceability of materials, tools, jigs, fixtures & processed components, etc.	Procedure available : Adequate : 2 In adequate: 1 Not available : 0	2	
7.	System of Storage/ preservation/ painting & packing	Procedure available : Adequate : 2 In adequate: 1 Not available : 0	2	
8.	System of NCR disposition & corrective preventive action	Two copies of NCR & CAPA Available :2 Not available : 0	2	
9.	Customer complaints handling system	System available : Yes: 1 No : 0	1	
		Complaints registered & resolved : 2 Complaints registered & partially resolved : 1 Complaints not registered or not resolved : 0	2	
10.	Safety measures	System available : Yes: 1 No : 0	1	
		Record available : Yes: 1 No : 0	1	
	TOTAL		25	
BHEL CERTIFIED ASSESSOR				

**BHARAT HEAVY ELECTRICALS LIMITED
SUPPLIER REGISTRATION FORM**

FORM NO. SRF(I) 01 (INDIAN SUPPLIER)

ANNEXURE - 5

Page 17 of 17

Part D : SCORE SHEET

4. TECHNICAL COMPETENCE

Column no. 1 to 4 to be filled by MISCC before sending to supplier. Column no. 5 to be filled by BHEL certified Assessor after evaluation of supplier response.

Sl. No (1)	Parameter (2)	Scoring criteria (3)	Maximum Marks (4)	Marks obtained (5)
	TOTAL		25	

SUMMARY:

Sl. No	Criteria	Maxm Marks	Qualifying marks *	Marks obtained	Recommendation for registration
1.	Organisational Soundness	50	30		Recommended : Permanent code /Development code/ Trial code
	Financial Information				
2.	Quality System	25	15		
3.	Technical Competence	25	15		
	TOTAL	100	60		Not recommended

***Minimum Qualifying Score in Each category shall be 60%.**

REGISTRATION CRITERIA:

Sl. No	Score	Recommendation
1.	More than 90	Supplier is to be registered and given Permanent code, Normally no visit is called for.
2.	>75 <=90	Supplier may be visited if recommended by MISCC or to be registered and given permanent code.
3.	>=60 <=75	Supplier may carry out suggested improvements if advised by MISCC Supplier's visit is mandatory. Trial/ Development code may be given.
4.	Less than 60	Not to be registered

Note: Indian Stockist/ Trader/ Distributor/ Dealer/ Authorised Agent/ Channel partner/ Indian Sales office or Subsidiary of registered foreign principal are to be awarded marks on pro-rata basis and registered accordingly.

Signatures: MISCC and Suppler Evaluation Team (in case of visit)

1)

2)

3)

4)

5)

6)

BHEL CERTIFIED ASSESSOR

ANNEXURE - 6

NON-DISCLOSURE AND PROPRIETARY INFORMATION AGREEMENT

BETWEEN

_____ (Name of the Vendor), having its registered offices in _____ (Address of Vendor), registered under the no. _____ of the Companies' register of _____ (Name of Place and Country), capital stock of _____ (Value), with a place of business in _____ (Name of Place and Country) (hereinafter referred to as " _____ (Name of Vendor)");

AND

Bharat Heavy Electricals Ltd a company incorporated under the Indian Companies Act 1956 having its registered offices at BHEL House, Siri Fort, New Delhi -110 049 and having one of its works at Heavy Electrical Equipment Plant, Ranipur, Haridwar-249403 (Uttarakhand), India registered under the No. 4281 of 1964-65 of the companies register of Delhi, capital stock of Rs 4895.2 million with a place of registered office in New Delhi (hereinafter referred to as "BHEL") hereinafter also referred to individually as "the Party" or collectively as "the Parties".

BACKGROUND

This Agreement sets forth the rights and obligations of the Parties with respect to the use, handling, protection and safeguarding of Proprietary Information that is disclosed by and between the Parties.

WHEREAS

A) the Parties wish to pursue exploratory discussions concerning a possible collaboration between them in relation to the Program defined in Exhibit 1;

B) during the ensuing discussions and negotiations it may occur that either Party discloses to the other technical, financial or business information of a proprietary or confidential nature, which the Parties intend to protect against, making it available, by any means to any third person, and other unauthorized use and/or further disclosure by the recipient, in accordance with the terms and conditions set forth herein;

NOW, THEREFORE, the Parties have agreed as follows:

1. The term “Proprietary Information” shall mean any information or data of whatsoever kind of a confidential or proprietary nature, including but not limited to, commercial information, know how and technical information in the form of designs, drawings, concepts, requirements, specifications, software, interfaces, components, processes, or the like, that have been or will be disclosed by either Party to the other pursuant to this Agreement, either in writing, orally or other form, which is designated as “Proprietary” or “Confidential” by the disclosing Party by means of formal declaration or an appropriate stamp, legend or any other written or orally notice .

2. Proprietary Information may be conveyed, without limitation, through any written or printed documents, samples, models, electronic form on disk, tape, other storage media or any other means of disclosing such Proprietary Information that either Party may elect to use during the life of this Agreement, but if an originating Party originally discloses information orally or visually, the receiving Party will protect such information as Proprietary Information to the extent that the originating Party :
 - identifies the Information as Proprietary at the time of original disclosure,
 - summarizes the Proprietary Information in writing .

Information stored in electronic form on disk, tape, other storage media will be adequately marked if a proprietary legend displays when the information originally runs on a computer system and when the information is printed from its data file.

Proprietary Information also includes any information which can be obtained by examination, testing or analysis of any hardware or material substance or any component part of such hardware or material substance provided by the Disclosing Party even though the requirements in Clause 1 for marking and designation have not been fulfilled.

3. Each Party, to the extent of its rights to do so, shall disclose to the other only the Proprietary Information which the disclosing Party deems appropriate to fulfil the objectives of this Agreement. The Parties hereby represent that the disclosure of Proprietary Information by and between themselves shall be made in compliance with, and subject to the laws and regulations of the Disclosing Party's country.

4. The receiving Party hereby agrees and covenants that, from the effective date of this Agreement until the expiry date as per article 11 and the following period as per article 12, the Proprietary Information that either Party receives from the other shall:
 - a) be protected and kept in strict confidence by the receiving Party which must use the same degree of care it uses to protect its own confidential information and in no case less than a reasonable care;

 - b) be only disclosed to and used by those persons within the receiving Party's organization or that of its parent or controlled companies who have a need to know and solely for the purposes specified in this Agreement, and be treated by such persons or entities with the same degree of care and subject to the same restrictions;

 - c) to procure that each third party to whom Proprietary Information is disclosed under this Agreement is made aware of the provisions of this Agreement prior to such disclosure to it and that each such third party is

bound by obligations of confidentiality which are no less onerous than those contained in this Agreement;

- d) neither be disclosed nor caused to be disclosed or made available, either directly or indirectly, to any third Party or persons other than those mentioned in subparagraph b) above or other persons upon which both of the contractual Parties shall agree in an amendment to this Agreement;
- e) not to copy, reproduce or reduce to writing any part of such Proprietary Information except as may be reasonably necessary for the purpose referred to in the Recitals of this Agreement

PROVIDED THAT the Receiving Party shall be entitled to make any disclosure required by court order or government or regulatory requirement of the Disclosing Party's Proprietary Information subject to notifying the Disclosing Party as soon as possible of such requirement

- 5. Any Proprietary Information and copies thereof disclosed by either Party to the other shall remain the property of the disclosing Party and shall be immediately returned or destroyed by the receiving Party upon request.
- 6. The receiving Party shall have no obligations or restrictions with respect to any Proprietary Information for which the receiving Party can prove that:
 - a) is in or which comes into the public domain otherwise than as a result of a breach of this Agreement by any person to whom a disclosure of Proprietary Information is made as permitted under this Agreement or of any other duty of confidentiality relating to the Proprietary Information of which the Receiving Party has knowledge; or
 - b) it has been in its possession without restriction at the time of the disclosure, as evidenced by written documentation in its files; or
 - c) it has been lawfully received from a third Party without breach of this Agreement; or

- d) it has been or is published without violation of this Agreement; or
 - e) it has been independently developed in good faith by employees of the receiving Party who did not have access to the Proprietary Information; or
 - f) it has not been properly declared, designated or confirmed as Proprietary or Confidential; or
 - g) the protection period has expired according to articles 11 and 12 of this Agreement.
7. With respect to any exchange of Proprietary Information which may occur as a result of this Agreement, it is expressly understood and agreed that the persons listed in Exhibit 2 shall, on behalf of the respective Parties, be the exclusive individuals authorized to receive from and transmit to the other Party Proprietary Information under this Agreement. Each Party may replace at any time its respective authorized individuals identified in such Exhibit 2, within its own organization. Any such new designation by a Party shall be made by written notice to the other at the address indicated in such Exhibit 2.
8. Any Proprietary Information which is identified as "Classified Information", or whose export is subject to an export license, shall be identified as such by the disclosing Party at the time of disclosure and the disclosure, protection, use and handling thereof, shall remain subject to the security procedures and restrictions imposed by the disclosing Party's Government.
9. The disclosure of Proprietary Information under this Agreement by either Party to the other shall not be construed as granting to the receiving Party any right, whether express or implied by licence or otherwise, on the matters, inventions or discoveries to which such information pertains, or as granting any trademark, patents, copyrights, trade secret right or other form of intellectual property right.

10. Nothing in this Agreement may be construed as an obligation of either Party to disclose any Proprietary Information to the other, or to enter into any subsequent contractual relationship with such other Party.
11. This Agreement covers the exchange of Proprietary Information which may be made by either Party to the other until ten years from signing of the agreement or any extension thereto which may be agreed upon by the Parties in writing. Proprietary information relevant to the Program detailed in Exhibit 1, already made available to the other contractual Party before the effective date, shall also be protected under this Agreement.

It is understood by the parties that, prior to disclosure, the Disclosing Party shall have obtained any government authorization needed for the export of the Proprietary Information

12. The expiry of the period contemplated in Article 11 of this Agreement shall not relieve the receiving Party from complying with the obligations imposed by Article 4 here above with respect to the use and protection of the Proprietary Information, received prior the date of such expiry, for a period of ten (10) years after such expiry.
13. The Parties are independent contractors. Each will bear all costs and expenses in connection with this Agreement. This Agreement is intended to facilitate only the exchange of Proprietary Information and is not intended to be, and shall not be construed to create a teaming agreement, joint venture, association, partnership, or other business organization or agency arrangement and no Party shall have the authority to bind the other without the other Party's separate prior written agreement .
14. This Agreement shall be governed by and shall be interpreted in accordance with the substantive federal laws of Switzerland excluding it's choice of law rules.

Irrespective of the foregoing each Party shall remain bound by the provisions of its own national laws and regulations with respect to the transfer or use of Classified Information or information whose export is subject to an export license.

15. All disputes among the Parties, in connection with or arising out of the existence, validity, construction, performance and termination of this Agreement (or any terms thereof), which the Parties are unable to resolve among themselves, shall be finally settled by an Arbitration. The Arbitration shall be held in Geneva (CH) in English language, in accordance with the rules of the ICC – International Chamber of Commerce by three arbitrators appointed in accordance with said rules.
16. The foregoing constitutes the entire Agreement among the Parties with respect to the subject matter hereof and supersedes and cancels all prior representations, negotiations, commitments, undertakings, communications, either oral or written, acceptances, understandings and agreements among the Parties with respect to or in connection with any of the matters to which such Agreement applies or refers.
17. Notices to _____(**Name of Vendor**) shall be made at the following address:

(Complete Address of Vendor)

Attention: Mr. _____(**Name of the Authorized Person of Vendor**)

Notices to BHEL shall be made at the following address:

BHARAT HEAVY ELECTRICALS LIMITED,
HEAVY ELECTRICAL EQUIPMENT PLANT,
Ranipur, Haridwar-249403 (Uttarakhand), India

Attention: Shri B.M.Bansal, General Manager- Materials Management

18. The effective date of this Agreement shall be the date of the last signature appearing herein.

IN WITNESS WHEREOF, each of the Parties has caused this Agreement, to be executed by its duly authorized officer.

Date :

Signed for and on behalf of

Signed for and on behalf of

(Name of Vendor)

BHEL

By:

By:

Title:

Title:

Signature:

Signature:

EXHIBIT 1

to the

NON-DISCLOSURE AGREEMENT

between

_____ **(Name of Vendor)**

and

BHARAT HEAVY ELECTRICALS LIMITED

dated:

The Non Disclosure Agreement covers the exchange of Proprietary Information which may occur during the discussions and negotiations in view of a possible cooperation between the Parties in the following programs:

-Description of Material or Services for which the order is placed

_____ **(Name of Vendor)** list of products that require an exchange of Proprietary Information which may be occur during the discussions and negotiations in view of a possible cooperation for the above programs :