



BHARAT HEAVY ELECTRICALS LIMITED
HEEP HARIDWAR INDIA-PIN 249403
FAX NO: 0091 1334 226462
PHONE NO: 0091 1334 284593

Enq. No.: L/6455/4/6161Y/1
M/S.....

Sub: BHEL-HEEP/OPEN-TENDER (TL)/2015

Dear Sir,

The Heavy Electricals Equipment Plant (HEEP) located in Haridwar, India is one of the major manufacturing plants of Bharat Heavy Electricals Ltd. The core business of HEEP includes design and manufacture of large steam and gas turbines, turbo generators and so on.

Sealed tenders with the Tender No. and opening date clearly super scribed on the cover are invited from the manufacturers (registered as well as unregistered) for the supply of the following items:-

The tender documents is to be downloaded from our web site www.bhel.com or www.bhelhwr.co.in or www.tenders.gov.in.

Description of Items	Qty (nos.)	LOT NO.	LOT QTY.	Delivery Schedule	Opening Date
1. AAA814105645 PLATE GAUGE FOR NECK WIDTH = 17.7 + 0.110 (GO- NOGO) DRG.NO.-R8141-0564	2	1	2		
2. AAA814105653 PLATE GAUGE FOR NECK WIDTH = 18.0 + 0.110 (GO- NOGO) DRG.NO.-R8141-0565	2	1	2		
3. AAA814105661 PLATE GAUGE FOR NECK WIDTH = 21.6 + 0.130 (GO- NOGO) DRG.NO.-R8141-0566	2	1	2	30.06.16	25.04.2016
4. AAA814105670 PLATE GAUGE 22.2 DRG.NO.-R8141-0567	2	1	2		
5. AAA814105688 PLATE GAUGE 22.5 DRG.NO.-R8141-0568	2	1	2		
6. AAA814105696 PLATE GAUGE DRG.NO.-R8141-0569	2	1	2		

7. AAA814100163 PLATE GAUGE DRG.NO.-R8141-0016	4	1	4		
8. AAA814100260 PLATE GAUGE DRG.NO.-R8141-0026	4	1	4		
9. AAA814100317 PLATE GAUGE DRG.NO.-R8141-0031	4	1	4		
10. AAA814101267 PLATE GAUGE DRG.NO.-R8141-0126 REV.-01	4	1	4	30.06.16	25.04.2016
11. AAA814101356 PLATE GAUGE DRG.NO.-R8141-0135	4	1	4		
12. AAA814101364 PLATE GAUGE DRG.NO.-R8141-0136	4	1	4		
13. AAA810201968 SNAP GAUGE DRG.NO.-R8102-0196	4	1	4		
14. AAA810201976 SNAP GAUGE DRG.NO.-R8102-0197	4	1	4		
15. AAA810201984 SNAP GAUGE DRG.NO.-R8102-0198	4	1	4		
16. ABB810201950 SNAP GAUGE DRG.NO.-R8102-0195	4	1	4		
17. ABB814101437 PLATE GAUGE DRG.NO.-R8141-0143	4	1	4		
18. AAA815100795 DEPTH GAUGE DRG.NO.-R8151-0079	4	1	4		

19. AAA810202409 LIMIT GAUGE 10H6 FOR CHECKING T-GROOVE OF END SEALINGS DRG.NO.-R8102-0240	4	1	4		
20. ABB815900872 BURR GUAGE DGR NO.R8159-0087 TYPE-IREV. 03	2	1	2	30.06.16	25.04.16
21. ABC815900872 BURR GUAGE DRG. NO. R8159-0087 TYPE-IIREV. 03	2	1	2		
22. ABD815900872 BURR GUAGE DRG NO.R8159-0087 TYPE-IIIREV. -03	2	1	2		

The date for opening of tender shall be 25.04.16. Tenders will be received in tender box kept at Main ADM building, HEEP – BHEL Ranipur, Haridwar – 249403 Uttarakhand (INDIA) up to 1.45 P.M. on 25.04.16 and opened on the same day at 2.00 P.M. in the Tender Room. **Please note that tender received after due date & time (1.45PM on 25.04.16) will not be REPEAT will not be opened.** BHEL will not be responsible for any type of delay due to postal / courier etc. and it shall be the responsibility of vendor to submit offer in time in tender box.

Specifications & Drawing of the above items are available on our above website with links provided for all Specifications, Drawings & Annexure (At the end of this document). Amendments/Corrigendum, if any, will be hosted on our web site only. Other terms and conditions will be as per tender documents.

Please submit your offer for the above requirement subject to our terms and conditions.

The tender document must comprise of three envelopes:

1. Envelope I: Pre- Qualification Requirement (Annex. 2) , SRF

The SRF duly filled up will be assessed for manufacturing capability quality systems being followed, organizational soundness and financial worthiness. The same shall be submitted with Part-I by un-registered vendor only with BHEL, HEEP, Haridwar. The un-registered bidder shall submit inter alia duly filled in supplier registration form (SRF) along with the bid. Bidder can download the SRF from www.bhel.com

BHEL registered vendors (registered with permanent code M, N, S) need not to submit SRF.

For vendors registered with T code, SRF is to be submitted essentially along with the offer.

2. Envelope II: Techno-Commercial Bid, Annex. 3, Non-disclosure agreement as per Annexure 6, NSIC certificate or other supporting document in case of MSE vendors (to avail the MSE benefits, if applicable).
3. Envelope III : Price Bid

BIDS shall be opened at 2 PM on the due date in the presence of authorized representative of the bidders who may like to be present. The authorized representative should bring authority letter from their parent company (Manufacturer) for attending the bid opening.

KINDLY READ “INSTRUCTIONS TO BIDDERS.” QUOTATION NOT IN ACCORDANCE WITH THE INSTRUCTIONS ARE LIABLE TO BE DISQUALIFIED AND IGNORED.

INSTRUCTIONS TO BIDDERS FOR OPEN TENDER

1.0 DEFINITION

Registered Vendors - Are those who are registered with BHEL, Haridwar for Megawatt rating/ Size/ Weight of tendered items in respective material grade or machining of such items.

Un-registered Vendors - Are those who are not registered with BHEL, Haridwar for Megawatt Rating / Size/ Weight of tendered items in respective material grade or machining of such items.

2.0 ESSENTIAL INSTRUCTIONS

1. Un-registered vendors may be approved by BHEL, if found suitable, on the basis of data furnished by them in Supplier Registration Form (SRF) for Foreign Vendors or Indigenous Vendors (as applicable).
2. BHEL team may visit the vendor (s) works for verification of capability and capacity claimed in tender documents/offer (s).
3. The tenders shall be submitted in three parts in separate sub-envelopes clearly super scribing type of bid, tender no., due date and the name of vendor with full contact details.
 - i. Part I –Pre- Qualification requirement (Annex.2) & Supplier Registration Form (if Applicable)
 - ii. Part II – Techno- Commercial Bid, NSIC certificate or other supporting document in case of MSE vendors (to avail the MSE benefits), Annex. 3, Non-disclosure agreement as per Annexure 6.
 - iii. Part III – Price Bid

All the three sub-envelopes to be put in a single covering envelope indicating tender no., due date and the name of vendor with full contact details. Offer should be complete in all respect (i.e. Part-I, Part-II and Part-III).

4. Please quote your rates with both the options (a) C&F Landing port & (b) FOB dispatching port for foreign vendors. In case of FOB dispatching port, BHEL will add sea freight, insurance and administrative charges for comparison purpose. The offers of vendors not quoting FOB prices in their offers submitted through tender room shall not be considered and will stand rejected out rightly (except high sea sales case).
5. Please quote your rates in your currency or Indian Rupees.
6. Indian Agents commission if payable shall be converted to Indian Rupees at TT buying rates of exchange ruling on tender opening date (part 1) which shall not be subjected to any further exchange rate variation.
7. The vendor must indicate the name of port of loading in their offer.
8. While submitting your bids please clearly indicate:
 - (a) Expected Weight of goods (lots wise).
 - (b) The size of packed goods.
 - (c) Whether the goods can be dispatched in containers?
9. As per the Indian Law, all consignments being imported into India by air/sea require a phytosanitary certificate from the country of origin-if articles have been packed with packaging materials. This is mandatory.
 - Packaging material means any kind of material of plant origin used for Packing which include hay, straw wood shavings, wood chips, saw dust, wood waste, wooden pallets, dunnage mats, wooden packages, coir pith, peat or sphagnum moss etc.
 - Please confirm in your offer/despatch documents that the required phytosanitary certificate will be submitted.
10. The Trans-shipment condition in BHEL purchase orders / Letter of Credit will be governed by Uniform Customs and Practices for Documentary Credits, UCP 500 of International Standard Bank Procedures issued by the International Chamber of Commerce (ICC). Please refer to our web site www.bhelhwr.co.in under the heading "TRANS-SHIPMENT".
11. Specifically confirm your agreement to air freight the material at your cost in case the delivery is delayed beyond 4 weeks. It is in addition to the penalty for delayed delivery as per the printed clause overleaf.

12. The offer should be accompanied with relevant copies of catalogues, drawings or specification. If these documents are not furnished the offer is liable to be rejected.
13. For evaluation, exchange rates (TT selling rates of SBI) as on scheduled date of tender opening (part 1) shall be considered.
14. Please quote your rates on FOR destination basis only for Indian vendors. Quotations on other than FOR destination basis are liable to be rejected. However, the insurance will be arranged by BHEL.
15. BHEL will deal directly with the manufacturers and no correspondence with the agents will be entertained. The agents will not be permitted to visit/ interact with BHEL on behalf of their principals. Subsequently also no correspondence of any type will be made with any agent. All individuals/ companies representing/ Advisor/retainer ship basis or claimed to be part time employee for many OEMs/claiming to be channel/business partner for BHEL work/stockist not registered specifically etc are Agents
16. It may also be noted that documents submitted with the offer/bid by the bidder (original registered supplier) **shall be ink signed and stamped in each page** by authorized representative of the bidder. Documents not signed and stamped in each page by the authorized signatory of the bidder, shall not be accepted and considered for evaluation of the bid.
17. However, the suppliers or their authorized representatives may be allowed to attend tender opening if duly authorized by their principals, through a specific letter for a particular enquiry, for price bid opening on that particular day. General authorization letter is not acceptable.
18. As per directives of CENTRAL VIGILANCE COMMISSION, GOVERNMENT OF INDIA, One Agent can not represent two or more suppliers or quote on their behalf in a particular tender. If so found at any stage, BHEL-Hardwar is likely to cancel Enquiries/P.O.s to such suppliers. Further such Indian Agents are likely to be de-listed (Black listed for business from BHEL).
19. RISK PURCHASE: In case of delays in supplies / defective supplies or non- fulfillment of any other terms and conditions given in Purchase Order the purchaser may cancel the Purchase Order in full or part thereof, and may also make the purchase of such material from elsewhere / alternative source at the risk and cost of the supplier. Vendors do not agree to the above RISK PURCHASE CLAUSE and in eventuality of RISK PURCHASE, may be banned for business with BHEL.
20. All bank guarantees for Security Deposit as well as Performance Bank Guarantee should be from one of the BHEL consortium banks and the bank guarantee should be in the proforma as prescribed by BHEL. The proforma of bank guarantee and the list of consortium banks is displayed at BHEL website www.bhelhwr.co.in . However, in case the bank guarantee is not from BHEL consortium banks, then the vendor has to get the bank guarantee confirmed from one of the BHEL consortium banks and the bank charges are to be borne by the bidder. If any vendor does not accept this condition, their offer is likely to be ignored.
21. BHEL reserves rights to place order for tendered quantity on more than one vendor.
22. In case you are not quoting, please send your regret letter positively for our reference.
23. Intimate your email address or changes, if any, by email to candy@bhelhwr.co.in giving your Vendor Code.
24. The vendor shall have to pay 5% incidental charges while taking back supplied material if it is found rejected on receipt. The rejected material shall be sent back only after receipt of replacement.
25. Following information is available on Business-to-Business Portal on website www.bhelhwr.co.in : 1 Tender Submission, 2 Comparative Statement of Rates, 3 Status of tender enquiries, 4 Negotiations, 5 Status of purchase orders, 6 Pink Memos, 7 Rejection 8 Payment Status and 9 Vendor Registration. The user ID & password can be obtained from website itself.

26. Please resolve your rejections and unexecuted overdue purchase orders immediately which are posted at website.
27. Please confirm that prices quoted are not more than the prices quoted any other BHEL unit.
28. Where ever national/international (N/IN) standards are referred, the latest N/IN standard & are to be followed. Mention year & date of standard revision that shall be followed for the supply.
29. Kindly quote your prices in figures and words both. In case of any discrepancy in value, the prices quoted in words shall be considered for evaluation and establishing L1 status
30. TENDERS RECEIVED AFTER THE SPECIFIED TIME OF THEIR 'SUBMISSION' WILL BE TREATED AS LATE TENDERS AND SHALL NOT BE CONSIDERD UNDER ANY CIRUMSTANCES
31. The offers of the bidders who are on the banned list as also the offers of the bidders, who engage the services of the banned firms, shall be rejected. The list of banned firms is available on web site www.bhel.com
32. MSE splitting is not applicable for the items whose qty ≤ 2 nos.
33. MSE Suppliers can avail the intended benefits only if they submit along with the offer (techno commercial bid - part II), attested copies of either EM II certificate having deemed validity (five years from the date of issue of acknowledgement in EM II) or valid NSIC certificate or EM II certificate along with attested copy of a CA certificate (Format enclosed at annexure-1 where deemed validity of EM II certificate of five years has expired) applicable for the relevant financial year (latest audited). Date to be reckoned for determining the deemed validity will be the date of bid opening (Part 1 in case of two part bid). Non submission of such documents will lead to consideration of their bid at par with other bidders. No benefit shall be applicable for this enquiry if any deficiency in the above required documents is found or the requisite documents are not submitted before price bid opening. If the tender is to be submitted through e-procurement portal, then the above require document are to be uploaded on the portal. Documents should be notarized or attested by a Gazette officer.
34. Any new supplier will be eligible for registration with BHEL as MSE supplier provided at least any one of the following documents are submitted along with application for registration :-
 - a. Valid NSIC Certificate or
 - b. Entrepreneurs Memorandum part II (EM II) certificate (valid based on deemed validity of 5 years) or
 - c. EM II certificate along with attested copy of CA Certificate (as per prescribed format at annexure 1) applicable for the relevant financial year (latest audited), where the deemed validity of EM II is over. However, credentials of all MSE supplier will be verified before advancing the intended benefits.
35. MSE vendors claiming SC/ST status will have to submit SC/ST certificate of the Proprietor from competent authority. Attested (notarized or attested by Gazetted officer) copy to be submitted alongwith the offer.
36. In case techno-commercial accepted vendors include MSE source and their prices (based on landed cost to BHEL) are within the price band of 15% w.r.t. L-1 vendor, then BHEL can offer 20% of quantity of respective item (rounded off to nearest number) to MSE vendors at L-1 price and in case, more than one MSE vendor is in 15 % band and the same is accepted by more than one MSE vendors then 20% quantities of respective items will be considered for ordering on proportionate basis amongst MSE vendors.
37. While distributing the 20% quantity amongst MSE vendors the decimal points in quantity shall be ignored for all the vendors except the L-1 amongst MSE vendors. Balance quantity after allocating the quantity to other MSE vendors ignoring the quantities in decimal , shall be given to L-1 (amongst MSE) vendor. However if there are more than one MSE vendor at the same price level than preference for additional quantities due to ignoring off the decimal (as mentioned above) shall be given to the vendor offering favorable terms to BHEL and if the conditions offered are also same then preference will be given to the vendor having high SPR rating.
38. In case there are more than one MSE vendors (with different landed cost to BHEL) within 15% price band of lowest bidder and quantity to be offered is 1 no. only, then preference shall be given to the MSE vendor with lowest landed cost .

39. In case there are more than one MSE vendors (with same landed cost to BHEL) within 15% price band of lowest bidder and quantity to be offered is 1 no. only, then preference shall be given first, based on the favorable terms in the bid and in case terms are also same, the vendor with high SPR rating shall be given preference.
40. If L1 vendor is MSE vendor, entire quantity will be given to such MSE vendor only.
41. The Quotation should be from the Principal / Original Manufacturer, failing which the quotation is likely to be ignored. In Case the quotation is submitted through agent, the quotation must accompany specific authorization letter from the principal.
42. Any corrections / amendments shall be properly & fully authenticated with signature. No overwriting is acceptable.
43. Compliance of technical/ commercial terms and conditions as per Annexure-3
44. Part II containing Techno -Commercial Bid may be opened for those vendors who have qualified in the Part I. Price Bids (Part III) may be opened at a later date of only those bidders whose techno-commercial bid (Part II) has been found acceptable.
45. Delivery schedule is as per our requirement however delivery is not sacroscent & vendor to quote best possible lead time from the date of placement of purchase order. Offers of those vendors may not be considered if it is not found suitable to BHEL requirement.
46. Currency exchange rate will be applicable on the date of opening of Techno-commercial Bid for evaluation purpose.
47. BHEL reserves the right to split order on more than one vendor.
48. BHEL reserves the right to increase or decrease the tender quantities. Vendor should be prepared to accept order for reduced quantity without any extra charges. Vendor should also be prepared for giving quantity discount in case of increase in quantity.
49. BHEL reserves the right to reject any of all the quotations without assigning any reason thereof and no representation shall be entertained in this regard.
50. The bid shall be evaluated on landed cost to BHEL basis.
51. Total weight in Kg. & also package size essentially should be indicated.
52. BHEL will evaluate the technical bids against essential criteria/requirements. BHEL may seek clarifications, if required, from the qualified bidders only. The offers of those bidders, who are unable to respond in specified time frame, are likely to be ignored.
53. Validity of the offer shall be at least 120 days from the date of opening of techno-commercial bid.
54. LD shall be 0.5% of the total order value per week of delay or part thereof subject to a maximum of 10% of the total order value. If you do not confirm this in your offer then it shall be presumed to be acceptable.

55. SETTLEMENT OF DISPUTES

- Indigenous Vendors: In all cases of dispute the matter shall be referred for arbitration to any arbitrator to be appointed by the Executive Director or any officer who is the administrative head of Bharat Heavy Electricals Ltd., at Haridwar. The venue of arbitration shall invariably be Ranipur Haridwar. The award of the arbitrator shall be final and binding on both the parties. The arbitrator shall have the power to extend, from time to time, the time for making his award with the consent of the parties.
- Foreign Vendors: In the event of any dispute or difference arising between the parties to this contract regarding execution of same or their respective rights and liabilities there under, the same shall except as otherwise expressly provided therein, be referred to the arbitration of the two arbitrators, one to be appointed by each party; or in the case of the said arbitrators not agreeing then an umpire to be appointed by the two arbitrators in writing before entering on that reference and provisions of the Indian Arbitration Act ,1940 or any statutory notification, or re-enactment therefore and rules framed there under from time to time shall apply to such arbitration . If the two arbitrators do not agree on the appointment of umpire, the nomination of the umpire shall be done by the International Chamber of Commerce, Paris(France).The decision of arbitrators, or in case of their not agreeing, that of the said umpire shall be binding both on seller and purchaser. The venue of the arbitration invariably be New Delhi, India.

56. JURISDICTION

All question, dispute or differences arising under, out of or in connection with the purchase order shall be subject to the exclusive jurisdiction of Haridwar courts.

57. OVER RIDING CLAUSE

All stipulations made in any correspondence other than those exchanged in regards to "instruction" in our tender documents / enquiry for submission of your offer, if at all shall be void to the extent they are repugnant to the conditions contained herein above and in the purchase order.

58. FINALITY OF MANAGEMENT DECISION

At all places in the preceding clauses BHEL Management's decision shall be final.

59. Bidders have to necessarily obtain class III DSCs. Procedure for application available on www.bhel.com

60. In case of ordering against the tender, vendor should submit their invoices against goods and services immediately after supply of goods & services But not later than 30 days from the invoice date. In case of delay, Consequential losses like loss of input credit and non-availability Of concessional forms etc, shall be to the vendor account.

3.0 GENERAL INSTRUCTIONS

TECHNO-COMMERCIAL BID shall comprise of following documents:

- a. Annexure-3 for compliance of technical/ commercial terms and conditions. Techno-commercial bid shall be exact replica of price bid without prices.
- b. Complete technical offer as per specification, drawings, technical requirement and best possible lead time from the date of placement of purchase order.
- c. Non-disclosure agreement as per Annexure 6.
- d. Any additional documents (MSE documents, if applicable).

Price Bid

- a. Price bid indicating prices to be submitted as part-III of the tender.
- b. Prices shall remain firm till the execution of the order. Insurance shall be taken care by BHEL.
- c. Prices are to be written in both Figures & Words. If there is a discrepancy between words and figures, the amount in words shall prevail.

ANNEXURE – 1

Description of Items	Qty (nos.)	LOT NO.	LOT QTY.	Delivery Schedule	Opening Date
1. AAA814105645 PLATE GAUGE FOR NECK WIDTH = 17.7 + 0.110 (GO- NOGO) DRG.NO.-R8141-0564	2	1	2		
2. AAA814105653 PLATE GAUGE FOR NECK WIDTH = 18.0 + 0.110 (GO- NOGO) DRG.NO.-R8141-0565	2	1	2		
3. AAA814105661 PLATE GAUGE FOR NECK WIDTH = 21.6 + 0.130 (GO- NOGO) DRG.NO.-R8141-0566	2	1	2		
4. AAA814105670 PLATE GAUGE 22.2 DRG.NO.-R8141-0567	2	1	2	30.06.16	25.04.16
5. AAA814105688 PLATE GAUGE 22.5 DRG.NO.-R8141-0568	2	1	2		
6. AAA814105696 PLATE GAUGE DRG.NO.-R8141-0569	2	1	2		
7. AAA814100163 PLATE GAUGE DRG.NO.-R8141-0016	4	1	4		
8. AAA814100260 PLATE GAUGE DRG.NO.-R8141-0026	4	1	4		
9. AAA814100317 PLATE GAUGE DRG.NO.-R8141-0031	4	1	4		
10. AAA814101267 PLATE GAUGE DRG.NO.-R8141-0126 REV.-01	4	1	4		
11. AAA814101356 PLATE GAUGE DRG.NO.-R8141-0135	4	1	4		

12. AAA814101364 PLATE GAUGE DRG.NO.-R8141-0136	4	1	4		
13. AAA810201968 SNAP GAUGE DRG.NO.-R8102-0196	4	1	4		
14. AAA810201976 SNAP GAUGE DRG.NO.-R8102-0197	4	1	4		
15. AAA810201984 SNAP GAUGE DRG.NO.-R8102-0198	4	1	4		
16. ABB810201950 SNAP GAUGE DRG.NO.-R8102-0195	4	1	4	30.06.16	25.04.16
17. ABB814101437 PLATE GAUGE DRG.NO.-R8141-0143	4	1	4		
18. AAA815100795 DEPTH GAUGE DRG.NO.-R8151-0079	4	1	4		
19. AAA810202409 LIMIT GAUGE 10H6 FOR CHECKING T-GROOVE OF END SEALINGS DRG.NO.-R8102-0240	4	1	4		
20. ABB815900872 BURR GUAGE DGR NO.R8159-0087 TYPE-I REV. 03	2	1	2		
21. ABC815900872 BURR GUAGE DRG.NO.R8159-0087 TYPE-II REV. 03	2	1	2		
22. ABD815900872 BURR GUAGE DRG NO.R8159-0087 TYPE-III REV. -03	2	1	2		

ANNEXURE – 2

Pre-Qualifying Requirements

PRE QUALIFYING CONDITIONS		Indent No L/6455/14/6161/Y			
		REQUIRED	OFFERED	DEVIATION	REMARKS
01.01	a).Only plain gauge, snap gauge vendors who are manufacturing and supplying gauges and are presently working satisfactorily should quote. b.) Vendors with NPL/NABL certified laboratory or tie-up with NPL/NABL certified laboratory should quote. In case of tie-up party to provide Name & Address of the laboratory. This is required from all the vendors for qualification of their offer.	Vendor to accept/agree & submit details if applicable			
01.02	Name of the customer / company where similar item within tolerance of 0.003 mm has been supplied	Vendor to submit details			
01.03	Complete postal address of the customer.	Vendor to submit details			
01.04	Month & Year of previous supply of referred item.	Vendor to submit details			
01.05	Name, designation and contact details(phone number, fax number and email address) of contact person of the customer to whom referred item was supplied.	Vendor to submit details			
01.06	BHEL reserves the right to verify the information provided by vendor. In case the information provided by vendor is found to be false/ incorrect, their offers are liable to be rejected.	Vendor to accept/agree			
01.07	All the participating vendors(Only Unregistered with HEEP, BHEL) shall be required to submit Supplier Registration Form (SRF) to BHEL.	Vendor to agree/submit			

Pushdeep
(Dy.Mgr/TR)

S.K. Sharma
(Mgr- Tool Room)

B. K. Roy
(AGM - Tool Room)



ANNEXURE-3

PLEASE FILL THIS ANNEXURE & ATTACH WITH YOUR TECHNO-COMMERCIAL BID.

S.N	Description	Your Confirmation
1.	Vendor to confirm that they meet each & every clause of our specifications/Drawings.	
2.	Vendor to list out on a separate sheet any activity which is outsourced. Please furnish details of out sourced vendor.	
3.	Confirm specifically that material shall be supplied as per tender documents.	
4.	Ink signed order acceptance shall be furnished within 15 days of order placement.	
5.	For Foreign vendors: Confirm if there is any Indian agency commission included in your price. And if yes then indicate the percentage of the same.	
6.	PO No. &/OR Vendor's Emblem/Seal shall be clearly engraved on each item	
7.	Guarantee certificate is required & period of its validity will be at least one year from the date of final acceptance of material at BHEL Haridwar.	
8.	Validity: Confirm that the validity of offer (Technical/Commercial) shall be 120 days from the due date of opening of commercial bid	
9.	The prices offered must be in your currency or in Rs and for Indian vendors- FOR - CPS, HEEP, BHEL Haridwar & for foreign vendors - FOB/FCA - nearest Port/Airport.	
10.	Prices shall remain firm & fixed till execution of order	
11.	Bank charges (if any) to be borne by supplier.	
12.	The following documents shall be given while dispatching the goods. 1. Invoice 2. Packing List 3. GR/LR copy	
13.	One copy of the above (S.No. 15) shall be sent directly to Sr. Manager (FAX-Store Bill)	
14.	Right of Acceptance- BHEL reserves the right to reject any or all the quotations without assigning any reasons thereof. BHEL also reserves the right to increase or decrease the tendered quantities. Vendor should be prepared to accept order for reduced quantities without any extra charges. Vendor should also be prepared for giving quantity discount in case of increased quantities.	
15.	Payment Terms – 100% payment after receipt & acceptance of the material at BHEL Haridwar.	
16.	Delivery Schedule (Mention the schedule)	
17.	Exact amount of CST/CVD/ED or % SHOULD BE CLEARLY MENTIONED	
18.	FINAL DIMENSIONAL REPORT OF CRITICAL DIMENSIONS FROM NPL / NABL CERTIFIED LABORATORY REQUIRED.	

NON-DISCLOSURE AND PROPRIETARY INFORMATION AGREEMENT

BETWEEN

_____ (Name of the Vendor),, having its registered offices in _____ (Address of Vendor), registered under the no. _____ of the Companies' register of _____ (Name of Place and Country), capital stock of _____ (Value), with a place of business in _____ (Name of Place and Country) (hereinafter referred to as " _____ (Name of Vendor)");

AND

Bharat Heavy Electricals Ltd a company incorporated under the Indian Companies Act 1956 having its registered offices at BHEL House, Siri Fort, New Delhi -110 049 and having one of its works at Heavy Electrical Equipment Plant, Ranipur, Haridwar-249403 (Uttarakhand), India registered under the No. 4281 of 1964-65 of the companies register of Delhi, capital stock of Rs 4895.2 million with a place of registered office in New Delhi (hereinafter referred to as “BHEL”) hereinafter also referred to individually as “the Party” or collectively as “the Parties”.

BACKGROUND

This Agreement sets forth the rights and obligations of the Parties with respect to the use, handling, protection and safeguarding of Proprietary Information that is disclosed by and between the Parties.

WHEREAS

A) the Parties wish to pursue exploratory discussions concerning a possible collaboration between them in relation to the Program defined in Exhibit

B) during the ensuing discussions and negotiations it may occur that either Party discloses to the other technical, financial or business information of a proprietary or confidential nature, which the Parties intend to protect against, making it available, by any means to any third person, and other unauthorized use and/or further disclosure by the recipient, in accordance with the terms and conditions set forth herein;

NOW, THEREFORE, the Parties have agreed as follows:

1. The term “Proprietary Information” shall mean any information or data of whatsoever kind of a confidential or proprietary nature, including but not limited to, commercial information, know how and technical information in the form of designs, drawings, concepts, requirements, specifications, software, interfaces, components, processes, or the like, that have been or will be disclosed by either Party to the other pursuant to this Agreement, either in writing, orally or other form, which is designated as “Proprietary” or “Confidential” by the disclosing Party by means of formal declaration or an appropriate stamp, legend or any other written or orally notice .

2. Proprietary Information may be conveyed, without limitation, through any written or printed documents, samples, models, electronic form on disk, tape, other storage media or any other means of disclosing such Proprietary Information that either Party may elect to use during the life of this Agreement, but if an originating Party originally discloses information orally or visually, the receiving Party will protect such information as Proprietary Information to the extent that the originating Party :
 - identifies the Information as Proprietary at the time of original disclosure,
 - summarizes the Proprietary Information in writing .

Information stored in electronic form on disk, tape, other storage media will be adequately marked if a proprietary legend displays when the information originally runs on a computer system and when the information is printed from its data file.

Proprietary Information also includes any information which can be obtained by examination, testing or analysis of any hardware or material substance or any component part of such hardware or material substance provided by the Disclosing Party even though the requirements in Clause 1 for marking and designation have not been fulfilled.

3. Each Party, to the extent of its rights to do so, shall disclose to the other only the Proprietary Information which the disclosing Party deems appropriate to fulfil the objectives of this Agreement. The Parties hereby represent that the disclosure of Proprietary Information by and between themselves shall be made in compliance with, and subject to the laws and regulations of the Disclosing Party's country.

4. The receiving Party hereby agrees and covenants that, from the effective date of this Agreement until the expiry date as per article 11 and the following period as per article 12, the Proprietary Information that either Party receives from the other shall:
 - a) be protected and kept in strict confidence by the receiving Party which must use the same degree of care it uses to protect its own confidential information and in no case less than a reasonable care;

 - b) be only disclosed to and used by those persons within the receiving Party's organization or that of its parent or controlled companies who have a need to know and solely for the purposes specified in this Agreement, and be treated by such persons or entities with the same degree of care and subject to the same restrictions;

 - c) to procure that each third party to whom Proprietary Information is disclosed under this Agreement is made aware of the provisions of this Agreement prior to such disclosure to it and that each such third party is

bound by obligations of confidentiality which are no less onerous than those contained in this Agreement;

- d) neither be disclosed nor caused to be disclosed or made available, either directly or indirectly, to any third Party or persons other than those mentioned in subparagraph b) above or other persons upon which both of the contractual Parties shall agree in an amendment to this Agreement;
- e) not to copy, reproduce or reduce to writing any part of such Proprietary Information except as may be reasonably necessary for the purpose referred to in the Recitals of this Agreement

PROVIDED THAT the Receiving Party shall be entitled to make any disclosure required by court order or government or regulatory requirement of the Disclosing Party's Proprietary Information subject to notifying the Disclosing Party as soon as possible of such requirement

- 5. Any Proprietary Information and copies thereof disclosed by either Party to the other shall remain the property of the disclosing Party and shall be immediately returned or destroyed by the receiving Party upon request.
- 6. The receiving Party shall have no obligations or restrictions with respect to any Proprietary Information for which the receiving Party can prove that:
 - a) is in or which comes into the public domain otherwise than as a result of a breach of this Agreement by any person to whom a disclosure of Proprietary Information is made as permitted under this Agreement or of any other duty of confidentiality relating to the Proprietary Information of which the Receiving Party has knowledge; or
 - b) it has been in its possession without restriction at the time of the disclosure, as evidenced by written documentation in its files; or
 - c) it has been lawfully received from a third Party without breach of this Agreement; or

- d) it has been or is published without violation of this Agreement; or
 - e) it has been independently developed in good faith by employees of the receiving Party who did not have access to the Proprietary Information; or
 - f) it has not been properly declared, designated or confirmed as Proprietary or Confidential; or
 - g) the protection period has expired according to articles 11 and 12 of this Agreement.
7. With respect to any exchange of Proprietary Information which may occur as a result of this Agreement, it is expressly understood and agreed that the persons listed in Exhibit 2 shall, on behalf of the respective Parties, be the exclusive individuals authorized to receive from and transmit to the other Party Proprietary Information under this Agreement. Each Party may replace at any time its respective authorized individuals identified in such Exhibit 2, within its own organization. Any such new designation by a Party shall be made by written notice to the other at the address indicated in such Exhibit 2.
8. Any Proprietary Information which is identified as “Classified Information”, or whose export is subject to an export license, shall be identified as such by the disclosing Party at the time of disclosure and the disclosure, protection, use and handling thereof, shall remain subject to the security procedures and restrictions imposed by the disclosing Party's Government.
9. The disclosure of Proprietary Information under this Agreement by either Party to the other shall not be construed as granting to the receiving Party any right, whether express or implied by licence or otherwise, on the matters, inventions or discoveries to which such information pertains, or as granting any trademark, patents, copyrights, trade secret right or other form of intellectual property right.

10. Nothing in this Agreement may be construed as an obligation of either Party to disclose any Proprietary Information to the other, or to enter into any subsequent contractual relationship with such other Party.
11. This Agreement covers the exchange of Proprietary Information which may be made by either Party to the other until ten years from signing of the agreement or any extension thereto which may be agreed upon by the Parties in writing. Proprietary information relevant to the Program detailed in Exhibit 1, already made available to the other contractual Party before the effective date, shall also be protected under this Agreement.

It is understood by the parties that, prior to disclosure, the Disclosing Party shall have obtained any government authorisation needed for the export of the Proprietary Information

12. The expiry of the period contemplated in Article 11 of this Agreement shall not relieve the receiving Party from complying with the obligations imposed by Article 4 here above with respect to the use and protection of the Proprietary Information, received prior the date of such expiry, for a period of ten (10) years after such expiry.
13. The Parties are independent contractors. Each will bear all costs and expenses in connection with this Agreement. This Agreement is intended to facilitate only the exchange of Proprietary Information and is not intended to be, and shall not be construed to create a teaming agreement, joint venture, association, partnership, or other business organisation or agency arrangement and no Party shall have the authority to bind the other without the other Party's separate prior written agreement .
14. This Agreement shall be governed by and shall be interpreted in accordance with the substantive federal laws of Switzerland excluding it's choice of law rules.

Irrespective of the foregoing each Party shall remain bound by the provisions of its own national laws and regulations with respect to the transfer or use of Classified Information or information whose export is subject to an export license.

15. All disputes among the Parties, in connection with or arising out of the existence, validity, construction, performance and termination of this Agreement (or any terms thereof), which the Parties are unable to resolve among themselves, shall be finally settled by an Arbitration. The Arbitration shall be held in Geneva (CH) in English language, in accordance with the rules of the ICC – International Chamber of Commerce by three arbitrators appointed in accordance with said rules.
16. The foregoing constitutes the entire Agreement among the Parties with respect to the subject matter hereof and supersedes and cancels all prior representations, negotiations, commitments, undertakings, communications, either oral or written, acceptances, understandings and agreements among the Parties with respect to or in connection with any of the matters to which such Agreement applies or refers.
17. Notices to _____ (**Name of Vendor**) shall be made at the following address:

(Complete Address of Vendor)

Attention: Mr. _____ (**Name of the Authorised Person of Vendor**)

Notices to BHEL shall be made at the following address:

BHARAT HEAVY ELECTRICALS LIMITED,
HEAVY ELECTRICAL EQUIPMENT PLANT,
Ranipur, Haridwar-249403 (Uttarakhand), India

Attention: Shri B.M.Bansal, General Manager- Materials Management

18. The effective date of this Agreement shall be the date of the last signature appearing herein.

IN WITNESS WHEREOF, each of the Parties has caused this Agreement, to be executed by its duly authorized officer.

Date :

Signed for and on behalf of

Signed for and on behalf of

(Name of Vendor)

BHEL

By:

By:

Title:

Title:

Signature:

Signature:

EXHIBIT 1

to the

NON-DISCLOSURE AGREEMENT

between

_____ **(Name of Vendor)**

and

BHARAT HEAVY ELECTRICALS LIMITED

dated:

The Non Disclosure Agreement covers the exchange of Proprietary Information which may occur during the discussions and negotiations in view of a possible cooperation between the Parties in the following programs:

-Description of Material or Services for which the order is placed

_____ **(Name of Vendor)** list of products that require an exchange of Proprietary Information which may be occur during the discussions and negotiations in view of a possible cooperation for the above programs :

COPYRIGHT AND CONFIDENTIAL
 THE INFORMATION ON THIS DOCUMENT IS THE PROPERTY OF BHARAT
 HEAVY ELECTRICALS LIMITED IT MUST NOT BE USED DIRECTLY
 OR INDIRECTLY IN ANY WAY DETRIMENTAL TO THE INTEREST OF COMPANY.

FIRST ANGLE PROJECTION

(ALL DIMENSIONS ARE IN mm)

FORM DG38(B)

DRAWING No. R8141-0564

3.2/
 THE REST

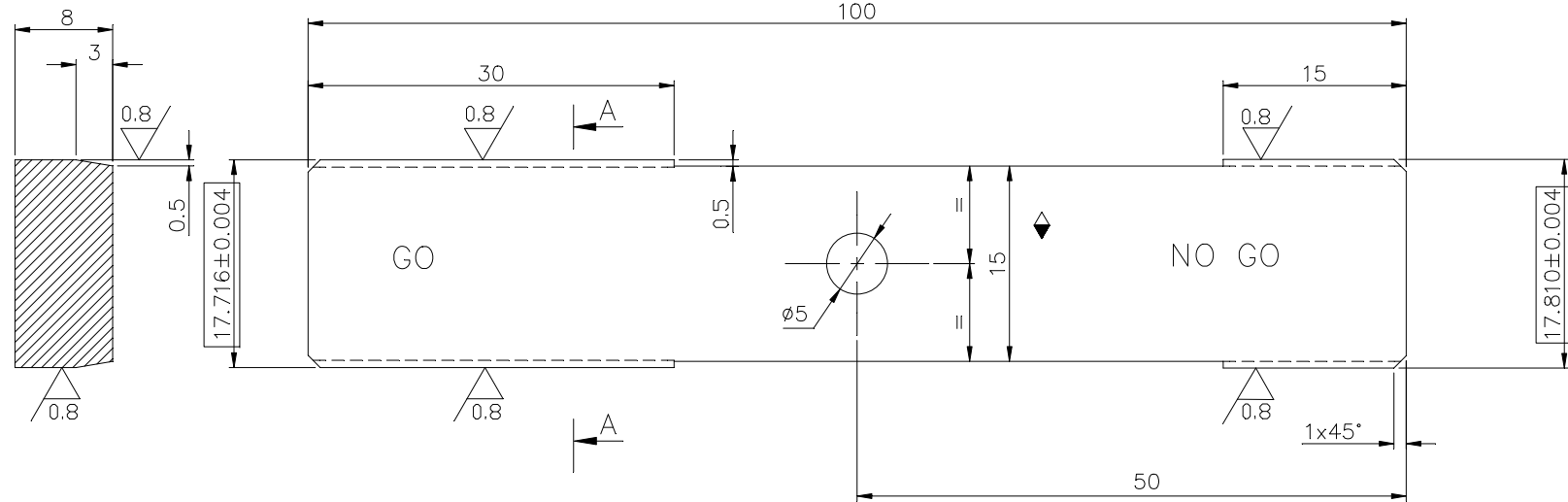

NOTES-

- 1-SHARP EDGES TO BE ROUNDED OFF.
- 2-HARDEN TO HRC 50-60 AS PER PS 0912-008.
- 3-DIMENSIONS IN ARE CRITICAL TO QUALITY(CTQ)
- 4-CONSERVATION TO BE DONE AS PER TL 30007.

◆ MARK
R8141-0564
17.7+0.110 +0
GO, NO GO

Released

INVENTORY No. SIGN.&DATE REF. DRG. No.

ITEM No.	DESCRIPTION	STD	DRAWING No.	T90Mn6WCr2 HW10892			
				MATERIAL CODE	A	UNIT	UNIT WEIGHT
				VAR. MATERIAL SPECN.	c		QTY.

GMS No./GR.SP.No.		STATUS OF DRG.		TYPE OF PRODUCT	COMP. DRG. No.	M/C TOOL TRANS No.	REF. DRG. No.
AGREED DEPT.		NAME	SIGN.	DATE	41010713011	143	R8141-0528
TTX		SURINDER	-Sd-	08.05.14	DESIGN ORDER No.	M/C MODEL No.	
					ST/6027	V.B.	
GRADE OF UNTOL. DIM.: -		NAME		SIGN.	DATE	No. OF VAR.	
M/CG- Q /M/F AA0230208		DRN		RAJESH	-Sd-	08.05.14	
WELDING-A/B/C/D AA0621104		CHD		RAVI	-Sd-	08.05.14	
GAS CUTTING-'T3' AA0621101		APD		ANKUR	-Sd-	08.05.14	
REV	DATE	ALTERED	REV	DATE	ALTERED	REF.TO ASSY. DRG.	ITEM No. OF
		CHECKED			CHECKED		No. ITEMS
							--
DEPT. JTE				SCALE	WEIGHT(Kg)	REF. TO ASSY. DRG.	
CODE 209				NTS	~0.11	DRAWING No.	
						R8141-0564	
TITLE				DRAWING No.		REV.	
PLATE GAUGE FOR NECK				R8141-0564			
WIDTH=17.7+0.110 (GO-NOGO)				SHEET No. 01		No. OF SHEETS 01	

SIZE A 3

COPYRIGHT AND CONFIDENTIAL
 THE INFORMATION ON THIS DOCUMENT IS THE PROPERTY OF BHARAT
 HEAVY ELECTRICALS LIMITED. IT MUST NOT BE USED DIRECTLY
 OR INDIRECTLY IN ANY WAY DETRIMENTAL TO THE INTEREST OF COMPANY.

FIRST ANGLE PROJECTION

(ALL DIMENSIONS ARE IN mm)

FORM DG38(B)

DRAWING No. R8141-0566

3.2/
THE REST

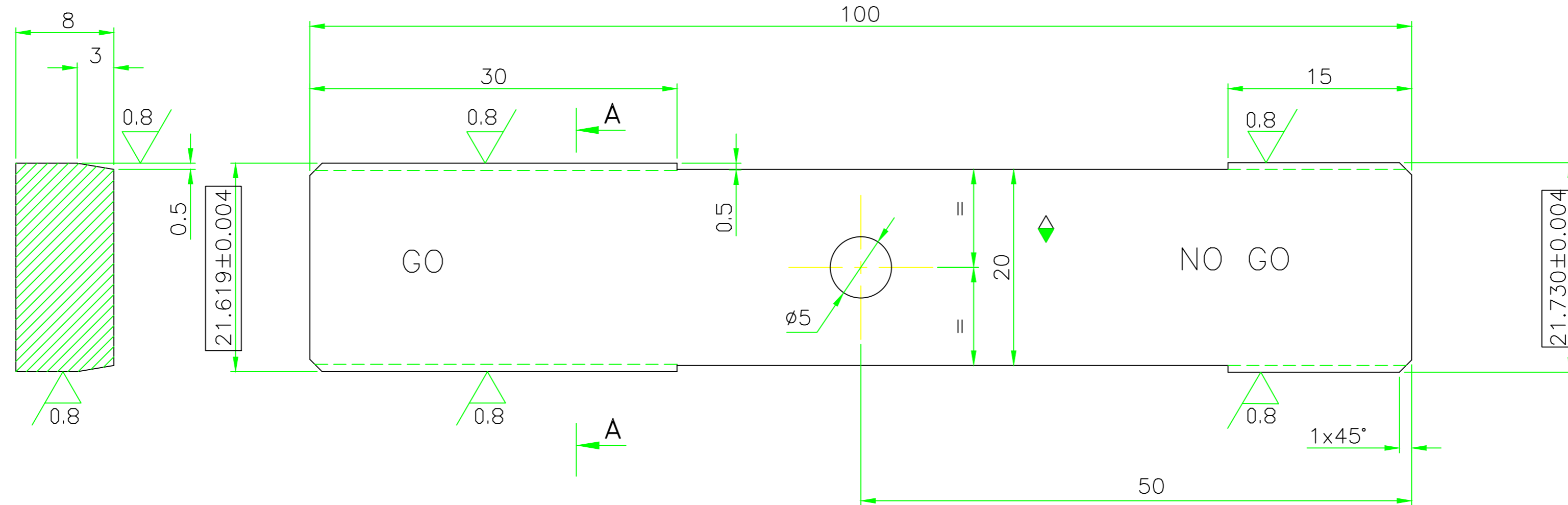

	MARK
R8141-0566	
21.6+0.130	
+0	
GO,	NO GO

NOTES-

- 1-SHARP EDGES TO BE ROUNDED OFF.
- 2-HARDEN TO HRc 50-60 AS PER PS 0912-008.
- 3-DIMENSIONS IN ARE CRITICAL TO QUALITY(CTQ)
- 4-CONSERVATION TO BE DONE AS PER TL 30007.

ITEM No.	DESCRIPTION	STD	DRAWING No.	T90Mn6WCr2	HW10892	MATERIAL CODE	A	UNIT	QTY.
						MATERIAL SPECN.	C		

GMS No./GR.SP.No.	STATUS OF DRG.	TYPE OF PRODUCT	COMP. DRG. No.	M/C TOOL TRANS No.	REF. DRG. No.
TTX	08.05.14	ST 228MW	41010713013	143	R8141-0528
AGREED DEPT.	NAME	SIGN.	DATE	DESIGN ORDER No.	M/C MODEL No.
TTX	SURINDER	-Sd-	08.05.14	ST/6029	V.B.

GRADE OF UNTOL. DIM.:-	
M/CG- C/M/F	AA0230208
WELDING-A/B/C/D	AA0621104
GAS CUTTING-'T3'	AA0621101

BHARAT HEAVY ELECTRICALS LTD.
HARDWAR

NAME	SIGN.	DATE	No. OF VAR.
DRN RAJESH	-Sd-	08.05.14	
CHD RAVI	-Sd-	08.05.14	
APD ANKUR	-Sd-	08.05.14	

REV	DATE	ALTERED	REV	DATE	ALTERED
		CHECKED			CHECKED

DEPT. JTE
CODE 209

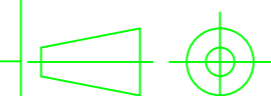

SCALE NTS
WEIGHT(Kg) ~0.14

REF.TO ASSY. DRG. ITEM No. OF No. OF ITEMS

TITLE
 PLATE GAUGE FOR NECK
 WIDTH=21.6+0.130 (GO-NOGO)

DRAWING No. R8141-0566

SHEET No. 01 No. OF SHEETS 01

SIZE A 3

INVENTORY No. SIGN.&DATE REF. DRG. No.

COPYRIGHT AND CONFIDENTIAL
 THE INFORMATION ON THIS DOCUMENT IS THE PROPERTY OF BHARAT
 HEAVY ELECTRICALS LIMITED. IT MUST NOT BE USED DIRECTLY
 OR INDIRECTLY IN ANY WAY DETRIMENTAL TO THE INTEREST OF COMPANY.

FIRST ANGLE PROJECTION

<ALL DIMENSIONS ARE IN mm>

FORM DG38(B)

DRAWING No. R8141-0567

3.2
✓ THE REST

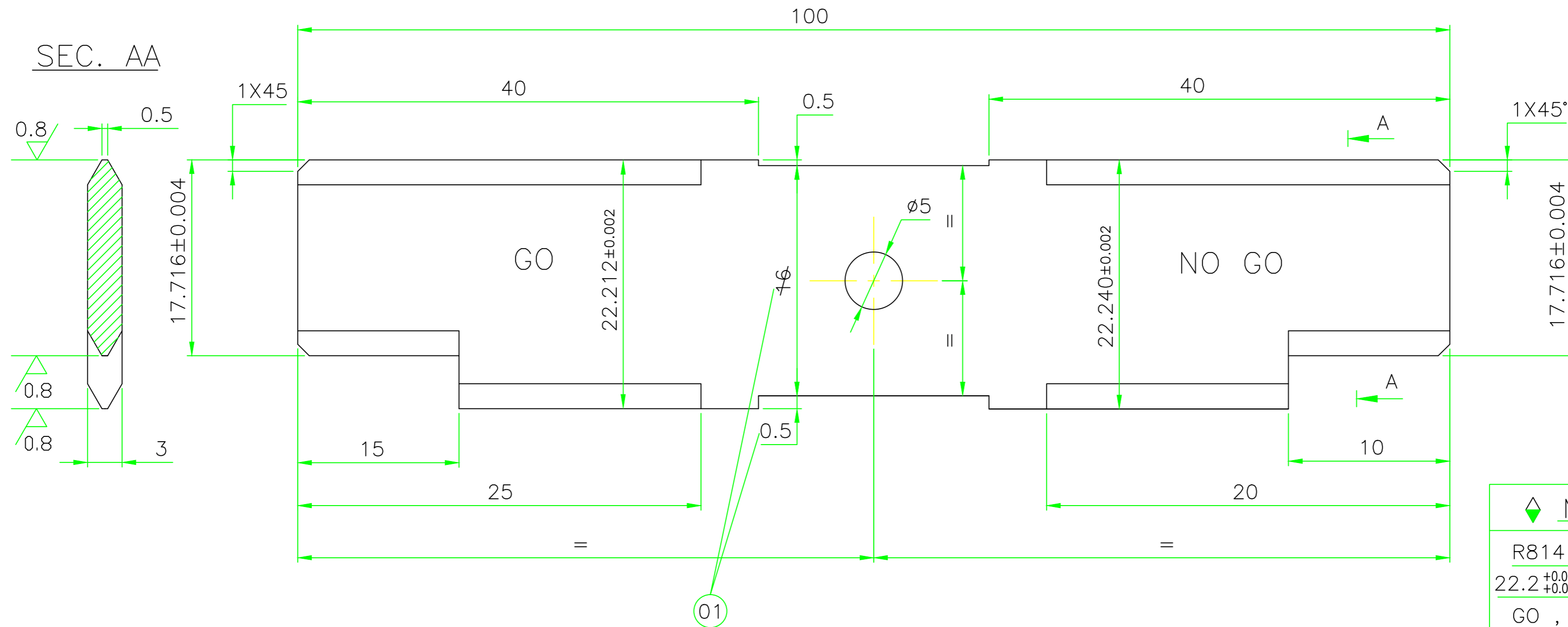

MARK
 R8141-0567
 22.2^{+0.040}/_{+0.007} / 17.7^{+0.110}
 GO , NO-GO

1-SHARP EDGES TO BE ROUNDED OFF.

2-HARDEN TO HRc 50-60 AS PER

P.S. No. 0912-008.

3-CONSERVATION IS TO BE DONE AS

PER TL-30007.

---	---	01	-----	---	T90Mn6WCr2	-	---
---	---	---	---	---	HW 10892	-	---
VAR.00	REMARKS	ITEM No.	DESCRIPTION	STD	DRAWING No.	VAR.	MATERIAL SPECN.
							MATERIAL CODE
							UNIT
							QTY.

GMS No./GR.SP.No.		STATUS OF DRG.		TYPE OF PRODUCT	COMP. DRG. No.	M/C TOOL TRANS No.	REF. DRG. No.
TTX		SURINDER -SD-		08.05.14	41010713011	143	R8141-0530
AGREED DEPT.		NAME		DATE	DESIGN ORDER No.	M/C MODEL No.	
TTE		SURINDER		08.05.14	ST/6030	V.B.	

GRADE OF UNTOL. DIM.:-	
M/CG- C /M/F	AA0230208
WELDING-A/B/C/D	AA0621104
GAS CUTTING-'T3'	AA0621101

BHARAT HEAVY ELECTRICALS LTD.
 HARDWAR

DRN	RAJESH	-SD-	08.05.14	No. OF VAR.
CHD	RAVI	-SD-	08.05.14	
APD	ANKUR	-SD-	08.05.14	

REV	DATE	ALTERED	SJTERS
		CHECKED	AJTEAM

REV	DATE	ALTERED	SJTERS
01	08.07.15	DIMENSION 16 DELETED AND DIMENSION 0.5 ADDED VIA C/A	No. JTE-15-F0069

DEPT.	JTE	SCALE	WEIGHT(Kg)
CODE	209	NTS	~0.052

REF.TO ASSY. DRG.	ITEM No.	No. OF ITEMS
-----	---	---

TITLE
 PLATE GAUGE 22.2^{+0.040}/_{+0.007} / 17.7^{+0.110}

DRAWING No.
 R8141-0567

SHEET No. 01 | No. OF SHEETS 01

SIZE A 3

INVENTORY No. SIGN.&DATE REF. DRG. No.

COPYRIGHT AND CONFIDENTIAL
THE INFORMATION ON THIS DOCUMENT IS THE PROPERTY OF BHARAT
HEAVY ELECTRICALS LIMITED. IT MUST NOT BE USED DIRECTLY
OR INDIRECTLY IN ANY WAY DETRIMENTAL TO THE INTEREST OF COMPANY.

FIRST ANGLE PROJECTION

(ALL DIMENSIONS ARE IN mm)

FORM DG38(B)

DRAWING No.
R8141-0568

3.2
✓ THE REST

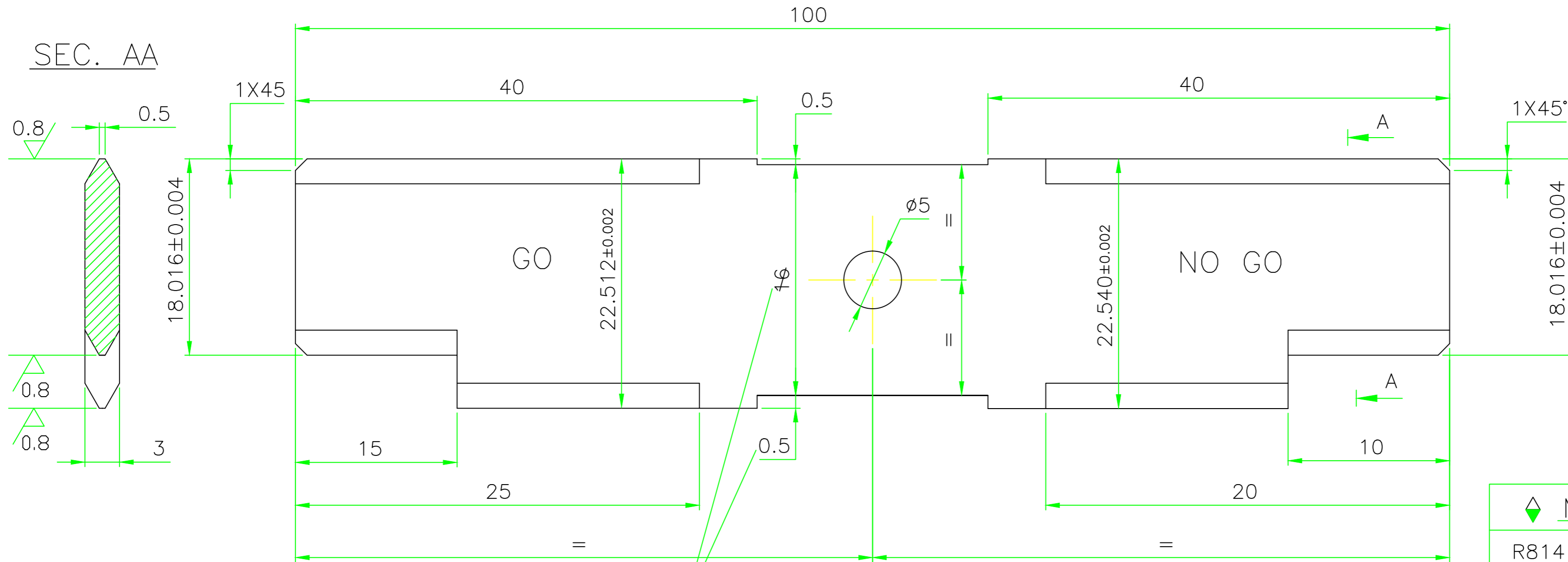

MARK
R8141-0568
22.5 ^{+0.040} / _{+0.007} / 18.0 ^{+0.110}
GO , NO-GO

- 1-SHARP EDGES TO BE ROUNDED OFF.
- 2-HARDEN TO HRc 50-60 AS PER
P.S. No. 0912-008.
- 3-CONSERVATION IS TO BE DONE AS
PER TL-30007.

---	---	01	-----	---	---	---	T90Mn6WCr2	-	---
---	---	---	---	---	---	---	HW 10892	-	---
VAR.00	REMARKS	ITEM No.	DESCRIPTION	STD	DRAWING No.		MATERIAL CODE	A	UNIT WEIGHT
							MATERIAL SPECN.	C	QTY.

GMS No./GR.SP.No.		STATUS OF DRG		TYPE OF PRODUCT		COMP. DRG. No.		M/C TOOL TRANS No.		REF. DRG. No.							
TTX		SURINDER -SD- 08.05.14		ST 228 MW		41010713012		143		R8141-0530							
AGREED DEPT.		NAME		SIGN.		DATE		M/C MODEL No.		V.B.							
TTE		SURINDER		-SD-		08.05.14		V.B.									
GRADE OF UNTOL. DIM.:-		M/CG- C /M/F AA0230208		WELDING-A/B/C/D AA0621104		GAS CUTTING-'T3' AA0621101		NAME		SIGN.		DATE		No. OF VAR.			
								DRN		RAJESH		-SD-		08.05.14			
								CHD		RAVI		-SD-		08.05.14			
								APD		ANKUR		-SD-		08.05.14			
REV		DATE		ALTERED		SJTERS		DEPT.		SCALE		WEIGHT(Kg)		REF.TO ASSY. DRG.		ITEM No. OF No. ITEMS	
				CHECKED		AJTEAM		JTE		NTS		~0.054		-----		---	
								CODE		209							
								TITLE		PLATE GAUGE 22.5 ^{+0.040} / _{+0.007} / 18.0 ^{+0.110}							
												DRAWING No.		R8141-0568		REV.	
												SHEET No. 01		No. OF SHEETS 01		SIZE A 3	

INVENTORY No. SIGN.&DATE REF. DRG. No.

E

COPYRIGHT AND CONFIDENTIAL
THE INFORMATION ON THIS DOCUMENT IS THE PROPERTY OF BHARAT
HEAVY ELECTRICALS LIMITED. IT MUST NOT BE USED DIRECTLY
OR INDIRECTLY IN ANY WAY DETRIMENTAL TO THE INTEREST OF COMPANY.

FIRST ANGLE PROJECTION

(ALL DIMENSIONS ARE IN mm)

FORM DG38(B)

DRAWING No.
R8141-0569

3.2
✓ THE REST

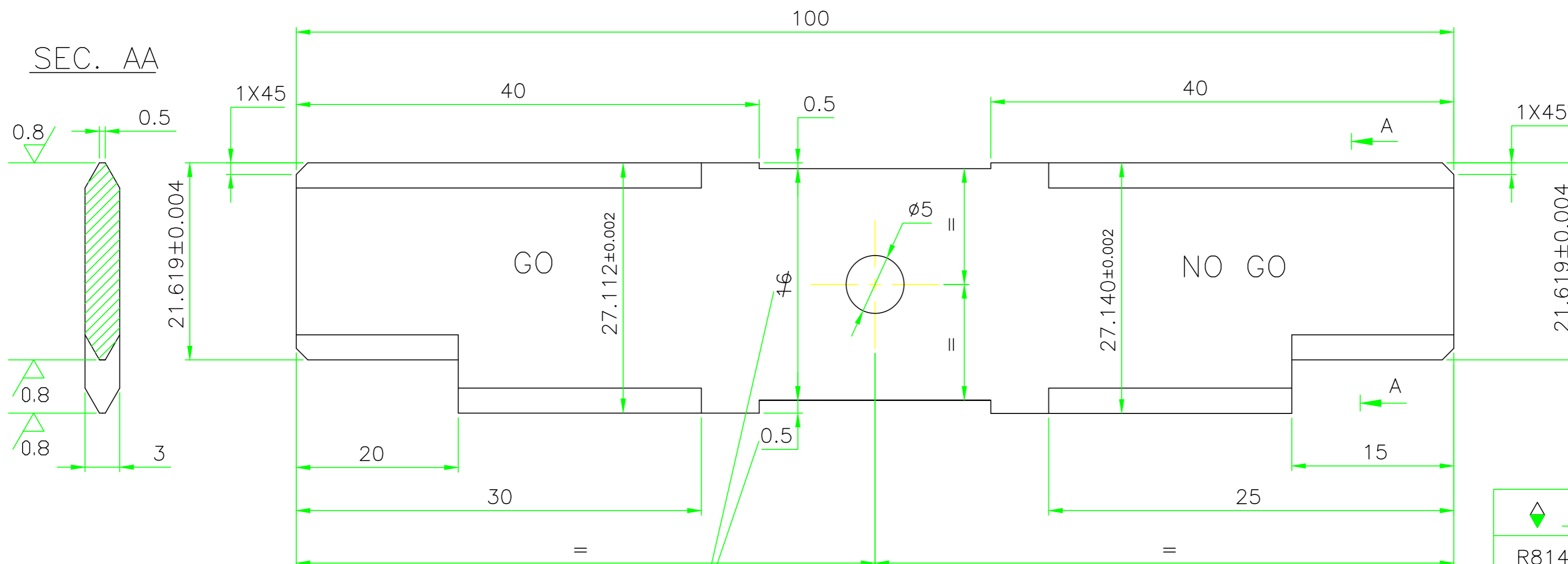

MARK
R8141-0569
27.1 ^{+0.040} / _{+0.007} / 21.6 ^{+0.130}
GO , NO-GO

- 1-SHARP EDGES TO BE ROUNDED OFF.
- 2-HARDEN TO HRc 50-60 AS PER
P.S. No. 0912-008.
- 3-CONSERVATION IS TO BE DONE AS
PER TL-30007.

---	---	01	-----	---	T90Mn6WCr2	---	---
VAR.00	REMARKS	ITEM No.	DESCRIPTION	STD	DRAWING No.	MATERIAL CODE	UNIT WEIGHT
						A	GS
						C	QTY.

GMS No./GR.SP.No.		STATUS OF DRG.	TYPE OF PRODUCT	COMP. DRG. No.	M/C TOOL TRANS No.	REF. DRG. No.
AGREED DEPT.	NAME	SIGN.	DATE	41010713013	143	R8141-0530
TTX	SURINDER	-SD-	08.05.14	ST 228 MW	M/C MODEL No.	V.B.
				DESIGN ORDER No.		
				ST/6032		

GRADE OF UNTOL. DIM.:-	
M/CG- Z /M/F	AA0230208
WELDING-A/B/C/D	AA0621104
GAS CUTTING-'T3'	AA0621101

BHEL BHARAT HEAVY ELECTRICALS LTD.
HARDWAR

DRN	NAME	SIGN.	DATE	No. OF VAR.
CHD	RAJESH	-SD-	08.05.14	
APD	RAVI	-SD-	08.05.14	
	ANKUR	-SD-	08.05.14	

REV	DATE	ALTERED	SJTERS
		CHECKED	AJTEAM
01	08.07.15	DIMENSION 16 DELETED AND DIMENSION 0.5 ADDED VIA C/A	
		No. JTE-15-F0069	

DEPT. JTE	SCALE	WEIGHT(Kg)	REF.TO ASSY. DRG.
CODE 209	NTS	~0.063	-----
TITLE			
PLATE GAUGE 27.1 ^{+0.040} / _{+0.007} / 21.6 ^{+0.130}			

DRAWING No.	ITEM No. OF
R8141-0569	NO. ITEMS

SHEET No. 01	No. OF SHEETS 01
	SIZE A 3

INVENTORY No. SIGN.&DATE REF. DRG. No.

4-525

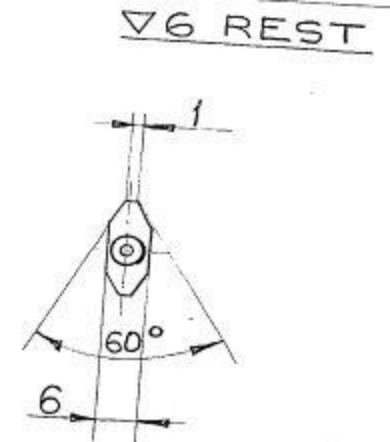
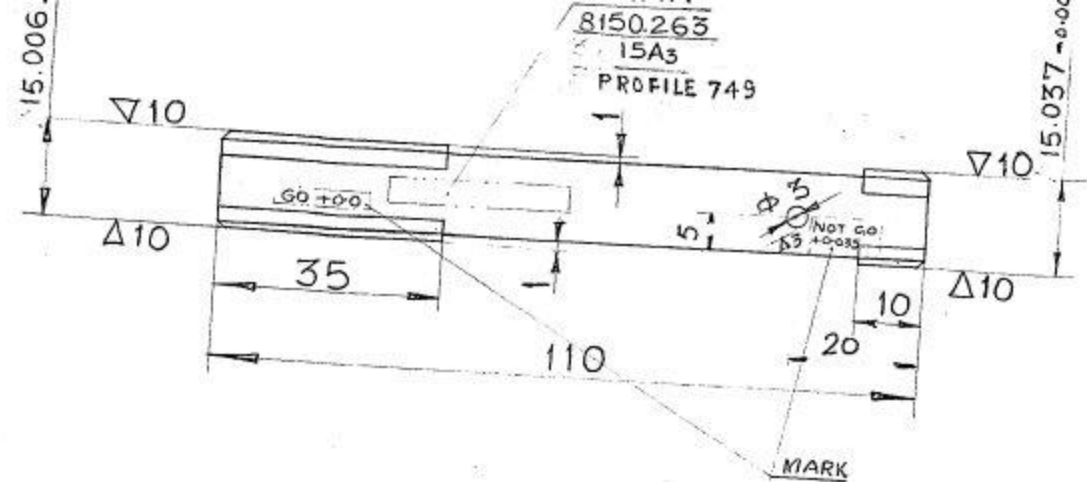

1. CARBURIZE THE WORKING SURFACES TO 0.8-1.2 MM
2. HARDEN TO HRC: 56±64

MIC TOOLEQPT	
W/O NO	ST-1332
REF. NO	A-7130803
TYPE/COMP	C-100-90 31304000 31304003

INDEX	REVISION	SIGN	DATE
DRN	S.M.PJAIN	<i>S.M.PJAIN</i>	
DGN	V.KUMAR	<i>V.KUMAR</i>	24/2
CHD	KULSHRESHT HA	<i>KULSHRESHT HA</i>	1/3/18
APPD	V.P.SINGH	<i>V.P.SINGH</i>	12/2/18
TECH	HARJITSINGH	<i>HARJITSINGH</i>	12/2/18

<p>PLATE GAUGE FOR</p> <p>15A3</p> <p>PROFILE: 749</p> <p>C-14 IS: 1570</p>		R 8141-0016	
		8150.263	
WT. IN KG	SCALE		
0.067	1:1		
JIG & TOOL	HARDWAR	B.H.E.L	

REMAINING 76

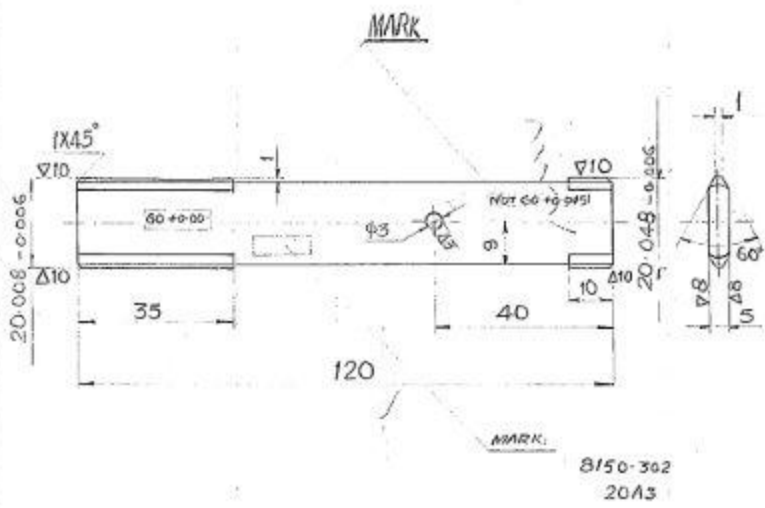

- NOTES:
1. DEPTH OF CARBURIZED LAYER AFTER GRINDING 0.8±0.2
 2. HARDEN TO HRC 56±64
 3. WEAR LIMIT OF "GO" SIDE IS 19.996

4-564

R-8141-0026

W/ORDER NO.	ST-1178
W/REF. NO.	1080801
C-10.0-0010815	10010815

INDEX NO.	REVISION	SIGN	DATE
DRN.	V. KUMAR.	[Signature]	21-3-69
DGN.	V. KUMAR.	[Signature]	
CHD.	P. KULSHRESHA	[Signature]	
APPD.	V.P. SINGH.	[Signature]	
TECHST.	HARJIT SINGH	[Signature]	

8150-302
 WEIGHT 0.095
 SCALE 1:1
PLATE GAUGE
 20A3
 PROFILE-1156
 C-14, IS-1570

8150-302
 WEIGHT 0.095
 SCALE 1:1
JIG AND TOOL
 BHSL
 HARDWAR

R 8141-0136

FORM 01.01
REST A G

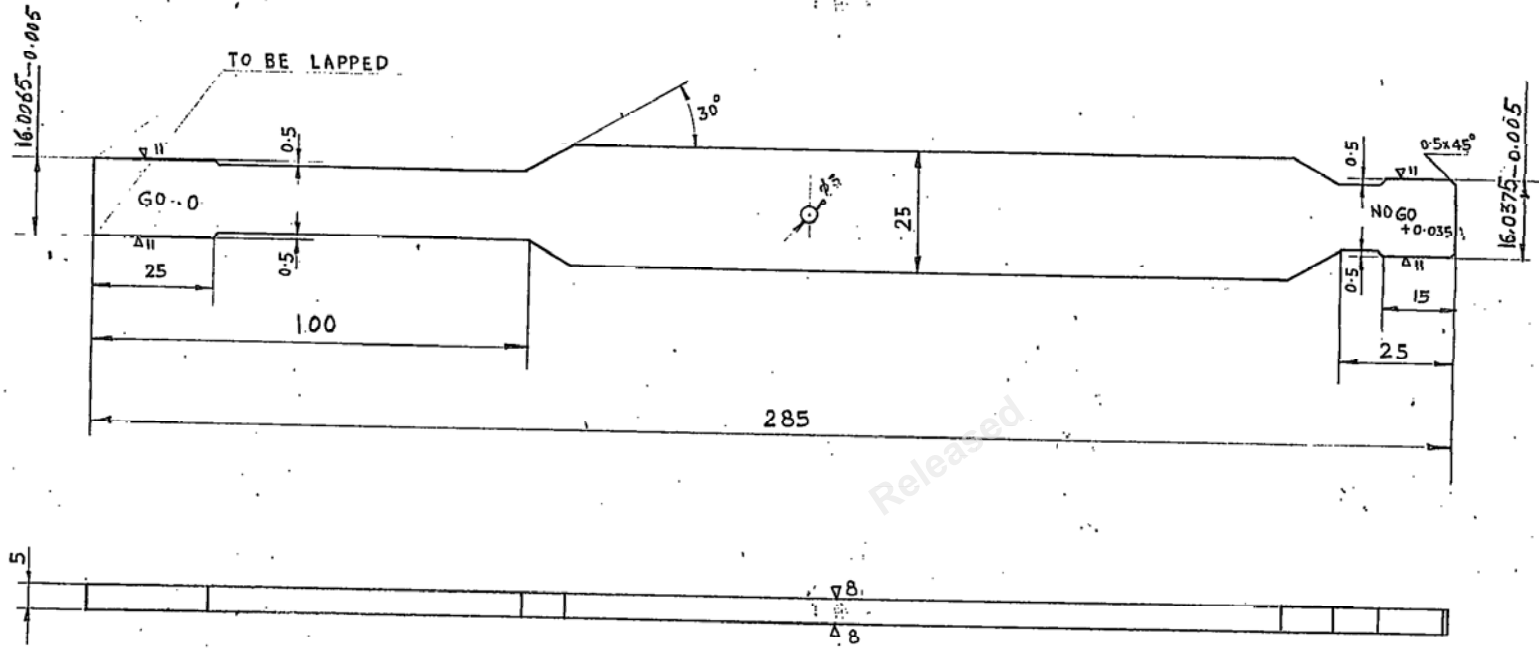

1. WORKING SURFACES TO BE CARBURISED AND HARDENED TO HRC 56-61
2. WEAR LIMIT ON GO SIDE 15.996
3. SHARP EDGES TO BE ROUNDED OFF TO R0.5

PROFILE DRG. NO. 32311028

MARK
R8141-0136
16A3
GO.0 NO GO+0.035

01		50-60		01		T90Mn6WCr2 HW10892	
SL NO	DRG NO.	DESCRIPTION	MATERIAL	NO OFF	PER PC WEIGHT	TOTAL WEIGHT	REMARK
			ST42 ST				
C-200-130							
PLATE GAUGE							
16 A3							
02	01	JTE-15-F0009	SJTERS	19.1.15			
CPD	DES.	DOCUMENT NO.	SIGN	DATE			
WORKED		SS-SAXENA					
CHECKED		S.K. GUPTA		22/1/77			
SUPERVISED		V. K. ARORA					
TECH CONTROL		T.S. MANCHANDA					
STD CONTROL		V. K. ARORA					
APPROVED		V.P. SINGH		8/7/72			
		32311000	32311004				
		ST/ 3705					
				SHEET		TOTAL SHEETS	
				JIG & TOOL			

TRACED DRAWN

SIZES 12

REVISIONS
NO. DATE BY
3-2774

Released

COPYRIGHT AND CONFIDENTIAL
 THE INFORMATION ON THIS DOCUMENT IS THE PROPERTY OF BHARAT
 HEAVY ELECTRICALS LIMITED IT MUST NOT BE USED DIRECTLY
 OR INDIRECTLY IN ANY WAY DETRIMENTAL TO THE INTEREST OF COMPANY.

FIRST ANGLE PROJECTION

(ALL DIMENSIONS ARE IN mm)

FORM DG38(B)

9610-20196

DRAWING No.

1.6
THE REST

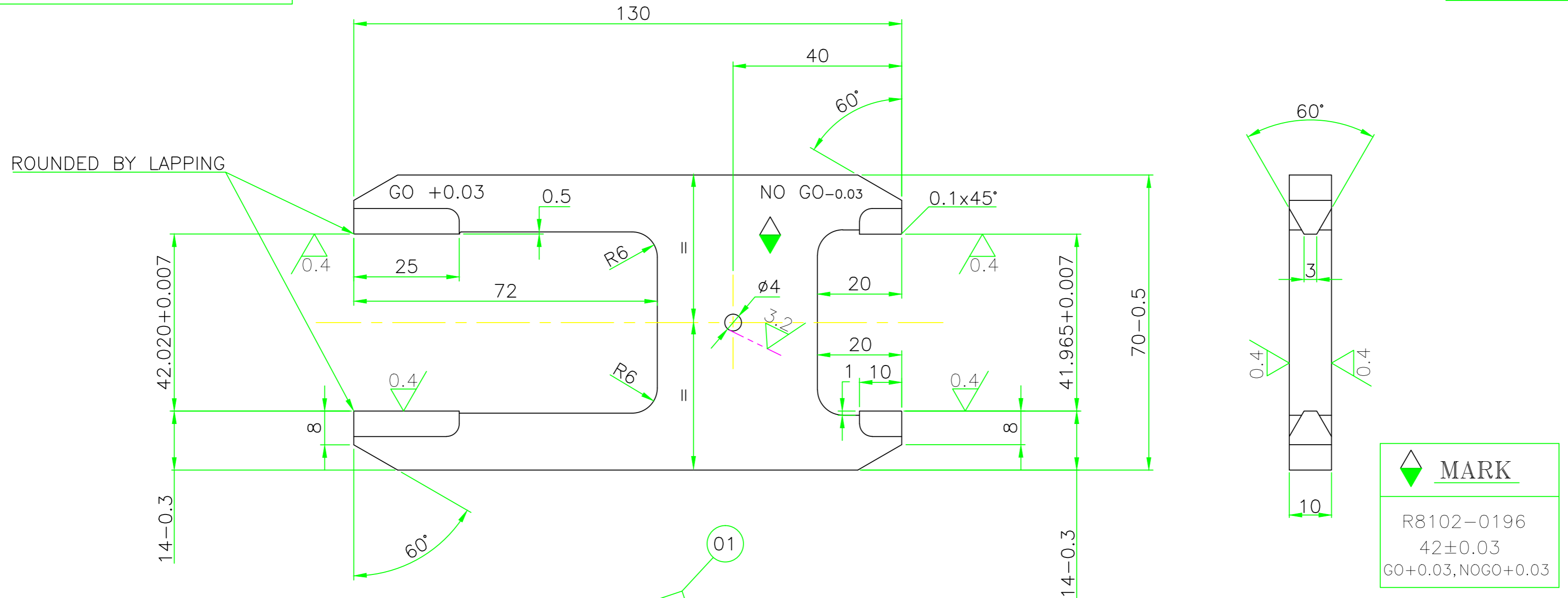

	MARK
R8102-0196	
42±0.03	
GO+0.03, NOGO+0.03	

NOTES:—

- CARBURISE & HARDEN TO HRc 50±65
- WEAR LIMIT OF GO END 42.035
- SHARP EDGES TO BE ROUNDED OFF

DRG. SUPERSEDES
 THE OLD DRG.

ITEM No.	DESCRIPTION	STD	DRAWING No.	T90Mn6WCr2	A	UNIT	UNIT WEIGHT
				HW10892	c		QTY.

3-3786 INVENTORY No. SIGN.&DATE REF. DRG. No.

GMS No./GR.SP.No.		STATUS OF DRG		TYPE OF PRODUCT		COMP. DRG. No.		M/C TOOL TRANS No.		REF. DRG. No.	
AGREED DEPT.		NAME		SIGN.		DATE		DESIGN ORDER No.		M/C MODEL No.	
SDI		MANCHANDA		-Sd-		22.09.72		ST-4016			
GRADE OF UNTOL. DIM.:—				M/CG-Ø/M/F AA0230208				WELDING-A/B/C/D AA0621104			
GAS CUTTING-'T3' AA0621101				REV				DATE			
ALTERED				REV				DATE			
CHECKED				01				31.1.15			
DRG.SUPERSEDES THE THE OLD DR. VIA C/A NO. JTE-15-F0014.				DEPT. JTE				SCALE			
				CODE 209				NTS			
TITLE				WEIGHT(Kg)				REF.TO ASSY. DRG.			
SNAP GAUGE				0.41				DRAWING No.			
42±0.03 PROFILE NO. 551								R8102-0196			
SHEET No. 01				No. OF SHEETS 01				REV.			
								SIZE A 3			

R8102-0198

FORM 01.01

✓6 THE REST

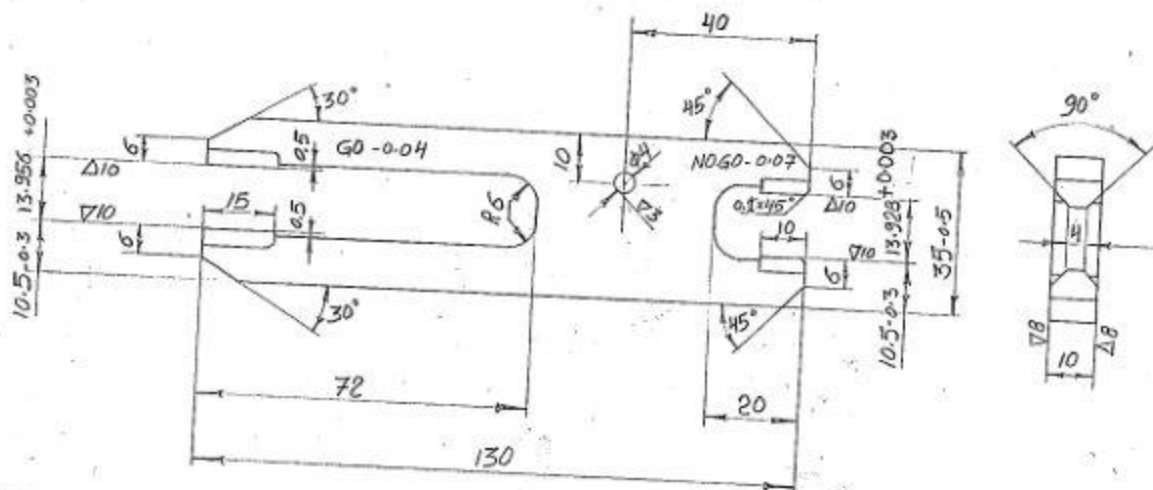

MARK
 R8102-0198
 14 ± 0.04
 GO-0.04 NOGO-0.07

- CARBURISE THE WORKING SURFACE TO A DEPTH OF 0.8-1.2 MM AND HARDEN TO HRC 50-55
- WEAR LIMIT OF GO END 13.962
- SHARP EDGES TO BE ROUNDED OFF TO R=0.5

01 T90Mn6WCr2 HW10892

ITEM No.	DESIGNATION	DESCRIPTION	PER PC	TOTAL	MAT.	REMARK
			WT. IN KG.			
		C-200-130				
01	01	JTE-15-P0017	6	22.15		
CRD	REV.	DOCUMENT NO.	SN	DATE		
DESIGNED		RAGHAVA				
CHECKED		S.K. GUPTA				
APPROVED		M.K. ARORA				
TECH CONTROL		MANCHALSA				
STD CONTROL		M.K. ARORA				
APPROVED		V.P. SINGH				
		SNAP-GAUGE				R8102-0198
		14 ± 0.04				LETTER
		PROFILE NO. 551				WEIGHT
		32304000	32304017			SCALE
		ST-4019	1			1:1
						SHEET
						TOTAL SHEETS
						TRACED DRAWN
						SIZE 12

R8141-0143

▽6 THE REST

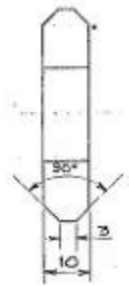
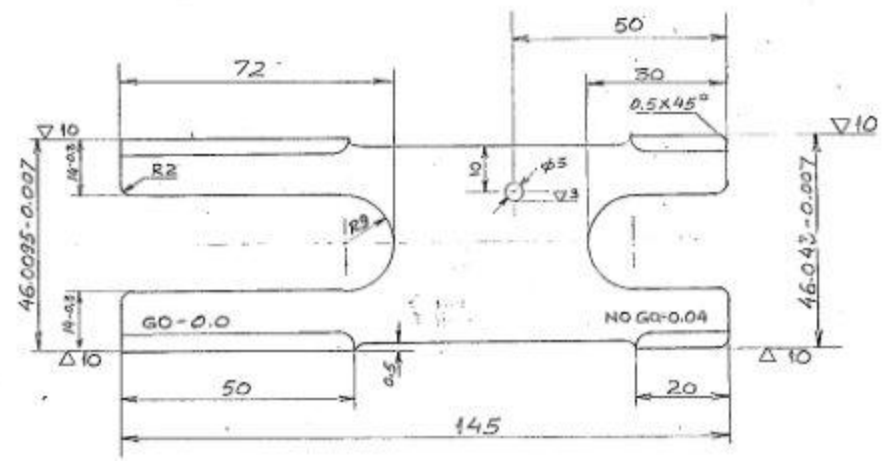

MARK
R8141-0143
46±0.04
GO 0.0 NOGO±0.04

NOTE.

1. CARBURISE TO A DEPTH OF 0.8-1.2mm AND HARDEN TO HRC 55 ± 60.
2. WEAR LIMIT ON GO SIDE: 45.995.
3. SHARP EDGES TO BE ROUNDED OFF.

① T90Mn6WCr2
HW10892

Part No.	DRG. NO.	DESCRIPTION	Qty	PR. (Total) WT.	MATERIAL	REMARKS
		C-200-130				
01	① JTE-15-F0009	SJTERS 19.1.15				R8141-0143
DESIGNER	J.K. Kapoor	DATE				LETTER WEIGHT GRAB
CHECKER	S.K. Gupta					
APPROVED	M. S. Dhillon					
TECH CONTROL	MANOJ KUMAR				328040004 32804017	SHEET TOTAL SHEETS
QTC CONTROL					ST-4013	HELP J&T
APPROVED	M.R. Gupta					SIZE 1:2

TRACED DRAWN

DRAWING NO. 71335/91
 SHOP BY, DIMENSIONS
 SUPPLEMENTARY INVENTORY NO.
 SUPERVISOR INVENTORY NO.
 SIGN AND DATE
 INVENTORY NO. 3-3709

▽6 THE BEST

R8151-0079

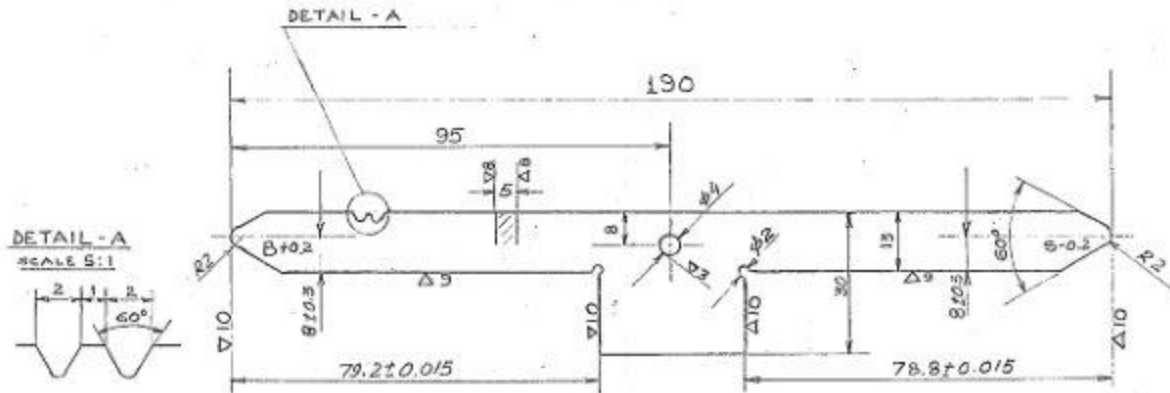

MARK
R8151-0079
79±0.2 PROFILE 55L
8±0.2 5-0.2

1. CARBURISE TO A DEPTH OF 0.8 - 1.2 mm AND HARDEN TO HRC 50-55
2. WEAR ALLOWANCE ON BOTH BIG AND SMALL SIDE ±0.025

01 T90Mn6WCr2 HW10892

DRG. NO.	DESCRIPTION	QTY	P. No.	Total WT.	MATERIAL	REMARKS
	C - 200 - 130					
	DEPTH GAUGE				R8151-0079	
	79±0.2					
	PROFILE NO. 55L					
WORKED	S. R. Kapoor					
CHECKED	S. K. Gupta					
SUPERVISOR	V. K. Anand					
TECH CONTROL	Manoharan					
STD CONTROL						
APPROVED	V. P. Singh					

TRACED DRAWN

SIZE 1:1

SHEET NO. 3-3705
 DRAWING NO. 7121042
 DATE 25.07
 SCALE 1:1
 MATERIAL T90Mn6WCr2 HW10892

COPYRIGHT AND CONFIDENTIAL
THE INFORMATION ON THIS DOCUMENT IS THE PROPERTY OF BHARAT
HEAVY ELECTRICALS LIMITED IT MUST NOT BE USED DIRECTLY
OR INDIRECTLY IN ANY WAY DETRIMENTAL TO THE INTEREST OF COMPANY.

FIRST ANGLE PROJECTION

(ALL DIMENSIONS ARE IN mm)

FORM DG38(B)

DRAWING No. R8159-0087

1.6 THE REST

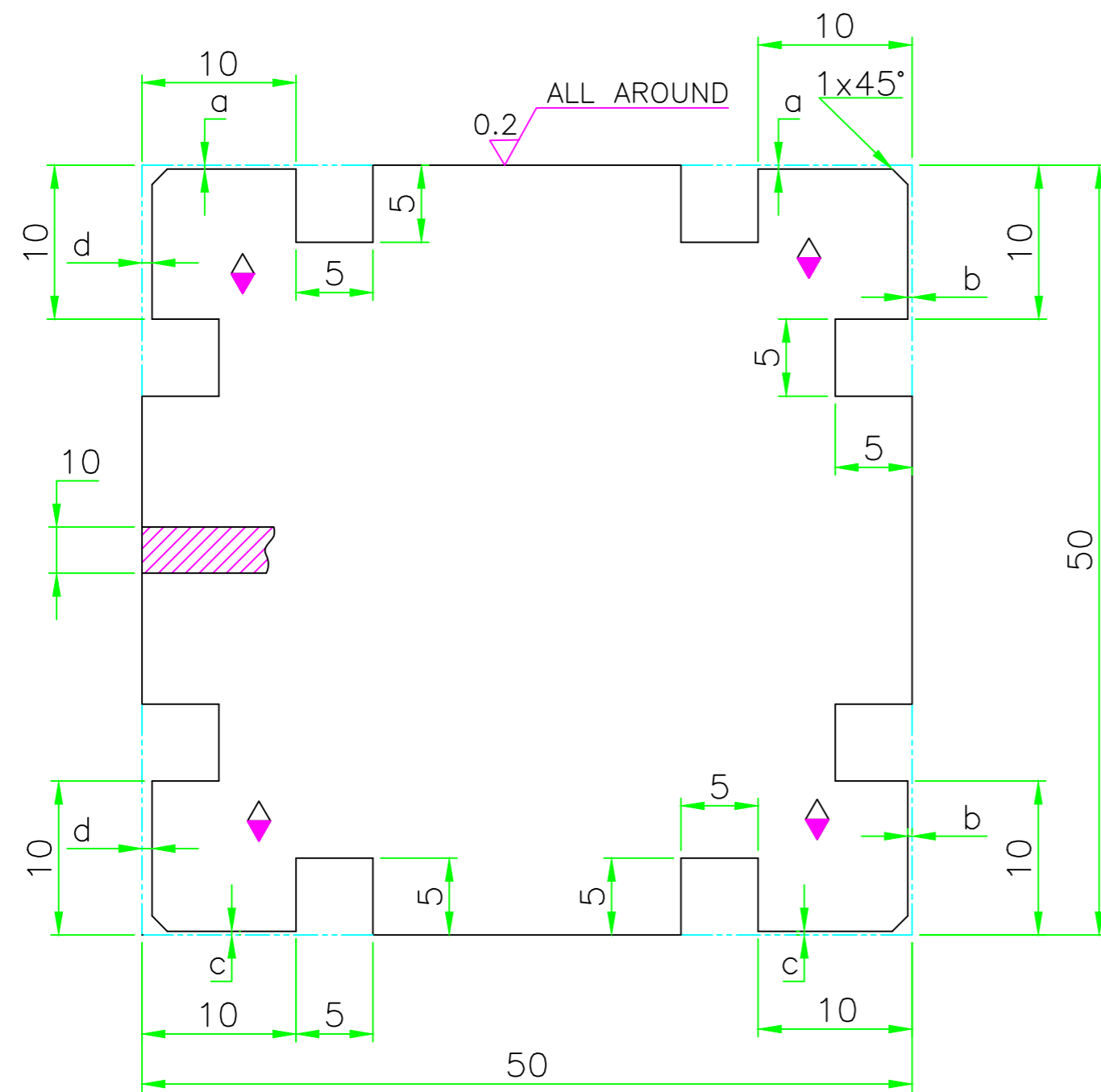

TABLE

SL. NO.	TYPE	a	b	c	d	TOLERANCE AT 20°C(±2°C)TEMPERATURE
1.	TYPE I	0.005	0.005	0.010	0.010	-0.002
2.	TYPE II	0.020	0.030	0.040	0.050	±0.005
3.	TYPE III	0.070	0.100	0.150	0.200	±0.010
4.	TYPE IV	0.015	0.025	0.035	0.045	-0.005

- HARDEN TO HRC. 60÷62 AS PER INST NO. 0912.008
- TO BE CONSERVED AS PER TL-30007.

MARK

MARK a,b,c,d AS PER TABLE ON EACH SIDE OF CORNER
DRAWING No.
TYPE OF PRODUCT

INVENTORY No.	SIGN. & DATE	REF. DRG. No.	REV	DATE	ALTERED	BY	GMS No./GR.SP.No.	STATUS OF DRG	TYPE OF PRODUCT	COMP. DRG. No.	M/C TOOL TRANS No.	REF. DRG. No.	MATERIAL CODE	UNIT	UNIT WEIGHT	QTY.															
																	VAR.	MATERIAL SPECN.													
3-12115	S.K.B	JTE/D/97/001	04	02.06.15	CHECKED	SJTESK	AA0230208		BHARAT HEAVY ELECTRICALS LTD.	8807QCX0600001			XT215Cr12	A																	
			03	03.01.97	CHECKED	V.K.C.	AA0621104		BHARAT HEAVY ELECTRICALS LTD.					AA10822	C																
			02	19.05.95	CHECKED	S.K.B	AA0621101		BHARAT HEAVY ELECTRICALS LTD.																						
			01	02.01.95	CHECKED	S.K.B			BHARAT HEAVY ELECTRICALS LTD.																						
<table border="1" style="width: 100%;"> <tr> <td>DEPT. JTE</td> <td>SCALE N.T.S</td> <td>WEIGHT(Kg) ~0.2</td> <td>REF.TO ASSY. DRG.</td> <td>ITEM No. 04</td> </tr> <tr> <td>CODE 209</td> <td></td> <td></td> <td>DRAWING No. R8159-0087</td> <td>REV. 04</td> </tr> <tr> <td colspan="3">TITLE: BURR GAUGE</td> <td>SHEET No. 01</td> <td>No. OF SHEETS 01</td> </tr> </table>																	DEPT. JTE	SCALE N.T.S	WEIGHT(Kg) ~0.2	REF.TO ASSY. DRG.	ITEM No. 04	CODE 209			DRAWING No. R8159-0087	REV. 04	TITLE: BURR GAUGE			SHEET No. 01	No. OF SHEETS 01
DEPT. JTE	SCALE N.T.S	WEIGHT(Kg) ~0.2	REF.TO ASSY. DRG.	ITEM No. 04																											
CODE 209			DRAWING No. R8159-0087	REV. 04																											
TITLE: BURR GAUGE			SHEET No. 01	No. OF SHEETS 01																											

SIZE A 3