



**BHARAT HEAVY ELECTRICALS LIMITED**  
**HEEP HARIDWAR INDIA-PIN 249403**  
**FAX NO: 0091 1334 226462**  
**PHONE NO: 0091 1334 281561**

Enq. No.: L/6454/2016/1552Y/1

M/S.....

Sub: BHEL-HEEP/OPEN-TENDER (TL)/2016

Dear Sir,

The Heavy Electricals Equipment Plant (HEEP) located in Haridwar, India is one of the major manufacturing plants of Bharat Heavy Electricals Ltd. The core business of HEEP includes design and manufacture of large steam and gas turbines, turbo generators and so on.

Sealed tenders with the Tender No. and opening date clearly super scribed on the cover are invited from the manufacturers (registered as well as unregistered) for the supply of the following items:-

Sl. No.	Tender No.	Description of Item	Qty (ST)	Opening Date
1	L/6454/2016/1552Y/1	AAA700201181 CORE PRESSING STUDS WITH NUT AND COUPLER, DRAWING NO. R7002-0118 Rev 02	1	06.08.16

The details with required delivery are given in **Annexure-1**.

The tender documents can be downloaded from our web site [www.bhel.com](http://www.bhel.com) or [www.bhelhwr.co.in](http://www.bhelhwr.co.in) or [www.tenders.gov.in](http://www.tenders.gov.in); after downloading the tender documents from web site, while submitting tender as detailed in "Instruction to Bidders" intending vendors must submit **EMD of Rs.60, 000/- by demand draft or pay order only in favor of BHEL Haridwar against this tender. Tender fees shall be nil in this tender. If EMD and/or Tender fess are not submitted then offer may be out rightly rejected.** As per notification reference no. NSIC/HO/GP/15(4)/2013-14 dated 07.07.2013 Micro & Small Enterprises (MSEs) is not required to submit tender fees and/or EMDs. A certificate in Original (duly notarized/attested by Gazetted officer) issued from competent authority shall be submitted in support of Micro & Small Enterprises (MSEs). BHEL will not be responsible for any type of postal delay / incomplete information from vendor.

**The date for opening of tender shall be 06.08.16** Tenders will be received in tender box kept at Main ADM building, HEEP – BHEL Ranipur, Haridwar – 249403, Uttarakhand (INDIA) up to **1.45 P.M. on 06.08.16** and opened on the same day at **2.00 P.M.** in the Tender Room. **Please note that tender received after due time & date (1.45PM on 06.08.16) will not be REPEAT will not be opened.** BHEL will not be responsible for any type of delay due to postal / courier etc. and it shall be the responsibility of vendor to submit offer in time in tender box. Complete Technical Specifications & Drawing cum scope of supply of the above items are available on our above mentioned website. Other cross referred Amendments/Corrigendum, if any, will be hosted on our web site only. Other terms and conditions will be as per tender documents.

**The total quantity may undergo change at the time of ordering.**

**Any vendor who is under suspension at the time of price bid opening, their price bid shall not be opened. The bids of the bidder who are on the banned list and also the bids of the bidders, who engage the services of banned firms shall be rejected. The list of firms banned by BHE is available on BHEL website [www.bhel.com](http://www.bhel.com).**

Please submit your Techno-Commercial offer only for the above requirement subject to our terms and conditions.

BIDS shall be opened at **2 PM** on the due date in the presence of authorized representative of the bidders who may like to be present. The authorized representative should bring authority letter from their parent company (Manufacturer) for the specific tender no. attending the bid opening.

BHEL will forfeit the EMD if, the successful bidder / vendor refuses to honor the order after award of the same on him and / or withdraws his bid and / or unilaterally changes the offer and / or any of its terms & conditions within the validity period.

**KINDLY READ "INSTRUCTIONS TO BIDDERS." QUOTATION NOT IN ACCORDANCE WITH THE INSTRUCTIONS ARE LIABLE TO BE DISQUALIFIED AND IGNORED.**

## INSTRUCTIONS TO BIDDERS FOR OPEN TENDER

### 1.0 DEFINITION

Registered Vendors - Are those who are registered with BHEL, Haridwar for Megawatt rating/ Size/ Weight of tendered components in respective steel grade or machining of such components.

Un-registered Vendors - Are those who are not registered with BHEL, Haridwar for Megawatt rating/ Size/ Weight of tendered components in respective steel grade or machining of such components.

### 2.0 TECHNICAL QUALIFICATION

- Enclosed format – Annexure-2 to be submitted. It is the mandatory requirement. **Offer of Vendors not meeting these requirements may not be considered.**

### 3.0 ESSENTIAL INSTRUCTIONS

1. All un-registered vendors shall be approved by BHEL, if found suitable, on the basis of data furnished by them in Supplier Registration Form (SRF) Foreign Vendors or Indigenous Vendors. Vendor (s) shall not be considered for ordering if not approved by BHEL. All un-registered bidder shall submit inter alia duly filled-in supplier registration form (SRF) along with bid. Bidders can download SRF from [www.bhel.com](http://www.bhel.com).
2. BHEL team may visit the vendor (s) works for verification of capability and capacity claimed in tender documents/offer (s).
3. The tenders shall be submitted **in two parts** as described below on or before the due date. Vendor Registration Form shall be submitted by unregistered vendors only.
  - i. **Part I (Envelop I)** – A. EMD & / or Tender Fee  
or  
Valid certificate towards exemption of tender fee & /or EMD, applicable for Micro and small Enterprises, as mentioned below:  
MSE Suppliers can avail the intended benefits only if they submit along with the offer, attested copies of either EM II certificate having deemed validity (five years from the date of issue of acknowledgement in EM II) or valid NSIC certificate or EM II certificate along with attested copy of a CA certificate (format enclosed where deemed validity of EM II certificate of five years has expired) applicable for the relevant financial year (latest audited). Date to be reckoned for determining the deemed validity will be the date of bid opening (Part 1 in case of two part bid). Non submission of such documents will lead to disqualification of their offer. Documents should be notarized or attested by a Gazetted Officer.  
  
B. Pre-Qualifying Requirement (PQR) – refer Annexure – 2.  
C. Vendor Registration Form (SRF documents to be placed separately in part-I and not to be mixed with other documents).
  - ii. Techno -Commercial Bid + Replica of Price Bid(Without prices)
  - iii. **Part II (Envelop II)** - Price Bid
4. The Quotation should be from the Principal / Original Manufacturer, failing which the quotation is likely to be ignored. However, if OEM / Principal insist on engaging the services of an agent, such agent shall not be allowed to represent more than one manufacturer / supplier in the same tender. Moreover, either the agent could bid on behalf of the manufacturer / supplier or the manufacturer / supplier could bid directly but not both. In case bids are received from both, the manufacturer / supplier and the agent, bid received from the agent shall be ignored. In Case the quotation is submitted through agent, the quotation must accompany original authorization letter from the Principal / Original Manufacturer.
5. **The bidders will have to submit ink-signed offer / bid in original directly to BHEL. Each and Every Page of offer must be duly signed and stamped. Unsigned bids shall be ignored.**
6. The suppliers or their authorized person may be allowed to attend the tender opening, if duly authorized by their principals, through a specific letter for a particular enquiry or for specific price bid opening on that particular day. General authorization letter is not acceptable
7. Any corrections / amendments shall be properly & fully authenticated with signature.
8. Compliance of technical/ commercial terms and conditions as per Annexure-3
9. Part-I will be opened on the date and time specified in the tender notice in the presence of those vendors who wish to attend.

10. Part-II (Price Bids) along with supplementary price bids, if necessary, will be opened at a later date of only those bidders who successfully qualify the PQR requirements, their techno commercial bid has been found acceptable and have submitted tender fees or valid certificate towards exemption of tender fee, applicable for Micro and small Enterprises.
11. Vendor to quote best possible deliveries in the offer. Offers of those vendors may not be considered if it is not found suitable to BHEL requirement.
12. Currency exchange rate will be applicable on the date of opening of Part-I for evaluation purpose.
13. Depending upon the delivery suitability, BHEL reserves the right to split order on more than one vendor.
14. Evaluation of Bid: - The bid shall be evaluated
  - a. Cost to BHEL basis. ( Basic Cost + Insurance + Transportation + Duty )
  - b. The loading, if any, on account of LD penalty, payment terms or any other cost determined at later stage, which shall be communicated to the vendor.
15. Tenders when finalized shall be in the name of the bidder only and change of name during tender evaluation (without certificate from registrar of company) and after submission of the tender is liable to make the offer ineligible for participation.
16. All test certificates / Guarantee certificates to be submitted in TRIPLICATE along with dispatch documents.
17. Excise duty extra as applicable at the time of supply. Vendor to do the needful as per cenvat rules so that bhel could avail cenvat credit in time.
18. Third party inspection required as per drawing. Inspection to be ensured by vendor by coordinating with bhel haridwar (Tool Room) / BHEL nominated agency. For submission of online request for third party inspection by BHEL nominated agency vendor may visit BHEL corporate website <http://cqr.bhel.in>.
19. Total weight -- /Gross / Net in Kg. & also package size essentially should be indicated if not exact then approximate.
20. BHEL will evaluate the technical bids against essential criteria/requirements. BHEL may seek clarifications, if required, from the qualified bidders only. These clarifications will be communicated to the eligible vendors. The offers of those bidders, who are unable to respond in specified time frame, are likely to be ignored.
21. MSE Suppliers can avail the intended benefits only if they submit along with the offer, attested copies of either EM II certificate having deemed validity (five years from the date of issue of acknowledgement in EM II) or valid NSIC certificate or EM II certificate along with attested copy of a CA certificate (Format enclosed at annexure-1 where deemed validity of EM II certificate of five years has expired) applicable for the relevant financial year (latest audited). Date to be reckoned for determining the deemed validity will be the date of bid opening (Part 1 in case of two part bid). Non submission of such documents will lead to consideration of their bid at par with other bidders. No benefit shall be applicable for this enquiry if any deficiency in the above required documents is found or the requisite documents are not submitted before price bid opening. If the tender is to be submitted through e-procurement portal, then the above require document are to be uploaded on the portal. Documents should be notarized or attested by a Gazette officer.
22. Any new supplier will be eligible for registration with BHEL as MSE supplier provided at least any one of the following documents (originally attested) are submitted along with application for registration :-
  - a. Valid NSIC Certificate or
  - b. Entrepreneurs Memorandum part II (EM II) certificate (valid based on deemed validity of 5 years) or
  - c. EM II certificate along with attested copy of CA Certificate (as per prescribed format at annexure 1 ) applicable for the relevant financial year (latest audited), where the deemed validity of EM II is over.However, credentials of all MSE supplier will be verified before advancing the intended benefits.
23. In case techno-commercial accepted vendors include MSE source and their prices (based on landed cost to BHEL) are within the price band of 15% w.r.t. L-1 vendor, then BHEL can offer 20% of quantity of respective item (rounded off to nearest number) to MSE vendors at L-1

price and in case, more than one MSE vendor is in 15 % band and the same is accepted by more than one MSE vendors then 20% quantities of respective Items will be considered for ordering on proportionate basis amongst MSE vendors.

24. While distributing the 20% quantity amongst MSE vendors the decimal points in quantity shall be ignored for all the vendors except the L-1 amongst MSE vendors. Balance quantity after allocating the quantity to other MSE vendors ignoring the quantities in decimal, shall be given to L-1 (amongst MSE) vendor. However if there are more than one MSE vendor at the same price level than preference for additional quantities due to ignoring off the decimal (as mentioned above) shall be given to the vendor offering favorable terms to BHEL and if the conditions offered are also same then preference will be given to the vendor having high SPR rating.
25. In case there are more than one MSE vendors (with different landed cost to BHEL) within 15% price band of lowest bidder and quantity to be offered is 1 no. only, then preference shall be given to the MSE vendor with lowest landed cost.
26. In case there are more than one MSE vendors (with same landed cost to BHEL) within 15% price band of lowest bidder and quantity to be offered is 1 no. only, then preference shall be given first, based on the favorable terms in the bid and in case terms are also same, the vendor with high SPR rating shall be given preference.
27. If L1 vendor is MSE vendor, entire quantity will be given to such MSE vendor only.

28. **Splitting to MSE vendor is not applicable for this tender**

29. SETTLEMENT OF DISPUTES

- Indigenous Vendors: In all cases of dispute the matter shall be referred for arbitration to any arbitrator to be appointed by the Executive Director or any officer who is the administrative head of Bharat Heavy Electricals Ltd., at Haridwar. The venue of arbitration shall invariably be Ranipur Haridwar. The award of the arbitrator shall be final and binding on both the parties. The arbitrator shall have the power to extend, from time to time, the time for making his award with the consent of the parties.
- Foreign Vendors: In the event of any dispute or difference arising between the parties to this contract regarding execution of same or their respective rights and liabilities there under, the same shall except as otherwise expressly provided therein, be referred to the arbitration of the two arbitrators, one to be appointed by each party; or in the case of the said arbitrators not agreeing then an umpire to be appointed by the two arbitrators in writing before entering on that reference and provisions of the Indian Arbitration Act ,1940 or any statutory notification, or re-enactment therefore and rules framed there under from time to time shall apply to such arbitration . If the two arbitrators do not agree on the appointment of umpire, the nomination of the umpire shall be done by the International Chamber of Commerce, Paris(France).The decision of arbitrators, or in case of their not agreeing, that of the said umpire shall be binding both on seller and purchaser. The venue of the arbitration invariably be New Delhi.

30. JURISDICTION

All question, dispute or differences arising under, out of or in connection with the purchase order shall be subject to the exclusive jurisdiction of Haridwar courts.

31. OVER RIDING CLAUSE

All stipulations made in any correspondence other than those exchanged in regards to “instruction” in our tender documents / enquiry for submission of your offer, if at all shall be void to the extent they are repugnant to the conditions contained herein above and in the purchase order.

32. FINALITY OF MANAGEMENT DECISION

At all places in the preceding clauses BHEL Management’s decision shall be final.

#### **4.0 GENERAL INSTRUCTIONS**

**PART-I (EMD &/or Tender fees (or exemption certificate), PQR, SRF in envelope-I)** shall comprise of following documents:

- a. Tender fees/EMD or exemption certificate (to be provided in separate envelope).
- b. ***Annexure-2 for Pre-qualification requirement. Point wise reply to all the points mentioned in Pre- Qualifying Requirement specified in the tender. Relevant documents as requested in Pre-Qualifying Requirement must be attached.***
- c. **Vendor Registration Form (SRF)**  
(Kindly follow the link and follow instructions: <http://supplier.bhel.in/>)  
The SRF duly filled up will be assessed for manufacturing capability quality systems being followed, organizational soundness and financial worthiness. The same shall be submitted with Part-I by un-registered vendor only with BHEL, HEPP, Haridwar or the proof of submission through online portal. BHEL registered vendors (registered with permanent code M, N, S) need not to submit SRF.  
For vendors registered with T code, SRF is to be submitted essentially along with the offer.
- d. Non-disclosure agreement as per Annexure 6. The agreement shall be duly stamped & signed.
- e. Complete technical offer.
- f. Annexure-3 for compliance of technical/ commercial terms and conditions.
- g. Complete technical offer as per specification, drawings, technical requirement along with un-priced bid indicating CIF rate, separate Lloyd's/BV/TUV inspection charges (for Foreign vendors) and delivery schedule
- h. Validity of offer to be indicated.
- i. Deviation with reference to specification/drawing, if any, should be clearly indicated on a separate sheet.
- j. Copy of price Bid (without prices).
- k. Any additional documents duly signed and stamped.

#### **PART –II (Price Bid)**

- a. Price bid with prices to be submitted as part-II of the tender.
- b. If price bid is not submitted along with Part-I bid, the offer will be rejected outrightly.
- c. In case of foreign vendors, prices to be quoted on CIF basis separately. In case of CIF, Loading port must be mentioned. However, for air shipment the rates to be quoted on CPT destination port basis. And air freight charges to be indicated separately in price bid. Further non-availability of flight will not be accepted for rescheduling the delivery or waiver of penalties on account of delayed delivery.
- d. In case of Indigenous vendor, prices must be quoted on **FOR-Destination-CPS-HEPP-BHEL basis**. However, the insurance will be arranged by BHEL. Vendor can dispatch good through any Indian Bank Association approved transporters having their branch at Haridwar / destination. For the convenience name and address of transporters approved by IBA and BHEL are posted at website [www.bhelhwr.co.in](http://www.bhelhwr.co.in). Further, non-availability of BHEL approved transporter will not be accepted for rescheduling of delivery or waiver of penalties.
- e. In case of foreign vendors, third party (Lloyd's/BV/TUV) inspection charges to be quoted separately as third party inspection (Lloyd's/BV/TUV) is in vendor's scope. For Indian vendors, inspection shall be by TUV/ BHEL nominated inspection agency. Prices shall be loaded by 0.18% on account of TUV/ BHEL nominated inspection agency inspection charges. Third Party inspection shall be in BHEL scope.
- f. Prices should remain firm till the execution of the order.
- g. Insurance during transportation shall be taken care of by BHEL.
- h. Applicable sales Tax, Excise duty, service tax, educational cess and any other statutory levy should be indicated separately and clearly in the quotation.
- i. **Prices are to be written in both Figures & Words. In case of any difference between the two, if there is a discrepancy between words and figures, the amount in words shall prevail for evaluation and establishing L1 status.**
- j. **Date of delivery will be considered as per the delivery terms mentioned in the Purchase order. Penalty will be applicable on total order value at the rate of ½% (half percent) per week or part thereof subject to a maximum of 10% of the PO value unless otherwise specified. Acceptance / non acceptance of this condition must be specifically mentioned in your offer. Any deviation from this will be loaded accordingly i.e BHEL shall load maximum penalty under penalty for late delivery clause, to the extent the same is not agreed by the bidder, for purpose of evaluation.**
- k. Payment term preferably shall be "100% after receipt and acceptance of material at BHEL Hardwar". **BHEL as a rule do not agree to release advance payment.**

- l. Irrevocable LC is opened for one quarter (3 months) & is established 30 days prior to delivery schedule. The charges of establishing the LC are on either side i.e. charges in India to be borne by BHEL and charges outside of India to be borne by vendor. If any vendor insists for LC for more than one quarter, vendor has to essentially bear all charges (Within & outside India) for the period exceeding one quarter.
- m. **BHEL does not open confirmed LC even if vendor agrees to bear the confirmation charges.**
- n. **The comparison between foreign and indigenous bids shall be done based on the Total Landed cost at Destination basis.**
- o. **EMD given by all unsuccessful tenderers shall be refunded on acceptance of award/LOI/PO by successful Tenderer. The EMD of successful bidder shall be returned after PO execution.**

**Note:**

After tender opening (Part-I), if it is found that:

- The bidder has not submitted the requisite Tender Fee and EMD (If applicable)
  - The bidder has claimed to be an MSE vendor but no supporting documents have been submitted in this regard.
- In both the above cases the offer of the bidder shall be straightaway rejected and no correspondence from the bidder in this regard shall be entertained.

However, offer of the bidder shall be treated as per the guideline in case the bidder has claimed to be an MSE vendor and submitted requisite MSE documents.

BHEL reserves the rights to place order for tendered quantity on more than one vendor

**Superscription on envelopes:**

The following shall be super scribed on the envelopes:

**PART-I**

1. TENDER NO. AND ITEMS DESCRIPTION
2. DUE DATE FOR OPENING.
3. TENDER FEE, EMD (IF APPLICABLE) OR MSE CERTIFICATE TOWARDS EXEMPTION OF EMD & TENDER FEE
4. PRE- QUALIFYING REQUIREMENT (PQR)
5. SUPPLIER REGISTRATION FORM (SRF)
6. NON DISCLOSURE AGREEMENT (NDA)
7. TECHNO-COMMERCIAL BID

**PART- II**

1. TENDER NO. AND ITEMS DESCRIPTION
2. DUE DATE FOR OPENING OF PART-I
3. PRICE BID

The part-I & part-II shall be individually sealed and super scribed as indicated above and shall be enclosed further in the envelop duly sealed and super scribed as:

“TENDER FOR (ITEM NAME) AGAINST TENDER NO.----- DUE ON ----- CONTAINING PART-I,PART-II & PART-III OF THIS OFFER.” Vendor’s full name and address should be clearly mentioned on the envelope and shall be addressed to:

To,

Head of Materials Management,  
Heavy Electrical Equipment Plant,  
BHEL,  
Hardwar- 249403

Envelopes not marked as above are liable to be ignored and will not be opened.

**IN CASE YOU ARE NOT MAKING AN OFFER AGAINST THIS ENQUIRY, THEN PLEASE ARRANGE TO SEND A LETTER OF REGRET IF YOU HAVE COLLECTED THE TENDER DOCUMENTS FROM BHEL.**

**Annexure- 1**

<b>Sl. No.</b>	<b>Tender No.</b>	<b>Description of Item</b>	<b>Delivery Required</b>	<b>Qty (ST)</b>
1	L/6454/2016/1552Y/1	<b>AAA700201181</b> CORE PRESSING STUDS WITH NUT & COUPLER DRG.NO. -R7002-0118 REV. -02	30.10.2016	1

- *Vendor should quote best possible delivery dates.*
- *Early delivery is also acceptable.*

**Against vendor's replies, BHEL reserves the right to ask for more information/ documents/ clarifications. Vendor's offer shall not be considered if vendor fails to furnish the document / information / clarifications as mentioned above or doesn't meet the acceptance criteria.**

Annexure – 2

**Special Instructions:**

1. Drawing R7002-0118 REV. -02 and Pre-Qualification Requirement (PQR) for item are enclosed. Vendor to give point wise reply to each and every point of & PQR and offer accordingly.
2. PO.No. &/Or vendors emblem/seal shall be clearly punched marked on each item.
3. Guarantee certificate is required & period of its validity will be at least on year from date of final acceptance of material at BHEL Haridwar.
4. PARTY TO CONFIRM SUPPLY AS PER TR/QP/66 ENCLOSED.
5. ONLY TESTED QUALITY MATERIAL TO BE STRICTLY USED AND NO DEVIATION/CONCESSION IS ALLOWED.
6. Party to confirm compliance of all notes of drawing no.R7002-0118 Rev 02.

**Against vendor's replies, BHEL reserves the right to ask for more information/ documents/ clarifications. Vendor's offer shall not be considered if vendor fails to furnish the document / information / clarifications as mentioned above or doesn't meet the acceptance criteria.**

**INDENT NO.20161552**

01.00	PRE QUALIFYING CONDITIONS	REQUIRED	OFFERED
01.01	Only those vendors to quote who have manufacturing set up to manufacture components like studs of length 2000 mm or more to quote.	Vendor to confirm	
01.02	Vendor should have supplied studs of length 2000 mm or more on their own or through their sub-supplier/manufacturing tie ups. Details of studs (dia, length, threaded length etc.) and customer details to whom these studs have been supplied with month/year of supply to be mentioned.	Vendor to submit details	
01.03	Vendor should have capability to supply studs of length 6000 mm (refer item no.10 of drawing R7002-0118 Rev.01, L=6000 mm & dia = 100 mm ). In support of this, vendor to submit details/documents to establish capability.	Vendor to submit details	
01.04	BHEL reserves the right to verify the information provided by vendor and BHEL may also visit vendor's works for verification. In case the information provided by vendor is found to be false/ incorrect, their offers are liable to be rejected.	Vendor to accept/agree	

*Pradyot*  
18/6/16

*Abant*  
18/6/16

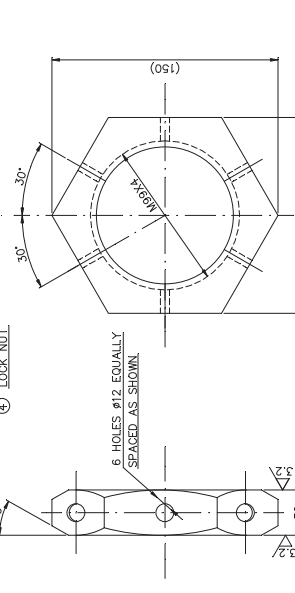
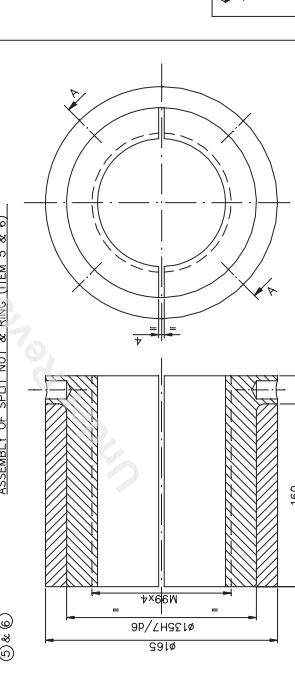
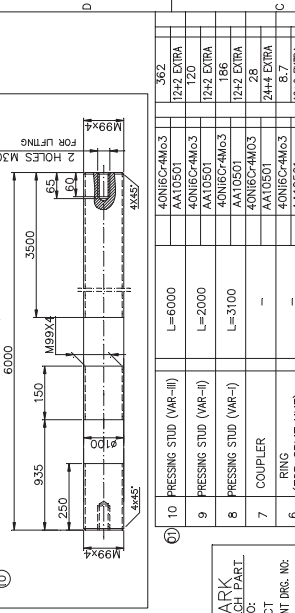
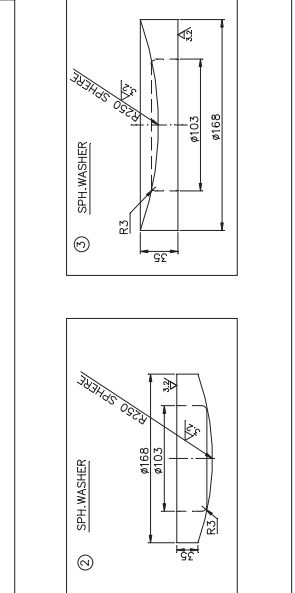
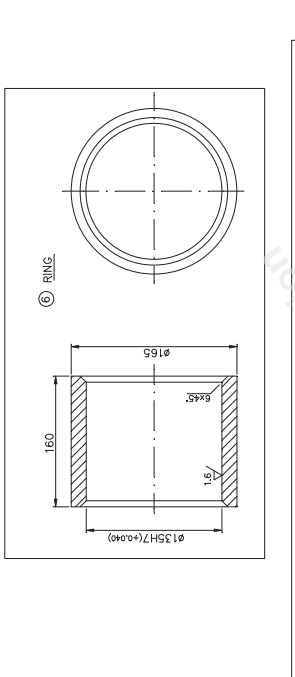
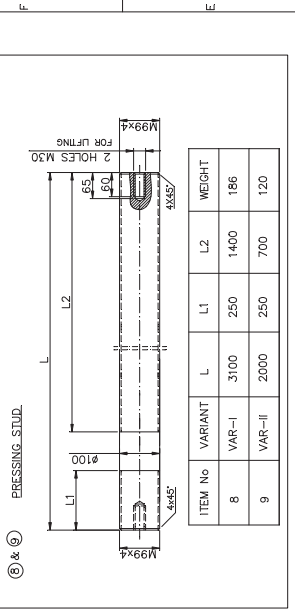
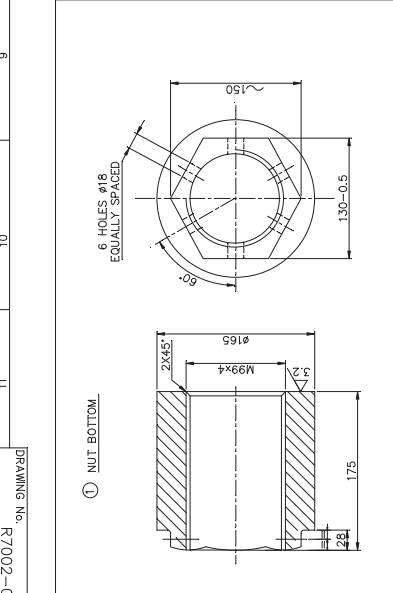
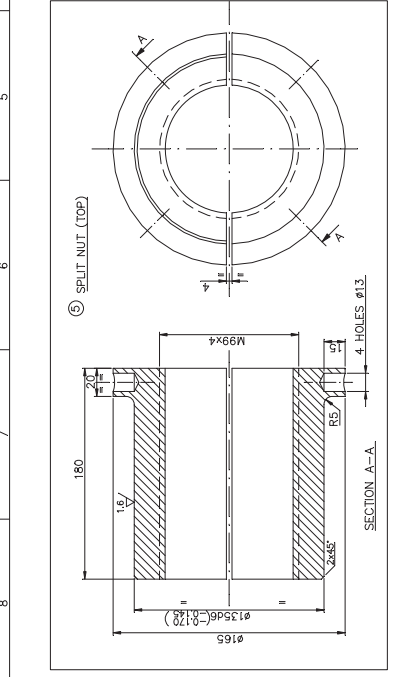
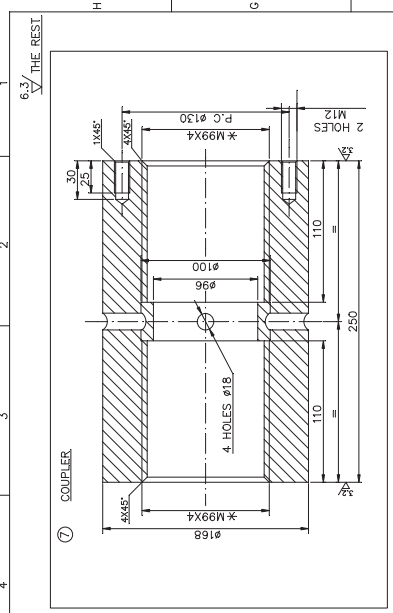

ITEM No	VARIANT	L	L1	L2	WEIGHT
8	VAR-I	3100	250	1400	186
9	VAR-II	2000	250	700	120

ITEM No.	DESCRIPTION	DRAWING No.	VAR. MATERIAL SPEC.
10	PRESSING STUD (VAR-III)	6000	
9	PRESSING STUD (VAR-I)	L=2000	
8	PRESSING STUD (VAR-I)	L=3100	
7	COUPLER		
6	RING (FOR SPLIT NUT)		
5	SPLIT NUT (TOP)		
4	LOCK NUT		
3	SPH WASHER (168x35)		
2	SPH WASHER (168x35)		
1	NUT BOTTOM (M99x4)		

MARK ON EACH PART DRG. NO. PRODUCT COMPONENT DRG. NO.

IN CASE OF MANUFACTURING OUTSIDE FROM BHEL  
 1. COMPLETE SET OF ALL ITEMS OF R7002-0118 SHOULD BE ORDERED TO ONE VENDOR FOR PROPER MATCHING/ASSLY OF THE ITEMS.  
 2. COMPLETE ASSLY OF THE ITEMS ARE AS PER SCHEME R7709-0381, IS TO BE ENSURED BY VENDOR.  
 3. IT MUST BE ENSURED THAT ALL THE ITEMS (LIKE NUT, COUPLER & STUDS) ARE INTERCHANGEABLE TO EACH OTHER.

- NOTES:-
1. ALL SHARP EDGES TO BE ROUNDED OFF.
  2. TO BE CONSERVED AS PER TL-3000Z.
  3. TO BE AGREEED ONLY AFTER TRIAL.
  4. ONLY TESTED QUALITY MATERIAL TO BE STRICTLY USED AND NO DEVIATION/CONCESSION IS ALLOWED. TEST CERTIFICATES SHOWING CHEMICAL ANALYSIS, MECHANICAL & ULTRASONIC TEST SHOULD BE SUPPLIED.
  5. MATERIAL OF ALL THE ITEMS SHALL BE TESTED ULTRASONICALLY IN ACCORDANCE WITH BHEL STANDARD AA0850118 TO ENSURE FREEDOM FROM INTERNAL DEFECTS & NORMS OF ACCEPTANCE SHALL BE AS PER CATEGORY 2.
  6. ALL THE ITEMS SHALL ALSO BE D.P. TESTED IN ACCORDANCE WITH BHEL STANDARD HW0850190.
  7. TO ENSURE FREEDOM FROM INTERNAL DEFECTS & NORMS OF ACCEPTANCE SHALL BE AS PER CATEGORY 2.
  8. THREADS (M99X4) ARE TO BE MADE SEPARATELY IN EACH SIDE. IN NO CASE BOTH THREADS ARE TO BE MADE FROM ONE END SIDE.
  9. SPLIT LOCK NUT (R7002-0127) & SPLIT COUPLER (R7002-0728) MAY BE USED DURING CORE ASSLY.

STATUS	TYPE OF PRODUCT	COMP. DRG. No.	REF. DRG. No.
OPNS	THDP-125/67	01350401108	R7002-0069
DESIGN ORDER No.	THDP-125/67/062		R7002-0110

GRADE OF UNTOLODM.	WELDING	WELDING	WELDING
M/CG-2/M/F AA0230208	WELDING-50	WELDING-50	WELDING-50
EXT. NEEPAJ KR.-50-16.614	EXT. NEEPAJ KR.-50-16.614	EXT. NEEPAJ KR.-50-16.614	EXT. NEEPAJ KR.-50-16.614

REV. DATE	ALTERED	BY	REASON
01/08/16	NOTE 3 DELETED AS PER C/A NO. JTE-14-F0118		

INVENTORY No.	REF. DRG. No.	DATE





**MANUFACTURING QUALITY PLAN**

ITEM : CORE PRESSING STUD WITH NUT & COUPLER Q.P NO : **00** TR / QP / 66  
 DRG. NO : R7002-0118 Rev 01 REV : **00** DATE **18/06/2016** PACKAGE : **TOOLINGS**  
 PAGE **2 of 2** INDENT No.: **L/6454/16/1552/Y** CONTRACTOR : **BHEL HARIDWAR**

SL NO	COMPONENTS & OPERATIONS	CHARACTERISTICS	CLASS	TYPE OF CHECK	QUANTUM OF CHECK	REFERENCE DOCUMENT	ACCEPTANCE OF NORMS	FORMAT OF RECORDS	AGENCY		REMARKS
									M	C	
1	2	3	4	5	6	7	8	9	D*	10	11
3	ASSEMBLY	1) Interchangeability of threads to be ensured. 2) Use Lubricant on spherical seats of Item no 2 & 3	Critical	Visual	100%	BHEL Drawing	BHEL Drawing	Dimension Report	P	V	
4	FINAL INSPECTION	Dimensions	Critical	Measurement	100%	BHEL Drawing	BHEL Drawing	Dimension Report	P	V	
			Major	Visual	100%	Drawing	Drawing	Internal Report	P	W	
			Critical	Visual	100%	BHEL Drawing	BHEL Drawing	Internal Report	P	W	
			Major	Visual	100%	-	-	Internal Report	P	V	
Packing - To be supplied in protected cover to avoid any damage or change in dim during transportation.											

**LEGEND :**  
 M= VENDOR  
 C= BHEL NOMINATED AGENCY  
 P=PERFORMED BY  
 V = VERIFIED BY  
 W= WITNESSED BY

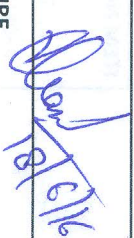
**MANUFACTURER / SUB CONTRACTOR**  
  
**APPROVED BY**  
  
**SIGNATURE**

**ANNEXURE- 3**

**COMPLIANCE SHEET FOR TECHNICAL/COMMERCIAL TERMS AND CONDITIONS FOR THREE PART TENDER**

**PLEASE FILL THIS ANNEXURE & ATTACH WITH YOUR TECHNO-COMMERCIAL BID.**

You are requested to kindly confirm /clarify the following:-

<b>S.No.</b>	<b>Description</b>	<b>Your Confirmation</b>
1.	Vendor to confirm that they meet each & every clause of our Specifications/Drawings.	
2.	If “No” to serial number 1, vendor to specify each deviated clause & submit in a separate sheet.	
3.	Vendor to list out on a separate sheet any activity which is outsourced. Please furnish details of out sourced vendor.	
4.	Validity: confirm that validity of the offer shall be 90 days from the date of tender opening	
5.	Confirm that un-priced part of price bid is enclosed with technical Commercial offer.	
6.	Confirm that prices have been quoted on CIF basis (For Foreign vendors)	
7.	Confirm that Loading Port has been mentioned.	
8.	Confirm that prices have been quoted on FOR BHEL Haridwar basis. (For Indigenous vendor)	
9.	Confirm that prices shall be firm and fixed throughout delivery period.	
10.	Payment term preferably shall be “100% after receipt and acceptance of material at BHEL Haridwar”.	
11.	LD Penalty shall be applicable on total order value at the rate of ½ % (half percent) per week or part thereof subject to a maximum of 10% of PO value. Any deviation from this will be loaded accordingly i.e BHEL shall load maximum penalty under penalty for late delivery clause, to extent the same is not agreed by bidder, for the purpose of evaluation.	
12.	Confirm that all test certificates / Guarantee certificates to be submitted as per BHEL specification. in TRIPLICATE along with dispatch documents	
13.	Right of acceptance – BHEL reserves the right to reject any or all quotations without assigning any reasons thereof. BHEL also reserves the right to increase or decrease the tendered quantities. Vendors should be prepared to accept order for reduced quantities without any extra charges. Vendor should also be prepared for giving discount in case of Increase in quantity.	
14.	Confirm specifically that material shall be supplied as per tender documents.	
15.	No grace period in delivery is acceptable. Please quote delivery accordingly.	
16.	Ink signed order acceptance shall be furnished within 15 days of order placement.	
17.	Confirm if there is Indian agency commission included in your price.	
18.	Kindly confirm ‘Testing & Certification as per ordering drawing’.	
19.	In case of PO (if any), Invoices against goods and services have to be submitted immediately after supply of goods and services but not later than 30 days from the invoice date. In case of any delay, consequential losses like loss of input credit and non-availability of concessional forms etc., shall be to the vendor’s account (For Indigenous vendor). Kindly confirm.	
20.	‘In case of delays in supplies / defective supplies or nonfulfillment of any other terms and conditions given in Purchase Order the purchaser may cancel the Purchase Order in full or part thereof, and may also make the purchase of such material from elsewhere / alternative source at the risk and cost of the supplier.’ Kindly confirm.	

ANNEXURE - 6

**NON-DISCLOSURE AND PROPRIETARY INFORMATION AGREEMENT**

BETWEEN

\_\_\_\_\_ (Name of the Vendor),, having its registered offices in \_\_\_\_\_ (Address of Vendor), registered under the no. of the Companies' register of \_\_\_\_\_ (Name of Place and Country), capital stock of \_\_\_\_\_ (Value), with a place of business in \_\_\_\_\_ (Name of Place and Country) (hereinafter referred to as " \_\_\_\_\_ (Name of Vendor)");

AND

**Bharat Heavy Electricals Ltd** a company incorporated under the Indian Companies Act 1956 having its registered offices at BHEL House, Siri Fort, New Delhi -110 049 and having one of its works at Heavy Electrical Equipment Plant, Ranipur, Haridwar-249403 ( Uttarakhand), India registered under the No. 4281 of 1964-65 of the companies register of Delhi, capital stock of Rs 4895.2 million with a place of registered office in New Delhi (hereinafter referred to as “BHEL”) hereinafter also referred to individually as “the Party” or collectively as “the Parties”.

**BACKGROUND**

This Agreement sets forth the rights and obligations of the Parties with respect to the use, handling, protection and safeguarding of Proprietary Information that is disclosed by and between the Parties.

**WHEREAS**

A) the Parties wish to pursue exploratory discussions concerning a possible collaboration between them in relation to the Program defined in Exhibit 1;

B) during the ensuing discussions and negotiations it may occur that either Party discloses to the other technical, financial or business information of a proprietary or confidential nature, which the Parties intend to protect against, making it available, by any means to any third person, and other unauthorized use and/or further disclosure by the recipient, in accordance with the terms and conditions set forth herein;

**NOW, THEREFORE**, the Parties have agreed as follows:

1. The term “Proprietary Information” shall mean any information or data of whatsoever kind of a confidential or proprietary nature, including but not limited to, commercial information, know how and technical information in the form of designs, drawings, concepts, requirements, specifications, software, interfaces, components, processes, or the like, that have been or will be disclosed by either Party to the other pursuant to this Agreement, either in writing, orally or other form, which is designated as “Proprietary” or “Confidential” by the disclosing Party by means of formal declaration or an appropriate stamp, legend or any other written or orally notice .
  
2. Proprietary Information may be conveyed, without limitation, through any written or printed documents, samples, models, electronic form on disk, tape, other storage media or any other means of disclosing such Proprietary Information that either Party may elect to use during the life of this Agreement, but if an originating Party originally discloses information orally or visually, the receiving Party will protect such information as Proprietary Information to the extent that the originating Party :
  - identifies the Information as Proprietary at the time of original disclosure,
  - summarizes the Proprietary Information in writing .

Information stored in electronic form on disk, tape, other storage media will be adequately marked if a proprietary legend displays when the information originally runs on a computer system and when the information is printed from its data file.

Proprietary Information also includes any information which can be obtained by examination, testing or analysis of any hardware or material substance or any component part of such hardware or material substance provided by the Disclosing Party even though the requirements in Clause 1 for marking and designation have not been fulfilled.

3. Each Party, to the extent of its rights to do so, shall disclose to the other only the Proprietary Information which the disclosing Party deems appropriate to fulfil the objectives of this Agreement. The Parties hereby represent that the disclosure of Proprietary Information by and between themselves shall be made in compliance with, and subject to the laws and regulations of the Disclosing Party's country.
  
4. The receiving Party hereby agrees and covenants that, from the effective date of this Agreement until the expiry date as per article 11 and the following period as per article 12, the Proprietary Information that either Party receives from the other shall:
  - a) be protected and kept in strict confidence by the receiving Party which must use the same degree of care it uses to protect its own confidential information and in no case less than a reasonable care;
  
  - b) be only disclosed to and used by those persons within the receiving Party's organization or that of its parent or controlled companies who have a need to know and solely for the purposes specified in this Agreement, and be treated by such persons or entities with the same degree of care and subject to the same restrictions;
  
  - c) to procure that each third party to whom Proprietary Information is disclosed under this Agreement is made aware of the provisions of this Agreement prior to such disclosure to it and that each such third party is

bound by obligations of confidentiality which are no less onerous than those contained in this Agreement;

- d) neither be disclosed nor caused to be disclosed or made available, either directly or indirectly, to any third Party or persons other than those mentioned in subparagraph b) above or other persons upon which both of the contractual Parties shall agree in an amendment to this Agreement;
- e) not to copy, reproduce or reduce to writing any part of such Proprietary Information except as may be reasonably necessary for the purpose referred to in the Recitals of this Agreement

PROVIDED THAT the Receiving Party shall be entitled to make any disclosure required by court order or government or regulatory requirement of the Disclosing Party's Proprietary Information subject to notifying the Disclosing Party as soon as possible of such requirement

- 5. Any Proprietary Information and copies thereof disclosed by either Party to the other shall remain the property of the disclosing Party and shall be immediately returned or destroyed by the receiving Party upon request.
- 6. The receiving Party shall have no obligations or restrictions with respect to any Proprietary Information for which the receiving Party can prove that:
  - a) is in or which comes into the public domain otherwise than as a result of a breach of this Agreement by any person to whom a disclosure of Proprietary Information is made as permitted under this Agreement or of any other duty of confidentiality relating to the Proprietary Information of which the Receiving Party has knowledge; or
  - b) it has been in its possession without restriction at the time of the disclosure, as evidenced by written documentation in its files; or
  - c) it has been lawfully received from a third Party without breach of this Agreement; or

- d) it has been or is published without violation of this Agreement; or
  - e) it has been independently developed in good faith by employees of the receiving Party who did not have access to the Proprietary Information; or
  - f) it has not been properly declared, designated or confirmed as Proprietary or Confidential; or
  - g) the protection period has expired according to articles 11 and 12 of this Agreement.
7. With respect to any exchange of Proprietary Information which may occur as a result of this Agreement, it is expressly understood and agreed that the persons listed in Exhibit 2 shall, on behalf of the respective Parties, be the exclusive individuals authorized to receive from and transmit to the other Party Proprietary Information under this Agreement. Each Party may replace at any time its respective authorized individuals identified in such Exhibit 2, within its own organization. Any such new designation by a Party shall be made by written notice to the other at the address indicated in such Exhibit 2.
8. Any Proprietary Information which is identified as “Classified Information”, or whose export is subject to an export license, shall be identified as such by the disclosing Party at the time of disclosure and the disclosure, protection, use and handling thereof, shall remain subject to the security procedures and restrictions imposed by the disclosing Party's Government.
9. The disclosure of Proprietary Information under this Agreement by either Party to the other shall not be construed as granting to the receiving Party any right, whether express or implied by licence or otherwise, on the matters, inventions or discoveries to which such information pertains, or as granting any trademark, patents, copyrights, trade secret right or other form of intellectual property right.

10. Nothing in this Agreement may be construed as an obligation of either Party to disclose any Proprietary Information to the other, or to enter into any subsequent contractual relationship with such other Party.
11. This Agreement covers the exchange of Proprietary Information which may be made by either Party to the other until ten years from signing of the agreement or any extension thereto which may be agreed upon by the Parties in writing. Proprietary information relevant to the Program detailed in Exhibit 1, already made available to the other contractual Party before the effective date, shall also be protected under this Agreement.

It is understood by the parties that, prior to disclosure, the Disclosing Party shall have obtained any government authorisation needed for the export of the Proprietary Information

12. The expiry of the period contemplated in Article 11 of this Agreement shall not relieve the receiving Party from complying with the obligations imposed by Article 4 here above with respect to the use and protection of the Proprietary Information, received prior the date of such expiry, for a period of ten (10) years after such expiry.
13. The Parties are independent contractors. Each will bear all costs and expenses in connection with this Agreement. This Agreement is intended to facilitate only the exchange of Proprietary Information and is not intended to be, and shall not be construed to create a teaming agreement, joint venture, association, partnership, or other business organisation or agency arrangement and no Party shall have the authority to bind the other without the other Party's separate prior written agreement .
14. This Agreement shall be governed by and shall be interpreted in accordance with the substantive federal laws of Switzerland excluding it's choice of law rules.

Irrespective of the foregoing each Party shall remain bound by the provisions of its own national laws and regulations with respect to the transfer or use of Classified Information or information whose export is subject to an export license.

15. All disputes among the Parties, in connection with or arising out of the existence, validity, construction, performance and termination of this Agreement (or any terms thereof), which the Parties are unable to resolve among themselves, shall be finally settled by an Arbitration. The Arbitration shall be held in Geneva (CH) in English language, in accordance with the rules of the ICC – International Chamber of Commerce by three arbitrators appointed in accordance with said rules.
16. The foregoing constitutes the entire Agreement among the Parties with respect to the subject matter hereof and supersedes and cancels all prior representations, negotiations, commitments, undertakings, communications, either oral or written, acceptances, understandings and agreements among the Parties with respect to or in connection with any of the matters to which such Agreement applies or refers.
17. Notices to \_\_\_\_\_ (**Name of Vendor**) shall be made at the following address:

**(Complete Address of Vendor)**

Attention: Mr. \_\_\_\_\_ (**Name of the Authorised Person of Vendor**)

Notices to BHEL shall be made at the following address:

BHARAT HEAVY ELECTRICALS LIMITED,

HEAVY ELECTRICAL EQUIPMENT PLANT,

Ranipur, Haridwar-249403 (Uttarakhand), India

Attention: Shri B.M.Bansal, General Manager- Materials Management

18. The effective date of this Agreement shall be the date of the last signature appearing herein.

**IN WITNESS WHEREOF**, each of the Parties has caused this Agreement, to be executed by its duly authorized officer.

Date :

Signed for and on behalf of

Signed for and on behalf of

**(Name of Vendor)**

BHEL

By:

By:

Title:

Title:

Signature:

Signature:

**EXHIBIT 1**

to the

**NON-DISCLOSURE AGREEMENT**

between

\_\_\_\_\_ **(Name of Vendor)**

and

**BHARAT HEAVY ELECTRICALS LIMITED**

dated:

\_\_\_\_\_

The Non Disclosure Agreement covers the exchange of Proprietary Information which may occur during the discussions and negotiations in view of a possible cooperation between the Parties in the following programs:

-Description of Material or Services for which the order is placed

\_\_\_\_\_ **(Name of Vendor)** list of products that require an exchange of Proprietary Information which may be occur during the discussions and negotiations in view of a possible cooperation for the above programs :