



BHARAT HEAVY ELECTRICALS LIMITED
HEEP HARIDWAR INDIA-PIN 249403
FAX NO: 0091 1334 226462
PHONE NO: 0091 1334 281561

Enq. No.: **T/6410/2016/2380D/1**

Date of issue : 05.08.2016

M/S.....

Sub: BHEL-HEEP/OPEN-TENDER (COMPONENT)/2016

Dear Sir,

The Heavy Electricals Equipment Plant (HEEP) located in Haridwar, India is one of the major manufacturing plants of Bharat Heavy Electricals Ltd. The core business of HEEP includes design and manufacture of large steam and gas turbines, turbo generators and so on.

Sealed tenders with the Tender No. and opening date clearly super scribed on the cover are invited from the manufacturers (registered as well as unregistered) for the supply of the following items:-

Sl. No.	Tender No.	Description of Item	Qty (No)	Opening Date
1	T/6410/2016/2380D/1	HW7799911581 ANGULAR MILLING HEAD FOR SKODA H.BORER (W250HC) AS PER TECHNICAL SPECIFICATION: STT0095	2	12.09.2016

The details with required delivery are given in **Annexure-1**.

The tender documents can be downloaded from our web site www.bhel.com or www.bhelhwr.co.in or www.tenders.gov.in; after downloading the tender documents from web site, while submitting tender as detailed in "Instruction to Bidders" intending vendors must submit **EMD of Rs.1, 00,000/- by demand draft or pay order only in favor of BHEL Haridwar against this tender. Tender fees shall be nil in this tender. If EMD and/or Tender fess are not submitted then offer may be out rightly rejected.** As per notification reference no. NSIC/HO/GP/15(4)/2013-14 dated 07.07.2013 Micro & Small Enterprises (MSEs) is not required to submit tender fees and/or EMDs. A certificate in Original (duly notarized/attested by Gazetted officer) issued from competent authority shall be submitted in support of Micro & Small Enterprises (MSEs). BHEL will not be responsible for any type of postal delay / incomplete information from vendor.

HEEP BHEL PMD TT003 approved vendors having vendor code M28180 & M85008 are exempted for submission of EMD.

The date for opening of tender shall be 12.09.2016. Tenders will be received in tender box kept at Main ADM building, HEEP – BHEL Ranipur, Haridwar – 249403, Uttarakhand (INDIA) up to **1.45 P.M. on 12.09.2016** and opened on the same day at **2.00 P.M.** in the Tender Room. **Please note that tender received after due time & date (1.45PM on 12.09.2016) will not be REPEAT will not be opened.** BHEL will not be responsible for any type of delay due to postal / courier etc. and it shall be the responsibility of vendor to submit offer in time in tender box.

Complete Technical Specifications & Drawing cum scope of supply of the above items are available on our above mentioned website. Other cross referred Amendments/Corrigendum, if any, will be hosted on our web site only. Other terms and conditions will be as per tender documents.

The total quantity may undergo change at the time of ordering.

Any vendor who is under suspension at the time of price bid opening, their price bid shall not be opened. The bids of the bidder who are on the banned list and also the bids of the

bidders, who engage the services of banned firms shall be rejected. The list of firms banned by BHE is available on BHEL website www.bhel.com.

Please submit your Techno-Commercial offer only for the above requirement subject to our terms and conditions.

BIDS shall be opened at **2 PM** on the due date in the presence of authorized representative of the bidders who may like to be present. The authorized representative should bring authority letter from their parent company (Manufacturer) for the specific tender no. attending the bid opening.

BHEL will forfeit the EMD if, the successful bidder / vendor refuses to honor the order after award of the same on him and / or withdraws his bid and / or unilaterally changes the offer and / or any of its terms & conditions within the validity period.

KINDLY READ "INSTRUCTIONS TO BIDDERS." QUOTATION NOT IN ACCORDANCE WITH THE INSTRUCTIONS ARE LIABLE TO BE DISQUALIFIED AND IGNORED.

INSTRUCTIONS TO BIDDERS FOR OPEN TENDER

1.0 DEFINITION

Registered Vendors - Are those who are registered with BHEL, Haridwar for Megawatt rating/ Size/ Weight of tendered components in respective steel grade or machining of such components.

Un-registered Vendors - Are those who are not registered with BHEL, Haridwar for Megawatt rating/ Size/ Weight of tendered components in respective steel grade or machining of such components.

2.0 TECHNICAL QUALIFICATION

- Enclosed format – Annexure-2 to be submitted. It is the mandatory requirement. **Offer of Vendors not meeting these requirements may not be considered.**

3.0 ESSENTIAL INSTRUCTIONS

1. All un-registered vendors shall be approved by BHEL, if found suitable, on the basis of data furnished by them in Supplier Registration Form (SRF) Foreign Vendors or Indigenous Vendors. Vendor (s) shall not be considered for ordering if not approved by BHEL. All un-registered bidder shall submit inter alia duly filled-in supplier registration form (SRF) along with bid. Bidders can download SRF from www.bhel.com.
2. BHEL team may visit the vendor (s) works for verification of capability and capacity claimed in tender documents/offer (s).
3. The tenders shall be submitted **in three parts** as described below on or before the due date. Vendor Registration Form shall be submitted by unregistered vendors only.
 - i. **Part I (Envelop I)** – A. EMD & / or Tender Fee
or
Valid certificate towards exemption of tender fee & /or EMD, applicable for Micro and small Enterprises, as mentioned below:
MSE Suppliers can avail the intended benefits only if they submit along with the offer, attested copies of either EM II certificate having deemed validity (five years from the date of issue of acknowledgement in EM II) or valid NSIC certificate or EM II certificate along with attested copy of a CA certificate (format enclosed where deemed validity of EM II certificate of five years has expired) applicable for the relevant financial year (latest audited). Date to be reckoned for determining the deemed validity will be the date of bid opening (Part 1 in case of two part bid). Non submission of such documents will lead to disqualification of their offer. Documents should be notarized or attested by a Gazetted Officer.

B. Pre-Qualifying Requirement (PQR) – refer Annexure – 2.
C. Vendor Registration Form (SRF documents to be placed separately in part-I and not to be mixed with other documents).
 - ii. **Part II(Envelope II)**-Techno -Commercial Bid + Replica of Price Bid(Without prices)
 - iii. **Part III (Envelop III)** - Price Bid
4. The Quotation should be from the Principal / Original Manufacturer, failing which the quotation is likely to be ignored. However, if OEM / Principal insist on engaging the services of an agent, such agent shall not be allowed to represent more than one manufacturer / supplier in the same tender. Moreover, either the agent could bid on behalf of the manufacturer / supplier or the manufacturer / supplier could bid directly but not both. In case bids are received from both, the manufacturer / supplier and the agent, bid received from the agent shall be ignored. In Case the quotation is submitted through agent, the quotation must accompany original authorization letter from the Principal / Original Manufacturer.
5. **The bidders will have to submit ink-signed offer / bid in original directly to BHEL. Each and Every Page of offer must be duly signed and stamped. Unsigned bids shall be ignored.**
6. The suppliers or their authorized person may be allowed to attend the tender opening, if duly authorized by their principals, through a specific letter for a particular enquiry or for specific price bid opening on that particular day. General authorization letter is not acceptable
7. Any corrections / amendments shall be properly & fully authenticated with signature. No overwriting is acceptable.

8. Compliance of technical/ commercial terms and conditions as per Annexure-3
9. Part-I will be opened on the date and time specified in the tender notice in the presence of those vendors who wish to attend.
10. Part-II bid will be opened of the vendors who successfully qualify the PQR requirements and have submitted Tender Fees &/or EMD or valid certificate towards exemption of EMD & Tender fees, Applicable for Micro and Small Enterprises.
11. Part-III (Price Bids) along with supplementary price bids, if necessary, will be opened at a later date of only those bidders who successfully qualify the PQR requirements, their techno commercial bid has been found acceptable and have submitted tender fees or valid certificate towards exemption of tender fee, applicable for Micro and small Enterprises.
12. Vendor to quote best possible deliveries in the offer. Offers of those vendors may not be considered if it is not found suitable to BHEL requirement.
13. Currency exchange rate will be applicable on the date of opening of Part-I for evaluation purpose.
14. Depending upon the delivery suitability, BHEL reserves the right to split order on more than one vendor.
15. Evaluation of Bid: - The bid shall be evaluated
 - a. Cost to BHEL basis. (Basic Cost + Insurance + Transportation + Duty)
 - b. The loading, if any, on account of LD penalty, payment terms or any other cost determined at later stage, which shall be communicated to the vendor.
16. Tenders when finalized shall be in the name of the bidder only and change of name during tender evaluation (without certificate from registrar of company) and after submission of the tender is liable to make the offer ineligible for participation.
17. All test certificates / Guarantee certificates to be submitted in TRIPLICATE along with dispatch documents.
18. BHEL reserves the right to open the price bid (part-III) along with the opening of techno-commercial offer (Part-II) at its option and in that case vendor will be informed accordingly.
19. BHEL reserves the right to go for reverse auction. Vendors are requested to give their best price. In case of failure of reverse auction the paper bid shall be processed. Bidder should clearly indicate their acceptance for reverse auctioning in Annexure-3. The bids of those vendors who do not agree for reverse auction may not be considered. The Terms & Condition for Reverse Auctioning are enclosed.
20. Total weight -- /Gross / Net in Kg. & also package size essentially should be indicated if not exact then approximate.
21. BHEL will evaluate the technical bids against essential criteria/requirements. BHEL may seek clarifications, if required, from the qualified bidders only. These clarifications will be communicated to the eligible vendors. The offers of those bidders, who are unable to respond in specified time frame, are likely to be ignored.
22. The bidder shall have to pay 5% incidental charges while taking back supplied material if it is found rejected on receipt. The rejected material shall be sent back only after receipt of replacement /submission of BG/refund of amount paid.
23. Any discount/revised offer/bids submitted by a bidder on its own shall be considered, provided it is received on or before the due date and time of offer/bid submission (Part-1). Conditional discounts shall not be considered for evaluation of tenders.
24. Unsolicited discounts/revised offers/bids given after Part-1 bid opening shall not be accepted. No change in price will be permitted within the validity period asked for in the tender enquiry
BHEL reserves the right to short close the existing Purchase Order / Rate Contract / Work Order or any extension thereof at any stage.
25. **RISK PURCHASE.** In case of abnormal delays (beyond the maximum lated elivery period as per Penalty clause) in supplies / defective supplies or non-fulfillment of any other terms and conditions given in Purchase Order, BHEL may cancel the Purchase Order in full or part thereof, and may also make the purchase of such material from elsewhere / alternative source at the risk and cost of the supplier. BHEL will take all reasonable steps to get the material from alternate source at optimum cost. If bidder does not agree to the above Risk Purchase Clause, BHEL reserves the right to reject the offer. In case for compelling reasons BHEL accepts the offer without acceptance of this clause by the bidder and in the eventuality of Risk Purchase, appropriate action will be taken as per BHEL extant rules. This will be without prejudice to any other right of BHEL under the contract.
26. **WHARFAGE / DEMURRAGE RESPONSIBILITY.** In the event of delay in receipt of documents by Manager (Stores-Shipping) BHEL-Haridwar and in case where dispatches are made through Unapproved Transporter the sole responsibility for wharfage/demurrage for such delay shall be that of supplier.
27. MSE Suppliers can avail the intended benefits only if they submit along with the offer, attested copies of either EM II certificate having deemed validity (five years from the date of issue of acknowledgement in EM II) or valid NSIC certificate or EM II certificate along with attested copy of a CA certificate (Format enclosed at annexure-1 where deemed validity of EM II certificate of five years has expired) applicable for the relevant financial year (latest audited). Date to be reckoned for determining the deemed validity will be the date of bid opening (Part 1 in case of two part bid). Non

submission of such documents will lead to consideration of their bid at par with other bidders. No benefit shall be applicable for this enquiry if any deficiency in the above required documents is found or the requisite documents are not submitted before price bid opening. If the tender is to be submitted through e-procurement portal, then the above required documents are to be uploaded on the portal. Documents should be notarized or attested by a Gazette officer.

28. Any new supplier will be eligible for registration with BHEL as MSE supplier provided at least any one of the following documents are submitted along with application for registration :-
 - a. Valid NSIC Certificate or b. Entrepreneurs Memorandum part II (EM II) certificate (valid based on deemed validity of 5 years) or c. EM II certificate along with attested copy of CA Certificate (as per prescribed format at annexure 1) applicable for the relevant financial year (latest audited), where the deemed validity of EM II is over. However, credentials of all MSE supplier will be verified before advancing the intended benefits.
29. MSE vendors claiming SC/ST status will have to submit SC/ST certificate of the Proprietor from competent authority. Attested (notarized or attested by Gazetted officer) copy to be submitted along with the offer.
30. In case techno-commercial accepted vendors include MSE source and their prices (based on landed cost to BHEL) are within the price band of 15% w.r.t. L-1 vendor, then BHEL can offer 20% of quantity of respective item (rounded off to nearest number) to MSE vendors at L-1 price and in case, more than one MSE vendor is in 15 % band and the same is accepted by more than one MSE vendors then 20% quantities of respective Items will be considered for ordering on proportionate basis amongst MSE vendors.
31. While distributing the 20% quantity amongst MSE vendors the decimal points in quantity shall be ignored for all the vendors except the L-1 amongst MSE vendors. Balance quantity after allocating the quantity to other MSE vendors ignoring the quantities in decimal, shall be given to L-1 (amongst MSE) vendor. However if there are more than one MSE vendor at the same price level than preference for additional quantities due to ignoring off the decimal (as mentioned above) shall be given to the vendor offering favorable terms to BHEL and if the conditions offered are also same then preference will be given to the vendor having high SPR rating.
32. In case there are more than one MSE vendors (with different landed cost to BHEL) within 15% price band of lowest bidder and quantity to be offered is 1 no. only, then preference shall be given to the MSE vendor with lowest landed cost.
33. In case there are more than one MSE vendors (with same landed cost to BHEL) within 15% price band of lowest bidder and quantity to be offered is 1 no. only, then preference shall be given first, based on the favorable terms in the bid and in case terms are also same, the vendor with high SPR rating shall be given preference.
34. If L1 vendor is MSE vendor, entire quantity will be given to such MSE vendor only.
35. Splitting of QTY to MSE is not applicable in this tender.

36. SETTLEMENT OF DISPUTES

Indigenous Vendors: In all cases of dispute the matter shall be referred for ARBITRATION by sole arbitrator to be appointed by the Unit Head of Bharat Heavy Electricals Ltd., at HARIDWAR. The award of the Arbitrator shall be final and binding on both the parties. The place of Arbitration shall be Haridwar. **JURISDICTION:** The courts of Haridwar, India, shall have exclusive jurisdiction.

Foreign Vendors: Any dispute/difference arising out of or in connection with this contract, including any question regarding its existence, validity or termination, shall be referred to and finally resolved by arbitration under the Arbitration and Conciliation Act, 1996 of India by a Sole Arbitrator to be appointed with mutual consent of the parties. Such Sole Arbitrator shall be either a retired judge of Supreme Court or High Court or District Court of India or some Advocate having practiced in Indian Courts. The seat or place of arbitration shall be New Delhi, India. The language to be used in the arbitration shall be English. The governing law of the contract shall be the substantive law of India. In case the parties fail to agree on the appointment of arbitrator within 2 months of the notice invoking arbitration by one party, then the arbitrator shall be appointed in accordance with the Arbitration and Conciliation Act, 1996 of India.

37. JURISDICTION

All question, dispute or differences arising under, out of or in connection with the purchase order shall be subject to the exclusive jurisdiction of Court of Haridwar, India

38. OVER RIDING CLAUSE

All stipulations made in any correspondence other than those exchanged in regards to “instruction” in our tender documents / enquiry for submission of your offer, if at all shall be void to the extent they are repugnant to the conditions contained herein above and in the purchase order.

39. FINALITY OF MANAGEMENT DECISION

At all places in the preceding clauses BHEL Management’s decision shall be final.

4.0 GENERAL INSTRUCTIONS

PART-I (EMD &/or Tender fees (or exemption certificate), PQR, SRF in envelope-I) shall comprise of following documents:

- a. Tender fees/EMD or exemption certificate (to be provided in separate envelope).
- b. ***Annexure-2 for Pre-qualification requirement. Point wise reply to all the points mentioned in Pre- Qualifying Requirement specified in the tender. Relevant documents as requested in Pre-Qualifying Requirement must be attached.***
- c. **Vendor Registration Form (SRF)**
(Kindly follow the link and follow instructions: <http://supplier.bhel.in/>)
The SRF duly filled up will be assessed for manufacturing capability quality systems being followed, organizational soundness and financial worthiness. The same shall be submitted with Part-I by un-registered vendor only with BHEL, HEPP, Haridwar or the proof of submission through online portal. BHEL registered vendors (registered with permanent code M, N, S) need not to submit SRF.
For vendors registered with T code, SRF is to be submitted essentially along with the offer.
- d. Non-disclosure agreement as per Annexure 6. The agreement shall be duly stamped & signed.

PART-II (Technical Clarification in Envelope-II) shall comprises of following documents:

- a. Complete technical offer.
- b. Annexure-3 for compliance of technical/ commercial terms and conditions.
- c. Complete technical offer as per specification, drawings, technical requirement along with un-priced bid indicating CIF rate, separate Lloyd's/BV/TUV inspection charges (for Foreign vendors) and delivery schedule (***Point wise reply to each and every point of Technical specification STT0095 shall be submitted.***)
- d. Validity of offer to be indicated.
- e. Deviation with reference to specification/drawing, if any, should be clearly indicated on a separate sheet.
- f. Copy of price Bid (without prices).
- g. Any additional documents duly signed and stamped.

PART -III (Price Bid)

- a. Price bid with prices to be submitted as part-III of the tender.
- b. If price bid is not submitted along with Part-I bid, the offer will be rejected outrightly.
- c. In case of foreign vendors, prices to be quoted on CIF/FOB/FCA basis separately. In case of CIF/FOB, Loading port must be mentioned. However, for air shipment the rates to be quoted on FCA destination port basis. And air freight charges to be indicated separately in price bid. Further non-availability of flight will not be accepted for rescheduling the delivery or waiver of penalties on account of delayed delivery.
- d. In case of Indigenous vendor, prices must be quoted on **FOR-Destination-CPS-HEEP-BHEL** basis. However, the insurance will be arranged by BHEL. Vendor can dispatch good through any Indian Bank Association approved transporters having their branch at Haridwar / destination. For the convenience name and address of transporters approved by IBA and BHEL are posted at website www.bhelhwr.co.in. Further, non-availability of BHEL approved transporter will not be accepted for rescheduling of delivery or waiver of penalties.
- e. In case of foreign vendors, third party (Lloyd's/BV/TUV) inspection charges to be quoted separately as third party inspection (Lloyd's/BV/TUV) is in vendor's scope. For Indian vendors, inspection shall be by TUV/ BHEL nominated inspection agency. Prices shall be loaded by 0.20% on account of TUV/ BHEL nominated inspection agency inspection charges. Third Party inspection shall be in BHEL scope.
- f. Prices should remain firm till the execution of the order.
- g. Insurance during transportation shall be taken care of by BHEL.
- h. Applicable sales Tax, Excise duty, service tax, educational cess, TDS on import of services and any other statutory levy should be indicated separately and clearly in the quotation.
- i. **Kindly quote your prices in figures and words both. In case of any discrepancy in value, the prices quoted in words shall be considered for evaluation and establishing L1.**
- j. Prices quoted should not be more than the prices quoted to any other BHEL units/offices/divisions. Vendor to submit copy of latest Purchase Order placed by any unit of BHEL for similar items in the technical bid. In case no order has been placed on such items, specific confirmation that no order has been placed on such items should be provided.

- k. Prices should be quoted on F.O.R. Destination basis. Transit insurance shall be arranged by BHEL and not to be included in the prices. The offers quoted on other than F.O.R destination basis may result in non-consideration of such bids.
- l. For indigenous vendor: In case BHEL accepts the EX-Works prices such offers will be loaded by 1.5% of EX-Works value towards freight or with actual freight charges as per BHEL freight rate contract whichever is higher.
- m. For foreign vendor: If BHEL agrees to accept the FOB condition, to arrive at landed cost at our plant/site, the FOB prices shall be loaded for 3% (of FOB Value) towards marine insurance, port handling charges & inland freight or actual freight / port handling charges as per BHEL contract whichever is higher.
- n. **Date of delivery will be considered as per the delivery terms mentioned in the Purchase order. Penalty will be applicable on total order value at the rate of ½% (half percent) per week or part thereof subject to a maximum of 10% of the total PO value unless otherwise specified. Acceptance / non acceptance of this condition must be specifically mentioned in your offer. Any deviation from this will be loaded accordingly i.e BHEL shall load maximum penalty under penalty for late delivery clause, to the extent the same is not agreed by the bidder, for purpose of evaluation.**
- o. Payment term preferably shall be “80% payment (80% of PO Value) against dispatch documents & 20% of PO value + Erection & Commissioning charges, if any after successful completion of commissioning/prove out, through irrevocable LC (for foreign vendors) with bank charges as either side’ and “80% payment (80% Of PO Value) after receipt of material at BHEL & 20% of PO Value + Erection & Commissioning charges, if any after successful completion of commissioning/prove out (for indigenous vendors)”. **BHEL as a rule do not agree to release advance payment.**
- p. Irrevocable LC is opened for one quarter (3 months) & is established 30 days prior to delivery schedule. The charges of establishing the LC are on either side i.e. charges in India to be borne by BHEL and charges outside of India to be borne by vendor. If any vendor insists for LC for more than one quarter, vendor has to essentially bear all charges (Within & outside India) for the period exceeding one quarter.
- q. **BHEL does not open confirmed LC even if vendor agrees to bear the confirmation charges.**
- r. **The comparison between foreign and indigenous bids shall be done based on the Total Landed cost at Destination basis.**
- s. **EMD given by all unsuccessful tenderers shall be refunded on acceptance of award/LOI/PO by successful Tenderer. The EMD of successful bidder shall be returned after submission of Contract Execution Bank Guarantee(CBG)**

Note:

After tender opening (Part-I), if it is found that:

- The bidder has not submitted the requisite Tender Fee and EMD (If applicable)
 - The bidder has claimed to be an MSE vendor but no supporting documents have been submitted in this regard.
- In both the above cases the offer of the bidder shall be straightaway rejected and no correspondence from the bidder in this regard shall be entertained.

However, offer of the bidder shall be treated as per the guideline in case the bidder has claimed to be an MSE vendor and submitted requisite MSE documents.

BHEL reserves the rights to place order for tendered quantity on more than one vendor

Superscription on envelopes:

The following shall be super scribed on the envelopes:

PART-I

1. TENDER NO. AND ITEMS DESCRIPTION
2. DUE DATE FOR OPENING.
3. TENDER FEE, EMD (IF APPLICABLE) OR MSE CERTIFICATE TOWARDS EXEMPTION OF EMD & TENDER FEE
4. PRE- QUALIFYING REQUIREMENT (PQR)
5. SUPPLIER REGISTERATION FORM (SRF)
6. NON DISCLOSURE AGREEMENT (NDA)

PART-II

1. TENDER NO. AND ITEMS DESCRIPTION
2. DUE DATE FOR OPENING OF PART-I
3. TECHNO-COMMERCIAL BID

PART- III

1. TENDER NO. AND ITEMS DESCRIPTION
2. DUE DATE FOR OPENING OF PART-I
3. PRICE BID

The part-I, part-II, & part-III shall be individually sealed and super scribed as indicated above and shall be enclosed further in the envelop duly sealed and super scribed as:

“TENDER FOR (ITEM NAME) AGAINST TENDER NO.----- DUE ON -----
CONTAINING PART-I,PART-II & PART-III OF THIS OFFER.” Vendor’s full name and address should be clearly mentioned on the envelope and shall be addressed to:

To,

Head of Materials Management,
Heavy Electrical Equipment Plant,
BHEL,
Hardwar- 249403

Envelopes not marked as above are liable to be ignored and will not be opened.

**IN CASE YOU ARE NOT MAKING AN OFFER AGAINST THIS ENQUIRY, THEN PLEASE
ARRANGE TO SEND A LETTER OF REGRET IF YOU HAVE COLLECTED THE TENDER
DOCUMENTS FROM BHEL.**

TERMS AND CONDITIONS OF REVERSE AUCTIONING

Against this enquiry for the subject item /system with detailed scope of supply as per enquiry specifications, BHEL may resort to “REVERSE AUCTION PROCEDURE” i.e., ON LINE BIDDING ON INTERNET.

- For the proposed reverse auction, technically and commercially acceptable bidders only shall be eligible to participate.
- BHEL will engage the services of a service provider who will provide all necessary training and assistance before commencement of on-line bidding on internet.
- BHEL will inform the vendor in writing in case of reverse auction, the details of Service Provider to enable them to contact & get trained.
- Business rules like event date, time, start price, bid decrement, extensions etc. also will be communicated through service provider for compliance.
- Vendors have to fax the Compliance form in the prescribed format (provided by Service provider) before start of Reverse auction. Without this, the vendor will not be eligible to participate in the event.
- BHEL will provide the calculation sheet (e.g., EXCEL sheet) which will help to arrive at “Total Cost to BHEL” like Packing & forwarding charges, Taxes and Duties, Freight charges, Insurance, Service Tax for Services and loading factors (for non-compliance to BHEL standard Commercial terms & conditions) for each of the vendor to enable them to fill-in the price and keep it ready for keying in during the Auction.
- Reverse auction will be conducted on scheduled date & time.
- At the end of Reverse Auction event, the lowest bidder value will be known on the network.
- The lowest bidder has to Fax the duly signed Filled-in prescribed format as provided on case-to-case basis to BHEL through Service provider within 24 hours of Auction without fail.
- Any variation between the on-line bid value and the signed document will be considered as sabotaging the tender process and will invite disqualification of vendor to conduct business with BHEL as per prevailing procedure.
- In case BHEL decides not to go for Reverse Auction procedure for this tender enquiry, the Price bids and price impacts, if any, already submitted and available with BHEL shall be opened as per BHEL’s standard practice.

Tender Enq:T/6410/2016/2380D/1

Annexure- 1

Sl. No.	Tender No.	Description of Item	Delivery Required	Qty (No)
1	T/6410/2016/2380D/1	HW7799911581 ANGULAR MILLING HEAD FOR SKODA H.BORER (W250HC) AS PER TECHNICAL SPECIFICATION: STT0095	30.12.2016	2

- *Vendor should quote best possible delivery dates.*
- *Early delivery is also acceptable.*

Against vendor's replies, BHEL reserves the right to ask for more information/ documents/ clarifications. Vendor's offer shall not be considered if vendor fails to furnish the document / information / clarifications as mentioned above or doesn't meet the acceptance criteria.

Annexure – 2

Special Instructions:

1. Technical Specification cum Scope of Supply STT0095 and Pre-Qualification Requirement (PQR) are enclosed. Vendor to give point wise reply to each and every point of Technical Specification STT0095 & PQR and offer accordingly.
2. Guarantee & Test Certificate are required.
3. Operation and Maintenance Manual is required.
4. Recommended spares as per technical specification are required.
5. Commissioning of the Milling head shall be carried out at BHEL Works by the supplier.
6. Vendor to quote commissioning charges separately if any.
7. Warrantee certificate for minimum 12 month from date of commissioning is required.

Against vendor's replies, BHEL reserves the right to ask for more information/ documents/ clarifications. Vendor's offer shall not be considered if vendor fails to furnish the document / information / clarifications as mentioned above or doesn't meet the acceptance criteria.

PRE-QUALIFYING REQUIREMENT (PQR) FOR INDENT NO: 20162380		
Sl. No.	<u>Requirement</u>	Vendor's Response
1	Only those vendors (Original Equipment Manufactures - OEMs / Authorized suppliers of OEMs) who have supplied at least one one no. RIGH ANGULAR MILLING HEAD for Horizontal Boring machine with spindle dia 160 or more In last 10 years are only eligible to quote.	
	The vendor should submit following information regarding company where refered RIGH ANGULAR MILLING HEAD has been supplied.	
1.1	Name & Address of the customer / company.	
1.2	Date of supply of RIGH ANGULAR MILLING HEAD	
1.3	Authorized Supplier should submit copy of authorization certificate from OEMs for supply of RIGH ANGULAR MILLING HEAD and confirmation to take guarantee obligation as per specification.	
1.4	BHEL reserves the right to verify the information provided by vendor. In case the information is found to be false /incorrect, the offer shall be rejected.	

SR. MGR. (TTX)

AGM (TTX)

DILIP KUMAR
(ENGR. / TTX)

Dilip Kumar
02/05/2016

[Signature]
1/8/16

[Signature]
1.8.16

6

दिनांक / तारीख SIGN & DATE		उत्पाद क्रय विनिर्देश PRODUCT PURCHASE SPECIFICATION (TURBINE TECHNOLOGY)	STT0095 मुख्य पृष्ठ PREFACE SHEET	
सुपरीचर INVENTORY NO	ANGULAR MILLING HEAD केवल आंतरिक प्रयोग हेतु प्रदायक को देने से पूर्व इस मुख्य पृष्ठ को निकाल दें। FOR INTERNAL USE ONLY REMOVE THIS PREFACE BEFORE ISSUE TO SUPPLIERS.			
कॉपीराइट और गोपनीयता COPYRIGHT AND CONFIDENTIAL	समतुल्य मानक / सूची आदि COMPARABLE STANDARDS / CATALOGUES ETC.			
सुझाए / सम्भावित प्रदायक एवं श्रेणी SUGGESTED / PROBABLE SUPPLIERS AND GRADES.	कोई अन्य जानकारी ANY OTHER INFORMATIONS			
दिनांक / तारीख SIGN & DATE	स्वीकृति APPROVED			
दिनांक / तारीख SIGN & DATE	REV. NO. - (03) DL- 18.07.16	तैयारी PREPARED TTX	जारी ISSUED TSX	क्र. नं. 9 दिनांक DATE 18.07.16

Review and prepare: SIGN & DATE		<h2 style="margin:0;">उत्पाद क्रय विनिर्देश</h2> <h3 style="margin:0;">PRODUCT PURCHASE SPECIFICATION</h3> <h4 style="margin:0;">(TURBINE TECHNOLOGY)</h4>	STT0095 Page 1 of 5
------------------------------------	---	--	-----------------------------------

ANGULAR MILLING HEAD

1.0 PURPOSE :
ANGULAR MILLING HEAD is attached to the front face of ram of SKODA HORIZONTAL BORING machines.
- Vendor to note & confirm

2.0 FEATURE OF MACHINE FOR WHICH ANGULAR MILLING HEAD IS REQUIRED:

- 2.1. Model & serial no of machine : SKODA H BORER (W250HC, serial No Ob22075)
- 2.2. Main spindle taper : Metric 140
- 2.3. Speed ratio (Main spindle to Milling Head spindle) : 1:1
- 2.4. Spindle speeds : 1.6 – 630 RPM
- 2.5. Ram cross section : 520 mm X 520 mm
- 2.6. PCD & Hole size (For mounting of Head on RAM face) : Dia 475 mm & M20
- 2.7. Spindle diameter : 250 mm

- Vendor to note and confirm that offer head will meet all requirement as per clause no 2.0

3.0 FEATURE OF ANGULAR MILLING HEAD:
Head should be IFW2A model of SKODA make or equivalent with following parameters.

- 3.1. Taper in milling head spindle : Standard ISO 60
- 3.2. Size of the Head taper for mounting : Compatible to machine spindle taper metric 140
- 3.3. Adaptor for the Head with ISO taper 60 : MT6, MT5 & MT4 (1 Nos for each size against each head).
- 3.4. Admissible Torque : 2900 Nm or more.
- 3.5. Maximum Output : vendor to specify
- 3.6. Maximum cutter diameter : Dia 250 or more
- 3.7. Milling Head Swivels through : 0 – 360 Degree
- 3.8. Maximum admissible speed : Vendor to offer
 - A) At maximum output
 - B) At maximum torque

- Vendor offer against all above points of 3.0

4.0 OTHER REQUIREMENT:



- 4.1 The angular positioning of the Head must be indicated by graduated scale fixed on head-body (0-360° at an increment of minimum 1°) and the positioning/indexing of the Head shall be done manually at any angular degree.
- 4.2 Material: Detail of material for Gear, shaft etc to be provided by the vendor.
- 4.3 Bearing: Detail of Bearing used to be provided by the vendor.
- 4.4 Clamping Mechanism for holding tools is to be specify & provided by the vendor.
- 4.5 Tooling required for Clamping and de-clamping is to be provided by the vendor.
- 4.6 Oil/Grease: Detail of Oil/Grease used in Head to be provided by the vendor.

				नाम NAME	दिनांक एवं हस्ताक्षर SIGNATURE & DATE
PRODUCTION(TUN)	ARBIND K CHAUBEY	<i>Arbind</i> 18/7/16	अनुवाद TRANSLATED BY		
WEX MECH-MAIN	ASHOK KUMAR	<i>Ashok</i> 10/12/16	निष्पादन WORKED BY	DILIP KUMAR	<i>Dilip</i> 18/7/16
सुपरीकृत AGREED DEPTT	नाम NAME	दिनांक एवं हस्ताक्षर DATE & SIGNATURE	अनुमोदित CHECKED BY	SWAPAN SARKAR	<i>Swapan</i> 18/7/16
			पर्यवेक्षण SUPERVISED BY		
			स्वीकृत APPROVED : M. K. TOLIA	<i>M. K. Tolia</i> 18.7.16	Gr. NO. 9
REV. NO. : 00			निर्माण PREPARED : TTX	प्रति ISSUED : TSX	दिनांक DATE 18.07.16
DL : 18.07.16					
CHANGE ADVICE NO					

4

<p>संकेत एवं तारीख SIGN & DATE</p>		<p style="text-align: center;">उत्पाद क्रय विनिर्देश</p> <p style="text-align: center;">PRODUCT PURCHASE SPECIFICATION (TURBINE TECHNOLOGY)</p>	<p>STT0095</p>
<p>सुपरसिडीस INVENTORY</p>	<p>सुपरसिडीस INVENTORY</p>		<p>Page 2 of 5</p>
<p style="text-align: center;">COPYRIGHT AND CONFIDENTIAL</p> <p>The information on this document is the property of Bharat Heavy Electricals Limited. It must not be used directly or indirectly in any way detrimental to the interest of the company.</p>	<p>संकेत एवं तारीख SIGN & DATE</p>	<p>5.0 SPARE: Apart from standard spares supplied with the head following should be quoted by the party: 5.1. Matching Bevel Gears : 1 No - Vendor to confirm.</p> <p>6.0 ACCEPTANCE CRITERIA: 6.1. The Head shall be mounted on existing machine (2.1 of specification) and its complete functionality shall be demonstrated by the vendor. 6.2. Commissioning of the Milling head shall be carried out at BHEL Works by the supplier. Supplier shall demonstrate the performance of the head by carrying out Facing, Milling, Drilling, Boring and Tapping operations on a BHEL Job/test piece. Job/test piece, tooling shall be provided by BHEL. Supplier should also demonstrate mounting and unmounting of the head on the machine. 6.3. The Angular milling head should be suitable for machining Alloy steel with face milling cutter diameter 250 mm and depth of cut 8 mm. 6.4. Training of BHEL personnel in operation & maintenance of supplied angular head. 6.5. First feeling of Oil/Grease is to be done by the vendor. - Vendor to confirm all above points of 6.0</p> <p>7.0 DOCUMENTATION: 7.1. Three Hard copies of Operation and Maintenance Manual and should contain complete assembly drawing with marked of each component with their specification. 7.2. Test Certificates and Guarantee certificate is required along with the supply. 7.3. Part drawings of Head components (Gears, Worms, Worms shaft chuck nut etc) is to be provided by the vendor. 7.4. Lubrication drawings is to be provided by the vendor. 7.5. The offer should be complete having list & quantity of each item offered with item wise price, technical details & drawings etc. for clear understanding of the offer. - Vendor to confirm all above points of 7.0</p> <p>8.0 WARRANTY: Vendor shall provide a warranty for a period of 12 months from the date of Commissioning/Acceptance of the equipment.</p> <p>9.0 SPECIAL INSTRUCTION: Offer head should be in line with sketch & photo enclosed. Rest of the details will have to be recorded directly from the available Milling Head at BHEL, Haridwar. In case, vendor requires any clarification, they may discuss with BHEL or visit BHEL, Haridwar prior to submission of their offer to avoid any gaps at later stage.</p>	
			<p>सुपरसिडीस एवं गोपनीय संकेत एवं तारीख SIGN & DATE</p>
<p>सुपरसिडीस INVENTORY NO</p>	<p>REV. NO.: 00</p>	<p>निर्माणाकर्ता WORKED BY</p> <p>DILIP KUMAR</p>	<p>18.07.16</p>
<p>सुपरसिडीस INVENTORY NO</p>	<p>REV. NO.: 00</p>	<p>जांचकर्ता CHECKED BY</p> <p>SWAPAN SARKAR</p>	<p>18.07.16</p>

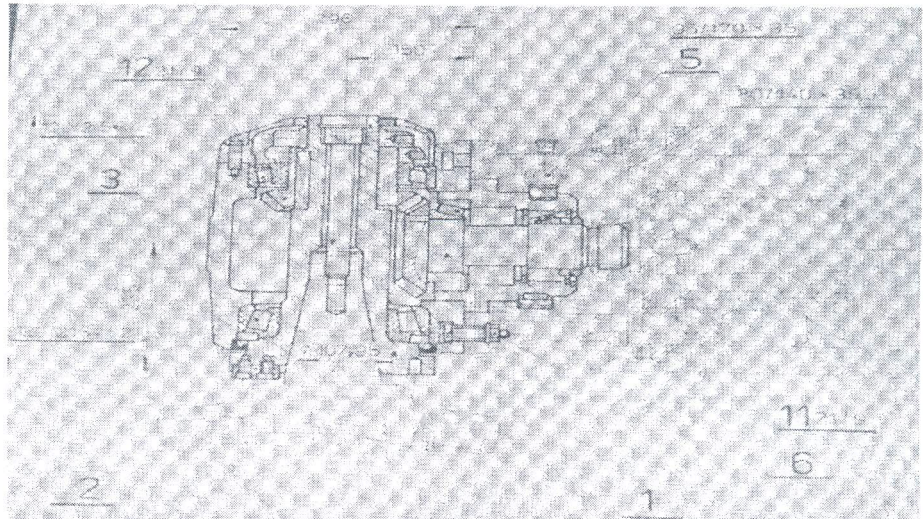
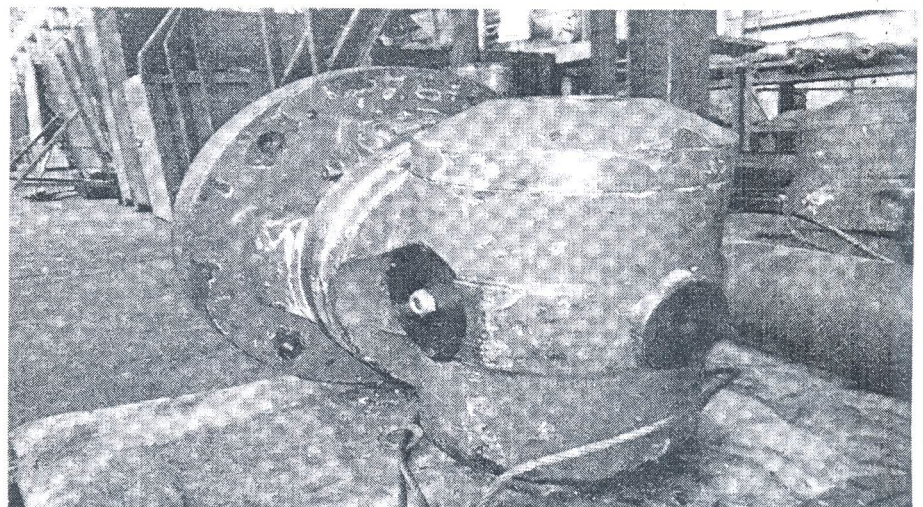





3

<p>संस्था/प्रकल्प SIGN & DATE</p>		<p>उत्पाद क्रय विनिर्देश PRODUCT PURCHASE SPECIFICATION (TURBINE TECHNOLOGY)</p>		<p>STT0095 Page 3 of 5</p>	
<p>संस्था/प्रकल्प SIGN & DATE</p>	<p>SKETCH & PHOTO OF ANGULAR MILLING HEAD</p>				
<p>संस्था/प्रकल्प SIGN & DATE</p>	<div style="text-align: center;">  </div>				
<p>संस्था/प्रकल्प SIGN & DATE</p>	<div style="text-align: center;">  </div>				
<p>संस्था/प्रकल्प SIGN & DATE</p>	<p>REV. NO.: 00</p>				
<p>संस्था/प्रकल्प SIGN & DATE</p>		<p>निर्माणकर्ता WORKED BY</p> <p>जांचकर्ता CHECKED BY</p>	<p>DILIP KUMAR</p> <p>SWAPAN SARKAR</p>	 	<p>18.07.16</p> <p>18.07.16</p>

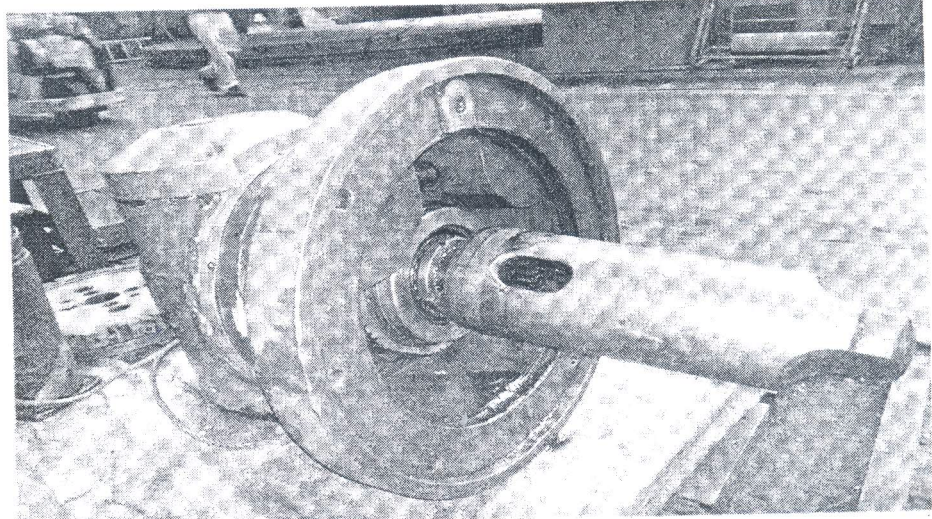
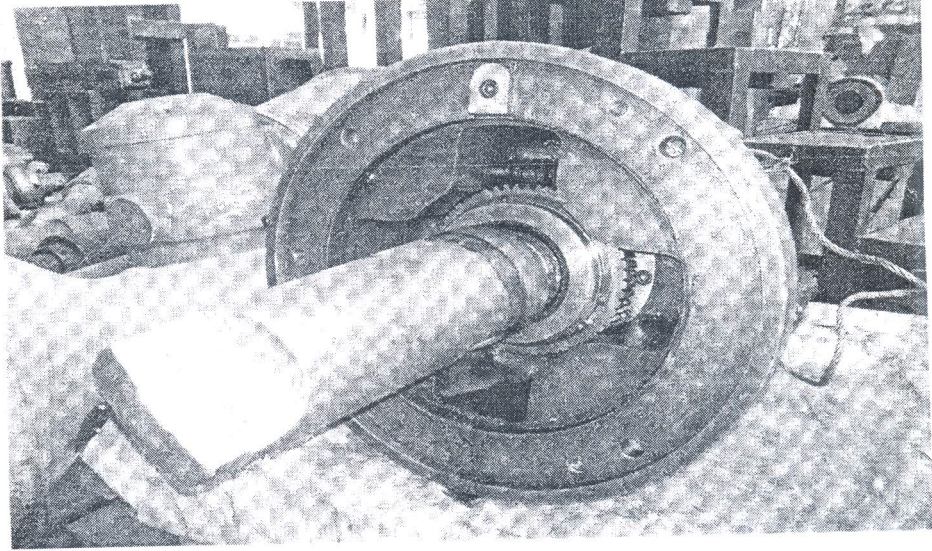
COPYRIGHT AND CONFIDENTIAL
 The information contained herein is the property of Bharat Heavy Electricals Limited. It is not to be used, directly or indirectly, in any way without the written consent of the company.

भारतीय विद्युत प्राधिकरण
 The information contained herein is the property of Bharat Heavy Electricals Limited. It is not to be used, directly or indirectly, in any way without the written consent of the company.

2

Date of Receipt SIGN & DATE		<p style="text-align: center;">उत्पाद क्रय विनिर्देश</p> <p style="text-align: center;">PRODUCT PURCHASE SPECIFICATION (TURBINE TECHNOLOGY)</p>	STT0095								
SUPERSEDES INVENTORY			Page 4 of 5								
Copyright and Confidential This information and the documents are the property of Bharat Heavy Electricals Limited and are to be used only for the purpose intended. It is to be kept confidential and its disclosure to any other person is strictly prohibited.	स्वतंत्रता एवं गोपनीयता यह सूचना और दस्तावेज़ भारत भारी विद्युत की संपत्ति हैं और केवल उद्देश्य के लिए ही उपयोग में आनी चाहिए। इसे गोपनीय और सुरक्षित रखना आवश्यक है। इसकी किसी भी अन्य व्यक्ति को देना या प्रकट करना वर्जित है।										
											
Date of Receipt SIGN & DATE											
Inventory No.	REV. NO.: 00		<table border="1"> <tr> <td>निर्माणाकर्ता WORKED BY</td> <td>DILIP KUMAR</td> <td></td> <td>18.07.16</td> </tr> <tr> <td>जांचकर्ता CHECKED BY</td> <td>SWAPAN SARKAR</td> <td></td> <td>18.07.16</td> </tr> </table>	निर्माणाकर्ता WORKED BY	DILIP KUMAR		18.07.16	जांचकर्ता CHECKED BY	SWAPAN SARKAR		18.07.16
निर्माणाकर्ता WORKED BY	DILIP KUMAR		18.07.16								
जांचकर्ता CHECKED BY	SWAPAN SARKAR		18.07.16								

ANNEXURE- 3

COMPLIANCE SHEET FOR TECHNICAL/COMMERCIAL TERMS AND CONDITIONS FOR THREE PART TENDER**PLEASE FILL THIS ANNEXURE & ATTACH WITH YOUR TECHNO-COMMERCIAL BID.**

You are requested to kindly confirm /clarify the following:-

S.No.	Description	Your Confirmation
1.	Vendor to confirm that they meet each & every clause of our Specifications/Drawings.	
2.	If "No" to serial number 1, vendor to specify each deviated clause & submit in a separate sheet.	
3.	Vendor to list out on a separate sheet any activity which is outsourced. Please furnish details of out sourced vendor.	
4.	Validity: confirm that validity of the offer shall be 90 days from the date of tender opening	
5.	Confirm that un-priced part of price bid is enclosed with technical Commercial offer.	
6.	Confirm that prices have been quoted on CIF/FOB/FCA basis (For Foreign vendors)	
7.	Confirm that Loading Port has been mentioned.	
8.	Confirm that prices have been quoted on FOR BHEL Haridwar basis. (For Indigenous vendor)	
9.	Confirm that prices shall be firm and fixed throughout delivery period.	
10.	Confirm that payment term preferably shall be "80% (of PO Value) payment against dispatch documents & 20% of PO Value + E & C charges, if any after successful completion of commissioning/prove out at BHEL Haridwar (for Indigenous vendor) and "80%(of PO value) payment after receipt of material at BHEL & 20% of PO Value + E & C charges, if any after successful completion of commissioning/prove out through irrevocable L/C (for foreign vendor) with Bank charges shall be either side.	
11.	LD Penalty shall be applicable on total order value at the rate of ½ % (half percent) per week or part thereof subject to a maximum of 10% of total PO value. Any deviation from this will be loaded accordingly i.e BHEL shall load maximum penalty under penalty for late delivery clause, to extent the same is not agreed by bidder, for the purpose of evaluation.	
12.	Confirm that all test certificates / Guarantee certificates to be submitted as per BHEL specification. in TRIPLICATE along with dispatch documents	
13.	Right of acceptance – BHEL reserves the right to reject any or all quotations without assigning any reasons thereof. BHEL also reserves the right to increase or decrease the tendered quantities. Vendors should be prepared to accept order for reduced quantities without any extra charges. Vendor should also be prepared for giving discount in case of Increase in quantity.	
14.	Confirm specifically that material shall be supplied as per tender documents.	
15.	No grace period in delivery is acceptable. Please quote delivery accordingly.	
16.	Ink signed order acceptance shall be furnished within 15 days of order placement.	
17.	Confirm if there is Indian agency commission included in your price.	
18.	Kindly confirm 'Testing & Certification as per ordering drawing'.	
19.	Please confirm your acceptance for Reverse Auctioning of these items.	
20.	In case of PO (if any), Invoices against goods and services have to be submitted immediately after supply of goods and services but not later than 30 days from the invoice date. In case of any delay, consequential losses like loss of input credit and non-availability of concessional forms etc., shall be to the vendor's account (For Indigenous vendor). Kindly confirm.	
21.	'In case of delays in supplies / defective supplies or nonfulfillment of any other terms and conditions given in Purchase Order the purchaser may cancel the Purchase Order in full or part thereof, and may also make the purchase of such material from elsewhere / alternative source at the risk and cost of the supplier.' Kindly confirm.	

ANNEXURE - 6

NON-DISCLOSURE AND PROPRIETARY INFORMATION AGREEMENT

BETWEEN

_____ (Name of the Vendor), having its registered offices in
_____ (Address of Vendor), registered under the no.
of the Companies' register of _____ (Name of Place and Country),
capital stock of _____ (Value), with a place of business in
_____ (Name of Place and Country) (hereinafter referred to as
" _____ (Name of Vendor)");

AND

Bharat Heavy Electricals Ltd a company incorporated under the Indian Companies Act 1956 having its registered offices at BHEL House, Siri Fort, New Delhi -110 049 and having one of its works at Heavy Electrical Equipment Plant, Ranipur, Haridwar-249403 (Uttarakhand), India registered under the No. 4281 of 1964-65 of the companies register of Delhi, capital stock of Rs 4895.2 million with a place of registered office in New Delhi (hereinafter referred to as "BHEL") hereinafter also referred to individually as "the Party" or collectively as "the Parties".

BACKGROUND

This Agreement sets forth the rights and obligations of the Parties with respect to the use, handling, protection and safeguarding of Proprietary Information that is disclosed by and between the Parties.

WHEREAS

A) the Parties wish to pursue exploratory discussions concerning a possible collaboration between them in relation to the Program defined in Exhibit 1;

B) during the ensuing discussions and negotiations it may occur that either Party discloses to the other technical, financial or business information of a proprietary or confidential nature, which the Parties intend to protect against, making it available, by any means to any third person, and other unauthorized use and/or further disclosure by the recipient, in accordance with the terms and conditions set forth herein;

NOW, THEREFORE, the Parties have agreed as follows:

1. The term “Proprietary Information” shall mean any information or data of whatsoever kind of a confidential or proprietary nature, including but not limited to, commercial information, know how and technical information in the form of designs, drawings, concepts, requirements, specifications, software, interfaces, components, processes, or the like, that have been or will be disclosed by either Party to the other pursuant to this Agreement, either in writing, orally or other form, which is designated as “Proprietary” or “Confidential” by the disclosing Party by means of formal declaration or an appropriate stamp, legend or any other written or orally notice .
2. Proprietary Information may be conveyed, without limitation, through any written or printed documents, samples, models, electronic form on disk, tape, other storage media or any other means of disclosing such Proprietary Information that either Party may elect to use during the life of this Agreement, but if an originating Party originally discloses information orally or visually, the receiving Party will protect such information as Proprietary Information to the extent that the originating Party :
 - identifies the Information as Proprietary at the time of original disclosure,
 - summarizes the Proprietary Information in writing .

Information stored in electronic form on disk, tape, other storage media will be adequately marked if a proprietary legend displays when the information originally runs on a computer system and when the information is printed from its data file.

Proprietary Information also includes any information which can be obtained by examination, testing or analysis of any hardware or material substance or any component part of such hardware or material substance provided by the Disclosing Party even though the requirements in Clause 1 for marking and designation have not been fulfilled.

3. Each Party, to the extent of its rights to do so, shall disclose to the other only the Proprietary Information which the disclosing Party deems appropriate to fulfil the objectives of this Agreement. The Parties hereby represent that the disclosure of Proprietary Information by and between themselves shall be made in compliance with, and subject to the laws and regulations of the Disclosing Party's country.

4. The receiving Party hereby agrees and covenants that, from the effective date of this Agreement until the expiry date as per article 11 and the following period as per article 12, the Proprietary Information that either Party receives from the other shall:
 - a) be protected and kept in strict confidence by the receiving Party which must use the same degree of care it uses to protect its own confidential information and in no case less than a reasonable care;

 - b) be only disclosed to and used by those persons within the receiving Party's organization or that of its parent or controlled companies who have a need to know and solely for the purposes specified in this Agreement, and be treated by such persons or entities with the same degree of care and subject to the same restrictions;

 - c) to procure that each third party to whom Proprietary Information is disclosed under this Agreement is made aware of the provisions of this Agreement prior to such disclosure to it and that each such third party is

bound by obligations of confidentiality which are no less onerous than those contained in this Agreement;

- d) neither be disclosed nor caused to be disclosed or made available, either directly or indirectly, to any third Party or persons other than those mentioned in subparagraph b) above or other persons upon which both of the contractual Parties shall agree in an amendment to this Agreement;
- e) not to copy, reproduce or reduce to writing any part of such Proprietary Information except as may be reasonably necessary for the purpose referred to in the Recitals of this Agreement

PROVIDED THAT the Receiving Party shall be entitled to make any disclosure required by court order or government or regulatory requirement of the Disclosing Party's Proprietary Information subject to notifying the Disclosing Party as soon as possible of such requirement

- 5. Any Proprietary Information and copies thereof disclosed by either Party to the other shall remain the property of the disclosing Party and shall be immediately returned or destroyed by the receiving Party upon request.
- 6. The receiving Party shall have no obligations or restrictions with respect to any Proprietary Information for which the receiving Party can prove that:
 - a) is in or which comes into the public domain otherwise than as a result of a breach of this Agreement by any person to whom a disclosure of Proprietary Information is made as permitted under this Agreement or of any other duty of confidentiality relating to the Proprietary Information of which the Receiving Party has knowledge; or
 - b) it has been in its possession without restriction at the time of the disclosure, as evidenced by written documentation in its files; or
 - c) it has been lawfully received from a third Party without breach of this Agreement; or

- d) it has been or is published without violation of this Agreement; or
 - e) it has been independently developed in good faith by employees of the receiving Party who did not have access to the Proprietary Information; or
 - f) it has not been properly declared, designated or confirmed as Proprietary or Confidential; or
 - g) the protection period has expired according to articles 11 and 12 of this Agreement.
7. With respect to any exchange of Proprietary Information which may occur as a result of this Agreement, it is expressly understood and agreed that the persons listed in Exhibit 2 shall, on behalf of the respective Parties, be the exclusive individuals authorized to receive from and transmit to the other Party Proprietary Information under this Agreement. Each Party may replace at any time its respective authorized individuals identified in such Exhibit 2, within its own organization. Any such new designation by a Party shall be made by written notice to the other at the address indicated in such Exhibit 2.
8. Any Proprietary Information which is identified as “Classified Information”, or whose export is subject to an export license, shall be identified as such by the disclosing Party at the time of disclosure and the disclosure, protection, use and handling thereof, shall remain subject to the security procedures and restrictions imposed by the disclosing Party's Government.
9. The disclosure of Proprietary Information under this Agreement by either Party to the other shall not be construed as granting to the receiving Party any right, whether express or implied by licence or otherwise, on the matters, inventions or discoveries to which such information pertains, or as granting any trademark, patents, copyrights, trade secret right or other form of intellectual property right.

10. Nothing in this Agreement may be construed as an obligation of either Party to disclose any Proprietary Information to the other, or to enter into any subsequent contractual relationship with such other Party.
11. This Agreement covers the exchange of Proprietary Information which may be made by either Party to the other until ten years from signing of the agreement or any extension thereto which may be agreed upon by the Parties in writing. Proprietary information relevant to the Program detailed in Exhibit 1, already made available to the other contractual Party before the effective date, shall also be protected under this Agreement.

It is understood by the parties that, prior to disclosure, the Disclosing Party shall have obtained any government authorisation needed for the export of the Proprietary Information

12. The expiry of the period contemplated in Article 11 of this Agreement shall not relieve the receiving Party from complying with the obligations imposed by Article 4 here above with respect to the use and protection of the Proprietary Information, received prior the date of such expiry, for a period of ten (10) years after such expiry.
13. The Parties are independent contractors. Each will bear all costs and expenses in connection with this Agreement. This Agreement is intended to facilitate only the exchange of Proprietary Information and is not intended to be, and shall not be construed to create a teaming agreement, joint venture, association, partnership, or other business organisation or agency arrangement and no Party shall have the authority to bind the other without the other Party's separate prior written agreement .
14. This Agreement shall be governed by and shall be interpreted in accordance with the substantive federal laws of Switzerland excluding it's choice of law rules.

Irrespective of the foregoing each Party shall remain bound by the provisions of its own national laws and regulations with respect to the transfer or use of Classified Information or information whose export is subject to an export license.

15. All disputes among the Parties, in connection with or arising out of the existence, validity, construction, performance and termination of this Agreement (or any terms thereof), which the Parties are unable to resolve among themselves, shall be finally settled by an Arbitration. The Arbitration shall be held in Geneva (CH) in English language, in accordance with the rules of the ICC – International Chamber of Commerce by three arbitrators appointed in accordance with said rules.
16. The foregoing constitutes the entire Agreement among the Parties with respect to the subject matter hereof and supersedes and cancels all prior representations, negotiations, commitments, undertakings, communications, either oral or written, acceptances, understandings and agreements among the Parties with respect to or in connection with any of the matters to which such Agreement applies or refers.
17. Notices to _____ (**Name of Vendor**) shall be made at the following address:

(Complete Address of Vendor)

Attention: Mr. _____ (**Name of the Authorised Person of Vendor**)

Notices to BHEL shall be made at the following address:

BHARAT HEAVY ELECTRICALS LIMITED,
HEAVY ELECTRICAL EQUIPMENT PLANT,
Ranipur, Haridwar-249403 (Uttarakhand), India

Attention: Shri B.M.Bansal, General Manager- Materials Management

18. The effective date of this Agreement shall be the date of the last signature appearing herein.

IN WITNESS WHEREOF, each of the Parties has caused this Agreement, to be executed by its duly authorized officer.

Date :

Signed for and on behalf of

Signed for and on behalf of

(Name of Vendor)

BHEL

By:

By:

Title:

Title:

Signature:

Signature:

EXHIBIT 1

to the

NON-DISCLOSURE AGREEMENT

between

_____ **(Name of Vendor)**

and

BHARAT HEAVY ELECTRICALS LIMITED

dated:

The Non Disclosure Agreement covers the exchange of Proprietary Information which may occur during the discussions and negotiations in view of a possible cooperation between the Parties in the following programs:

-Description of Material or Services for which the order is placed

_____ **(Name of Vendor)** list of products that require an exchange of Proprietary Information which may be occur during the discussions and negotiations in view of a possible cooperation for the above programs :