



**MATERIALS MANAGEMENT / RM
CAPITAL PURCHASE/CP & SP
BHEL TRICHY -620014**

Enquiry Corrigendum-1

NIT – 20588

Enquiry No. 2661400872 dated 28.11.2014

Extended Due date for submission of quotation : 07.01.2015

Item Description: “Rack and pinion and machining items”

Details of Corrigendum:

*The due date of the tender is extended upto 7.1.2015. Kindly arrange to send your offer before the due date.

Drg for Rack , Drg No :3M-04D-07-15035. is uploaded.

The offer should reach us before the time (14:00) of opening of tenders.

In case the offer has been sent already, the same need not be sent again.

All other terms & conditions as published in the above NIT No. remain unaltered.

NOTE:

Confirmation of acceptance for BHEL Commercial terms & conditions & Price Bids formats have been posted in BHEL corporate website www.bhel.com or from the government tender website <http://tenders.gov.in> (public sector→Bharat Heavy Electricals Limited page) under Enquiry reference “2661400872”.

FOR BHEL TRICHY:

ASST.ENGINEER/CP&SP

THIS DRAWING IS OUR SOLE PROPERTY AND SHOULD NOT BE USED IN ANY FORM FOR ANY PURPOSE WITHOUT THE WRITTEN PERMISSION OF BHARAT HEAVY ELECTRICALS LIMITED TRICHIRAPPALLI - 620 014.

CAUTION:

ALL DIMENSIONS ARE IN MM

3.2/1.6

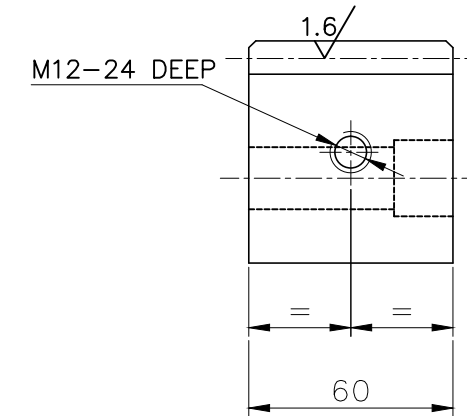
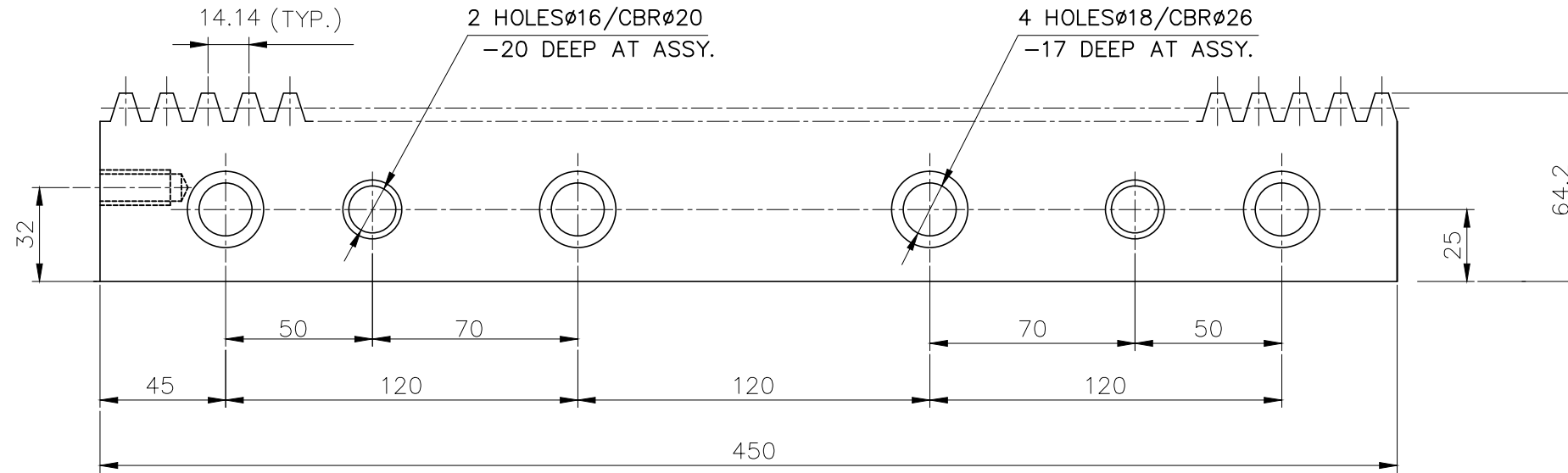

NOTE:

AVOID SHARP CORNERS

NO.OF TEETH	∞
MODULE	4.5
PRESSURE ANGLE	20°
AXIAL PITCH	14.14
MATING GEAR NO.OF TEETH	14
MATING GEAR DRG. NO.	3M04D0715036 3M04D0715037

65x60x450 L		45 C8	IS: 7283	13.68		
No. of Pieces	DESCRIPTION	MATERIAL	STANDARD	NET.WT.IN KGS.	DRAWING No.	ITEM No.
	REFERENCE:		ALTERATIONS:	DCN REF	DATE	SIGN.
SCALE	DRN.. P.Albert Ross					
1:2	CHD. G.Govindaraj					
	APP. K.Ramanan					
	DATE 03-01-13					
MACHINE:	N.C GANTRY DRILLING		TYPE:	Y 1208		
TITLE:	RACK 450 L (X-AXIS)		DRAWING No:	3M04D0715035		
			Sheet No:		No. of Sheets:	