

FIRST ANGLE PROJECTION

ALL DIMENSIONS ARE IN mm.

REV 0 3 980 08 00222 DRG No.

THE INFORMATION ON THIS DOCUMENT IS THE PROPERTY OF BHARAT HEAVY ELECTRICALS LIMITED., IT MUST NOT BE USED DIRECTLY OR INDIRECTLY IN ANY WAY DETRIMENTAL TO THE INTEREST OF THE COMPANY

SIGN AND DATE REF. DRG. No.

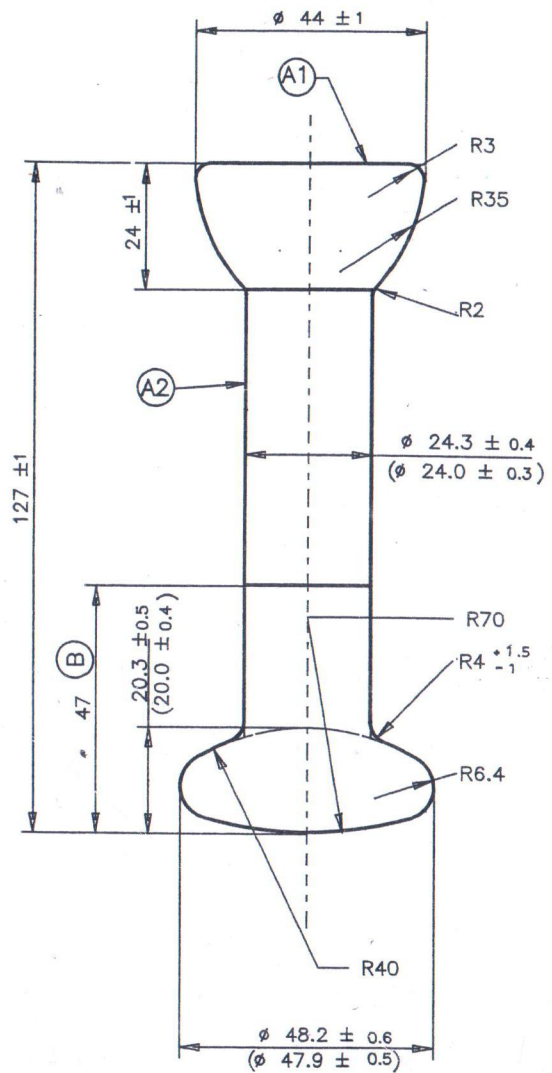

NOTES :

- ALL DIMENSIONS ARE AFTER HOT - DIP GALVANISING. A THICKNESS OF 0.15 mm MAY BE ASSUMED FOR GALVANISING.
- DIMENSIONS INDICATED IN BRACKETS REFER TO BEFORE GALVANISING STAGE.
- BALL PINS ARE TO BE MADE BY FORGING PROCESS ONLY
- MATERIAL TO CONFORM TO PURCHASING SPECIFICATION, EL-PS-36-00103 (LATEST REVISION)
- IF THE FORGED SURFACE IS NOT SMOOTH AT PORTION (B) BALL PINS ARE TO BE MACHINED AT THAT PLACE WITH THE HELP OF A 'FORM TOOL' TO GET A SMOOTH SURFACE
- AFTER GALVANISING THE BALL PIN PORTION SHOULD ANSWER TO ALL THE RELEVANT 'GO & NOT GO' GAUGES RECOMMENDED BY IEC Pub.120 (LATEST) 24 mm DESIGNATION UP TO PORTION (B)
- SUPPLIER'S IDENTIFICATION MARK TO BE PROVIDED IN DEPRESSED FORM AT (A1) OR (A2)
- SEQUENCE OF OPERATIONS :  
 A) BALL PINS ARE TO BE NORMALISED AFTER FORGING  
 B) MACHINING (IF NECESSARY - SEE NOTE 5)  
 C) SHOTBLASTING  
 D) GALVANISING
- BEFORE GALVANISING THE BALL PIN PORTION SHOULD ANSWER TO 'GO & NOT GO' GAUGES TO DRG. 4 SK 1201, 4 SK 1202 & CLAUSES - B7, B8 & B9 OF IEC Pub.120 OF 24mm DESIGNATION UP TO PORTION (B)
- BALL PINS SHALL WITHSTAND A MINIMUM TENSILE STRENGTH OF 252 kN

CONTROLLED COPY

INVENTORY No.	REV	DATE	ALTERED	REV	DATE	ALTERED	REV	DATE	ALTERED	DEPT	GRADE OF TOL DIM	SCALE	WEIGHT (kg)	REF TO ASSY.DRG	ITEM No.	No.OF ITEMS
			CHECKED	02	29/3/00	CHECKED	01	27/4/95	CHECKED			1:1	0.7 (Approx)			
	In Note No.8 Sub No.'C' MODIFIED			Material was "GRADE 080M40 of BS 970:Part 1 was 280 kN.			Ref PH No.3429			TITLE		BALL PIN		DRAWING No.		REV.
	RefPH No.4124			Ref PH No.3429			FOR 24 mm DESIGNATION OF 170 mm SPACING				CARD CODE		3 980 08 00222		02	
														SHEET No.	No.OF SHEETS	

FERROUS PARTS ATRE HOT-DIP GALVANIZED (EXCEPT FEMALE THREADS) AS PER IS: 2629 AND TESTS CONFORM TO IS:2633



**BHARAT HEAVY ELECTRICALS LTD.,**  
ELECTROPORCELAINS DIVISION  
BANGALORE - 560 012

DRN	NAME	SIGN	DATE
CHD	N.K.IDDALAGI	N.K. Idalagi	18.02.1995
APPD	B R K	B Ramakrishna	15.3.95
	N D K		15.3.95

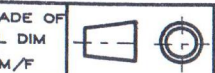

DEPT CODE

DRAWING No. 3 980 08 00222 REV. 02