



An ISO 9001  
Company

**Bharat Heavy Electricals Limited**  
(High Pressure Boiler Plant)  
Tiruchirappalli – 620014, TAMIL NADU, INDIA  
**MATERIALS MANAGEMENT**

<b>TITLE :</b> <b>SUPPLY OF FASTENERS</b>	Phone: +91 431 2577419 Email : <a href="mailto:cmuthuvel@bheltry.co.in">cmuthuvel@bheltry.co.in</a>
--	--

<b>Reference Number:</b> <b>Enquiry 1901500092-27</b>	<b>Enquiry Date:</b> 13.03.2015	<b>Due date for submission of quotation:</b> <b>30.03.2015</b>
You are requested to quote the Enquiry number date and due date in all your correspondences. This is only a request for quotation and not an order		

**CORRIGENDUM**

<b>Details of Corrigendum</b>
<i>In the referred enquiry, the omitted Page.2 of 2 of the specification BPS.41324 Rev.03 is attached herewith.</i>

BHEL tender document, commercial terms & conditions with Price Bid formats and all annexures can be downloaded from BHEL's website <http://www.bhel.com> (Tenders notification page) or from the Govt. Tenders website <http://tenders.gov.in> (Public Sector Units > Bharat Heavy Electricals page) against Ref. No. **NIT\_21786** or from <http://eprocure.gov.in> against Ref No: **2015\_BHEL\_287033\_1**

Tenders should reach us before 14:00 hours on the due date Technical bid will be opened at 14:30 hours on the due date Tenders would be opened in presence of the tenderers who have submitted their offers and who may like to be present.	Yours faithfully, <b>For Bharat Heavy Electricals Limited</b> 
---	---

**MUTHUVEL. G.**  
Manager  
Purchase / PSS  
Materials Management  
BHEL, TRICHY - 620 014.



# PLANT STANDARD

HPBP TIRUCHIRAPPALLI

BPS	41324
Rev. No.	03
PAGE	2 OF 2

## 3.2 Ordering Description

For placing indents, issuing enquiries and on purchase order, Ordering Description given below shall be followed. (Typical examples)

Hex Nut M10 to BPS : 41324-A-ASTM A 194 Gr 7 for sizes upto M16  
 Hex Nut M30 to BPS : 41324-B-ASTM A 194 Gr 7 for sizes M20 to M30  
 Hex Nut M36x3 to BPS : 41324-C- ASTM A 194 Gr 7 for sizes M36x3 and above

## 4.0 ADDITIONAL INFORMATION

4.1 Copies of this standard and TDC: 5:166 shall be enclosed along with the purchase order.

FIG 1 DIMENSIONS FOR HEXAGON NUTS (All dimensions are in millimeters)

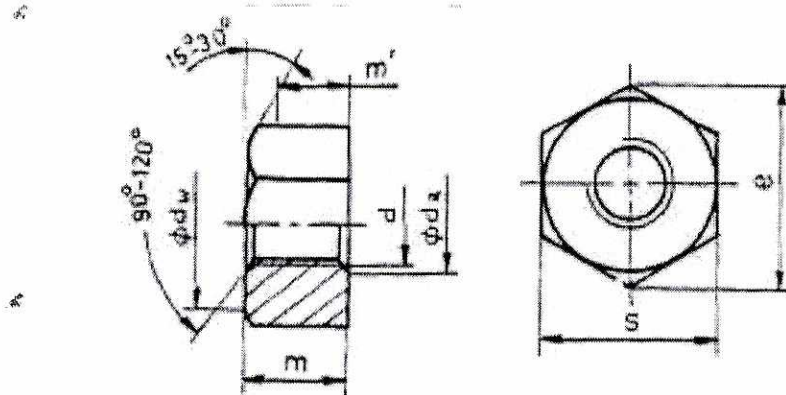

'm' = Effective gauging height

TABLE 1 (All dimensions are in millimeters)

Thread size d	d <sub>a</sub>		d <sub>w</sub> Min	e		m		M' Min	s		Weight
	Min	Max		Max	Min	Max	Min		Max	Min	
M10	10	10.8	14.6		17.77	10	9.64	7.7	16	15.73	10.8
M12	12	13.0	16.6		20.03	12	11.57	9.3	18	17.73	16.5
M16	16	17.3	22.5		26.75	17.1	16.40	13.1	24	23.67	33.0
M20	20	21.6	27.7		32.95	20.7	19.40	15.5	30	29.16	64.5
M24	24	25.9	33.2		39.55	24.2	22.90	18.3	36	35.0	110.0
(M27)					45.20	27.6	26.30	21.0	41	40.0	166.0
M30	30	32.4	42.7		50.85	30.7	29.10	23.3	46	45.0	231.0
M36x3	36	38.9	51.1		60.79	36.6	35.00	28.6	55	53.8	364.0
(M48x3)					86.5	48	46.40	37.1	75	73.8	935.0
M60x4	60	64.8			104	48	47		90	88.6	1625
M72x4	72	77.8			121	72	71		105	103.6	3020
M95x4	95	102.6			190	95	94		164.5	163	12200
M36x4	36	38.9	51.3	60.8	61.02	36	34.40	27.5	55	54	430
M42x4.5	42	45.4	60.8	75.1	72.32	42	40.40	32.3	65	64	810
M48x5	48	51.8	70.3	86.5	83.62	48	46.40	37.1	75	74	1240
M56x4	56	60.5	79.6	98	94.69	56	54.10	43.3	85	83.8	1760
M64x4	64	69.1	88.5	110	105.2	54	52.10	41.7	95	93.1	2460

### NOTE:

- Sizes in brackets are non-preferred
- Weights are given in Kg per 1000 numbers only