

ROTOR STAMPING ITEM NO. 01

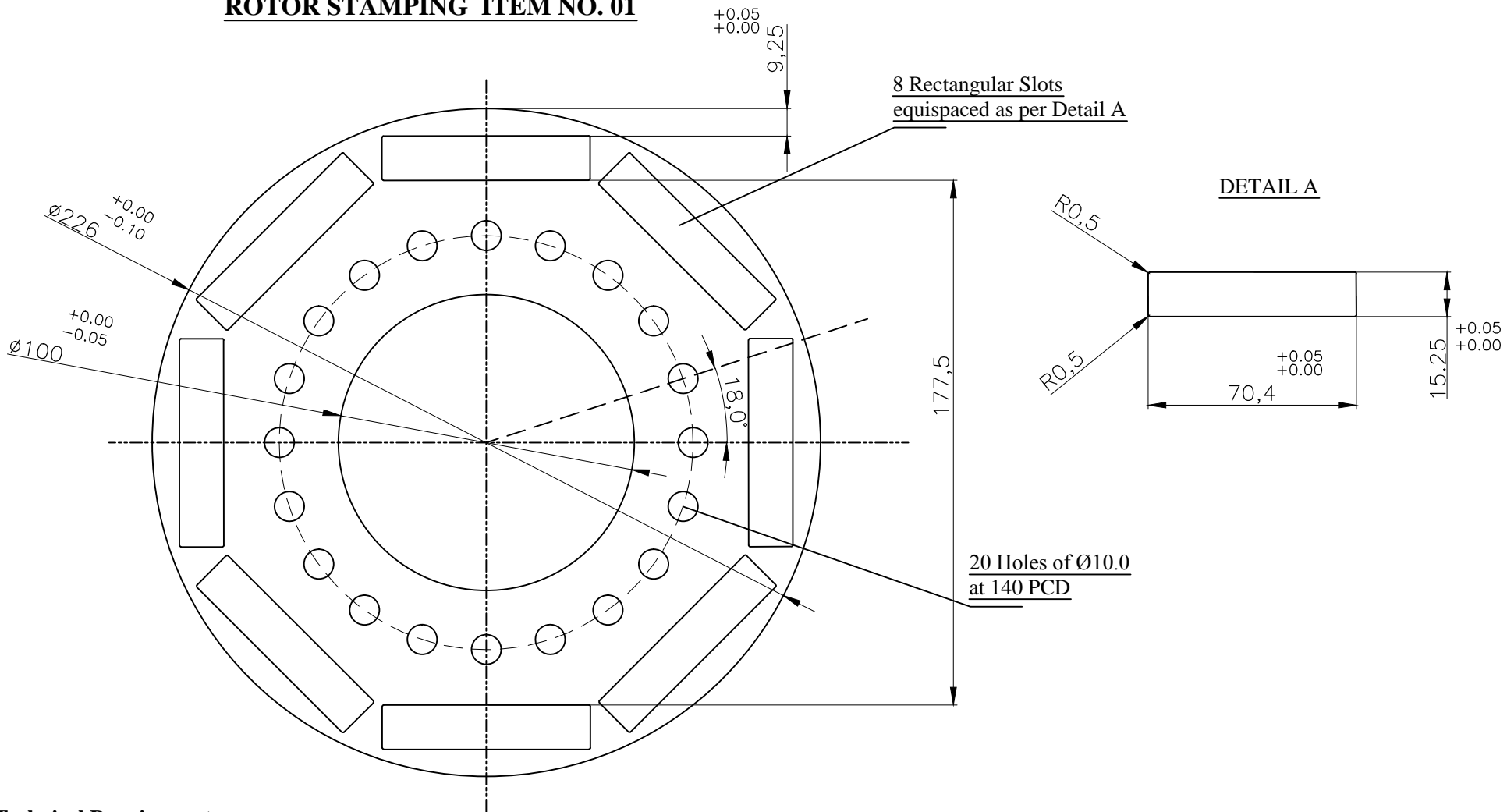

Technical Requirements:

- Quantity : 3000 no.s
- Required Die punching tools are to be developed and have to be supplied to BHEL along with the material.
- ID Cuts generated from the Stator stampings are to be used for punching the Rotor stampings.
- The dimension 9.25 above the rectangular slots is to be maintained accurately as per tolerances.

TYPE OF PRODUCT OR NAME OF CUSTOMER/PROJECT		PMSM - 150			
	BHARAT HEAVY ELECTRICALS LIMITED		NAME	SIGN.	DATE
	Corp. R&D Division, Vikasnagar HYDERABAD - 500 093		DRN.	GVN	
			CHD.	GVN	
		APPD.		SKR	
DEPT.		SCALE	WEIGHT(Kg)	REF. TO ASSY DRG.	ITEM NO.
CODE					01
TITLE			DRAWING NO.		REV.
Rotor Stamping (Item no. 01)			2DC157050002		00
SHEET NO.				NO OF SHEETS	

REV.	DATE	ALTERED	APPD.	REV.	DATE	ALTERED	APPD.	REV.	DATE	ALTERED	APPD.	REV.	DATE	ALTERED	APPD.
		CHECKED				CHECKED				CHECKED				CHECKED	
ZONE				ZONE				ZONE				ZONE			

INVENTORY NO. REF.DRGING. COMP. FILE NAME THE INFORMATION ON THIS DOCUMENT IS THE PROPERTY OF BHARAT HEAVY ELECTRICALS LIMITED. IT MUST NOT BE USED DIRECTLY OR INDIRECTLY IN ANY WAY DETRIMENTAL TO THE INTEREST OF THE COMPANY.