



AN ISO 9001
COMPANY

Bharat Heavy Electricals Limited
(A Govt. of India Undertaking)
High Pressure Boiler Plant, Tiruchirappalli 620 014, India
Phone: (0431) 2577378
e mail : rrvavic@bheltry.co.in

Ref: 2661500169 / 75

Date: 10.06.2015

CORRIGENDUM No. 1

With reference to BHEL enquiry ref: 2661500169 - 75 Dt. 22.05.2015, hosted in BHEL & NIC Portal vide reference: NIT – 22657, for our requirement of LPG Heaters for LPG Vapourisers.

The following amendment is issued with respect to Tender specification and tender due date for submission of offer has been extended upto 14.00 Hrs of 23.06.2015. Tenders will be opened at 14.30 Hrs on 23.06.2015.

Enquiry ref no. / Date	Original	Amendment
2661500169– 75 Dt. 22.05.2015 Enq sl no. 30	LPG Heater-12KW, BRASS FLANGE 2.5INCH BSP 12 KW heater consisting of 3 heating elements each of 4KW at 230 volts made out of minimum 10mm diameter copper tube nickel plated fixed to 2.5 inches BSPP brass flange complete with brass M6 terminal and overall dimensions shall be as per BHEL Drawing No.2-E-20B25-05264.	LPG Heater-12KW, BRASS FLANGE 2.5INCH BSP 12 KW heater consisting of 3 heating elements each of 4KW at 230 volts made out of minimum 10mm diameter copper tube nickel plated fixed to 2.5 inches BSPP brass flange complete with brass M6 terminal and overall dimensions shall be as per BHEL Drawing No.2-E-20B25-05264 - REV -1 (Attached)
2661500169– 75 Dt. 22.05.2015 Enq sl no. 40.	LPG Heater - 15KW, BRASS FLANGE 3 INCH BSP 15 KW heater consisting of 3 heating elements each of 6KW at 230 volts made out of minimum 10mm diameter copper tube nickel plated fixed to 3 inches BSPP brass flange complete with brass M6 terminal and overall dimensions shall be as per BHEL Drawing No.3E20B2515092 Rev01.	LPG Heater - 15KW, BRASS FLANGE 3 INCH BSP 15 KW heater consisting of 3 heating elements each of 5KW at 230 volts made out of minimum 8mm diameter copper tube nickel plated fixed to 3 inches BSPP brass flange complete with brass M6 terminal and overall dimensions shall be as per BHEL Drawing No.3E20B2515092 Rev01.
Due date	Original due date - 16.06.2015	Extended due date - 23.06.2015

The offers shall be submitted before the due date & time.

All other terms & conditions of the tender remain same.

R. RAVICHANDRAN
Manager
Purchase / MM / RM / CP & SP
BHEL, TIRUCHY - 620 014

Regd. Office: BHEL House, Siri Fort, New Delhi - 110 049

ALL DIMENSIONS ARE IN MILLIMETERS

ITEM NO : 30 (ENG NO. 2661500169)

DRAWING NO. 2-E-20B25-05264

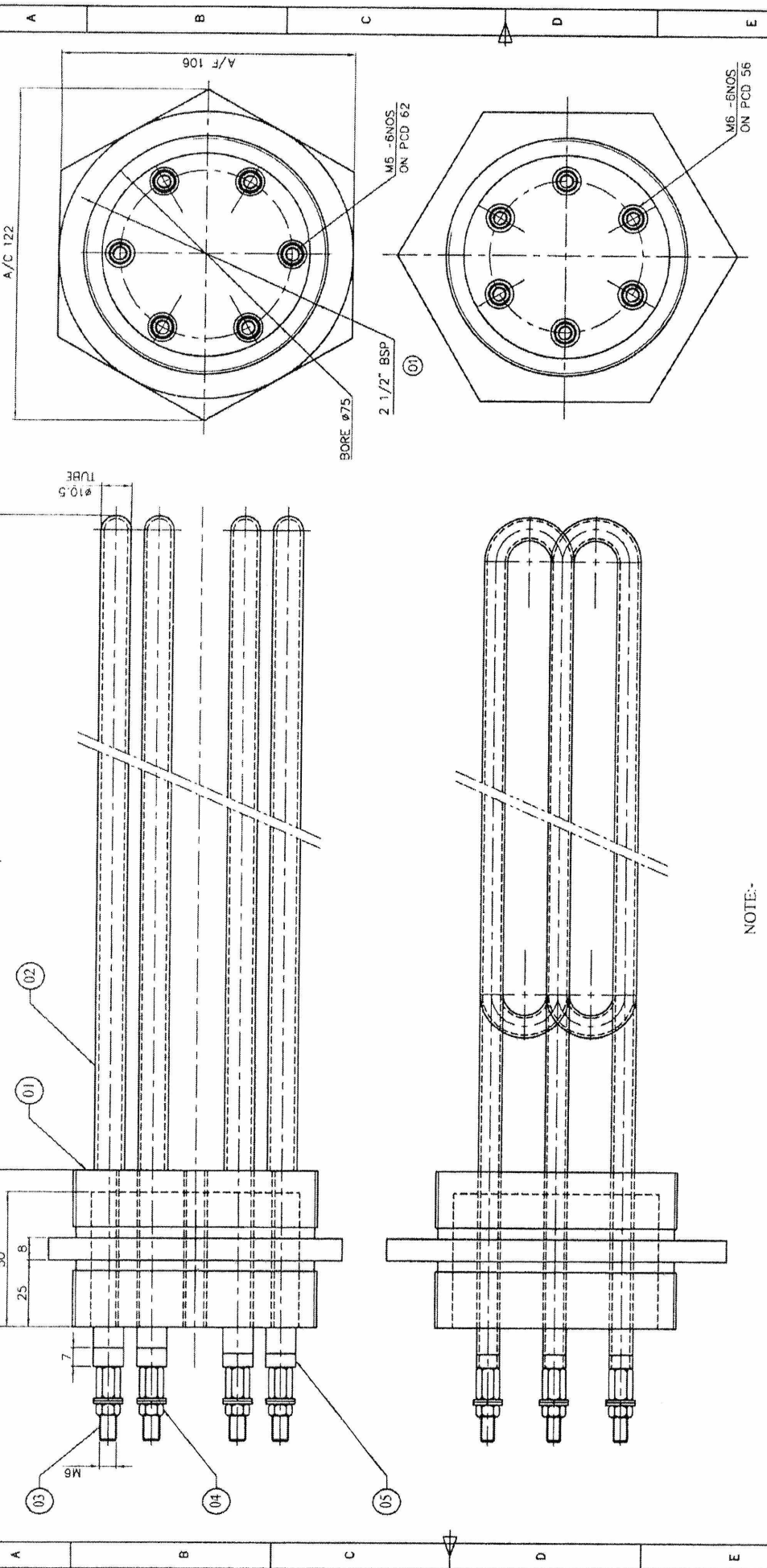

NOTE:-
 1. ITEM NO 02. TUBE OUTSIDE NICKAL PLATED
 2. INSIDE ELEMENT MATERIAL "KANTHAL D"

01	FLANGE	IS 28	PHOSPHOR BRONZE GR. 1	UNIT WT	
	DESCRIPTION	DRAWING NO	MATL. SPEC	QTY	
ECHT: GAS PLANT / LPS Bharat Heavy Electricals Ltd HIGH PRESSURE BOILER PLANT TIRUCHIRAPPALLI - 620014 SCALE 1:2 WEIGHT (KG) 1.1 REF TO STD SPEC NO. 2-E-20B25-05264 DRAWING NO. 2-E-20B25-05264 HEATING ELEMENT (500KG / hr. & 12KW)					

05	INSULATOR Ø10.5 / 5 x 7L	PORCELAIN	IS 1363	6
04	HEX LOCK NUT M6		IS 2004	12
03	STUD M6 x 35L	45 CB	IS 4170	6
02	TUBE Ø10.5x1t. x 2160L	CuZn 30		3

REV 1 DATE 19/12/14
 BY 110.04.15
 CHECKED 11/01/15
 APPROVED 05/01/15
 SCALE 2 1/2" MAX 5"

CAUTION: THE INFORMATION ON THIS DOCUMENT IS THE PROPERTY OF BHARAT HEAVY ELECTRICALS LIMITED. IT MUST NOT BE USED DIRECTLY OR INDIRECTLY IN ANY MANNER WITHOUT THE WRITTEN PERMISSION OF THE COMPANY. ANY REPRODUCTION OF THIS DOCUMENT IS STRICTLY PROHIBITED.