



An ISO 9001
Company

Bharat Heavy Electricals Limited
(High Pressure Boiler Plant)
Tiruchirappalli – 620014, TAMIL NADU, INDIA
MATERIALS MANAGEMENT

TITLE : SUPPLY OF PUNCHED WASHER	Phone: +91 431 2577419 Email : cmuthuvel@bheltry.co.in
--	---

Reference Number: Enquiry 1901500136-27	Enquiry Date: 03.06.2015	Due date for submission of quotation: 17.06.2015
You are requested to quote the Enquiry number date and due date in all your correspondences. This is only a request for quotation and not an order		

CORRIGENDUM

Details of Corrigendum
<i>The above referred enquiry opening due date has been extended from 17.06.2015 to 20.06.2015 and BPS - 41408 is also attached.</i>

BHEL tender document, commercial terms & conditions with Price Bid formats and all annexures can be downloaded from BHEL's website http://www.bhel.com (Tenders notification page) or from the Govt. Tenders website http://tenders.gov.in (Public Sector Units > Bharat Heavy Electricals page) against Ref. No. NIT_22847 or from http://eprocure.gov.in against Ref No: 2015_BHEL_1433_1	
Tenders should reach us before 14:00 hours on the due date Technical bid will be opened at 14:30 hours on the due date Tenders would be opened in presence of the tenderers who have submitted their offers and who may like to be present.	Yours faithfully, For Bharat Heavy Electricals Limited

Handwritten signature
10/6/15
A. S. S. S. S. S.
MATERIALS MANAGEMENT
BHEL TIRUCHIRAPPALLI



PLANT STANDARD

HPBP TIRUCHIRAPPALLI

BPS 41408

Rev. No. 02

PAGE 1 OF 2

PUNCHED WASHERS - TYPE A

1.0 SCOPE

Covers the requirements for punched washers Type A in the size range 61 to 78 mm.

2.0 SPECIFICATION AND REFERENCE STANDARDS

	Figure 1 and Table 1 of this standard	
	Suitable steel	
	Natural finish	
	Indian Standard	IS 6821 and IS 5369
Washers shall comply with IS 2016 in respect of requirements not covered in this standard.		

2.1 Referred Standards (Only current versions are applicable)

IS 2016	Specification for plain washers.
IS 5369	General requirements for plain washers and lock washers.
IS 6821	Methods for sampling non-threaded fasteners.

3.0 DESIGNATION

A punched washer of size 61 to this standard for bolt/screw size M56 shall be designated as :

3.1 On Drawings

i) Material Specification column	:
ii) Description column	:	PUNCHED WASHER A 61
iii) Drawing Number column	:	BPS 41408
iv) Material Code column	:	4140800056

3.2 Ordering Description

For placing indents, issuing enquiries and on purchase order, ordering description given below shall be followed (typical examples).

Punched Washer A61 to BPS 41408

Revisions **02**
Brought upto date

Approved
STANDARDS SECTION
CONTRACT ENGINEERING AND CO-ORDINATION
HPBP, TIRUCHIRAPPALLI

Rev. No. 02	Amd. No.	Reaffirmed	Prepared	Issued	Dt of 1st Issue
Dt. JUNE 1997	Dt.	Year	STANDARDS	STANDARDS	DEC 1986

4.0 ADDITIONAL INFORMATION

- 4.1 These washers can be used with Product Grade C general purpose bolts and screws.
- 4.2 Copies of this standard shall be enclosed alongwith the purchase order.

Figure - 1

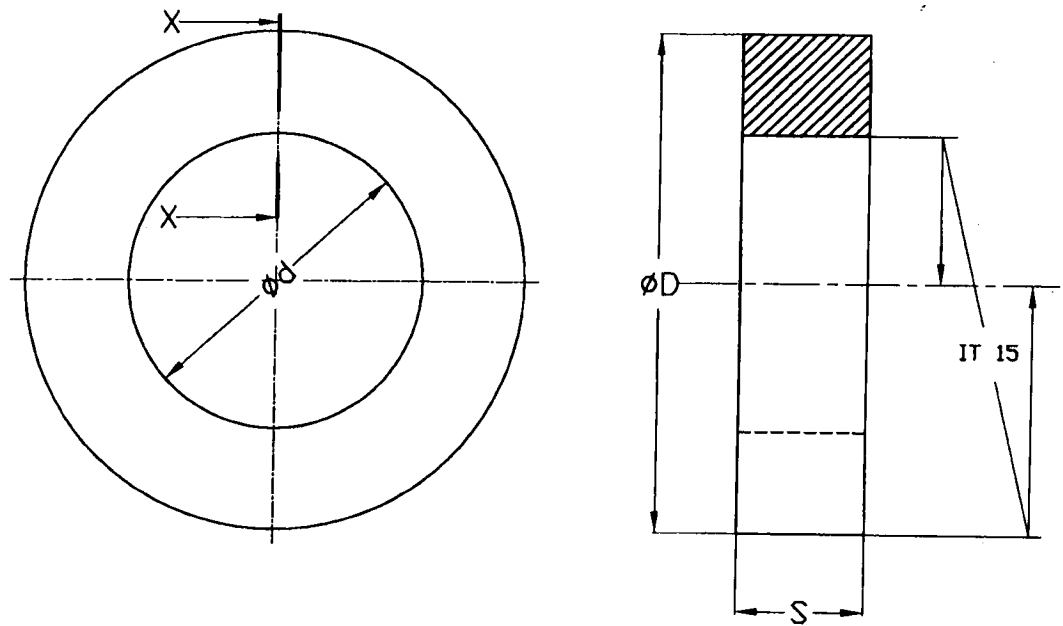

Table - 1

(All dimensions are in millimetres)

Size ø d	ø D Nmm	s Nom	For bolt/screw size	Weight
61	105	9.0	M56	405.0
78	122	10.0	M72	543.0

NOTE:

- Weights are given in Kg per 1000 numbers.