

Bharat Heavy Electricals Limited
(High Pressure Boiler Plant) Tiruchirappalli – 620014,
TAMIL NADU, INDIA an ISO 9001
CAPITAL PURCHASE / MATERIALS MANAGEMENT / MFG

ENQUIRY – Corrigendum 1	Phone: +91 431 257 7645 Fax : +91 431 252 07 19 Email : pgavictor@bheltry.co.in Web : www.bhel.com / www.tenders.gov.in
--------------------------------	---

NIT_23550	Enquiry Number: 2681500009	Enquiry Date: 23.07.15	Revised due date for submission of quotation : 01.09.15
------------------	--------------------------------------	----------------------------------	--

You are requested to quote the Enquiry number date and due date in all your correspondences. This is only a request for quotation and not an order

ITEM DESCRIPTION: Supply of Trolley assembly with hoist, CT< Mechanism for Gantry Crane

Details of Corrigendum

The above mentioned tender due date has been extended up to **01.09.15** due to administrative reasons and tender will be opened at 14:30 Hrs on the same *day*.

Drawing no. **3M02R0011993** has been enclosed along with this corrigendum as per tender descriptions.

All other terms and conditions as published in the NIT_23550 remain unaltered

Confirmation of acceptance for BHEL commercial terms & conditions and Price Bid formats have been posted in BHEL Corporate web site www.bhel.com or from the Government tender website <http://tenders.gov.in> (public sector units > Bharat Heavy Electricals Limited page) under Enquiry reference “2681500009”.

Tenders should reach us before 14:00 hours on the due date Tenders will be opened at 14:30 hours on the due date Tenders would be opened in presence of the tenderers who have submitted their offers and who may like to be present	Yours faithfully,  For BHARAT HEAVY ELECTRICALS LIMITED Manager, Capital Purchase P. C. ABRAHAM VICTOR Senior Manager Purchase / MM / MFG BHEL, TRICHY - 620 014
--	--

CAUTION: THIS DRAWING IS OUR SOLE PROPERTY AND SHOULD NOT BE USED IN ANY FORM FOR ANY PURPOSE WITHOUT THE WRITTEN PERMISSION OF BHARAT HEAVY ELECTRICALS LIMITED TRICHIRAPPALLI - 620 014.

ALL DIMENSIONS ARE IN MM

SL. No.	O.D. (WHEEL DIA) IN MM	RAIL SIZE	A	B	D	E	F	ØG	H	ØJ	K	L	Ød	M (KEY)	N	P	Q	S	R	COUPLING No.	SKF BRG No. & BRG. SIZE	TOTAL WEIGHT IN Kg. FOR DRIVE & IDLE
16	800/850	CR-100 CR-120	190	450	80	210	150	152	140	130	212	255	32	32x18x130	687	588	20	150	80	107	22330 150x320x108	870.00 845.00
15		CR-80	168	420	80	180	110	152	125	110	212	255	32	28x16x115	687	588	20	150	80	106	22330 150x320x108	796.00 775.00
14	710/750	CR-100 CR-120	190	450	80	210	150	152	140	130	212	255	32	32x18x130	642	588	20	150	80	107	22330 150x320x108	808.00 784.00
13		CR-100 CR-120	180	420	71	210	150	132	125	110	180	224	32	28x16x115	607	517	20	130	80	106	22326 130x280x93	728.50 711.50
12	630/680	CR-80	180	400	71	180	110	132	125	110	180	224	32	28x16x115	607	517	20	130	80	106	22326 130x280x93	653.00 636.00
11		CR-80/CR-100 & CR-120	180	420	71	210	150	132	125	110	180	224	32	28x16x115	567	517	20	130	80	106	22326 130x280x93	629.00 611.50
10	500/550	90-105 Lbs/Yd CR-80	150	365	60	180	105	111	110	90	160	190	26	25x14x100	547	462	20	120	60	105	22322 110x240x80	448.00 434.50
9		CR-80 CR-100	160	375	60	180	125	111	110	90	160	190	26	22x14x100	482	462	20	120	60	105	22322 110x240x80	253.00 245.50
8	400/450	CR-80	150	360	50	180	125	91	105	80	125	160	26	22x14x90	445	395	20	100	50	104	22318 90x190x64	389.00 378.00
7		60/75/90 & 105 Lbs/Yd	150	360	50	180	105	91	105	80	125	160	26	22x14x90	445	395	20	100	50	104	22318 90x190x64	301.00 294.00
6	320/370	CR-80 CR-100	150	360	50	180	125	91	105	80	125	160	26	22x14x90	395	395	20	100	50	104	22318 90x190x64	253.00 245.50
5		90 Lbs/Yd 105 Lbs/Yd	145	315	40	180	105	76	85	70	112	140	22	20x12x75	375	345	16	90	50	103	22315 75x160x55	197.00 192.00
4	250/280	75 / 90 & 105 Lbs/Yd CR-80	145	315	40	180	105	76	85	70	112	140	22	20x12x75	345	345	16	90	50	103	22315 75x160x55	162.00 157.00
3		50 SQ.BAR 60 Lbs/Yd 75 Lbs/Yd	112.5	260	40	125	85	61	65	55	85	112	17	16x10x55	312	287	16	80	50	102	22312 60x130x46	118.50 118.00
2	200/230	50 SQ.BAR 60 / 90 & 105 Lbs/Yd	105	250	32	125	85	61	65	55	76	100	17	16x10x55	254	249	12	60	40	102	22212 60x110x28	66.00 63.00
1		30 Lbs/Yd 50 SQ.BAR 60 Lbs/Yd	95	220	32	100	67	46	55	40	71	95	17	12x8x45	239	232	12	65	40	101	22309 45x100x36	51.00 50.00

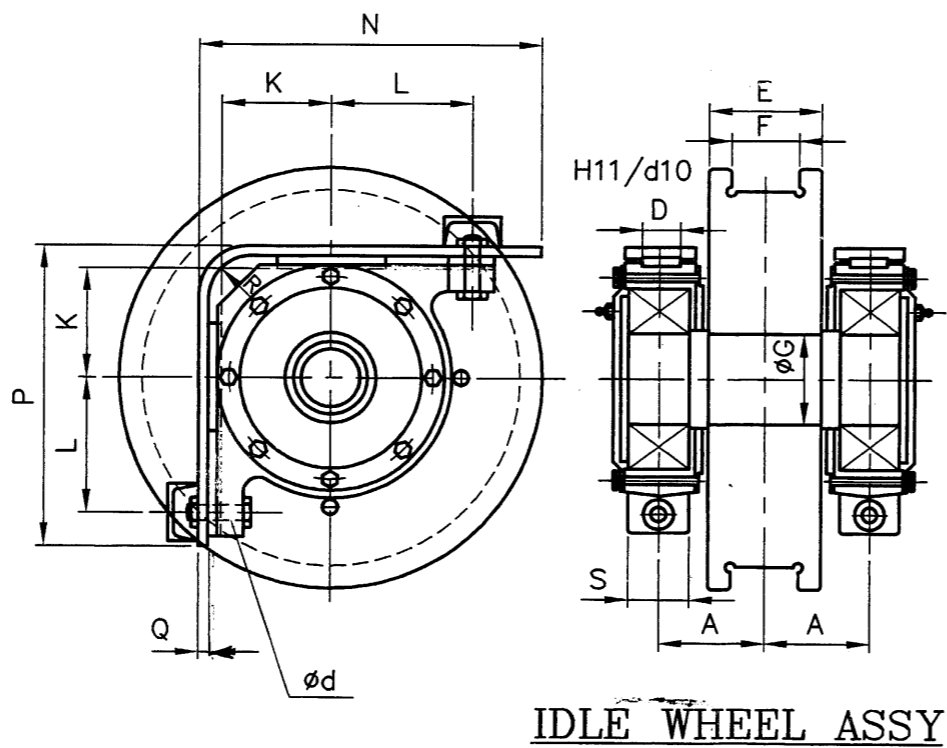
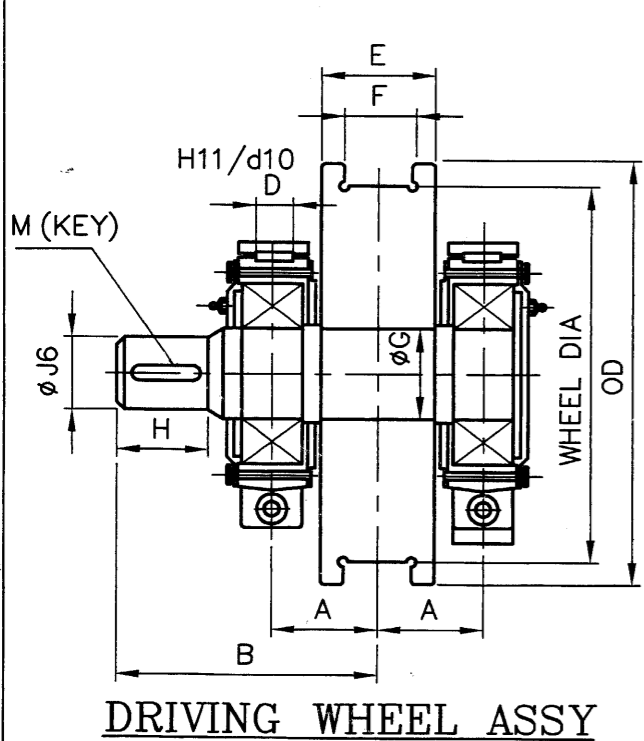

MATERIAL :- SHAFT - 45CB/IS:7283.
WHEEL - 55CB/IS:5517.
FORGED.
TREAD PORTION WHEEL HARDNESS 300 TO 350 (BHN)

No. of Pieces	DESCRIPTION	MATERIAL	STANDARD	NET.WT.IN KGS.	DRAWING No.	ITEM No.
REFERENCE:			COMPONENT CODE: 29	EQUIPMENT CODE: 00		
SCALE	DRAWN		ALTERATIONS:	DCN REF	DATE	SIGN.
	CHECKED					
	APPROVED					
	DATE	20-10-2000				
MACHINE: CRANE WHEEL ASSY			TYPE: GENERAL			
TITLE: STANDARD CRANE WHEEL ASSY			DRAWING No: 3-M-02R-11993			REV.
No. of Sheets			Sheet No:			