

Bharat Heavy Electricals Limited

[A Government of India Undertaking]



Materials Management
Tiruchirappalli - 620 014, INDIA
E mail : kvalavan@bheltry.co.in

DT: 24.11.2015

CORRIGENDA-I

Ref: 1. NIT-25251

2. 2015_BHEL_56773_1

CORRIGENDA-I TO OUR ENQUIRY Ref: 1901500278 DT 16.11.2015

FOR THE SUPPLY of CTR WOODEN BOXES due on 02.12.2015

- 1) The final date of delivery schedule i.e. validity of Rate Contract for all the items have been changed as 31.01.2017,
- 2) Due date of Quotation is changed as 05.12.2015,
- 3) Kindly read Point No.4 under Enclosure as "ANNEXURE-N-TO BE SUBMITTED BY ALL VENDORS" in Page No.5/5 of Enquiry,
- 4) Corrected Annexure-C (Price Bid Format) attached and
- 5) Drawings as per Annexure-C, test certificate format and Specification copy enclosed.

R.KILLIVALAVAN
ENGINEER/PURCHASE/PSS



BHARAT HEAVY ELECTRICALS LIMITED

(A Government of India Undertaking)
HIGH PRESSURE BOILER PLANT
PURCHASE DEPARTMENT - FOSSIL BOILERS
THIRUCHIRAPALLI - 620014
TAMILNADU (INDIA)

PHONE :2677419
GRAMS : BHARATELEC
FAX NO: 2520719
E-mail: cmuthuvel@bheltry.co.in
Web:

429-002/A

Enquiry No	Enquiry Date	Due Date for Quotation
1901500278 - 53	16.11.2015	05.12.2015
Please quote Enquiry No, Date and due date in all correspondences. This is only a request for quotation and not an order. <i>Bid should be submitted in two parts. 1.Tech-commercial bid (Part-I) and 2.Price bid(Part-II) in a separate sealed cover and both covers must be placed in a third cover and sealed. Our Enquiry No., Enq. date & Enq. Due date must be written on all three covers.</i>		

Item	Description	Unit	Quantity	Delivery Quantity	Schedule Date
10	200054040000 K.S.CHEM.T.R.W BOXES 600X500X400 mm K.S.CHEM.T.R.W BOXES 600X500X400 mm	NO	325.000	325.00	31.01.17
20	200054050000 K.S.CHEM.T.R.W BOXES 900X800X600MM K.S.CHEM.T.R.W BOXES 900X800X600MM	NO	750.000	750.00	31.01.17
30	200054060000 K.S.CHEM.T.R.W BOXES 1200X900X600MM K.S.CHEM.T.R.W BOXES 1200X900X600MM	NO	650.000	650.00	31.01.17
40	200054070000 K.S.CHEM.T.R.W BOXES 1300X900X900 mm K.S.CHEM.T.R.W BOXES 1300X900X900mm	NO	710.000	710.00	31.01.17
50	200054080000 K.S.CHEM.T.R.W BOXES 1500X700X700 mm K.S.CHEM.T.R.W BOXES 1500X700X700 mm	NO	700.000	700.00	31.01.17
60	200054090000 K.S.CHEM.T.R.W BOXES 1050X1050X500MM K.S.CHEM.T.R.W BOXES 1050X1050X500MM	NO	300.000	300.00	31.01.17
70	200054100000 K.S.CHEM.T.R.W BOXES 1600X900X1000MM K.S.CHEM.T.R.W BOXES 1600X900X1000MM	NO	450.000	450.00	31.01.17
80	200054110000 K.S.CHEM.T.R.W BOXES 800X200X200 mm K.S.CHEM.T.R.W BOXES 800X200X200 mm	NO	90.000	90.00	31.01.17
90	200054120000 K.S.CHEM.T.R.W BOXES 1500X200X200 mm K.S.CHEM.T.R.W BOXES 1500X200X200 mm	NO	40.000	40.00	31.01.17
100	200054130000 K.S.CHEM.T.R.W BOXES 2000X200X200 mm K.S.CHEM.T.R.W BOXES 2000X200X200 mm	NO	25.000	25.00	31.01.17

The offers should reach us 30 minutes before the time of opening of tenders.
The offers will be opened at 14.30 hrs on the due date of tender in the presence of tenderers who have submitted their offer and who may like to be present for the tender opening.Late and delayed offers are liable to be rejected.

VIGILANCE AWARENESS WEEK

26 th OCT to 31st OCT 2015

FOR VIGILANCE RELATED COMPLAINTS.

CONTACT DGM/VIGILANCE & SM/VIGILANCE

PHONE:0431-2577552,2577636

Yours faithfully,
For BHARAT HEAVY ELECTRICALS LIMITED

R. KILLIVALAVAN
Engineer
PURCHASE / PSS / MM
BHEL, TRICHY - 620014.

MANAGER / PURCHASE
(FOSSIL BOILERS)
Yours faithfully,



BHARAT HEAVY ELECTRICALS LIMITED

(A Government of India Undertaking)
 HIGH PRESSURE BOILER PLANT
 PURCHASE DEPARTMENT - FOSSIL BOILERS
 THIRUCHIRAPALLI - 620014
 TAMILNADU (INDIA)

PHONE :2577419
 GRAMS : BHARATELEC
 FAX NO: 2520719
 E-mail: cmuthyvel@bheltry.co.in
 Web:

1901500278 / 16.11.2015

23505

110	200054150000	NO	120.000	120.00	31.01.17
	K.S.CHEM.T.R.W BOXES 1100X400X400 mm K.S.CHEM.T.R.W BOXES 1100X400X400 mm				
120	200054220000	NO	450.000	450.00	31.01.17
	K.S.CHEM. T.R.W. BOXES 200X200X200 mm K.S.CHEM. T.R.W. BOXES 200X200X200 mm				
130	200054250000	NO	100.000	100.00	31.01.17
	K.S.CHEM.T.R.W BOXES 1100X500X500 mm K.S.CHEM.T.R.W BOXES 1100X500X500 mm				
140	200054390000	NO	50.000	50.00	31.01.17
	Type SPR - Size 850X630X670 Box Type SPR - Size 850X630X670 Box				
150	200054450000	NO	150.000	150.00	31.01.17
	Type SPY - Size 450X200X200 Box Type SPY - Size 450X200X200 Box				
160	200150300000	NO	560.000	560.00	31.01.17
	CTR WOOD BOX T-3 CTR WOOD BOX T-3				
170	200150320000	NO	1600.000	1,600.00	31.01.17
	Chem.T.R.W. Boxes -TYPE - 2 Chem.T.R.W. Boxes -TYPE - 2				
180	200150330000	NO	1490.000	1,490.00	31.01.17
	CTR WOOD BOX T-1 CTR WOOD BOX T-1				
190	200150740000	NO	130.000	130.00	31.01.17
	CTR WOOD BOX Type 23 CTR WOOD BOX Type 23				
200	200150750000	NO	200.000	200.00	31.01.17
	CTR WOOD BOX Type 24 CTR WOOD BOX Type 24				
210	200150780000	NO	750.000	750.00	31.01.17
	CTR WOOD BOX Type-27 CTR WOOD BOX Type-27				
220	200150790000	NO	240.000	240.00	31.01.17
	CTR WOOD BOX Type 28 CTR WOOD BOX Type 28				
230	200150800000	NO	500.000	500.00	31.01.17
	CTR WOOD BOX T-4				

The offers should reach us 30 minutes before the time of opening of tenders.
 The offers will be opened at 14.30 hrs on the due date of tender in the presence of
 tenderers who have submitted their offer and who may like to be present for the tender
 opening.Late and delayed offers are liable to be rejected.

VIGILANCE AWARENESS WEEK
26 th OCT to 31st OCT 2015
FOR VIGILANCE RELATED COMPLAINTS,
CONTACT DGM/VIGILANCE & SM/VIGILANCE
PHONE:0431-2577552,2577636

Yours faithfully,
 For BHARAT HEAVY ELECTRICALS LIMITED

R. KILLIVALAVAN
 Engineer
 PURCHASE / P.S / MM
 PHEL, TRICHY

[Signature]
 MANAGER / PURCHASE
 (FOSSIL BOILERS)
 Yours faithfully,



BHARAT HEAVY ELECTRICALS LIMITED

(A Government of India Undertaking)
HIGH PRESSURE BOILER PLANT
PURCHASE DEPARTMENT - FOSSIL BOILERS
THIRUCHIRAPALLI - 620014
TAMILNADU (INDIA)

Page
3/5

PHONE :2577419
GRAMS : BHARATELEC
FAX NO: 2520719
E-mail: emuthuvel@bheltry.co.in
Web:

1901500278 / 16.11.2015		23505			
240	CTR WOOD BOX T-4 200150820000	NO	750.000	750.00	31.01.17
250	CTR WOOD BOX T-6 CTR WOOD BOX T-6 200150830000	NO	595.000	595.00	31.01.17
260	CTR WOOD BOX Type 7 CTR WOOD BOX Type 7 200150840000	NO	550.000	550.00	31.01.17
270	CTR WOOD BOX Type 10 CTR WOOD BOX Type 10 200150880000	NO	300.000	300.00	31.01.17
280	CTR WOOD BOX Type-15 CTR WOOD BOX Type-15 200150930000	NO	190.000	190.00	31.01.17
290	CTR WOOD BOX T-11 CTR WOOD BOX T-11 200150940000	NO	400.000	400.00	31.01.17
300	CTR WOOD BOX Type 12 CTR WOOD BOX Type 12 200150950000	NO	500.000	500.00	31.01.17
310	CTR WOOD BOX Type 14 CTR WOOD BOX Type 14 200150970000	NO	300.000	300.00	31.01.17
320	CTR WOOD BOX Type 17 CTR WOOD BOX Type 17 200151000000	NO	1000.000	1,000.00	31.01.17
330	CTR WOOD BOX Type-52 CTR WOOD BOX Type-52 200151010000	NO	700.000	700.00	31.01.17
340	CTR WOOD BOX Type-53 CTR WOOD BOX Type-53 200151060000	NO	170.000	170.00	31.01.17
350	CTR WOOD BOX Type 54 CTR WOOD BOX Type 54 200151080000	NO	1450.000	1,450.00	31.01.17
360	CTR WOOD BOX T-1A CTR WOOD BOX T-1A 200151090000	NO	70.000	70.00	31.01.17

The offers should reach us 30 minutes before the time of opening of tenders.
The offers will be opened at 14.30 hrs on the due date of tender in the presence of tenderers who have submitted their offer and who may like to be present for the tender opening. Late and delayed offers are liable to be rejected.

VIGILANCE AWARENESS WEEK
26 th OCT to 31st OCT 2015
FOR VIGILANCE RELATED COMPLAINTS,
CONTACT DGM/VIGILANCE & SM/VIGILANCE
PHONE-0431-2577552,2577636

Yours faithfully,
For BHARAT HEAVY ELECTRICALS LIMITED

R. KILLIVALAYAN
Engineer
PURCHASE / PSS / MM
BHEL, TRICHY - 620 014.

MANAGER / PURCHASE
(FOSSIL BOILERS)
Yours faithfully,



BHARAT HEAVY ELECTRICALS LIMITED

(A Government of India Undertaking)
HIGH PRESSURE BOILER PLANT
PURCHASE DEPARTMENT - FOSSIL BOILERS
THIRUCHIRAPALLI - 620014
TAMILNADU (INDIA)

PHONE :2577419
GRAMS : BHARATELEC
FAX NO: 2520719
E-mail: cmrthuvet@bheltry.co.in
Web:

1901500278 / 16.11.2015

23505

370	CTR WOOD BOX T-56 CTR WOOD BOX T-56 200151110000	NO	600.000	600.00	31.01.17
380	CTR WOOD BOX T-58 CTR WOOD BOX T-58 200151120000	NO	30.000	30.00	31.01.17
390	CTR WOOD BOX Type 61 CTR WOOD BOX Type 61 200151130000	NO	105.000	105.00	31.01.17
	CTR WOOD BOX Type 62 CTR WOOD BOX Type 62				

General Note:

- 1) Offers received from MSE vendors only will be considered for this Enquiry.
- 2) Placement of Purchase Order will be restricted upto L6 vendors only and split up ratio will be as per the table mentioned in Point No.20(g) of Annexure-A.
- 3) The rates should be firm for one year period from the date of finalisation of Rate Contract.
- 4) PO will be placed every month based on monthly requirement.
- 5) BHEL reserves the right to short close the rate contract anytime during the period of rate contract.
- 6) The required documents as per Annexure-A & B should be attached along with offer. Otherwise your offer will not be considered for this tender.
- 7) In case of failure in supplying the items as per PO terms and conditions within the delivery period, BHEL reserves the right to cancel the PO and share the quantity among other vendors who qualified as per the split up ratio. Also such failed vendors will be removed from Rate Contract of this Enquiry and their share quantity will be distributed equally among other qualified vendors as per the split up ratio.
- 8) Advertisement for the requirement of "WOOD: KILN SEASONED CHEMICALLY TREATED RUBBER WOOD SCANTLINGS / BOXES OF VARIOUS SIZES AS PER BHEL SPECIFICATION" is already available in BHEL website / www.bhel.com / Supplier Registration / in the heading New suppliers required.

The offers should reach us 30 minutes before the time of opening of tenders. The offers will be opened at 14.30 hrs on the due date of tender in the presence of tenderers who have submitted their offer and who may like to be present for the tender opening. Late and delayed offers are liable to be rejected.

VIGILANCE AWARENESS WEEK
26th OCT to 31st OCT 2015
FOR VIGILANCE RELATED COMPLAINTS,
CONTACT DGM/VIGILANCE & SM/VIGILANCE
PHONE:0431-2577552,2577636

Yours faithfully,
For BHARAT HEAVY ELECTRICALS LIMITED

R. KILLIVALAYAN
Engineer
PURCHASE / PSS / MM
BHEL, TRICHY - 620 014.

MANAGER / PURCHASE
(FOSSIL BOILERS)
Yours faithfully,



BHARAT HEAVY ELECTRICALS LIMITED

(A Government of India Undertaking)
HIGH PRESSURE BOILER PLANT
PURCHASE DEPARTMENT - FOSSIL BOILERS
THIRUCHIRAPALLI - 620014
TAMILNADU (INDIA)

PHONE :2577419
GRAMS : BHARATELEC
FAX NO: 2520719
E-mail: cmuthuvel@bheltry.co.in
Web:

1901500278 / 16.11.2015

23505

All the tenders may be addressed to the following address:

The Tender Opening Cell / MM
Room No: 2B, Building 24, Ground Floor
Bharat Heavy Electricals Limited
TIRUCHIRAPALLI 620014

In case personal delivery of the offer, it shall be dropped into the respective box kept in Room No: 2B, after duly entering the data in the system.

Offers will be accepted only up to 14.00 Hrs on the due date. Therefore, vendors shall ensure to submit the offers well before this time. All due date extension requirements should be addressed to the respective Purchase mail IDs. All the due date extension requests from vendors will be considered only up to 48 hours before the due date and time.

Vendors are requested to avoid submission of offers through e mail / fax. In case of any unavoidable situation, offers shall be sent through e mail to the following mail ID only tender_cell@bheltry.co.in.

As tenders are being opened by Common Tender Opening Cell, offer covers should be sealed with tenderer's distinctive seal and super scribed with correct Tender No. item of supply and due date of opening.

The offers will be opened at 14.30 hrs on the due date of the tender in the presence of tenderers who have submitted their offer and who may like to be present for the tender opening. Late and delayed offers are liable to be rejected.

The bidder along with its associate/ collaborators/ sub-contractors/ sub-vendors/ consultants/ service providers shall strictly adhere to BHEL fraud prevention policy displayed on BHEL website <http://www.bhel.com> and shall immediately bring to the notice of BHEL management about any fraud or suspected fraud as soon as it comes to their notice.

Enclosures:

ENCLOSURES:

- 1) ANNEXURE-A--TERMS AND CONDITIONS
- 2) ANNEXURE-B--COMMERCIAL TERMS
- 3) ANNEXURE-C--PRICE BID FORMAT AND
- 4) ANNEXURE-N--TO BE SUBMITTED BY ALL VENDORS
- 5) DRAWINGS AS PER ANNEXURE-C,TEST CERTIFICATE FORMAT AND SPECIFICATION COPY

"LD clause has to be confirmed without fail."

The offers should reach us 30 minutes before the time of opening of tenders. The offers will be opened at 14.30 hrs on the due date of tender in the presence of tenderers who have submitted their offer and who may like to be present for the tender opening. Late and delayed offers are liable to be rejected.

Yours faithfully,
For BHARAT HEAVY ELECTRICALS LIMITED

VIGILANCE AWARENESS WEEK
26 th OCT to 31st OCT 2015
FOR VIGILANCE RELATED COMPLAINTS,
CONTACT DGM/VIGILANCE & SM/VIGILANCE
PHONE:0431-2577552,2577636

R. KALLIVALAVAN
Engineer
PURCHASE / FSS / MM
BHEL, TRICHY - 620 014.

MANAGER / PURCHASE
(FOSSIL BOILERS)
Yours faithfully,

ENQUIRY NO:

DATE:

DUPLICATE:

ENO SL NO	MATERIAL CODE	MATERIAL DESCRIPTION	DRG.NO	QTY	BASIC PRICE INCLUSIVE OF PACKING & FORWARDING, FREIGHT & INSURANCE AND DISCOUNT	EXCISE DUTY IN %	SALES TAX IN %			OTHER COST IN ANY IN %
							VAT %	CT WITH C FORM %	CT WITHOUT C FORM %	
18	200054040000	K.S.CHEM.T.R.W BOXES 600X500X400MM	3-SH-B-004/C Rev-C	325						
20	200054050000	K.S.CHEM.T.R.W BOXES 900X600X600MM	2-SH-CRT-00002/B	750						
30	200054060000	K.S.CHEM.T.R.W BOXES 1200X900X600MM	2-SH-CRT-00002/B	650						
40	200054070000	K.S.CHEM.T.R.W BOXES 1300X900X900MM	2-SH-CRT-00002/B	710						
50	200054080000	K.S.CHEM.T.R.W BOXES 1500X700X700MM	2-SH-CRT-00002/B	700						
60	200054090000	K.S.CHEM.T.R.W BOXES 1050X1050X500MM	3-SH-B-004/C Rev-C	300						
70	200054100000	K.S.CHEM.T.R.W BOXES 1600X900X1000MM	3-SH-B-005	450						
80	200054110000	K.S.CHEM.T.R.W BOXES 800X200X200 mm	40-SPM-SH-00001/01	90						
90	200054120000	K.S.CHEM.T.R.W BOXES 1500X200X200 mm	40-SPM-SH-00001/01	40						
100	200054130000	K.S.CHEM.T.R.W BOXES 2000X200X200 mm	40-SPM-SH-00001/01	25						
110	200054150000	K.S.CHEM.T.R.W BOXES 1100X400X400MM	40-SPM-SH-00002/01	120						
120	200054220000	K.S.CHEM.T.R.W BOXES 2000X200X200 mm	40-SPM-SH-00001/01	450						
130	200054250000	K.S.CHEM.T.R.W BOXES 1100X500X500MM	3-SH-B-004/B/01	100						
140	200054390000	Type SPR - Size 850X630X670 Box	2-V-0000-05779/02	50						
150	200054450000	Type SPV - Size 450X200X200 Box	40-SPM-SH-00001/01	150						
160	200150300000	CTR WOOD BOX T-3	2-V-0000-05779/02	560						
170	200150320000	CTR WOOD BOX T-2	4-V-4000-071B3/02	1600						
180	200150330000	CTR WOOD BOX T-1	4-V-4000-071B3/02	1490						
190	200150740000	CTR WOOD BOX T-23	1-V-0000-11136/04	130						
200	200150750000	CTR WOOD BOX T-24	1-V-0000-11136/04	200						
210	200150780000	CTR WOOD BOX T-27	1-V-0000-11136/04	750						
220	200150790000	CTR WOOD BOX T-28	1-V-0000-11136/04	240						
230	200150800000	CTR WOOD BOX T-4	2-V-0000-05779/02	500						
240	200150820000	CTR WOOD BOX T-5	2-V-0000-05779/02	750						
250	200150830000	CTR WOOD BOX T-7	2-V-0000-05779/02	585						

BHARAT HEAVY ELECTRICALS LIMITED
 TRUCHIRAPPALLI - 620 015

ANNEXURE - C

PRICE BID FORMAT

ENQUIRY NO:

DATE:

DUE DATE:

ENO SL NO	MATERIAL CODE	MATERIAL DESCRIPTION	DRG. NO	QTY	BASIC PRICE INCLUSIVE OF PACKING & FORWARDING, FREIGHT & INSURANCE AND DISCOUNT	EXCISE DUTY IN %	SALES TAX IN %			OTHER COST IF ANY IN %
							VAT %	EST WITH C FORM %	EST WITHOUT C FORM %	
266	200150840000	CTR WOOD BOX T-10	2-V-0000-05779/02	550						
276	200150880000	CTR WOOD BOX T-15	2-V-0000-05779/02	300						
280	200150930000	CTR WOOD BOX T-11	2-V-0000-05780/00	180						
280	200150940000	CTR WOOD BOX T-12	2-V-0000-05780/00	400						
290	200150950000	CTR WOOD BOX T-14	2-V-0000-05779/02	500						
310	200150970000	CTR WOOD BOX T-17	2-V-0000-05780/00	300						
310	200151000000	CTR WOOD BOX T-52	2-V-4600-03636/08	1,000						
330	200151010000	CTR WOOD BOX T-53	2-V-4600-03636/08	700						
240	200151060000	CTR WOOD BOX T-54	2-V-4600-03636/08	170						
350	200151080000	CTR WOOD BOX T-1A	4-V-4000-07183/02	1450						
360	200151090000	CTR WOOD BOX T-56	2-V-4600-03636/08	70						
370	200151100000	CTR WOOD BOX T-58	2-V-4600-03636/08	600						
380	200151120000	CTR WOOD BOX T-61	1-V-0000-11136/04	30						
390	200151130000	CTR WOOD BOX T-62	2-V-7503-10122	105						

SIGN AND SEAL OF AUTHORIZED PERSON



CBF113664



SPECIFICATION FOR PACKING WOOD - RUBBER WOOD

Doc. No. PR: CHEM: 20

Rev. No.: 03

Date: 15.11.2005

1.0 SCOPE:

This specification prescribes the requirements of rubber wood intended for packing purposes.

2.0 DEFINITION:

RUBBER WOOD:- Seasoned and chemically treated rubber wood in converted form (scanlings, boxes / shooks) intended for packing cases to be stored outside and exposed.

3.0 REQUIREMENTS:

3.1 Supply of planks to shipping / FB shall be with one side planing, joint planed and two longitudinal edges prepared for lap joints of 12.5 mm on opposite sides.

3.2 The rubber wood to be supplied shall be seasoned as per IS 1141 - 1993, "SEASONING OF TIMBER - CODE OF PRACTICE".

3.3 The process for chemical preservative treatment shall be as per IS 401 - 2001, "PRESERVATION OF TIMBER - CODE OF PRACTICE".

3.4 For chemical treatment, the preservative chemicals used shall be Copper, Chrome, and Boron (CCB) composition.

3.5 DIMENSIONS AND ITS TOLERANCE:

3.5.1 Dimensions shall be as specified in Purchase Order.

3.5.2 The dimensional tolerance shall be as follows:

Length	: ± 10 mm
Width	: ± 4 mm
Thickness	: ± 3 mm for thickness up to 30 mm : ± 4 mm for thickness above 30 mm
Bow	: ± 4 mm per 300 mm

CBF113664



**SPECIFICATION FOR
PACKING WOOD -
RUBBER WOOD**

Doc. No. PR: CHEM: 20

Rev. No.: 03

Date: 15.11.2005

3.6 FREEDOM FROM DEFECTS:

3.6.1 Planks, Scantlings, Battens shall be free from defects like cracks, bends and knots.

3.7 The material shall also comply with the requirements given in Table - 1.

Table - 1 REQUIREMENTS FOR RUBBER WOOD

S. No.	Characteristics	Requirement
1	Species	Rubber
2	Chemical depth penetration Test	6.0 mm. (min)

CBF113664

20000 - 1 RD - HS - 2
CON DRAWING

B. S. FOR DETAIL DRG. PL. REFER
TOP - 2-SH-B-001/B.
BOTTOM - 2-SH-B-001 A/B.
SIDE - 2-SH-B-001 B/B.
END - 2-SH-B-001 C/B.

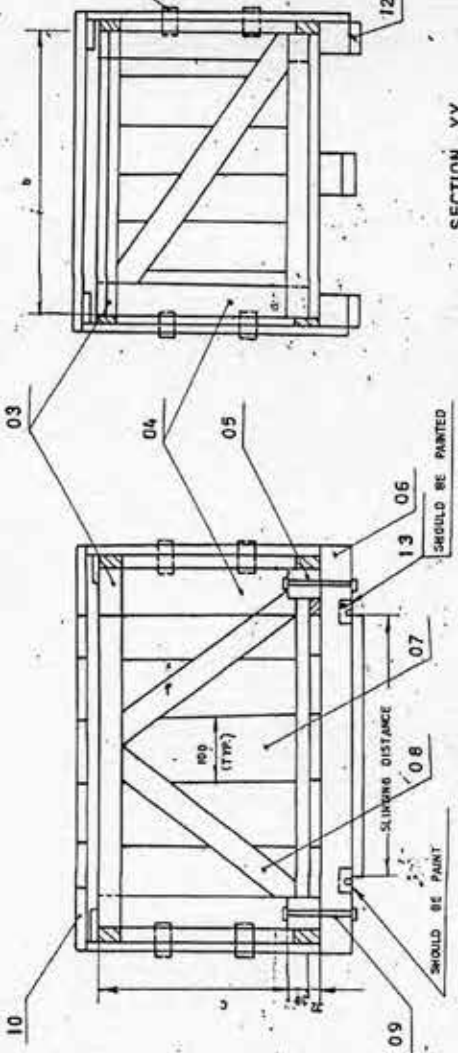

SECTION - XX

SECTION - YY

- NOTES:
1. END SHOOK IS TO BE FIXED WITH BASE 4 NAILS @ GAUGE.
 2. ALL OTHER MAILING SHOULD BE 2 1/2 - 10 GAUGE FOR ASSY.
 3. CORNER PLATE AND SLING PLATE IS TO BE FIXED WITH 2" NAILS 12 GAUGE.
 4. TYPE 966 BOX HAVE 2 RUNNERS IN THE BASE.

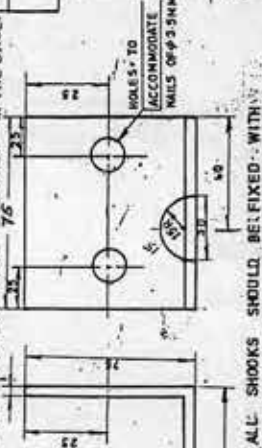

SECTION - YY

5. ALL SHOOKS SHOULD BELIEVED WITH POLYTHINE SHEET TO PROTECT FROM RAIN WATER

TYPE	a	b	c
1977	1500	700	700
1299	1300	900	900
1286	1200	900	600
966	900	600	600

15	SLINGING DISTANCE SHOULD BE PAINTED	880
14	CAPACITY KG	2000
13	SLING PL. 150 X 75 X 0.5 SHOULD BE PAINTED	4MS
12	RESTING BOARD	40 X 100
11	SID. PLATE SHOULD BE PAINTED X NAILS 2	F50K75X0.5
10	THICKNESS OF SHEATHING PLANK	150 X 25
09	BOLT SIZE	M 12 6 NOS
08	DIAGONAL BRACE	30 X 100
07	INTERMEDIATE VERTICAL SUPPORT	30 X 100
06	RUNNER	100 X 100 3 NOS
05	BASE END TRAVERSE BAR	70 X 70 3 NOS
04	LATERAL PANEL AND END PANEL VERTICAL SUPPORT	30 X 100
03	LATERAL PANEL AND END PANEL HORIZONTAL SUPPORT	30 X 100
01	TOP LONGITUDINAL BEAM	3 NOS. 30 X 100

TYPE OF PRODUCT
OS NAME OF ALL DIMENSIONS SHOWN FOR TV_1296 BOX

CUSTOMER/PROJECT

SHARAT HEAVY ELECTRICALS LTD.
ONE NEW PEARSON ROAD PLATE
THERMOMILLS-ROHINI

DATE: 12/11/2011
TIME: 11:00 AM
BY: P. B. N.
REF. TO ART/OLD Dwg.

SCALE

BOILER COMPONENT
PACKING BOX

SHAWING NO. 2-SH-CRT-00002 B

U 01

8 Size A2

B/V - 100-B-HS-2-
ON DRAWING

FOR TOLERANCES OF UNFINISHED
DIMENSIONS SEE THE MANUFACTURE
WORK PLANT DRAWING TO Q22 Q209

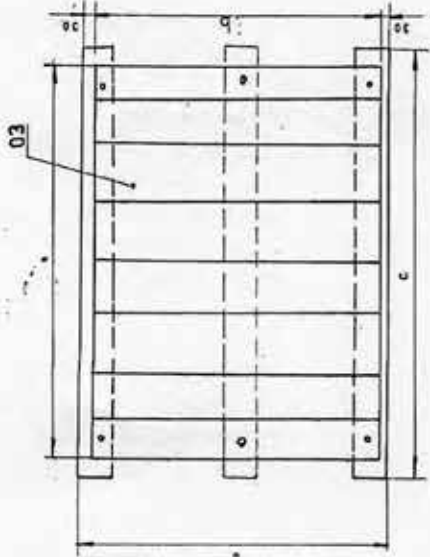
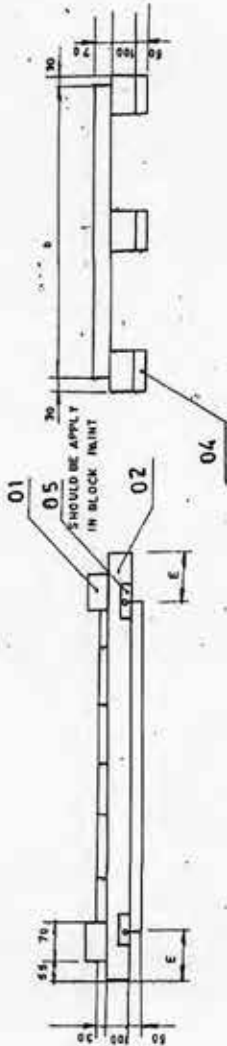

E	150-150	150-150	200-200	200-200
F	560	960	960	760
C	1010	1310	1610	1610
D	600	900	900	700
B	900	1200	1300	1500
ITEM NO.	TYPE	TYPE	TYPE	TYPE
	566	1236	1339	1577

04	BASE RESTING BOARD	710 X 100 X 50	1010 X 100 X 50	1010 X 100 X 50	710 X 100 X 50
03	BASE PLANKS	600 X 150 X 30	900 X 150 X 30	900 X 150 X 30	700 X 150 X 30
02	BASE RIBBON	1010 X 100 X 100	1310 X 100 X 100	1410 X 100 X 100	1010 X 100 X 100
01	BASE END TRAVES	600 X 70 X 70	900 X 70 X 70	900 X 70 X 70	700 X 70 X 70
ITEM NO.	DESCRIPTION	TYPE : 566	TYPE : 1236	TYPE : 1339	TYPE : 1577

TYPE OF PRODUCT OR NAME OF CUSTOMER/PRODUCT

Shorot Heavy Electrics Ltd
UNIT: HIGH PRESSURE BLOWER PLANT
TRUCKRAPALI - 620014

DATE: 15/01/81

REVISED: 01

DESIGNED BY: T. XAVIER

DRAWN BY: M. KALLARANTHI

CHECKED BY: P. SELLARAJIN

SCALE: 1:1

PROJECT NO: 2 SH B 001 A/B

TITLE: BASE SHOOK

DRIVING NO: 2 SH B 001 A/B

REV: 1

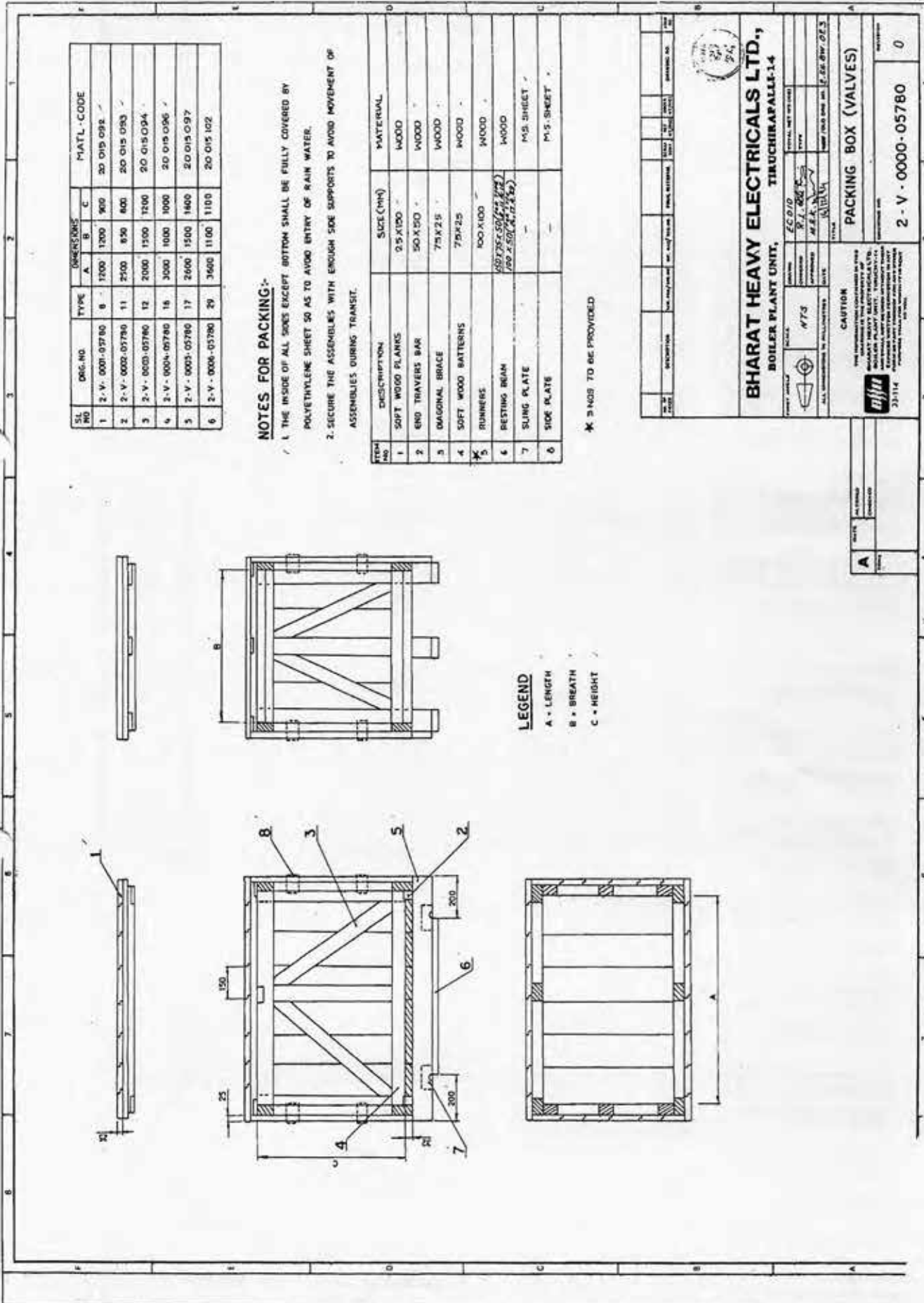

SL. NO.	DRG. NO.	TYPE	DIMENSIONS			MATL. CODE
			A	B	C	
1	2-V-0001-05780	8	1200	900	20	019.092
2	2-V-0002-05780	11	2500	950	800	20 019.093
3	2-V-0003-05780	12	2000	1500	1500	20 019.094
4	2-V-0004-05780	18	3000	1000	1000	20 019.096
5	2-V-0005-05780	17	2600	1500	1400	20 019.097
6	2-V-0006-05780	29	3600	1100	1100	20 019.102

NOTES FOR PACKING:-

1. THE INSIDE OF ALL SIDES EXCEPT BOTTOM SHALL BE FULLY COVERED BY POLYETHYLENE SHEET SO AS TO AVOID ENTRY OF RAIN WATER.
2. SECURE THE ASSEMBLIES WITH ENOUGH SIDE SUPPORTS TO AVOID MOVEMENT OF ASSEMBLIES DURING TRANSIT.

ITEM NO.	DESCRIPTION	SIZE (MM)	MATERIAL
1	SOFT WOOD PLANKS	2.5 X 100	WOOD
2	END TRAVERS BAR	50 X 50	WOOD
3	DIAGONAL BRACE	75 X 25	WOOD
4	SOFT WOOD BATTERNS	75 X 25	WOOD
5	RUNNERS	100 X 100	WOOD
6	RESTING BEAM	150 X 75 X 50 (2 Nos) 100 X 50 (2 Nos)	WOOD
7	SLING PLATE	-	M.S. SHEET
8	SIDE PLATE	-	M.S. SHEET

* 3 NOS TO BE PROVIDED

LEGEND

- A - LENGTH
- B - BREADTH
- C - HEIGHT

DATE	DESCRIPTION	REV. NO.	REV. DATE	REV. BY	REV. REASON

BHARAT HEAVY ELECTRICALS LTD.,
BOILER PLANT UNIT, TIRUCHIRAPALLI-14

PROJECT NO.	SCALE	TOTAL NET WEIGHT

APPROVED BY: *[Signature]*
DATE: *[Date]*

ALL DIMENSIONS IN MILLIMETERS

CAUTION
THE INFORMATION CONTAINED HEREIN IS UNCLASSIFIED EXCEPT WHERE SHOWN OTHERWISE. IT IS THE PROPERTY OF BHARAT HEAVY ELECTRICALS LTD. AND IS LOANED TO YOU. IT IS TO BE KEPT SECRET AND NOT TO BE REPRODUCED OR TRANSMITTED IN ANY FORM OR BY ANY MEANS, ELECTRONIC OR MECHANICAL, INCLUDING PHOTOCOPYING, RECORDING, OR BY ANY INFORMATION STORAGE AND RETRIEVAL SYSTEM.

PACKING BOX (VALVES)

2 - V - 0000 - 05780 0

TP-DC-2-V-0000-05779

SL NO	QTY	TYPE	DIMENSIONS			MATERIAL
			A	B	C	
1	2	2-V-0001-05779	670	670	570	20 015 020
2	2	2-V-0002-05779	710	630	600	20 015 080
3	2	2-V-0003-05779	850	630	670	20 015 081
4	2	2-V-0004-05779	1000	770	670	20 015 082
5	2	2-V-0005-05779	1100	430	670	—
6	2	2-V-0006-05779	1230	370	1100	20 015 083
7	2	2-V-0007-05779	1300	770	1050	20 015 084
8	2	2-V-0008-05779	1700	600	700	20 015 086
9	2	2-V-0009-05779	1850	1050	1250	20 015 085
10	2	2-V-0010-05779	2000	800	800	20 015 088
11	2	2-V-0011-05779	300	450	360	200 15 210

ITEM NO	DESCRIPTION	SIZE (MM)	MATERIAL
1	SOFT WOOD PLANKS	25 X 100	WOOD
2	END TRAVERS BAR	50 X 50	WOOD
3	DIAGONAL BRACE	75 X 25	WOOD
4	SOFT WOOD BATTERNS	75 X 25	WOOD
5	BUNNERS	75 X 25	WOOD
6	RESTING BEAM	150 X 75 X 50	WOOD
7	SICG PLATE	—	MR. SHEET
8	SIDE PLATE	—	MR. SHEET

NOTES FOR PACKING:

1. THE INSIDE OF ALL SIDES EXCEPT BOTTOM SHALL BE FULLY COVERED BY POLYETHYLENE SHEET SO AS TO AVOID ENTRY OF RAIN WATER.
2. SECURE THE ASSEMBLIES WITH ENOUGH SIDE SUPPORTS TO AVOID MOVEMENT OF ASSEMBLIES DURING TRANSIT.

LEGEND :-

- A - LENGTH
- B - BREADTH
- C - HEIGHT

BHARAT HEAVY ELECTRICALS LTD.,
BOILER PLANT UNIT, TIRUCHIRAPPALLI-14

CAUTION
DO NOT REMOVE THE CONTENTS OF THIS BOX WITHOUT THE PERMISSION OF THE SUPPLIER.

PACKING BOX (VALVES)

2 - V - 0000 - 05779

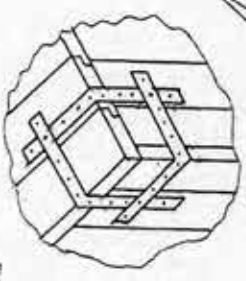

ITEM NO.	QTY	DESCRIPTION	UNIT	APPROX. WEIGHT TO BE CARRIED
296	2	BOX TYPE NR-51	850	850 Kg
297	2	BOX TYPE NR-22	950	1600 Kg
298	2	BOX TYPE NR-53	1120	650 Kg
299	2	BOX TYPE NR-54	2000	2000 Kg
300	2	BOX TYPE NR-55	1900	2000 Kg

ITEM NO.	TYPE	DIMENSIONS			APPROX. WEIGHT TO BE CARRIED
		L	W	H	
296	BOX TYPE NR-51	2775	850	850	850 Kg
297	BOX TYPE NR-22	2000	950	740	1600 Kg
298	BOX TYPE NR-53	1600	1120	700	650 Kg
299	BOX TYPE NR-54	2500	2000	1200	2000 Kg
300	BOX TYPE NR-55	2300	1900	1400	2000 Kg

- 001 TOP BOARD : 25 MM THICK.
- 002 BOTTOM BOARD : 25 MM THICK.
- 003 SIDE BOARD : 25 MM THICK.
- 004 END BOARD : 25 MM THICK.
- 005 END TRAVERSE BAR : 28 X 50
- 006 ALL SIDE RAFTERS : 100 X 25
- 007 ALL DIAGONAL BRACES : 100 X 25
- 008 RESTING BEAMS : 150 X 50
- 009 RUNNERS : 100 X 100
- 010 SUPPORTING : 150 X 50
- 011 SLING PLATE (MS SHEET)
- 012 SIDE PLATE (MS SHEET)
- * ALL DIMENSIONS SHOULD BE OF QUALITY WOOD.

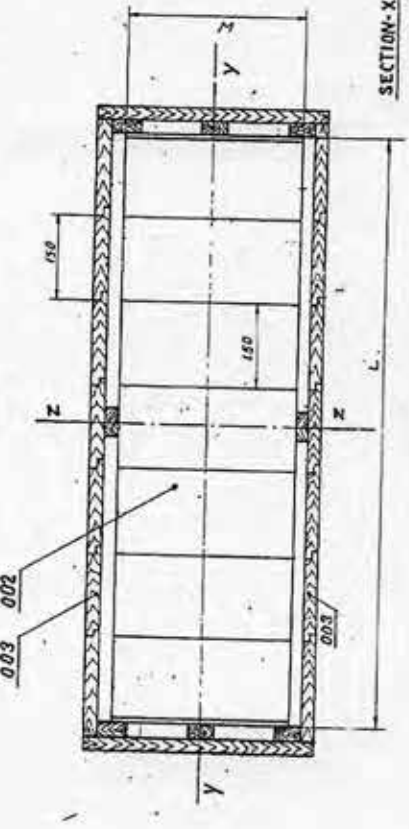
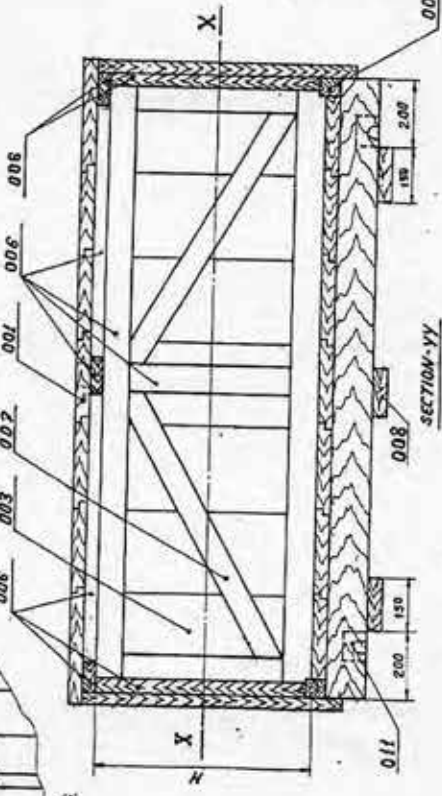
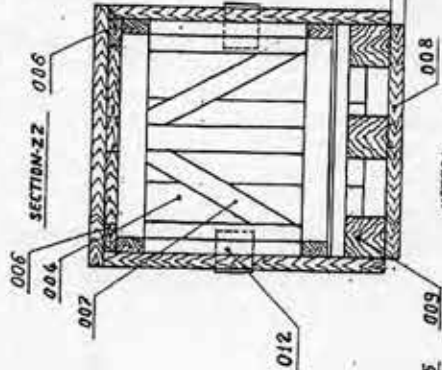

MF 10571082

- NOTES:-
1. THE INSIDE OF ALL SIDES EXCEPT BOTTOM AND TOP SIDE SHALL BE FULLY COVERED BY A SINGLE BUTYRISED PAPER AND SUITABLY FINED. THE INSIDE OF TOP SIDE SHALL BE FINED WITH BUTYRISED PAPER AND POLYETHYLENE SHEET. THE POLYETHYLENE SHEET SHALL BE PROJECTING 50 MM ON ALL SIDES. AFTER PUTTING THE TOP BAR CLOSING THE CASE, THE PROJECTING POLYETHYLENE SHALL BE SUITABLY TACKLED INSIDE SBAS TO AVOID DIRECT ACCESS OF WATER FROM THE TOP OF THE CASE.
 2. TO INDICATE TOP SIDE OF BOX PAINT SUITABLY BY MARKING (PREFERABLY BY UNDERCELL MARKING "C.C.") ON ALL SIDES OF THE BOX.
 3. CORNER STAMPING SHALL BE DONE ON ALL CORNERS. STRAPS SHALL NOT BE LESS THAN 50MM WIDE AND 6.25MM THICK. STRAPS MAY BE PNE PUNCHED OR DRILLED.
 4. THE NUMBER AND WIDTH OF THE SIDE AND END BEARDS SHALL BE DECIDED DEPENDING UPON THE HEIGHTS.
 5. COMPONENTS LIKE STOP, TUBING HANDBS, FASTENERS, RJ GAUGES, M. GAUGES, ETC ARE TO BE PACKED SEPARATELY IN A BOX AND PLACED IN-SIDE THE MAIN BOX.
 6. SECURE THE ASSEMBLY WITH ENOUGH SIDE SUPPORTS TO AVOID MOVEMENTS OF ASSEMBLY DURING TRANSPORT AND ALSO SECURE SUITABLY TO AVOID VERTICAL MOVEMENT.

BHARAT HEAVY ELECTRICALS LTD.,
BOILER PLANT UNIT, TRICHIRAPPALLI-14

PROJECT NO. 14-1000-111000
DRAWING NO. 14-1000-111000-001

SCALE: 1:100

DATE: 28.4.86

DESIGNED BY: [Signature]
CHECKED BY: [Signature]
APPROVED BY: [Signature]

ALL DIMENSIONS IN MILLIMETERS

CAUTION
THE INFORMATION CONTAINED HEREIN IS THE PROPERTY OF BHARAT HEAVY ELECTRICALS LTD., TRICHIRAPPALLI. IT IS TO BE USED ONLY FOR THE PROJECT AND BOX PLANT UNIT, TRICHIRAPPALLI. IT IS NOT TO BE REPRODUCED OR TRANSMITTED IN ANY FORM OR BY ANY MEANS, ELECTRONIC OR MECHANICAL, INCLUDING PHOTOCOPYING, RECORDING, OR BY ANY INFORMATION STORAGE AND RETRIEVAL SYSTEM.

30-114

REV	DATE	DESCRIPTION
01	28.4.86	INITIAL DESIGN
02	28.4.86	REVISED DESIGN
03	28.4.86	REVISED DESIGN
04	28.4.86	REVISED DESIGN
05	28.4.86	REVISED DESIGN
06	28.4.86	REVISED DESIGN
07	28.4.86	REVISED DESIGN
08	28.4.86	REVISED DESIGN
09	28.4.86	REVISED DESIGN

FIRST ANGLE PROJECTION (ALL DIMENSIONS IN MILLIMETRES)

DATE: 2.V.7503.10122
DRAWING NO.

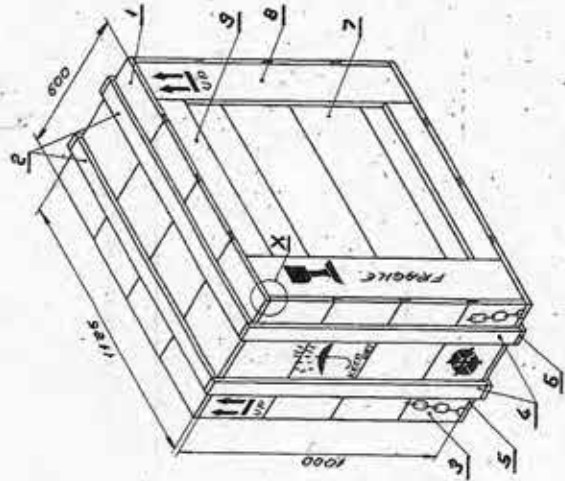
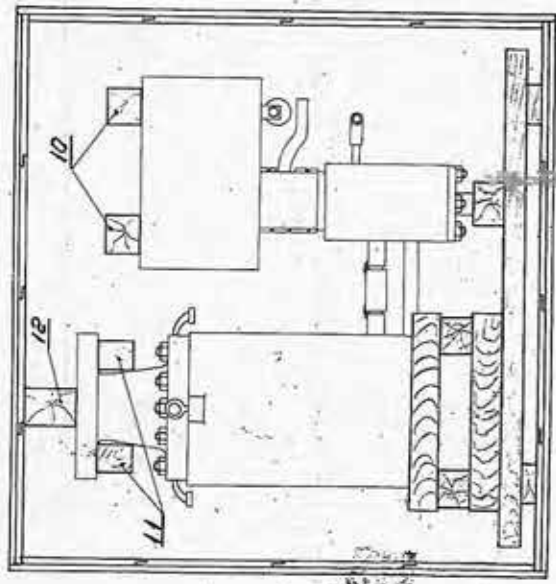

NOTES:

1. THE INSIDE OF ALL SIDES EXCEPT BOTTOM & TOP SIDE SHALL BE FULLY COVERED BY A SINGLE SUPPLEMENTED BARRIER AND SUITABLY FIRED. THE INSIDE OF TOP SIDE SHALL BE FIRED WITH SUPPLEMENTED BARRIER AND POLY ETHYLENE SHEET. THE POLY ETHYLENE SHEET SHALL BE PROTECTING 50MM ON ALL SIDES. AFTER PUTTING THE TOP FOR CLOSING THE CASE, THE PROTECTING POLY ETHYLENE SHALL BE SUITABLY TACKLED INSIDE SO AS TO PREVENT DIRECT ACCESS OF WATER FROM THE TOP OF THE CASE.
2. THE TACKLE ALONG WITH CRADLE ASSEMBLY SHALL BE COVERED BY A POLY ETHYLENE SHEET AND THEN PLACED INSIDE THE BOX.
3. BARRIT MANNINGS AS SHOWN IN 3RD ON ALL SIDES OF BOX.
4. WOOD MATERIALS SHALL BE AS HIGH CLASS ORIGIN ON 19.1503-1983
5. CORNER STRENGTHENING SHALL BE USED ON ALL CORNERS. STRENGTHENING SHALL NOT BE LESS THAN 20MM HIGH AND 0.8MM THICK. STRENGTHENING SHALL BE MATCHED ON ALL SIDES.

This drawing is pertaining
TO TYPE 62 BOX

Ug-101
K. Rathinakar
Senior Manager
MM/Specialty Dept. & CNS
MIDEL, Thiruvananthapuram

1. TOP BOARD - 25 THICK
 2. TOP GIRTH BATTENS - 25 WIDTH X 60 THICK (EQUALLY SPACED)
 3. SIDE BOARD - 25 THICK
 4. SIDE GIRTH BATTENS - 25 WIDTH X 60 THICK
 5. BOTTOM BOARD - 25 THICK
 6. BOTTOM GIRTH BATTENS - 25 WIDTH X 60 THICK
 7. END BOARD - 25 THICK
 8. END VERTICAL BATTENS - 25 WIDTH X 60 THICK
 9. END HORIZONTAL BATTENS - 25 WIDTH X 60 THICK
 10. PLANK SIZE 25 X 25 X 620
 11. PLANK SIZE 20 X 25 X 620
 12. PLANK SIZE 20 X 180 X 620
- NOTE: THE NUMBER AND WIDTH OF THE SIDE & END BOARDS BE DECIDED DEPENDS UPON THE HEIGHT

DETAIL - X

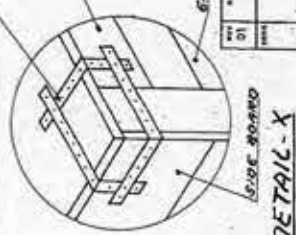

Bharat Heavy Electricals Ltd., BOLAR PLANT UNIT THIRUCHIRAPPALLI-620 014		E. P. LEON V. JAYARAMAN T. ARUNAVAR	
DRAWING NO. 3.V.7503-104-63		REVISION NO. 2-K-2503	
DATE 19.15.03		SCALE 1:1	
PROJECT NO. 3.V.7503-104-63		DRAWING CRADLE 300	

B/400-B-HS-E

02 100MM X 30MM

01 150MM X 25MM



TOP & BASE
(2 NOS.)

DETAILS OF ALL SIDES PROTECTION INTERNAL

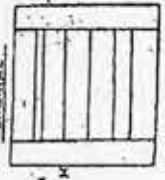

150MM X 25MM

ENDS
(2 NOS.)

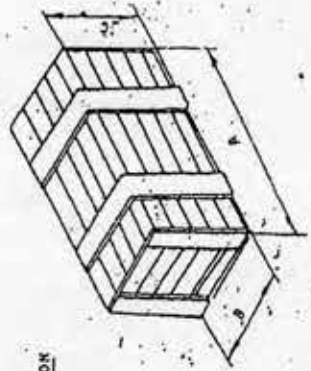

SIDES
(2 NOS.)

TYPE NO.	DIMES (MM)		
	A	B	C
1144	1100	400	500
1122	1100	200	200
634	600	500	400
633	600	300	300
1133	1100	300	300
1135	1100	500	500

ITEM NO.	DESCRIPTION	DRAWING NO.
03	NAILS	2 1/2 - 106
02	BATONS	100 X 30
01	PLANKS	25 X 150

TYPE OF PRODUCT TYPE 1144 1100 X 400 X 400MM
 OR NAME OF 1122 1100 X 200 X 200 MM
 CUSTOMER/PROJECT 634 600 X 500 X 400 MM
 633 600 X 300 X 300 MM

BHARAT HEAVY ELECTRICALS LTD.
 (INCORPORATED IN INDIA)
 100, T. K. ROAD, CHENNAI 600 004

DATE: 10/10/70
 BY: [Signature]
 CHECKED: [Signature]
 APPROVED: [Signature]

WEIGHT (KG) 1100
 SCALE 1:1

CARD CODE U 01
 DRAWING NO. 3-SH-B-004/B
 ART 01



DRAWING NO. 3-SH-B-004/C

DETAIL OF ALL SIZES PRODUCTION MATERIALS

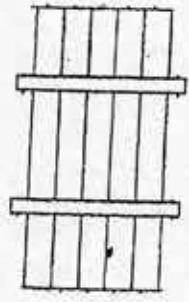
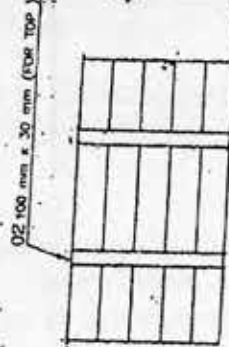
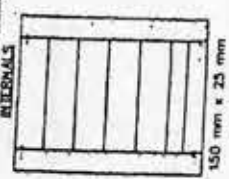

PRINTED BY
ORIGIN: GREEN COLOUR

TYPE No.	DIMENS. (mm)		
	A	B	C
654	600	500	400
10103	1050	1050	500

ITEM NUMBER	DESCRIPTION	DRAWING NUMBER	UNIT	QUANTITY
03.	NAILS 2 1/2" - 10 C			
02.	BATTENS 100 x 30			
01.	BLANKS 25 x 150			

TYPE OF PRODUCT: 654
OR NAME OF CUSTOMER/PROJECT: 10103

Bharat Heavy Electricals Ltd
UNIT, HIGH PRESSURE BOILER PLANT
TRICHIRAPALLI - 620014

TYPE OF PRODUCT: 1050 x 1050 x 500

REV. DATE: 01/01/84
ALTERED BY: CSD & APVC

BOILER COMPONENT PACKING BOXES

DRAWING NO.: 3-SH-B-004/C

5 36

000-B-HS-C
ON DRAWING

DETAIL OF ALL SIDES PROJECTION
INTERNAL

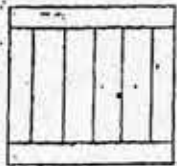

150 mm x 25 mm
ENDS
2 Nos.

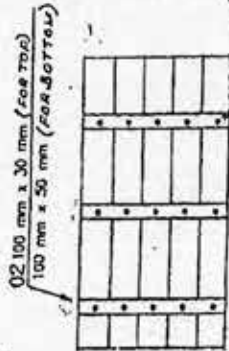

TOP & BASE
2 Nos.

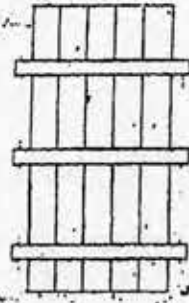

SIDES
2 Nos.

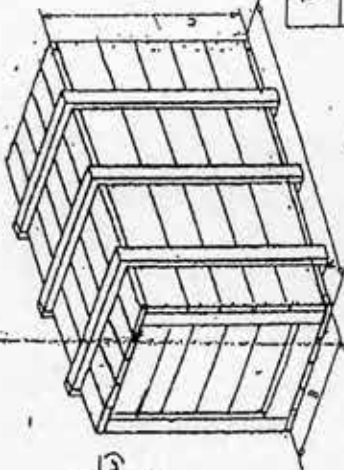

TYPE No.	* DIMENS. (mm)		
	A	B	C
18910	1600	900	1000

NO.	DESCRIPTION	UNIT	QUANTITY
03.	NAILS 2 1/2" - 3 1/2"		
02.	BATTENS 100 x 30 / 100 x 50		
01.	BLANKS 25 x 150		

TYPE OF PRODUCT: TYPE 18910 - 1600 x 900 x 1000
OR NAME OF CUSTOMER/PROJECT

Bohart Heavy Electricals Ltd
UNIT, HIGH PRESSURE BOILER PLANT
THURUPPALLI - 520014

TYPE: 000-B-HS-C

REV: 01

DATE: 23/4

ALIGNED: CHD & JAWD

DR: 3/4

SCALE: 1:1

PROJECTION: 1ST ANGLE

UNIT: 100 mm

MOQ: 100

NO. TO SET / NO. INC: 1

BOILER COMPONENT
BUTTON BOXES

DRAWING NO.: 3-SH-B-005

REV: 01

PRINTED BY
G

REV	DATE	ALTERED	SVJ
01	17-06-96	CHECKED	<i>[Signature]</i>

ALL DIMENSIONS ARE IN MILLIMETRES

DIMENSIONS CHANGED

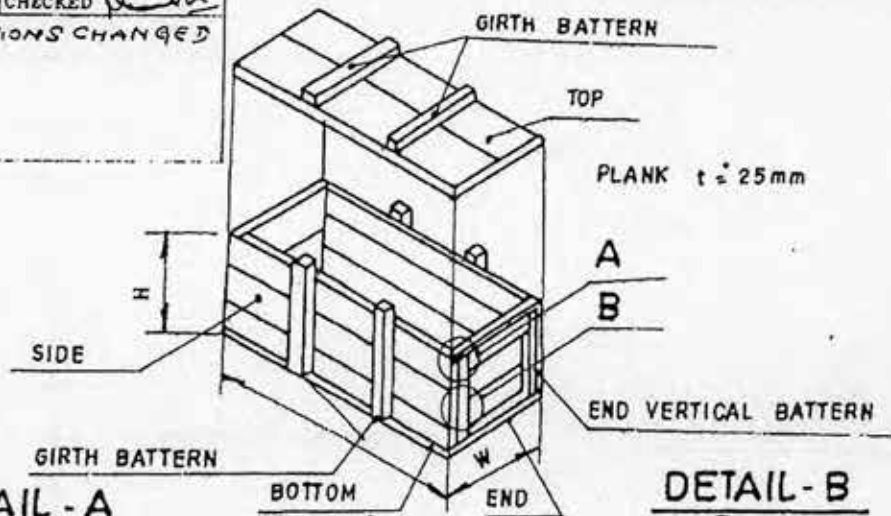

DETAIL - A

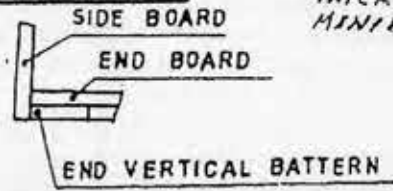

DETAIL - B

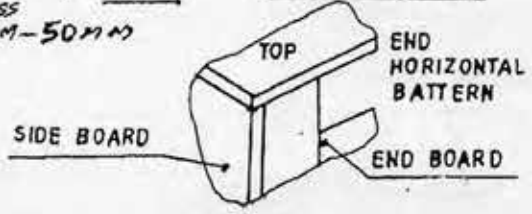

BOTTOM THICKNESS MINIMUM - 50MM

CAUTION: The information on this document is the property of BHARAT HEAVY ELECTRICALS LTD. It must not be used directly or indirectly in any way detrimental to the interest of the company

NOTES:

1. L X W X H ARE INNER DIMNS. OF THE BOX.
2. GIRTH BATTERNS:- ADDL. 2 NOS. FOR BOXES EXCEEDING LENGTH 1000mm & UPTO 2000mm.
3. GIRTH BATTERNS: ADDL. 3 NOS. FOR BOXES EXCEEDING 2000MM LENGTH.
4. BOTTOM RUNNER MINIMUM THICKNESS - 50MM
5. MINIMUM WIDTH OF PLANK - 200 EACH ONLY

TYPE NO.	INTERNAL DIMMS.			BATTERNS	MAX. NO. OF PLANKS EACH SIDE
	L	W	H		
SPF	320	250	260	75 X 25	2
SPG	320	250	430	75 X 25	2
SPH	430	370	430	75 X 25	2
SPI	1100	400	400	100 X 25	2
SPJ	1500	500	400	150 X 25	2
SPK	2000	500	400	150 X 25	2
SPL	2500	400	400	150 X 25	2
SPM	1600	450	450	150 X 30	2
SPN	3000	400	400	150 X 30	2
SPD	2800	600	500	150 X 30	3

	BHARAT HEAVY ELECTRICALS LTD. UNIT: HIGH PRESSURE BOILER PLANT, TIRUCHIRAPALLI 620014.		DRN NAME MDCO SERVE	SIGN <i>[Signature]</i>	DATE 10-06-95	NO. OF VAR
			CHD DJAYABALAM	SIGN <i>[Signature]</i>	DATE 10-06-95	
			APPD P.P. SELVAN	SIGN <i>[Signature]</i>	DATE 10-06-95	
DEPT CODE	GRADE OF UNTOL DIM C / M / F	SCALE 1:1	WEIGHT (KG)	REF. TO ASSY. OLD DRG. 4V-4000-07183	ITEM NO.	NO. OF ITEM
TITLE WOODEN BOX		APPROVED <i>[Signature]</i> 23/4/03 SM/SHIPPING/SB	CARD CODE U 01	DRAWING NO. 40-SPM-SH-00002	REV 01	

Size A4

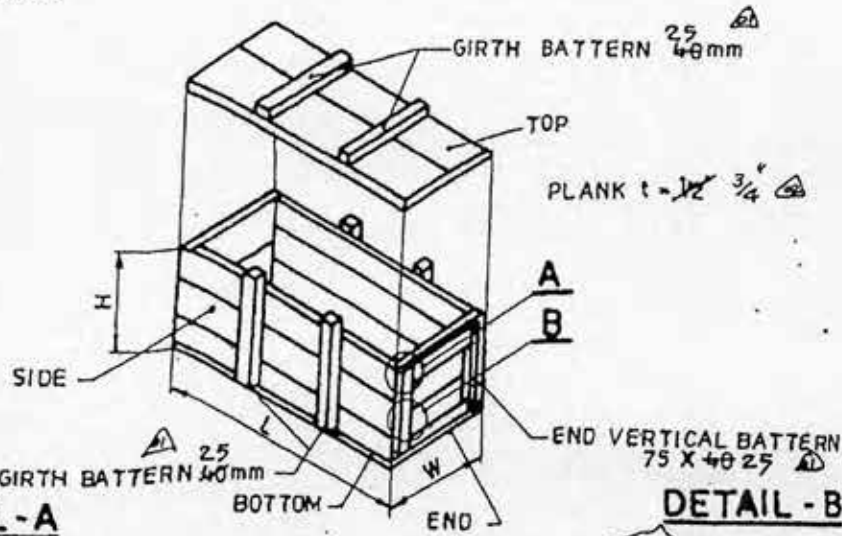

DETAIL - A

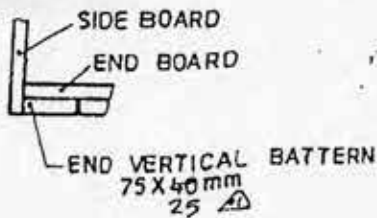

DETAIL - B

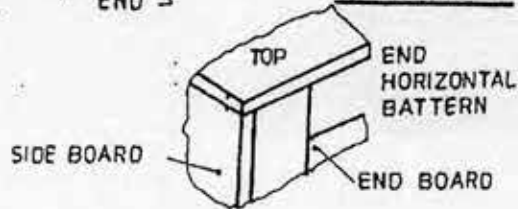

TYPE NO.	L	W	H	WEIGHT	
				NET WT (kg)	GROSS WT (kg)
1A	320	250	260		
1	320	250	430		
2	430	370	430		

NOTES:-

1. ALL DIMENSIONS ARE IN MM.
2. L, W, H ARE INNER DIMENSIONS OF THE BOX.
3. FOR TYPE NO 1A & 1 END VERTICAL BATTERN SHALL BE FLUSH ON BOTH ENDS WITH HARD BOARD TO WRITE THE DESPATCH DETAILS.



NO. OF PIECES	NAME - DIMENSIONS	SEMI-PRODUCT	FINAL MATERIAL	INITIAL MATERIAL	GROUP	NET WT (kg)	GROSS WT (kg)	DRAWING NO.	TYPE NO.
REMARKS				TOTAL NET WT (kg)					
SCALE	DRAWN	K.N. R. NATRAJAN 24/10/92			ALTERNATIONS	DATE	APPROVED	ALTERED	
	CHECKED	K.S.S. 24/10/92			100mm to 25 mm	26.9.94			
	APPROVED	D.K. P. 26.10.92			PLANK 30 mm x 25 mm	01.12.95			
	STN. OFFICER				NOTE 2 ADDED.				
	DATE								
TYPE		GROUP		OLD DRG.		NEW DRG.			
TITLE				DRAWING NO.					
WOODEN PACKING CASE				4-V-4000-07183		2			



INCORPORATE DRG ID

TABLE - 1

DETAILS OF wooden BOX DIMENSION, WEIGHT AND VOLUME								
BOX TYPE	BOX WT (KG)	INSIDE DIMENSION IN MM			OUTSIDE DIMENSION IN MM			VOLUM IN CUBIC METER
		LENGTH	BREADTH	HEIGHT	LENGTH	BREADTH	HEIGHT	
1A	10	320	250	260	450	300	280	0.038
1	15	320	250	430	450	370	580	0.097
2	25	430	370	430	570	490	590	0.165
3	65	670	670	470	770	770	700	0.415
4	75	710	830	600	810	730	840	0.497
5	95	850	630	670	960	730	900	0.624
6	100	1000	770	670	1100	870	915	0.876
7	80	1100	430	670	1200	520	900	0.562
8	170	1200	1200	800	1300	1300	1150	1.944
10	155	1300	770	1050	1400	880	1320	1.589
11	225	2600	850	800	2600	950	1050	2.594
12	305	2000	1500	1200	2100	1600	1400	4.704
14	260	1850	1050	1250	1950	1150	1480	3.319
15	180	2000	800	800	2100	900	990	1.871
16	345	3000	1050	1000	3100	1220	1250	4.728
17	470	2600	1500	1600	2700	1600	1830	7.906
29	390	3600	1100	1100	3700	1220	1350	6.094
21	25	250	250	600	380	380	770	0.111
22	30	250	250	880	380	380	1040	0.150
23	25	300	300	700	425	425	850	0.154
24	45	380	380	880	510	510	1050	0.273
27	80	570	570	1400	700	700	1560	0.764
28	105	575	675	1875	710	710	2040	1.028
62	130	600	1125	1000	700	1325	1200	1.113
63	55	800	370	750	900	500	800	0.360
51	260	2775	850	680	2870	950	950	2.590
52	255	2000	950	740	2100	1050	1050	2.315
53	220	1600	1120	700	1700	1220	980	2.033
54	490	2500	1900	1200	2600	2000	1450	7.540
55	525	2900	1900	1400	3000	2000	1650	9.900
56	370	3000	1000	900	3100	1100	1200	4.092
57	450	3200	2200	850	3300	2300	1100	8.349
58	325	2200	1100	750	2300	1200	1050	2.898
60	485	2300	2200	1200	2350	2300	1500	8.108
61		675		2000				

304 MM = 1 FEET

SUPPLIER'S LOGO

TEST CERTIFICATE FOR RUBBER WOOD (Model Format)

TEST REPORT No.:XXXX / Dated dd-mm-yy

DC No.:XXX/ Dated dd-mm-yy

1	NAME OF THE FIRM	
2	PO No.& DATE	
3	NAME OF CUSTOMER	BHEL, TRICHY
4	MATERIALS	CHEMICALLY TREATED RUBBER WOOD
5	QUANTITY & SIZE DETAILS	AS PER DC No. XXX / Dated dd-mm-yy
6	SPECN TO WHICH MATERIALS SUPPLIED	PR:CHEM: 20/03
	DIMENSIONAL REPORT	AS SPECIFIED IN PR: CHEM: 20/03, Cl. 3.5
8	NAME OF THE SPECIES IDENTIFIED (TRADE NAME)	RUBBER WOOD
9	DATE OF SEASONING / TYPE OF SEASONING	dd-mm-yy / Kiln Seasoning
10	PERCENTAGE OF MOISTURE CONTENT IN SEASONED WOOD BEFORE CHEMICAL TREATMENT (Test as per IS:401, Annex C)	XX %
11	DATE OF CHEMICAL TREATMENT	
12	TYPE OF CHEMICAL TREATMENT FOLLOWED	PRESSURE TYPE / VACUUM IMPREGNATION (Tick as applicable)
13	TYPE OF CHEMICAL PRESERVATIVES USED	Copper - Chromium - Boron (C.C.B)
	DEPTH OF PENETRATION OF PRESERVATIVE CHEMICALS, mm	___ mm (As per PR: CHEM: 20/03, Cl 3.7)
	Presence of Copper (Test as per IS:401, Annex D)	Present
	Presence of Chromium (Test as per IS:401, Annex D)	Present
	Presence of Boron (Test as per IS:401, Annex D)	Present
15	PERCENTAGE OF MOISTURE CONTENT AFTER CHEMICAL TREATMENT (Test as per IS:401, Annex C)	xx% (WHEN DISPATCHED)
16	Certified that the above supply conforms to the specification. PR: CHEM: 20 / 03.	

SIGNATURE OF QUALITY INSPECTOR WITH SEAL