

DRG.NO. 2-61-100-90116

INVENTORY NO. 26190116.DWG THE INFORMATION ON THIS DOCUMENT IS THE PROPERTY OF BHARAT HEAVY ELECTRICALS LIMITED. IT MUST NOT BE USED DIRECTLY OR INDIRECTLY IN ANY WAY DETRIMENTAL TO THE INTEREST OF THE COMPANY.

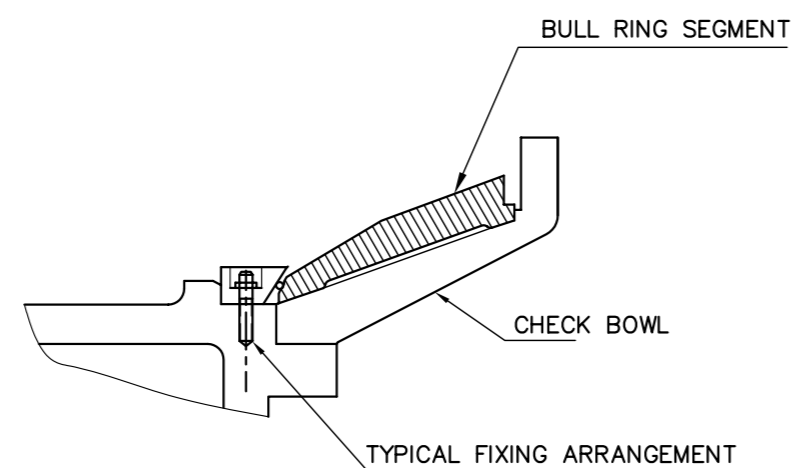

SECTION - AA

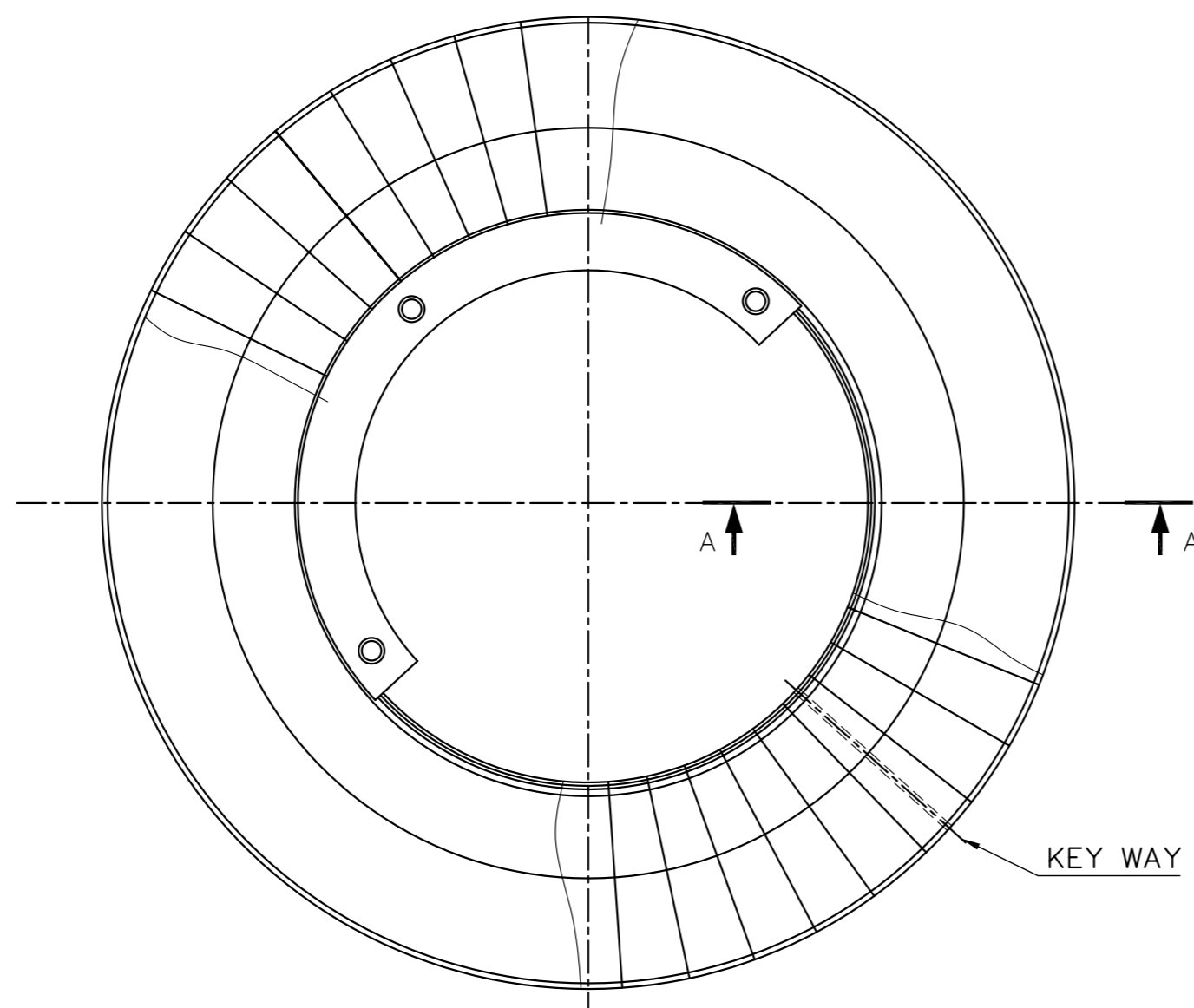

ONE SET OF BULL RING ASSEMBLY ON CHECK BOWL CONSISTS OF

SEGMENT TYPE	DRAWING NO.	QTY.REQD.
KEY WAY	2-61-100-90114	1
PLAIN	2-61-100-90113	44±1
QUARTER	2-61-100-90115	AS REQUIRED TO ACHIEVE LESS THAN 21 mm GAP.
SHIM SET	3-61-100-90151 VARIANT 01 OR 02	ONE PIECE ONLY IN ASSY

ACCEPTANCE CRITERION ON CHECK BOWL

- GAP BETWEEN THE FIRST AND THE LAST SEGMENT SHALL BE LESS THAN 21 MM BEFORE SHIM FITTING.
- USE REQUIRED QUANTITY OF QUARTER SEGMENTS TO ACHIEVE THIS.
- USE REQUIRED QTY OF SHIMS (3.15,6, 12) TO FILL THE GAP AT SITE.

ITEM NO	DESCRIPTION	DRAWING NO.	VAR. NO.	RAW MATERIAL SIZE OR CASTING DRG.NO. OR FORGING DRG.NO.	MATERIAL CODE	NET WT.	GROSS WT.
06	BULL RING SEG. QUARTER	2-61-100-90115			HY19772	8.50	
05	SHIM BULL RING ASSY. 12 mm	3-61-100-90151	03		AA1011819090 AA10119	2.7 2	
04	SHIM BULL RING ASSY. 6 mm	3-61-100-90151	02		AA1011808030 AA10108	1.35 1	
03	SHIM BULL RING ASSY. 3.15 mm	3-61-100-90151	01		AA1011711133 AA10111	0.71 1	
02	BULL RING KEYED SEGMENT	2-61-100-90114			HY19770	33.00 1	
01	BULL RING SEG. MENT. PLAIN	2-61-100-90113			HY19770	33.80 44	
					MATERIAL SPECN.	QUANTITY	

- TOTAL WEIGHT INDICATED IS WITHOUT SHIMS
- INSTALL SHIM APPROXIMATELY 180° FROM KEY WAY SEGMENT
- FOLLOWING ADDITIONAL SHIM SET TO BE SHIPPED ALONG WITH CORRESPONDING BULL RING ASSY.

3.15 mm (1) ONE AS PER VARIANT 01 OF DRG No. 3-61-100-90151
 6mm (1) ONE PER VARIANT 02 OF DRG No. 3-61-100-90151
 12mm (2) TWO AS PER VARIANT 03 OF DRG No. 3-61-100-90151

SHIM SET TO BE SECURELY WRAPPED OR WIRED AND MARKED WITH THICKNESS VAR No.& DRG. No.

REV.	DATE	ALTERED	REV.	DATE	ALTERED	REV.	DATE	ALTERED	REV.	DATE	ALTERED
05	26.12.11	CHECKED [Signature] APPD [Signature]	04	16.07.02	CHECKED [Signature] APPD [Signature]	03	27.6.96	CHECKED [Signature] APPD [Signature]	02	22.9.94	CHECKED [Signature] APPD [Signature]
ZONE	ACCEPTANCE CRITERION ON CHECK BOWL MODIFIED AND NOTES 3 & 4 DELETED.		ZONE	ACCEPTANCE CRITERION ON CHECK BOWL ADDED. DRG REDRAWN. NOTES AMENDED. BOM CORRECTED.		ZONE	ITEM NO 2 WT WAS 26 KGS. TOTAL WT WAS 1513 KGS. WT CHANGED AS PER HY/FDY/TECH/96 DT 15.6.96		ZONE	ITEM NO 6 AND NOTE 5 ADDED.	
	1		2			3			4		

THE FOLLOWING CONDITIONS APPLY EXCEPT OTHERWISE STATED...

- REF. TO HY0230261 FOR UNSPECIFIED TOLERANCES.
- CHAMFER M/CD SHARP EDGES 1.2 TO 1.0 AT 45°.
- INTERNAL M/CD CORNER RADII 1 TO 0.7.
- THE SURFACE ROUGHNESS WHEREVER NOT SHOWN SHALL BE TAKEN FROM THE SURFACE ROUGHNESS SHOWN OUT SIDE BACK SLASHES GIVEN AT THE TOP MOST RIGHT CORNER OF THE DRG.

TYPE OF PRODUCT OR NAME OF CUSTOMER/PROJECT: XRP 1003 BOWL MILL

DRN.	NAME	SIGN	DATE	NO.OF VAR.
E.M.ASHOK			30.5.02	
N.D.S			30.5.02	
S.G			30.5.02	

DEPT.	PULV/ENGG	SCALE	N.T.S	WEIGHT(Kg)	1538.00	REF. TO ASSY DRG.	ITEM NO.	NO.OF ITEMS
CODE	446							
TITLE	BULL RING ASSY.			DRAWING NO.	2-61-100-90116		REV.	05
				SHEET NO.	NO OF SHEETS			