



BHARAT HEAVY ELECTRICALS LIMITED

(A Government of India Undertaking)
HIGH PRESSURE BOILER PLANT
PURCHASE DEPARTMENT - FOSSIL BOILERS
THIRUCHIRAPALLI - 620014
TAMILNADU (INDIA)

Page
1/2

PHONE :2577629
GRAMS : BHARATELEC
FAX NO: 2520719
E-mail: srchandran@bheltry.co.in
Web:

429-002/A

Enquiry No	Enquiry Date	Due Date for Quotation
2611400120 - 71	10.10.2014	03.11.2014

Please quote Enquiry No, Date and due date in all correspondences.
This is only a request for quotation and not an order

Item	Description	Unit	Quantity	Delivery Quantity	Schedule Date
10	560040011000 Electrode Holder (Fully insulated) for rated current 400 amperes at 35 % Duty Cycle.Electrode holder as per EN 60974-11:2010. Technical Details and delivery schedule as per Technical Annexure (Annexure - I)	NO	2000.000	2,000.00	30.03.15
20	560040012000 ELECTRODE HOLDER ASSY.(MODIFIED)400 Amperes(FULLY INSULATED). AS PER DRG.NO.3M-10A43-12947 TO 12950 AND AS PER DRG.NO.4M-10A43-28059 TO 28064. First Delivery Schedule - 400 numbers Within 60 Days after receipt of Purchase Order. Second Delivery Schedule -Balance quantities Within 115 Days after receipt of Purchase Order.	NO	800.000	800.00	31.03.15

General Note:

1. POINT-BY-POINT CONFIRMATION TO BHEL'S SPECIFICATIONS, COMMERCIAL TERMS & CONDITIONS ARE TO BE PROVIDED BY THE VENDORS IN "ANNEXURE A&B & ANNEXURE-I.

2. PLEASE ENSURE THAT ALL DULY FILLED ANNEXURES ARE ATTACHED WITH THE TECHNO-COMMERCIAL BID POSITIVELY. OTHERWISE YOUR OFFER IS LIABLE FOR REJECTION.

3. VALIDITY OF THE OFFER SHOULD NOT BE LESS THAN 120 DAYS. OTHERWISE YOUR OFFER SHALL BE LIABLE FOR REJECTION

4. The bidder may also be a Micro and Small Enterprises (MSE) vendor registered as per MSE act. As per the public procurement policy notified by the Central government,

20% of the tendered quantity is earmarked for MSE suppliers in this tender.

Out of the 20% tendered quantity reserved for MSE suppliers, 4% shall be

The offers should reach us 30 minutes before the time of opening of tenders.
The offers will be opened at 14.30 hrs on the due date of tender in the presence of tenderers who have submitted their offer and who may like to be present for the tender opening.Late and delayed offers are liable to be rejected.

Yours faithfully,
For BHARAT HEAVY ELECTRICALS LIMITED

MANAGER / PURCHASE
(FOSSIL BOILERS)
Yours faithfully,



BHARAT HEAVY ELECTRICALS LIMITED

(A Government of India Undertaking)
HIGH PRESSURE BOILER PLANT
PURCHASE DEPARTMENT - FOSSIL BOILERS
THIRUCHIRAPALLI - 620014
TAMILNADU (INDIA)

PHONE :2577629
GRAMS : BHARATELEC
FAX NO: 2520719
E-mail: srchandran@bheltry.co.in
Web:

Page
2/2

2611400120 / 10.10.2014

earmarked for procurement from MSE owned by SC / ST entrepreneurs.
 In case MSE vendor participating in the tender quotes within the price band of L1 + 15%, they will be allowed to supply the portion of the requirement subject to acceptance of L1 price by MSE vendor. In case of more than one such MSE, the supply shall be shared proportionately. MSE suppliers can avail the intended benefits only if they submit along with offer, attested copies of either EM II certificate having deemed validity (Two years from the date of issue of acknowledgement in EM II) or valid NSIC certificate or EM II certificate along with CA certificate (Format enclosed Annexure - V) applicable for the year, certifying quantum of investment in plant and machinery within the permissible limit as per the act for relevant status (Micro or small) where the deemed validity of EM II is over. Date to be reckoned for determining the deemed validity will be the last date of technical bid submission. Offer/s received without these documents will lead to consideration of their offer at par with other bidders and MSE status of such suppliers shall be shifted to Non MSE supplier. Documents submitted after technical bid opening will not be considered in the tender.

If the vendor is MSE vendor, kindly inform us (Ready refrence given as per annexure-iv.)

5. The order will be placed/done on individual item L1 basis ONLY, not on the whole package L1 BASIS.

LIST OF ATTACHMENTS:

1. ANNEXURE-I : TECHNICAL ANNEXURE
2. ANNEXURE-II TERMS AND CONDITIONS OF THE ENQUIRY. (TWO PART-BID)
3. ANNEXURE-A CHECK LIST FOR COMMERCIAL TERMS CONFIRMATION-TO BE FILLED BY THE SUPPLIER.
4. ANNEXURE-B MODEL PRICE BID FORMAT.
5. ANNEXURE-IV :CA certificate format to be furnished as per MSMED act 2006, if applicable (For MSME vendors)
6. ANNEXURE-VI CHECK LIST TO BE SUBMITTED ALONG WITH OFFER

Enclosures:

"LD clause has to be confirmed without fail."

The offers should reach us 30 minutes before the time of opening of tenders. The offers will be opened at 14.30 hrs on the due date of tender in the presence of tenderers who have submitted their offer and who may like to be present for the tender opening. Late and delayed offers are liable to be rejected.

Yours faithfully,
For **BHARAT HEAVY ELECTRICALS LIMITED**

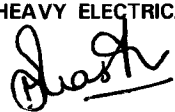

MANAGER / PURCHASE
(FOSSIL BOILERS)
Yours faithfully,

Technical Annexure (Annexure - I)		
Sl. No.	Item Specification	Bidder Confirmation
1	Electrode Holder(Fully insulated) for rated current 400 amperes at 35 % Duty Cycle .	
2	Electrode holder as per EN 60974-11:2010 .	
3	Electrode Holder Handle material - GF Polyamide.	
4	Electrode holder is suitable for electrode diameter 2.4 mm to 5.0 mm	
5	Electrode Holder Jaw - Open Type.	
6	Maximum Distance between the Handle (Lower surface) and lever (top surface) shall be less than 85 mm.	
7	Electrode holder is suitable for upto 50 square mm welding cable.	
8	Electrode holder shall permit following point. (1)The safe and rapid fitting of electrodes and release of stub ends. (2) Welding until a stub of 50 mm length with electrode clamped in any of the set positions provided. (3)The electrode to be pulled off the work piece in the event of unwanted sticking to the work piece. (4) The clamping of all electrode diameters as specified (from diameter 2.4 mm to 5.0 mm) without pressure being exerted by the operator.	
9	First Delivery Schedule -1000 numbers by 26.01.2015 Second Delivery Schedule -Balance quantities by 30.03.2015.	
10	Following confirmation is required . (1)Electrode holder Brand/Trade Name (2) Attach Product Cataloge.	
11	"Electrode holder as per EN 60974-11:2010" Manufacturer's conforming Test Certificate is required along with each supply.	

Sign and Seal of Authorized Person
(With Date)

CAUTION: THIS DRAWING IS OUR SOLE PROPERTY AND SHOULD NOT BE USED IN ANY FORM OR MANNER WITHOUT THE WRITTEN PERMISSION OF BHARAT HEAVY ELECTRICALS LIMITED, TRICHYAPALLI - 620 014.

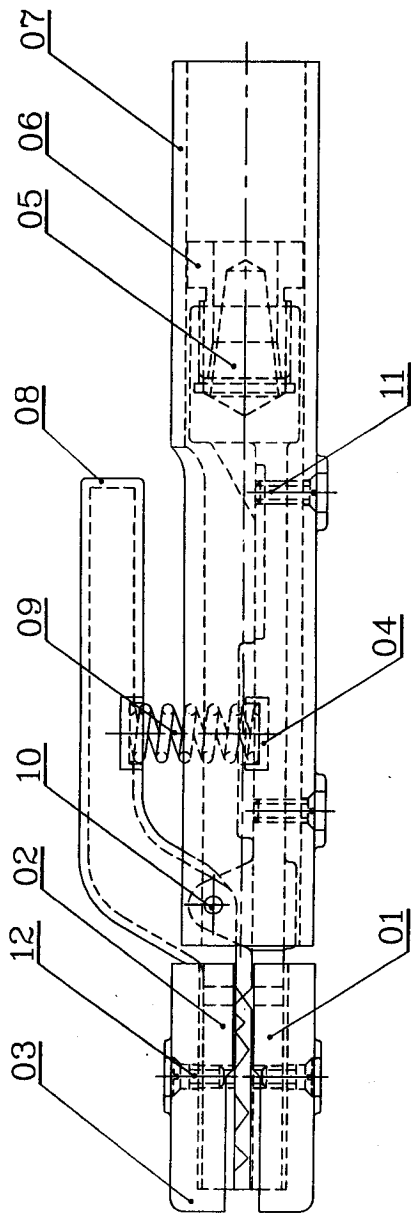
ALL DIMENSIONS ARE IN MM



No. of Pieces	DESCRIPTION	MATERIAL	STANDARD	NET WT. IN KGS.	DRAWING No.	REV.
1	HEX.NUT-M20x2	FNB	IS: 6912		4-M-10A43-28061	06
1	TAPER PLUG	FNB	IS: 6912		4-M-10A43-28060	05
2	SPRING RETAINER	BAKELITE			4-M-10A43-28059	04
2	JAW COVER	HEAT RESISTANCE UNBREAKABLE FIBRE			4-M-10A43-28064	03
1	TOP JAW	FNB	IS: 6912		3-M-10A43-12949	02
1	BOTTOM JAW	FNB	IS: 6912		3-M-10A43-12948	01
				0.575		

No. of Pieces	DESCRIPTION	MATERIAL	STANDARD	NET WT. IN KGS.	DRAWING No.	REV.
2	CSK HD.SCREW M5x12L	A8M	IS 617			
2	CSK HD.SCREW M5x10L	A8M	IS 617			
1	PIN ϕ 4x20L	45C8	IS: 7283			
1	COMP.SPRING	50 Cr 4 V2	IS 2507		4-M-10A43-28063	09
1	HANDLE INSULATION	HEAT RESISTANCE UNBREAKABLE FIBRE			4-M-10A43-28062	08
1	HOLDER COVER	HEAT RESISTANCE UNBREAKABLE FIBRE			3-M-10A43-12950	07

DESCRIPTION	DATE	SIGN.	INDEX
CHECKED R.RAMAMOORTHY			
APPROVED C.S.JAYASHEELAN			
DATE 20-09-07			

TITLE: SMAW ELECTRODE HOLDER WITH MODIFIED HANDLE FOR NARROW GAP WELDING 400 AMPS (FULLY INSULATED)

DRAWING No: 3M10A4312947

Sheet No: 1

3.2/√

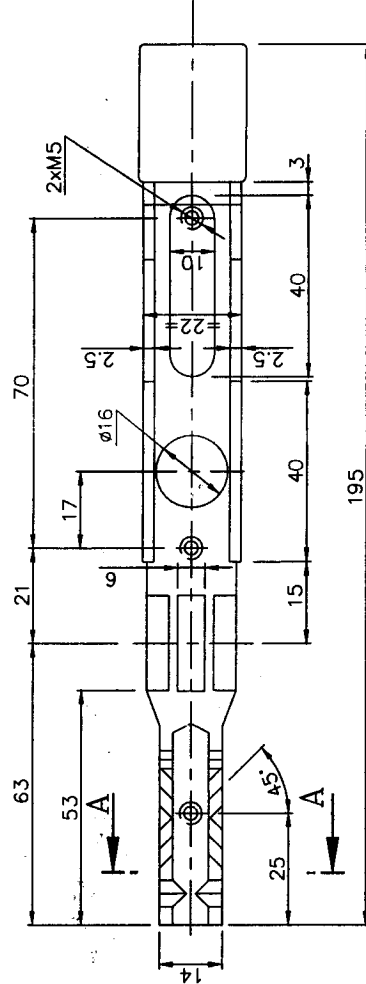
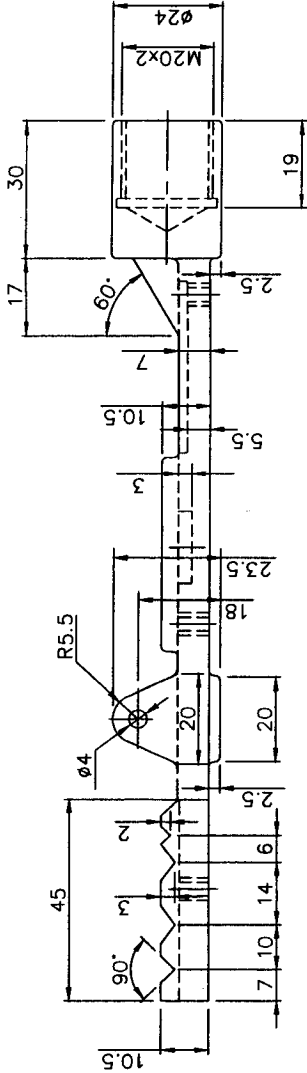
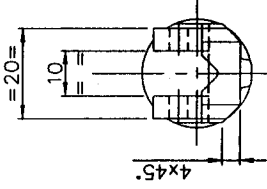

SECTION-AA

MATL. COMPOSITION : NAVAL BRASS

CU-61-64, Pb-0-2MAX.,

Sn 1.0 TO 1.5, Fe-0.10MAX.,

REST-Zn

∅24x195	FNB	IS: 6912	3-M-10A43-12947	01
DESCRIPTION	MATERIAL	STANDARD	NET.WT. IN KGS.	DRAWING No.
REFERENCE:		ALTERATIONS:	DCN REF.	DATE
SCALE	G.G.R.			
DRAWN	R.RAMAMOORTHY			
CHECKED	C.S.JAYASHEELAN			
APPROVED				
DATE	20-09-07			
MACHINE	WELDING ACCESSORIES	TYPE:	WTC	
TITLE:	BOTTOM JAW (MODIFIED)		DRAWING No.	REV.
	400 AMPS (FULLY INSULATED)		3M10A4312948	
			SHEET No.	Noof Sheets

ALL DIMENSIONS ARE IN MM

CAUTION: THIS DRAWING IS OUR SOLE PROPERTY AND SHOULD NOT BE USED IN ANY FORM FOR ANY PURPOSE WITHOUT THE WRITTEN PERMISSION OF BHARATI HEAVY ELECTRICALS LIMITED TRICHYRAIPALIT - 689 014.

3.2/√

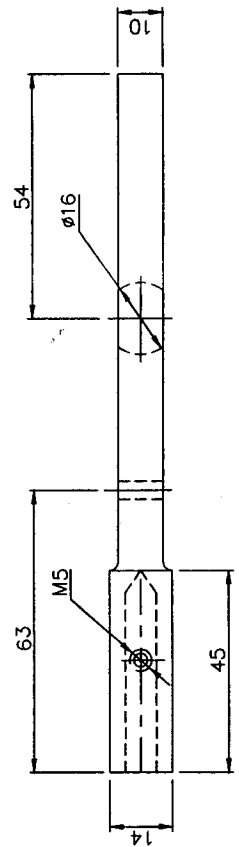
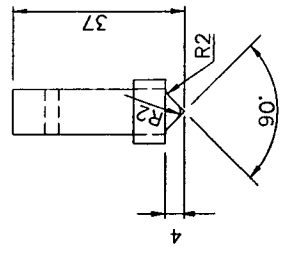
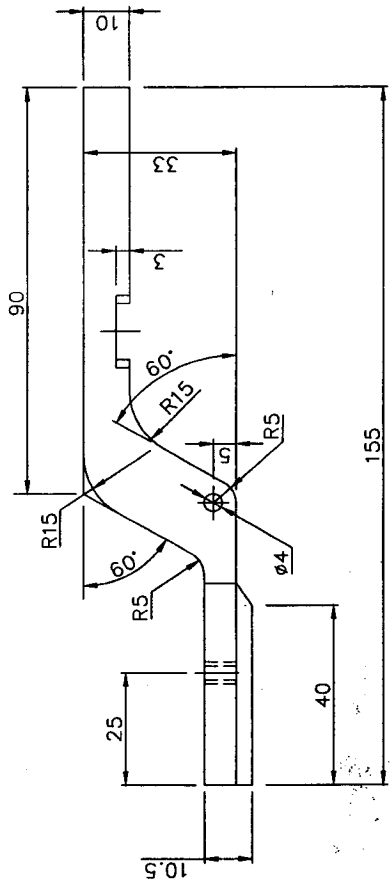

MATL. COMPOSITION : NAVAL BRASS
 CU-61-64, Pb-0-2MAX.,
 Sn 1.0 TO 1.5, Fe-0.10MAX.,
 REST-Zn

CAUTION: THIS DRAWING IS OUR SOLE PROPERTY AND SHOULD NOT BE USED IN ANY FORM FOR ANY PURPOSE WITHOUT THE WRITTEN PERMISSION OF BHARTI HEAVY ELECTRICALS LIMITED TRICHIRAPPALLI - 620 014.

ALL DIMENSIONS ARE IN MM

No. of Pieces	DESCRIPTION	FNB	IS: 6912	3-M-10A43-12947	02
		MATERIAL	STANDARD	NET.WT.IN KGS.	DRAWING No.
SCALE	REFERENCE	ALTERATIONS:			
DRAWN/TCO	G.G.R	DCN	REF	DATE	SIGN.
CHECKED	R.RAMAMOORTHY				
APPROVED	C.S.JAYASHEELAN				
DATE	20-09-07				
MACHINE: WELDING ACCESSORIES		TYPE: WTC			
TITLE:		DRAWING No:			
TOP JAW (MODIFIED)		3M110A4312949			
400 AMPS (FULLY INSULATED)		Sheet No.			
		No. of Sheets			

ALL DIMENSIONS ARE IN MM

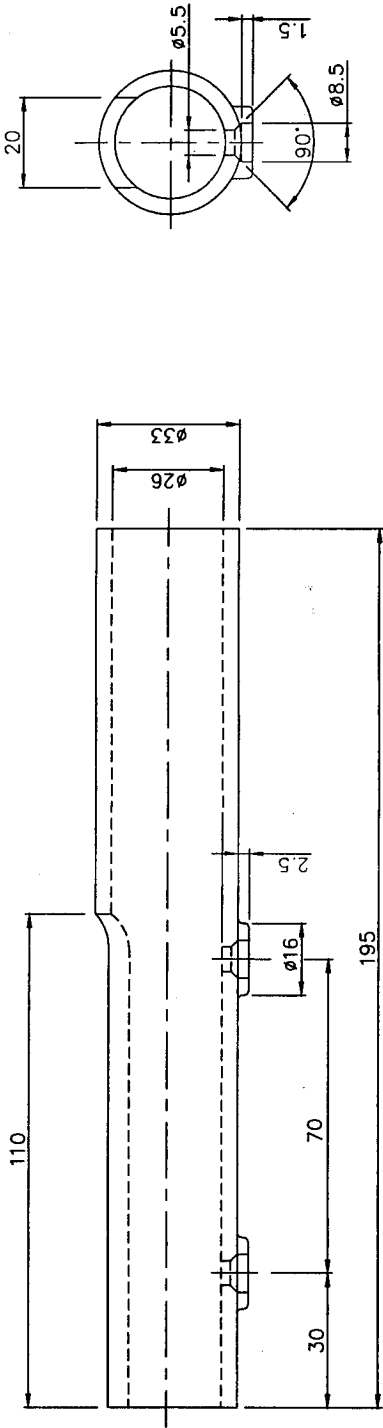

CAUTION: THIS DRAWING IS OUR SOLE PROPERTY AND SHOULD NOT BE USED IN ANY FORM FOR ANY PURPOSE WITHOUT THE WRITTEN PERMISSION OF BHARAT HEAVY ELECTRICALS LIMITED. TRICHYRAIPALLI - 689 014.

No. of Pieces	HEAT RESISTANCE UNBREAKABLE FIBRE		3-M-10A43-12947 07	
	DESCRIPTION	STANDARD	NET WT. IN KGS.	DRAWING No.
SCALE	REFERENCE:		DCN REF	DATE
	DRAWN	G.G.R.		
/	CHECKED	R. RAMAMOORTHY		
	APPROVED	C.S. JAYASHEELAN		
	DATE	20-09-07		
MACHINE: WELDING ACCESSORIES		TYPE: WTC		
TITLE:		DRAWING No:		REV.
HOLDER COVER (MODIFIED)		3M10A4312950		
400 AMPS (FULLY INSULATED)		Sheet No:		Neof Sheets

CAUTION: THIS DRAWING IS OUR SOLE PROPERTY AND SHOULD NOT BE USED IN ANY FORM FOR ANY PURPOSE WITHOUT THE WRITTEN PERMISSION OF BHARAT HEAVY ELECTRICALS LIMITED TRICHIRAPPALLI - 620 014.

ALL DIMENSIONS ARE IN MM

3.2/

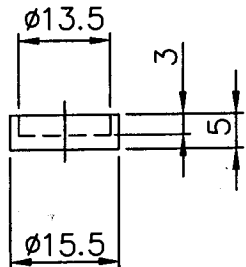



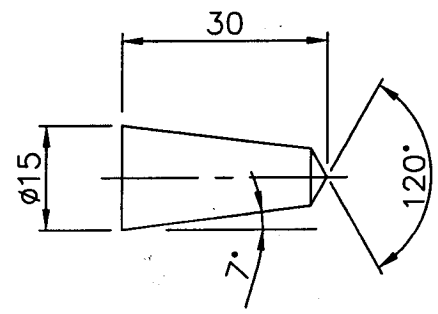

X		BAKELITE		3-M-10A43-12943		04	
3-M-10A43-12947							
No. of Pieces	DESCRIPTION	MATERIAL	STANDARD	NET.WT.IN KGS.	DRAWING No.		ITEM No.
	REFERENCE:	ALTERATIONS:		DCN REF	DATE	SIGN.	INDEX
SCALE	DRAWN/TCD	G.G.R					
/	CHECKED	R.RAMAMOORTHY					
	APPROVED	C.S.JAYASHEELAN					
	DATE	20/09/07					
MACHINE: WELDING ACCESSORIES			TYPE: WTC				
TITLE:			DRAWING No:			REV.	
			4M10A4328059				
SPRING RETAINER (MODIFIED)							
600&400 AMPS (FULLY INSULATED)			Sheet No:			No. of Sheets:	

CAUTION: THIS DRAWING IS OUR SOLE PROPERTY AND SHOULD NOT BE USED IN ANY FORM FOR ANY PURPOSE WITHOUT THE WRITTEN PERMISSION OF BHARAT HEAVY ELECTRICALS LIMITED TRICHIRAPPALLI - 620 014.

ALL DIMENSIONS ARE IN MM



MATL. COMPOSITION : NAVAL BRASS
 CU-61-64, Pb-0-2MAX.,
 Sn 1.0 TO 1.5, Fe-0.10MAX.,
 REST-Zn

		$\phi 15 \times 30$	FNB	IS: 6912	3-M-10A43-12943 3-M-10A43-12947	05
No. of Pieces	DESCRIPTION	MATERIAL	STANDARD	NET.WT.IN KGS.	DRAWING No.	ITEM No.
 	REFERENCE:	ALTERATIONS:		DCN REF	DATE	SIGN.
SCALE	DRAWN/TCD	G.G.R				
/	CHECKED	R.RAMAMOORTHY				
	APPROVED	C.S.JAYASHEELAN				
	DATE	20-09-07				
			MACHINE: WELDING ACCESSORIES		TYPE: WTC	
TITLE:			DRAWING No:		REV.	
TAPER PLUG (MODIFIED)			4M10A4328060			
600&400 AMPS (FULLY INSULATED)			Sheet No:		No. of Sheets:	

CAUTION: THIS DRAWING IS OUR SOLE PROPERTY AND SHOULD NOT BE USED IN ANY FORM FOR ANY PURPOSE WITHOUT THE WRITTEN PERMISSION OF BHARAT HEAVY ELECTRICALS LIMITED TRICHIRAPPALLI - 620 014.

ALL DIMENSIONS ARE IN MM

3.2/

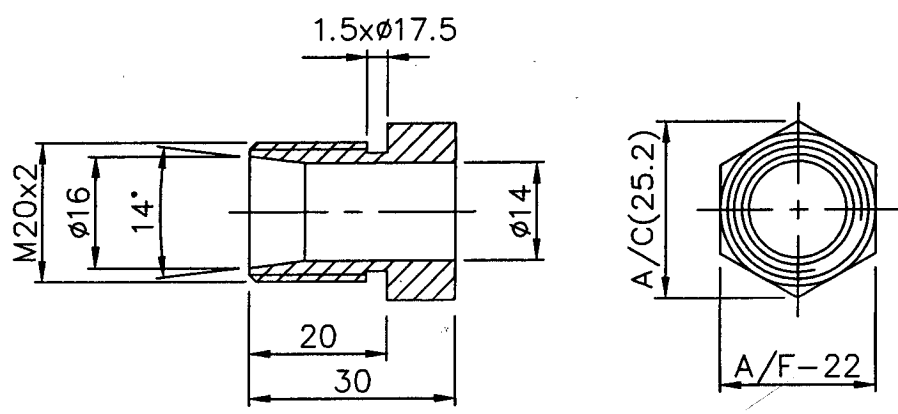

MATL. COMPOSITION : NAVAL BRASS

CU-61-64, Pb-0-2MAX.,
 Sn 1.0 TO 1.5, Fe-0.10MAX.,
 REST-Zn

No. of Pieces		DESCRIPTION		MATERIAL	STANDARD	NET.WT.IN KGS.	DRAWING No.		ITEM No.
/		G.G.R		FNB	IS: 6912		3-M-10A43-12943 3-M-10A43-12947		06
REFERENCE:				ALTERATIONS:		DCN REF	DATE	SIGN.	INDEX
SCALE		DRAWN		G.G.R					
/		CHECKED		R.RAMAMOORTHY					
		APPROVED		C.S.JAYASHEELAN					
		DATE		20-09-07					
MACHINE: WELDING ACCESSORIES				TYPE: WTC					
TITLE: HEX NUT M20x2 (MODIFIED)				DRAWING No:				REV.	
600&400 AMPS (FULLY INSULATED)				4M10A4328061					
Sheet No:				No. of Sheets:					

CAUTION: THIS DRAWING IS OUR SOLE PROPERTY AND SHOULD NOT BE USED IN ANY FORM FOR ANY PURPOSE WITHOUT THE WRITTEN PERMISSION OF BHARAT HEAVY ELECTRICALS LIMITED TRICHIRAPPALLI - 620 014.

ALL DIMENSIONS ARE IN MM

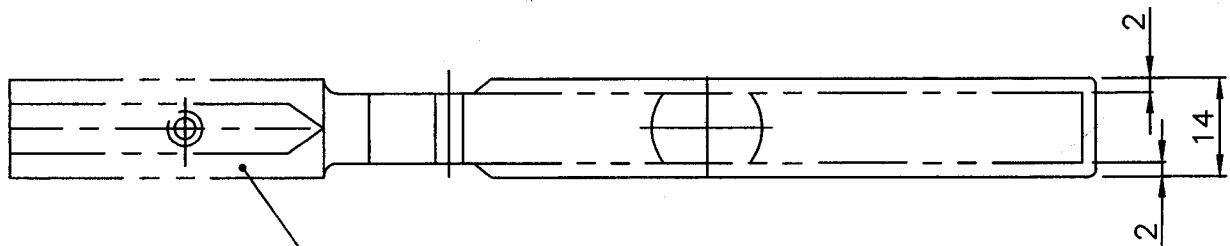
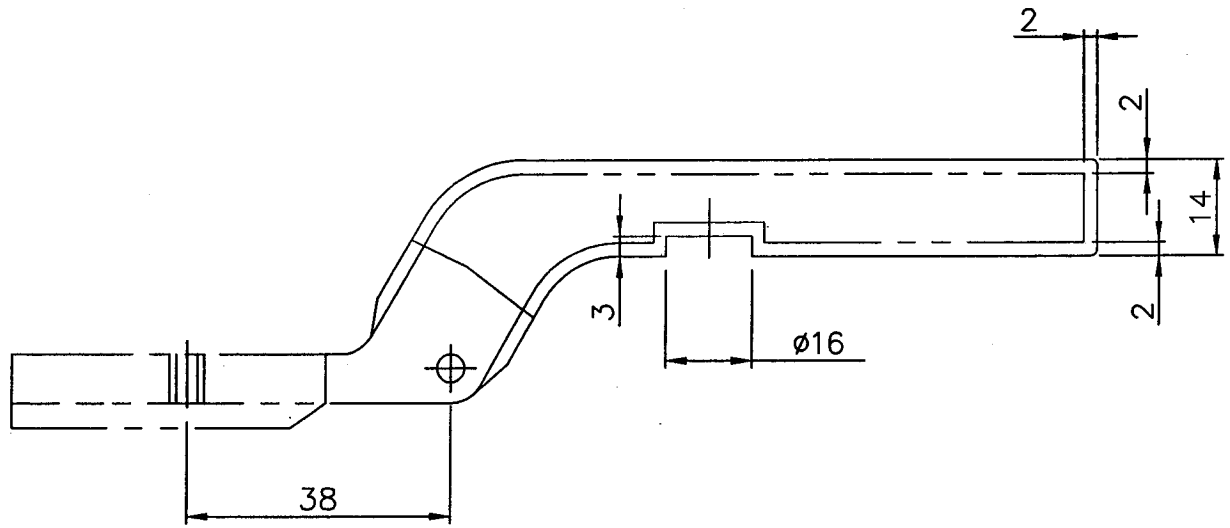

TOP JAW

X		HEAT RESISTANCE UNBREAKABLE FIBRE		3-M-10A43-12943		08	
No. of Pieces	DESCRIPTION	MATERIAL	STANDARD	NET.WT.IN KGS.	DRAWING No.	ITEM No.	
	REFERENCE:	ALTERATIONS:		DCN REF	DATE	SIGN.	INDEX
SCALE	DRAWN	G.G.R					
	CHECKED	R.RAMAMOORTHY					
/	APPROVED	C.S.JAYASHEELAN					
	DATE	20-09-07					
MACHINE: WELDING ACCESSORIES			TYPE: WTC				
TITLE: JAW COVER (MODIFIED)			DRAWING No:			REV.	
600&400 AMPS (FULLY INSULATED)			4M10A4328062				
			Sheet No:			No. of Sheets:	

CAUTION: THIS DRAWING IS OUR SOLE PROPERTY AND SHOULD NOT BE USED IN ANY FORM FOR ANY PURPOSE WITHOUT THE WRITTEN PERMISSION OF BHARAT HEAVY ELECTRICALS LIMITED TRICHIRAPPALLI - 620 014.

ALL DIMENSIONS ARE IN MM

3.2 // 1.6 //

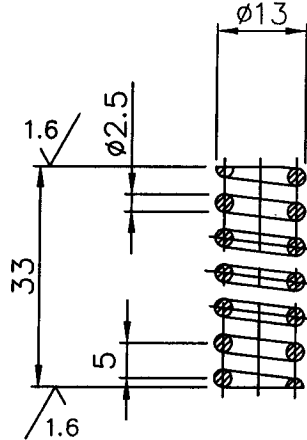

NOTE:

TOTAL No.OF COILS : 8
 EFFECTIVE COILS : 6
 ENDS : CLOSED END COILS SQUARED BY GRINDING
 HARDENED AND TEMPERED

No. of Pieces	DESCRIPTION	MATERIAL	STANDARD	NET.WT.IN KGS.	DRAWING No.	ITEM No.
	REFERENCE:	ALTERATIONS:	DCN REF	DATE	SIGN.	INDEX
SCALE	DRAWN	G.G.R				
/	CHECKED	R.RAMAMOORTHY				
	APPROVED	C.S.JAYASHEELAN				
	DATE	20-09-07				
	MACHINE: WELDING ACCESSORIES	TYPE: WTC				REV.
	TITLE: COMP. SPRING (MODIFIED) ID8xOD13x33L 600&400 AMPS (FULLY INSULATED)	DRAWING No:	4M10A4328063			
	Sheet No:		No. of Sheets:			

CAUTION: THIS DRAWING IS OUR SOLE PROPERTY AND SHOULD NOT BE USED IN ANY FORM FOR ANY PURPOSE WITHOUT THE WRITTEN PERMISSION OF BHARAT HEAVY ELECTRICALS LIMITED TRICHIRAPPALLI - 620 014.

ALL DIMENSIONS ARE IN MM

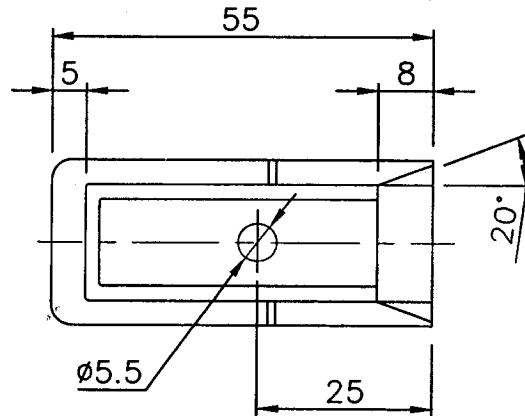
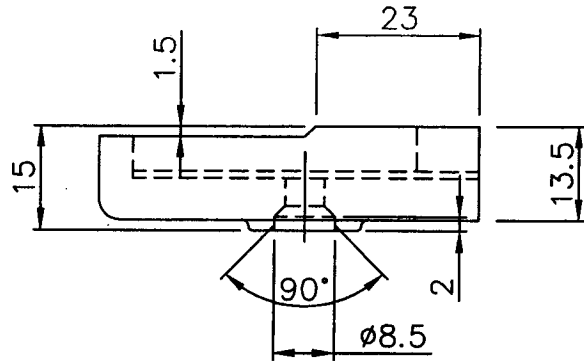
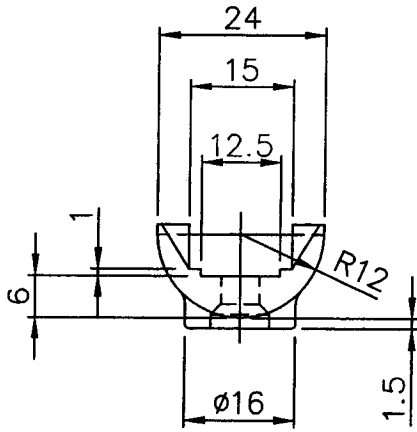

No. of Pieces		DESCRIPTION		MATERIAL	STANDARD	NET.WT.IN KGS.	DRAWING No.	ITEM No.
X		HEAT RESISTANCE UNBREAKABLE FIBRE				3-M-10A43-12947	03	
REFERENCE:		ALTERATIONS:		DCN REF	DATE	SIGN.	INDEX	
SCALE	DRAWN	G.G.R						
/	CHECKED	R.RAMAMOORTHY						
	APPROVED	C.S.JAYASHEELAN						
	DATE	20/09/07						
MACHINE: WELDING ACCESSORIES				TYPE: WTC				
TITLE: JAW COVER (MODIFIED) 400 AMPS (FULLY INSULATED)				DRAWING No:				REV.
4M10A4328064				Sheet No:				No. of Sheets:

BHARAT HEAVY ELECTRICALS LIMITED

Annexure II

(A GOVT. OF INDIA UNDERTAKING)
HIGH PRESSURE BOILER PLANT
TIRUCHIRAPPALLI-620 014

TERMS AND CONDITIONS OF THE ENQUIRY (TWO PART BID)

1. The tender will be operated on two part bid basis i.e. (i). Techno-Commercial Bid & (ii). Price Bid.

2. Techno-Commercial Bid: Containing Technical details, specifications, commercial terms and conditions like percentage of P&F charges, Freight & Insurance, ED WITH CESS, Taxes (BHEL will not provide "C" form for Non-Production Items), delivery terms, delivery schedule, validity of offer, payment terms (except price details), acceptance for LD clause, RP clause etc. as per ANNEXURE-A (submitted in your company letter head) shall be put in a cover (1) and super scribed as "Techno-Commercial Bid" for Enquiry No: Dt: Due Dt:

3. Price Bid: Containing the price details shall be put in a separate cover (2) and superscribed as "Price Bid" for Enquiry No: Dt: Due Dt: as per ANNEXURE -B (submitted in your company letter head)

4. You are requested to put the above two envelopes (Techno-Commercial Bid & Price Bid) inside a separate larger sealed envelope and this envelope shall be super scribed as "Techno-Commercial Bid and Price Bid" for Enquiry No: Dt: Due Dt:

Your Quotations should be sent to:

Senior Manager,
Purchase Department / WC, CP&SP
Materials Management / Raw Materials,
24 Building (4th Floor),
Bharat Heavy Electricals Limited,
Tiruchirappalli - 620 014.

5. Tender should not be addressed to any individual's name but only by designation.

6. Tenders should be free from CORRECTION AND ERASURES. Corrections if any must be attested; all amounts shall be indicated both in words as well as in figures. Where there is difference between amount quoted in words and figures, amount quoted in words shall only be considered.

7. Please submit point wise compliance to our specifications, terms and conditions. Otherwise it will be presumed that you are accepting BHEL's terms and conditions.

8. Offer/s received after due date and time: 02:00 pm will not be considered under any circumstances.

9. Validity of quoted rates should be maintained for 120 days from the date of Tender opening for ordering (Technical Bid). The quoted/Finalized rates shall be Firm till completion of the supplies.

10. The rates are to be quoted on F.O.R. destination basis (Inclusive of Packing, Forwarding, and Freight and Transit Insurance charges to supplier account). All the items should be supplied at our stores, BHEL / TRICHY-14 at your own cost. Offers with any other delivery conditions shall be rejected.

IMPORTANT NOTE: (i) Delivery condition like Ex-works / Ex-godown / Transportation of materials through transport carriers from your works up to the transport carrier's office at Tiruchy and taking delivery of goods by BHEL from such office of transport carriers is not acceptable to us and hence such offers shall be rejected.

11. Unloading at BHEL Site has to be done by the suppliers and BHEL will not be in a position to provide any handling/unloading facilities.

12. Payment Terms :

Payment term is 100% direct payment after 45 days from the date of receipt and acceptance of materials at BHEL Trichy Stores.

Any deviation in the above payment term will attract loading as mentioned below.

"Base rate of SBI (as applicable on the date of bid opening. Techno-commercial bid opening in case of two part bids) + 6% shall be considered for loading for the period of relaxation sought by bidders.

Offers with any other payment terms like LC / CAD / Advance payment etc. shall be rejected.

13. Liquidated Damages / Penalty:-

Liquidated damages shall be 0.5% of the total order value per week or part there of subject to a maximum of 10% of the total order value.

For staggered delivery schedule, LD shall be 0.5% of the undelivered portion per week of the delay or part thereof subject to a maximum of 10% of the total order value.

Any deviation from the above LD clause, loading will be applied to the extent to which it is not agreed by the bidder (at offered value).

14. If Guarantee / Warranty period is applicable as per tender specification, No deviation permitted and deviated offers are liable for rejection.

15. **IMPORTANT NOTE: BHEL WILL CONSIDER THE RANKING AFTER THE LOADING IS APPLIED AS REFERRED ABOVE WHEREVER DEVIATIONS ARE OBSERVED.**

16. No revision of prices will be entertained at any circumstances after tenders are opened.

17. If any sales tax is payable as extra to the quoted price it should be specifically stated in quotations along with CST & VAT Number failing which the purchaser will not be liable for payment of sales tax. Our TjN 33243560005 dt.01.01.2007 & CST no 239383 DT, 11.06.1991

18. On the due date of tender opening, only the technical bids will be opened. Technical bids will be evaluated by us and clarifications required, if any, will be called for from the bidders on technical and commercial points. The price bids of techno-commercially suitable bidders will be opened at a later date with prior intimation to respective suitable bidders.

19. Ranking L-1, L-2 etc. shall be done generally on each individual items for the techno-commercially acceptable offers on landed cost to BHEL, Trichy basis and BHEL reserves the right to place order for individual items with different vendors. At special circumstance ranking shall be done on compatible basis which will be indicated through Enquiry special instruction General Notes.

20. BHEL reserves the right to increase or decrease the tender quantity and split up the tender quantity among more than one vendor at the lowest acceptable price to BHEL and place order accordingly in any proportion at our own discretion.

21. Lowest price received against BHEL tenders need not be the technically acceptable one and in that case BHEL reserves the right not to consider the same. The purchaser shall be under no obligation to accept the lowest or any other tender and shall be entitled to accept or reject any tender in part or full without assigning any reason whatsoever.

22. BHEL reserves the right to negotiate or refloat the tender opened, if L1 price is not the lowest acceptable price to BHEL due to inter-alia other reasons.

23. **PACKING AND MARKING:** The supplier shall arrange for securely protecting and packing the stores to avoid loss or damages during transit.

24. **RISK PURCHASE:** Alternatively the purchaser at his option will be entitled to terminate the contract and to purchase elsewhere at the risk and cost of the seller either the whole of the goods or any part which the previous supplier has failed to deliver or dispatch within the time stipulated as aforesaid or if the same were not available, the best and the nearest available substitutes therefore. The new supplier shall be liable for any loss, which the purchaser may sustain by reason of such risk purchases in addition to penalty at the rate mentioned in our LD clause.

25. **PREFERENTIAL DELIVERY:** (Applicable in the case of BHEL's Enquiry specifies Preferential Delivery in the Special Instructions) It should be noted if a contract is placed on a higher tendered as a result of this invitation to tender in preference to the lowest acceptable offer in consideration of the earlier delivery, the seller will be liable to pay to the purchaser the difference between the contract rate and that of the lowest acceptable tender on the basis of final price F.O.R destination, including all elements of freights, Sales tax, duties and other incidents, incidental in case of failure to complete supplies in terms of such contract within the date of delivery specified in the tender and incorporated in the contract, such difference amount in addition to penalty at the rate mentioned in our LD clause.

26. **CENVAT CREDIT:** If any Excise Duty is payable, the Chapter Head / Sub-head reference and the rate of the duty should be quoted. If the Tenderer is availing CENVAT credit for this input material, the effect of Performa credit should be passed on to the purchaser. Tenderer under "CENVAT" shall be preferred.

27. Any other conditions which might have been quoted by the seller and are in contravention to the terms prescribed in the order and which have not been specifically accepted by purchaser in written will not be applicable to the contract.

28. **IF ANY NEW VENDORS (MANUFACTURER ONLY) WILLING TO PARTICIPATE TO THIS ENQUIRY SHOULD FURNISH**

THE FOLLOWING DOCUMENTARY PROOF / INFORMATION ALONG WITH OFFER, OTHERWISE YOUR OFFER WILL NOT BE CONSIDERED FOR EVALUATION.

- a) Certificate of Registration (copy of Certificate to be submitted).
- b) Banker's Information (copy of Bank Pass Book first Page to be submitted).
- c) MSME Vendor Certificate (if applicable).
- d) Address of your organization (Complete Postal Address with PIN Code).
- e) Contact Person/s, Phone No., Mobile No., FAX No., E-mail ID.
- f) Statutory documents – VAT/TIN/EXCISE REGISTRATION/SERVICE TAX REGISTRATION/CST REGN etc. (copy to be furnished)
- g) NSIC/SSI Certificate (if applicable)
- h) ISO Certificate (if applicable)
- i) Experience certificate as proof of supply of similar item to any Govt. agencies/PSU/Organisations. (copy of POs to be furnished)
- j) Balance Sheet for last three financial years along with Audit Report / IT Return (if applicable)
- k) Agency Agreement with manufacturer (if applicable).
- l) Partnership Deed (if applicable)

29. The bidder may also be an MSME vendor registered as per MSME act. The guidelines issued by government from time to time for engaging MSME vendor, will be applicable MSME SUPPLIERS CAN AVAIL THE INTENDED BENEFITS SHOULD SUBMIT THE FOLLOWING ALONG WITH OFFER

- i) Attested copies of either EM II (Entrepreneur Memorandum Part II) certificate having deemed validity (Two years from the date of issue of acknowledgement in EM II)
(or)
- ii) Valid NSIC certificate or EM II certificate along with CA certificate (Format enclosed as per Annexure -V) applicable for the year, certifying quantum of investment in plant machinery within the permissible limit as per the act for relevant status (Micro or Small) where the deemed validity of EM II is over.
- iii) Date to be reckoned for determining the deemed validity will be the last date of technical bid submission. Non submission of such documents will lead to consideration of their bids at par with other bidders and MSME status of such suppliers shall be shifted to Non MSME supplier till the supplier submits these documents.

30. For verification of data submitted towards evaluation of bidder's capability, BHEL may decide to visit the bidder(s) works. Any fact found deviating from submitted data shall make the bidder liable to be disqualified.

31. In the event of more than one vendor becoming L1 for any of the item / items, the enquiry quantity for those item / items will be shared equally among all the L1 vendors.

32. The correspondence between the bidder and BHEL through email is considered as valid document legally though not signed. It is treated as valid confirmations made on behalf of the respective company and comes under the legal ambit of the business transaction and hence binding on both the parties.

33. Equipment may be inspected and proved at vendor's works prior to dispatch, if applicable as per tender condition. However final inspection and acceptance of equipment will be at BHEL, Trichy.

34. Erection / commissioning charges, if applicable as per tender condition will be clearly mentioned in the offer or else confirmation that Erection / commissioning shall be done at free of cost is available in the offer.

35. Price shall be quoted item wise.

36. Any warranty replacement during warranty period shall be supplied free of charge on FOR BHEL, Trichy basis

37. The vendor shall provide necessary drawings, Test Certificates and Operating Maintenance Manuals etc., as called for in the Technical Specification, in the required number of copies at no extra cost.

38. Compliance to our Pre Qualification Criteria & Technical Specification is essential for consideration of your offer.

39. For the vendor willing to participate in tender opening, the representative should have valid Company ID Proof / Authorisation Letter, otherwise the representative will not be allowed to participate in tender opening.

40. If the due date of tender opening happens to be a holiday, those tenders will be opened on next working day.

41. For any clarifications, you can contact sr Chandran@bheltry.co.in or akumar@bheltry.co.in or shrivastava@bheltry.co.in

ANNEXURE -A

ENQ SL NO	BHEL SPECIFICATIONS	YOUR SPECIFICATION	Unit	Quantity	WHETHER QUOTED/ NOT QUOTED

KINDLY SPECIFY ALL ENQ SL NOS AS PER BHEL ENQUIRY. (SUBMITTED IN COVER NO: 1)

COMMERCIAL TERMS CONFIRMATION REQUIRED FROM THE SUPPLIERS (SUBMITTED IN COVER NO: 1)

SL NO	DESCRIPTION	BHEL REQUIREMENTS	SUPPLIER CONFIRMATION
1	VALIDITY	120 Days from Date of tender opening	
2	PRICE QUOTED	FOR-DESTINATION BHEL STORES TRICHY -620014	
3	EXCISE DUTY WITH CESS (Whether inclusive (or) extra) Clearly mention the percentage (or) amount	SUPPLIER TO QUOTE	
4	VAT % Clearly mention the percentage	SUPPLIER TO QUOTE	
5	CST % against form 'C' Clearly mention the percentage	SUPPLIER TO QUOTE	
6	DEIVERY SCHEDULE	AS PER TENDER SCHEDULE	
7	PAYMENT TERMS	As per Clause 12 of Terms and Conditions of the Enquiry (Two Part Bid)	
8	LIQUIDATED DAMAGES CLAUSE	As per Clause 13 of Terms and Conditions of the Enquiry (Two Part Bid)	
9	RISK PURCHASE CLAUSE	As per Clause 24 of Terms and Conditions of the Enquiry (Two Part Bid)	
10	GUARANTEE / WARRANTY	AS PER TENDER CONDITION	
11	ERECTION/ COMMISSIONING	AS PER TENDER CONDITION	
12	CONTACT PERSON DETAILS	NAME:	
		MOBILE NO:	
		LAND LINE NO:	
		EMAIL :	
		FAX:	

NOTE:-

- It is confirmed that all the terms and conditions stipulated in the Enquiry have been fully understood by us and all clarifications & details have been obtained.
- Your specific acceptance to our Payment terms, LD & Risk Purchase Clause are essential for consideration of your offer.
- No row shall be left blank. Please indicate NA, in case the Item is "not applicable"

Full postal Address:

Signature & Office Seal of the vendor

ANNEXURE -B

ENQ SL NO	BHEL SPECIFICATIONS	YOUR SPECIFICATION	Unit	Quantity	Rate in Rs.	Value in Rs.

PRICE BID FORMAT OF ALL QUOTED ITEMS, IF ANY ITEM YOUR ARE NOT QUOTED SIMPLY YOU SHOULD MENTION AS "NOT QUOTED" AGAINST THAT ENQ SL NO. (SUBMITTED IN SEPARATE COVER NO: 2)

Annexure-IV

Certificate by Chartered Accountant on letter head

This is to Certify that M/S
(hereinafter referred to as 'company') having its registered office at
..... is registered under MSMED Act 2006, (Entrepreneur
Memorandum No (Part-II) dtd:.....
Category: (Micro/Small)). (Copy enclosed).

Further verified from the Books of Accounts that the Investment of the company as on
date..... as per MSMED Act 2006 is as follows:

1. For Manufacturing Enterprises: Investment in plant and machinery (i.e. original cost
excluding land and building and the items specified by the Ministry of Small Scale Industries vide its
notification No.S.O.1722(E) dated October 5, 2006 :
Rs.....Lacs
2. For Service Enterprises: Investment in equipment (original cost excluding land and building and
furniture, fittings and other items not directly related to the service rendered or as may be notified under the MSMED
Act, 2006:
Rs.....Lacs

The above investment of Rs.....Lacs is within permissible limit of
Rs.....Lacs forMicro / Small (Strike off which is not applicable)
Category under MSMED Act 2006.

Date:

(Signature)

Name -

Membership number -

Seal of Chartered Accountant

Annexure-VI

CHECK LIST TO BE SUBMITTED ALONG WITH OFFER

SL NO	Documents submitted	Vendor's Confirmation Yes/No
01.	Offer Submitted in 2 part bid system	
02.	Annexure-A	
03.	Annexure-B	
04.	In case of new vendor whether documents attached as per Annexure-II SL.no.28	
05.	Annexure-Part-A-Pre-Qualification Criteria Submitted	
