



Bharat Heavy Electricals Limited

(High Pressure Boiler Plant)

Tiruchirappalli – 620014, TAMIL NADU, INDIA

CAPITAL EQUIPMENT / MATERIALS MANAGEMENT

An ISO 9001
Company

ENQUIRY	Phone: +91 431 257 79 38 Fax : +91 431 252 00 31 Email : tvenkat@bheltry.co.in Web : www.bhel.com
NOTICE INVITING TENDER	

TWO PART BID	Enquiry Number:	Enquiry Date:	Due date for submission of quotation:
Tender to be submitted in two Parts	2621300016	02.08.2013	02.09.2013

You are requested to quote the Enquiry number date and due date in all your correspondence. This is only a request for quotation and not an order.

Please note that under any circumstances both delayed offer and late offers will not be considered. Hence vendors are requested to ensure that the offer is reaching physically our office before 14.00 hrs on the Date of tender opening.

Item	Description	Quantity
10	EOT Cranes – 10T as per the technical specification & commercial conditions applicable (to be downloaded from web site www.bhel.com or http://tenders.gov.in)	4.00 Nos

Important points to be taken care during submission of offer

1. Delivery required 6 months from the date of purchase order.
2. EMD for this Tender will be (INR) : 2,00,000.00
3. Checklist No. **TRY/IND/06** to be filled and enclosed along with the offer failing which, the offer will not be considered for evaluation.
4. All updates, amendments, corrigenda, etc., (if any), for each tender will be posted only on the above websites from time to time, as and when required, until each tender is opened. There will be no publication of such updates, amendments, corrigenda, etc., through newspapers or any other media.

BHEL's General guidelines / instructions (refer **MM / CE / GENL / 001 - EMD**) including bank guarantee formats and list of consortium banks, commercial terms check-list can be downloaded from BHEL web site <http://www.bhel.com> or from the Government tender website <http://tenders.gov.in> (public sector units > Bharat Heavy Electricals Limited page) under Enquiry reference "**2621300016**".

Tenders should reach us before 14:00 hours on the due date
Tenders will be opened at 14:30 hours on the due date
Tenders would be opened in presence of the tenderers who have submitted their offers and who may like to be present

Yours faithfully,
For **BHARAT HEAVY ELECTRICALS LIMITED**

Sr. Manager / Capital Equipment / MM

PART A.**SECTION-I: -QUALIFING CRITERIA**

The BIDDER/VENDOR (OEM) has to compulsorily meet the following requirements to get qualified for consideration of the technical offer for the SUPPLY OF EOT CRANE

S. No.	PARTICULARS	VENDOR'S RESPONSE
1.0	Only those Bidder/vendor (OEM), who have supplied and commissioned at least ONE 10 Ton capacity EOT crane Class-3 with minimum span of 28m or higher and should have supplied frequency converter drive for similar capacity crane in the past five years should quote.	
2.0	Vendor to submit Performance certificates along with their offer from minimum two of their customers for satisfactory performance of 10T EOT Cranes of Class-3 with minimum span of 28m or higher, fitted with frequency converter drive, supplied to them and are working satisfactorily for more than one year after commissioning (as on the date of opening of Tender). Suggestive format is given in the annexure.	
3.0	The bidding FIRM should have 'in-house' or 'self-owned' facility for FABRICATION and TESTING at 125 % of the rated capacity	
4.0	The vendor should have minimum 10 years experience in design, fabrication and supply of EOT cranes. Actual experience of the vendor can be specified	
5.0	BHEL reserves the right to verify the information provided by vendor. In case the information provided by vendor is found to be false/ incorrect, the offer shall be rejected.	

PART A.**SECTION – II**

The vendors are requested to provide the following details

S. No.	PARTICULARS	VENDOR'S RESPONSE
6.0	Number of cranes supplied, installed and commissioned till date	
7.0	Number of cranes supplied, installed and commissioned till date in the QUOTED MODEL	
8.0	Number of cranes supplied, installed and commissioned till date for the following category of CUSTOMERS a) Power Utility Boiler Manufacturer b) Equipment Supplier for Process Industries [Heavy Engineering Companies] c) Research Establishments	
9.0	Details on SERVICE-AFTER-SALES Set-Up in India including the Addresses of Agents / Service Centre in India and Asia	
10.0	Any Additional Data to supplement the manufacturing capability of the BIDDER for the subject equipment.	

PART A.

PERFORMANCE CERTIFICATE

(On Customer's Letter Head)

1. Supplier of the Equipment :
2. Make & Model of the Equipment :
3. Month & Year of Commissioning :
4. Application :
5.
 - a) Crane Type:
 - b) Crane Capacity (Metric Tonnes):
 - c) Crane span :
 - d) Mechanism class :
6. Performance of the Equipment : Satisfactory /
(Strike off whichever is not applicable) Good /
Average /
Not Satisfactory
7. Any other remarks:

Date:

Signature & Seal of the Authority
Issuing the Performance Certificate

PART B.

**TECHNICAL SPECIFICATIONS FOR 10T 28.65 M SPAN ELECTRICALLY OPERATED
OVER-HEAD TRAVELLING [E O T] CRANE WITH DOUBLE GIRDER**

S.No.	PARTICULARS	BHEL SPECIFICATIONS	VENDOR's TECHNICAL OFFER (With Complete Details)
1.0.0	APPLICATION	<p>a) The subject crane is meant for the purpose of handling small to large (within the lifting capacity of the crane) components, in a heavy and large steel fabrication shop floor.</p> <p>b) The crane will be put to use for continuous duty with CT, LT and Hoist movements, which may occur simultaneously (within the operating parameters specified under Clause Nos. – 3.1.0, 3.4.0 and 3.5.0).</p> <p>c) The shop floor environment will be dust prone, humid, welding fume filled and ambient temperature going up to 45 °C.</p>	
2.0.0	SCOPE OF SUPPLY	<p>a. Design as per Tender Specifications</p> <p>b. Detailed Design and Manufacture as per <u>BHEL Specifications</u></p> <p>c. Complete Assembly and Testing before Dispatch <u>at Supplier Works</u></p> <p>d. Supply in Modules / Sub-Assemblies</p> <p>e. Complete Erection and wiring/cablings of the EOT Crane</p> <p>f. Commissioning and Performance Prove-Out of the EOT crane at BHEL, Trichy.</p>	
3.0.0	TECHNICAL SPECIFICATIONS		
3.1.0	CAPACITY	Lifting Capacity	
3.1.1	Hoist	10 Metric Tonnes	
3.2.0	SPAN	Wheel Centre to Wheel Centre Dimensions (Rail Centre to Rail Centre)	
3.2.1	Long Travel (LT) Span	28,650 mm	
3.2.2	Cross Travel (CT) Wheel Span	2,500 mm	

PART B.

**TECHNICAL SPECIFICATIONS FOR 10T 28.65 M SPAN ELECTRICALLY OPERATED
OVER-HEAD TRAVELLING [E O T] CRANE WITH DOUBLE GIRDER**

S.No.	PARTICULARS	BHEL SPECIFICATIONS	VENDOR's TECHNICAL OFFER (With Complete Details)
3.2.3	Long Travel (LT) Wheel Base	5000 mm (Minimum)	
3.2.4	Cross Travel (CT) Wheel Base	2500 mm (Minimum)	
3.3.0	Height of Lift	9,000 mm [Effective Height of Lift for the HOIST]	
3.4.0	DUTY CYCLE	Related to Drive Motor & Mechanisms	
3.4.1	Hoists	40 % CDF	
3.4.2	Long Travel	40 % CDF	
3.4.3	Cross Travel	40 % CDF	
3.5.0	SPEED	Operating / Working Speed [Maximum]	
3.5.1	Hoist	15.0 m /minute.	
3.5.2	Cross Travel (CT)	30.0 m/minute.	
3.5.3	Long Travel (LT)	60.0 m/minute.	
3.6.0	MOTOR RATINGS	Electric Motor Ratings & Frame Sizes shall be as per IS-325 and IS-1231 and also suitable for 300 starts per hour	
3.6.1	Hoist	Min.35 kW ; Frame Size – VD250 M /6 pole	
3.6.2	Cross Travel (CT)	Min. 4.9 kW ; Frame Size – VD132 M /6 pole	
3.6.3	Long Travel (LT)	Min. 2 x 12.5 kW ; Frame Size – VD180 L /6 pole	
3.6.4	Motor type	All motors shall be of 6 pole, sq. cage induction motor with 300 starts per hour rating and shall be of S4 duty cycle suitable for VVVF Drive starting, running, braking	
3.7.0	GEAR BOX	Gear Box Size (Input- Output center distance)/ No. of stages/ HP rating	
3.7.1	Hoist	HR 650 / 2 or 3 stages/ 60 HP – 1 No	

PART B.

**TECHNICAL SPECIFICATIONS FOR 10T 28.65 M SPAN ELECTRICALLY OPERATED
OVER-HEAD TRAVELLING [E O T] CRANE WITH DOUBLE GIRDER**

S.No.	PARTICULARS	BHEL SPECIFICATIONS	VENDOR's TECHNICAL OFFER (With Complete Details)
3.7.2	Cross Travel (CT)	VR 320 / 2 or 3 stages/ 9 HP – 1 No	
3.7.3	Long Travel (LT)	HR 350/ 2 or 3 stages/ 20 HP – 2 Nos	
3.7.4	All gearbox casing	Steel fabricated type and stress relieved.	
3.8.0	ACCELERATION		
3.8.1	Cross Travel (CT)	300 mm / sec.sq.	
3.8.2	Long Travel (LT)	300 mm / sec. sq.	
3.9.0	HOIST ROPE DETAILS	Construction: 6X36 or 6X37; Fibre core ; Tensile designation-1770 kg/mm ²	
3.9.1	Hoist	Dia. 18 mm ; Falls - 4	
3.10.0	CONTROL	Cabin Operation and Remote Control	
3.11.0	Type of Control	Master Control and Radio Remote Control	
3.12.0	Control Voltage	110 V AC	
3.13.0	Input Power Supply	415 Volts with $\pm 10\%$ fluctuation , 50 Hz with $\pm 3\%$ fluctuation, 3 Phase- AC	
3.14.0	Duty Class	Class – 3 [Indoor Service]	
3.15.0	Mechanism Group Classification	M 6	
3.16.0	DESIGN STANDARD	IS – 807 & 3177 / 2006	
3.17.0	Runway Rail Size		
3.17.1	Cross Travel (CT)	ISR 60 Lbs./Yard	
3.17.2	Long Travel (LT)	C R 80 (For reference only. Not supplier scope)	
3.18.0	Wheel Size		
3.18.1	Cross Travel (CT)	Dia. 250 mm – 4 Nos	
3.18.2	Long Travel (LT)	Dia. 500 mm - 4 Nos	

PART B.

**TECHNICAL SPECIFICATIONS FOR 10T 28.65 M SPAN ELECTRICALLY OPERATED
OVER-HEAD TRAVELLING [E O T] CRANE WITH DOUBLE GIRDER**

S.No.	PARTICULARS	BHEL SPECIFICATIONS	VENDOR's TECHNICAL OFFER (With Complete Details)
3.19.0	Brake Drum Size		
3.19.1	Hoist	Dia. 300 mm – 1 No	
3.19.2	Cross Travel (CT)	Dia. 160 mm - 1 No	
3.19.3	Long Travel (LT)	Dia. 200 mm – 2 Nos	
4.0.0	MAIN FEATURES	Crane Operational Features	
4.1.0	Control System	Frequency Converter type for all motions	
4.2.0	Remote Control	Radio Remote Control for all motions	
4.3.0	End Clearance	End Clearances to be fixed to suit the workshop building clearances [Refer Drawing No. M&S: PD: 08:016 – Drawing enclosed with the tender as ANNEXURE-1.]	
4.4.0	Crane Operation	Through Cabin Control and Radio Remote Control with option for control selection (using 3 way selector switch provided at end carriage)	
5.0.0	STRUCTURAL FABRICATION	Crane Structure Constructional Details	
5.1.0	Bridge / Girder	Plate formed Box type Construction for Girders, End carriages of LT and CT	
5.1.1	Cross section of Girder	<u>Girder Height (Flange inner- inner)</u> – 1480mm (Minimum) <u>Girder width (Web inner- inner)</u> – 452mm (Minimum) <u>Top flange plate thickness</u> – 12 mm (Minimum) <u>Bottom flange plate thickness</u> – 10 mm (Minimum) <u>Web plate thickness</u> – 8 mm (Minimum) <u>Width of top flange and bottom flange</u> – 490 mm (Minimum) <u>Vertical diaphragm plate thickness</u> – 6 mm (Minimum) <u>Distance between long diaphragms</u> – 1000 mm (Maximum) Vertical Diaphragms shall be made of solid plates only <u>Horizontal Stiffener to be provided</u> - An ISA 50x50x6 shall be provided	

PART B.

**TECHNICAL SPECIFICATIONS FOR 10T 28.65 M SPAN ELECTRICALLY OPERATED
OVER-HEAD TRAVELLING [E O T] CRANE WITH DOUBLE GIRDER**

S.No.	PARTICULARS	BHEL SPECIFICATIONS	VENDOR's TECHNICAL OFFER (With Complete Details)
		throughout the length of the web (for both webs) at about 1/3rd of the bridge height from the top.	
5.1.2	Camber for Bridge	The Crane Bridge shall be cambered at the top flange as well as the bottom flange. The final camber shall be between +26mm and +30mm.	
5.1.3	End Carriage	PLATE FORMED Box type Construction for the end carriages	
5.1.4	Cross section of End Carriage	<u>Height (Flange inner- inner) – 500 mm (Minimum)</u> <u>Width (Web inner- inner) – 292mm (Minimum)</u> <u>Top flange plate thickness – 12mm (Minimum)</u> <u>Bottom flange plate thickness – 10 mm (Minimum)</u> <u>Web plate thickness – 8 mm (Minimum)</u> <u>Width of Top flange and bottom flange – 350 mm (Minimum)</u> <u>Vertical diaphragm plate thickness – 6 mm (Minimum)</u> <u>Vertical Diaphragms shall be made of solid plates only</u>	
5.1.5	Jacking Pads	Jacking Pads shall be provided at the edge of the end carriage between web plates to facilitate removal of LT wheel.	
5.1.6	Rail Clearance	Minimum clearance to be maintained between rail top and the bottom flange of end carriage shall be as follows 1. For Long Travel – 100 mm 2. For Cross Travel – 50 mm	
5.2.0	Raw Material	Only steel plates tested and certified for quality by reputed inspection authorities, shall be used. Test Certificates to be produced for BHEL verification and form part of the documentation.	
5.3.0	Welded Joints	To be followed for Girder Fabrication	

PART B.

**TECHNICAL SPECIFICATIONS FOR 10T 28.65 M SPAN ELECTRICALLY OPERATED
OVER-HEAD TRAVELLING [E O T] CRANE WITH DOUBLE GIRDER**

S.No.	PARTICULARS	BHEL SPECIFICATIONS	VENDOR's TECHNICAL OFFER (With Complete Details)
5.3.1	Welding between Web plate and Top flange	Full welding shall be done on the outside between web plates and top flange. On the inside stitch welding of 50mm to be done between web plate and top flange.	
5.3.2	Welding of Vertical diaphragms	The vertical diaphragms shall be stitch welded to the top flange and both the webs. The welding shall be of equal stitch weld of 100 mm minimum..	
5.3.3	Number of Weld Joints allowed	Maximum Three joints only in girder fabrication. Welding joint at the center of the span is prohibited.	
5.3.4	Welding Electrodes	a. For all Horizontal Welding E 7018 /ER70S-6 (MIG) Electrode only should be used. b. For all Vertical Welding E 7048 /ER70S-6 (MIG) Electrode only should be used.	
5.3.5	Welded Joint Testing	All Butt Welded Joints (compression / tension and flanges / web joints) shall be subjected to 100% X-Ray Testing and X-Ray Films and its reports are to be produced for BHEL verification and form part of the documentation.	
5.4.0	Splice Joints	NO bolted SPLICE JOINT IS ALLOWED IN GIRDER FABRICATION [Girder has to be of SINGLE PIECE only to the total length of the span 28650 mm].	
5.5.0	Platform on Girders	The Platforms provided on both the Girders shall be for full length and fixed through BOLTED JOINTS only. The width of the platform shall be as follows 1. Drive Bridge – 1500 mm 2. Non-drive bridge – 1000 mm	
5.6.0	Wheel Assembly	The Wheel Assembly coming for Cross Travel (CT) & Long Travel (LT) shall be of LIVE AXLE SYSTEM with L-Type Bearings and shall be as per the BHEL Drawing No. 3-M-02R-0011993 . [Drawing is enclosed and given as ANNEXURE -2].	
5.7.0	Heat Treatment & NDT Examination	The Trolleys shall be Stress Relieved after welding and NDT examinations if required. All weldings shall be tested by NDT means [MPI, LPI & RT] after Stress Relieving operation.	

PART B.

**TECHNICAL SPECIFICATIONS FOR 10T 28.65 M SPAN ELECTRICALLY OPERATED
OVER-HEAD TRAVELLING [E O T] CRANE WITH DOUBLE GIRDER**

S.No.	PARTICULARS	BHEL SPECIFICATIONS	VENDOR's TECHNICAL OFFER (With Complete Details)
5.8.0	Machining Operation	All mechanical mating surfaces and wheel seating areas are to be machined to the required finish and protected	
5.9.0	Surface Cleaning	Both the Girders and the Trolleys are to be thoroughly cleaned after completion of all operations but prior to painting.	
5.10.0	Painting	The crane parts are to be painted as follows :	
5.10.1	At supplier site	During Stage-I inspection the inside of the girder/end carriage shall be painted with one coat of red oxide before closing. This shall be verified during inspection.	
5.10.2	At supplier site	During Stage-II inspection, the crane shall be painted with One coat of Primer with 25 microns of DFT (Dry Film Thickness) and 48 hours of compulsory curing after painting. The crane shall be dispatched with one coat of Primer only.	
5.10.3	At Erection Site	After the crane erection is complete, the crane has to be painted as follows a. Touch-up painting of Primer wherever necessary b. Two coats of Enamel Paint (Colour – Tractor Orange) each with a DFT of 25 microns and intermittent curing of minimum 16 hours.	
5.10.4	Paint & labor	All paints and labor etc. for painting at site also shall be the scope of the crane supplier.	

PART B.

**TECHNICAL SPECIFICATIONS FOR 10T 28.65 M SPAN ELECTRICALLY OPERATED
OVER-HEAD TRAVELLING [E O T] CRANE WITH DOUBLE GIRDER**

S.No.	PARTICULARS	BHEL SPECIFICATIONS	VENDOR's TECHNICAL OFFER (With Complete Details)
6.0.0	Mechanical Elements		
6.1.0	Gears	Gears in all the Stages shall be helical in design and to be of machined, lapped and hardened if necessary. Required test certificates shall be produced for BHEL verification and shall part of documentation.	
6.2.0	Gear Box Casing	Shall be of fabricated type and stress relieved by thermal heat-treatment process, prior to machining.	
6.2.1	Placing of CT Gearbox	The cross travel gearbox shall be located at the center of the CT span 2500 mm.	
6.3.0	Rope Drum	Shall be of fabricated type and stress relieved. The circumferential weld joints shall be tested by 100 % X-Ray for quality assurance.	
6.3.1	Hoist rope drum size	400 mm diameter (measured at the groove depth). It shall be located at centre of CT gauge of 2500 mm. Flanges of height 100mm minimum shall be provided at both ends of rope drum.	
6.4.0	Type of Coupling	<ul style="list-style-type: none"> a. between Motor and Gear Box- Full gear coupling b. between Gear Box and Rope Drum- Geared rope drum coupling/ spline shaft c. between Gear Box and Wheels(For LT and CT)- Half gear coupling with floating shaft (Minimum floating shaft length for Long Travel shall be 1500 mm) 	
6.5.0	Wheels	The Wheels shall be of Forged and Wheel Tread hardened to 300/350 BHN. Wheels shall be fitted with L-Type Bearings. Test certificates for wheel tread hardness shall be produced for BHEL verification and shall part of documentation.	
6.6.0	Mechanical Joints	Fit Bolts shall be as per IS 3640-1982 for all joints coming in main members & platform supports.	
6.7.0	Pulley Dimension		
6.7.1	Bottom Block Pulley , Top-return pulley size	For Hoist , the pulley size shall be 400mm (Minimum) measured at the depth of the groove	

PART B.

**TECHNICAL SPECIFICATIONS FOR 10T 28.65 M SPAN ELECTRICALLY OPERATED
OVER-HEAD TRAVELLING [E O T] CRANE WITH DOUBLE GIRDER**

S.No.	PARTICULARS	BHEL SPECIFICATIONS	VENDOR's TECHNICAL OFFER (With Complete Details)
6.7.2	Equalizer pulley size	For Hoist , the pulley size shall be 250mm (Minimum) measured at the depth of the groove. The equalizer pulley shall be fixed with ball bearings.	
6.8.0	Hook latch	Hook latch shall be provided for the hook.	
6.9.0	Gear & thruster oil	Appropriate grade oil should be supplied for all gearboxes and thruster brakes to the required quantity.	
6.10.0	Buffer	Spring loaded buffer shall be provided for Crab (CT) and end carriages (LT)	
6.11.0	Tools	The following tools of makes acceptable to BHEL shall be supplied along with each crane. Vendor to clearly specify the make of each item in the offer	
6.11.1	List of Tools	<ol style="list-style-type: none"> 1. Double end spanner –one set 2. Ring spanner -one set 3. Hammer 2lbs -one no 4. Hammer 5lbs -one no 5. Screw driver -one set 6. Screw spanner -one set 7. Cutting pliers -one set 8. Line tester -one no 9. 3T chain block - one no 10. 20 T Hydraulic Jack (Remote type) - one no 11. Grease gun (5 kg capacity) -one no 12. Socket Wrench - one set 13. Torque wrench - one set 14. Tong Tester (Fluke make) – one no. 15. DAYTON make 46 Pcs Socket and Bit Set- one set. 	

PART B.

**TECHNICAL SPECIFICATIONS FOR 10T 28.65 M SPAN ELECTRICALLY OPERATED
OVER-HEAD TRAVELLING [E O T] CRANE WITH DOUBLE GIRDER**

S.No.	PARTICULARS	BHEL SPECIFICATIONS	VENDOR's TECHNICAL OFFER (With Complete Details)
7.0.0	ELECTRICAL ELEMENTS		
7.1.0	Operational Controls	The Crane shall be provided with the following controls : a. Cabin Control [Master Control] b. Radio Remote Control [Micro processor based Two Step Push Button Type]	
7.2.0	Control Voltage	110 V AC	
7.3.0	Type of Brakes	a. Hoist - DC Brake b. Cross Travel - Thruster brake c. Long Travel - Thruster brake	
7.4.0	Protection	All Panels, Limit-Switches and Motors shall have IP 54 protection.	
7.5.0	Electric Motors	All Electric Motors shall be as per IS-325 and IS-1231 and also suitable for 300 starts per hour. Test certificates shall be produced for BHEL verification and form part of documentation.	
7.6.0	Electric Contactors	All Panels shall have only SIEMENS / L&T Contactors and shall be suitable for AC3 Duty Class. The coil voltage of all the contactors shall be 110 V. Suitable surge suppressors shall be provided for all contactors.	
7.7.0	Contactors Rating	The rating of all Contactors shall be atleast 50% higher than the respective electric motor full load current at the specified duty cycle.	
7.8.0	VVVF Drive Rating	The rating in kW of all the VVVF Drives shall be at least 25% higher than the respective motor rating at the specified duty cycle.	
7.9.0	Long Travel Motion	Dual Drive Mechanism shall be provided for LT (Long Travel) Motion.	
7.10.0	Illumination	a. Four numbers of 500 Watts Halogen Lamps shall be provided in end carriage between bridges. (Each side 2 nos) b. All Electric Panels shall be provided with suitable illumination for visibility and trouble shooting.	

PART B.

**TECHNICAL SPECIFICATIONS FOR 10T 28.65 M SPAN ELECTRICALLY OPERATED
OVER-HEAD TRAVELLING [E O T] CRANE WITH DOUBLE GIRDER**

S.No.	PARTICULARS	BHEL SPECIFICATIONS	VENDOR's TECHNICAL OFFER (With Complete Details)
7.11.0	Controller Steps	A 4-Step Controller has to be provided for a. Hoist b. Long Travel c. Cross Travel Note: Cam discs should be made of metal/bakelite only. All the master controllers shall be with dead-man control.	
7.12.0	Frequency Converter	The VVVF Drive shall be supplied with suitable DBR for all motions. The duty cycle of all the DBRs shall be 40%. Suitable input line chokes shall be provided.	
7.13.0	Portable programmable device	A portable programmable device (1 No) for uploading/downloading or modifying the parameters in the VVVF Drives shall be supplied with each crane.	
7.14.0	Under Voltage Relay	An Under voltage relay shall be provided on the output of control transformer.	
7.15.0	Anti-Collision Device	An Anti-Collision Device of infra-red type shall be provided on both sides of the crane. The operating range shall be 3.0 meters to 10.0 meters.	
7.16.0	Load Cell	a. Load Weighing System (with tolerance +/- 50 kg) with LOAD CELL (shear pin type) to be fixed / provided at the equalizer pulley. b. The display shall be of 100 mm size (JUMBO)	
7.16.1	Overload Prevention System	The crane shall be supplied with an overload prevention system that senses the load through the load cell and if the load is above the Safe Working Load, the hoist motion shall be tripped.	
7.17.0	Crab wiring	Junction box shall be avoided for wiring of Crab and in bridge end.	
7.18.0	Limit Switches	The crane shall be provided with the following limit switches. 1. Hoist Limit- Each hoist shall be provided with both rotary and counter weight limits. 2. CT Limit – Lever type limit switch 3. LT Limit – Lever type limit switch	

PART B.**TECHNICAL SPECIFICATIONS FOR 10T 28.65 M SPAN ELECTRICALLY OPERATED
OVER-HEAD TRAVELLING [E O T] CRANE WITH DOUBLE GIRDER**

S.No.	PARTICULARS	BHEL SPECIFICATIONS	VENDOR's TECHNICAL OFFER (With Complete Details)
7.19.0	Moulded Case Circuit Breaker	MCCBs shall be provided for Protective panel, Hoist, Long Travel and Cross travel motions.	
7.20.0	Cabin	<p>The following items shall be provided in the cabin.</p> <ol style="list-style-type: none"> 1. Operator chair, - As per drawing no.- 2. Light, 3. Fan, 4. Warning bell, 5. Fire extinguisher, 6. Remote Indication lamp and 7. Push button station – with the following buttons <ol style="list-style-type: none"> a. OFF Push Button - Mushroom Head [Plastic] Stay put- colour in RED. b. ON Push Button - Illuminated [GREEN colour 110Vac BA9 Filament Lamp] Flush type Push button[Plastic] c. BELL pushbutton – Projecting Head[Plastic] Push Button actuator [BLACK Colour] d. BRIDGE LIGHT ON/OFF switch - 2-Position Selector switch[Plastic] e. Each Push buttons and switch should have Legend Plate with Inscription of START, STOP, BELL & LIGHT ON/OFF marked clearly. 8. A rubber mat shall be provided at the floor of the cabin. 9. 2 nos of switch-pin sockets shall be provided in the cabin. 	
7.21.0	CT Cabling	Drag chain with cable system shall be used for CT motion. For Drag chain the make and specification to be submitted with offer with specific details of prevention of wear of chain due to chain sliding.	
7.22.0	Electric Cables and recommended current rating	All the cables used in the crane shall be insulated flexible copper cables as per IS:1554 (Part-I)- 1964 and the current rating shall be as per IS: 3961 (Part-II)- 1967	

PART B.

**TECHNICAL SPECIFICATIONS FOR 10T 28.65 M SPAN ELECTRICALLY OPERATED
OVER-HEAD TRAVELLING [E O T] CRANE WITH DOUBLE GIRDER**

S.No.	PARTICULARS	BHEL SPECIFICATIONS	VENDOR'S TECHNICAL OFFER (With Complete Details)
7.23.0	Compulsory Spares	<p>The following spares shall be compulsorily supplied along with each crane. Vendor to clearly specify the makes of each item in the offer</p> <ol style="list-style-type: none"> 1. LT wheel bearing – 1 no 2. CT wheel Bearing – 1 no 3. Thrusters for brakes – 2 nos 4. Warning bell – 1 No 5. 500 W Halogen lamp – 2 Nos 6. Limit switches – 1 No of each variety used in the crane 7. Master controller – 1 No 8. Hoist Brake drum – 1 No 9. Oil Seals- 1 No of each variety used in the crane 10. Cable drag chain- one set of mounting end plates and links equivalent to one metre length. 	

PART B.

**TECHNICAL SPECIFICATIONS FOR 10T 28.65 M SPAN ELECTRICALLY OPERATED
OVER-HEAD TRAVELLING [E O T] CRANE WITH DOUBLE GIRDER**

S.No.	PARTICULARS	BHEL SPECIFICATIONS	VENDOR'S TECHNICAL OFFER (With Complete Details)
7.24.0	Spares Price list for reference	Vendor to indicate the price of following spares for reference only. 1. Gearbox- a. Hoist Gearbox- 1 No b. Cross Travel Gearbox – 1 No c. Long Travel Gearbox – 1 No 2. Motors- a. Hoist Motor- 1 No b. Cross Travel Motor – 1 No c. Long Travel Motor – 1 No 3. Wheels a. Long Travel wheel – 1 Nos b. Cross Travel wheel – 1 Nos 4. Brake drums a. Hoist Brake drum – 1 No b. Aux Hoist Brake drum – 1 No	
8.0.0	SELECTION of BOI and COMPONENTS	The makes of Components or Bought-Out-Items shall be strictly as per the list given below.	
8.1.0	Hoist Hooks	HERMAN MOHTTA / HERCULES / SILPA UDYOG / SMRITI FORGINGS / KARACHIWALA	
8.2.0	Wire Rope	USHA MARTIN / FORT WILLIAM / RA WIRE ROPE	
8.3.0	Electric Motors	GEC / BHARAT BIJLEE / SIEMENS / KEC/ MARATHON	
8.4.0	Gearboxes	ELECON/ SHANTHI GEARS/ RADICON/ CROMPTON GREAVES	
8.5.0	DC Brake Unit	Only BCH make Brake unit and BCH make Brake Panel	

PART B.

**TECHNICAL SPECIFICATIONS FOR 10T 28.65 M SPAN ELECTRICALLY OPERATED
OVER-HEAD TRAVELLING [E O T] CRANE WITH DOUBLE GIRDER**

S.No.	PARTICULARS	BHEL SPECIFICATIONS	VENDOR's TECHNICAL OFFER (With Complete Details)
8.6.0	Radio Remote Control	Tele crane make(F24-10D) / Ittowa make (winner)	
8.7.0	Thruster Brake Unit	ELECTROMAG / SPEED-O-CONTROL / OMEGA	
8.8.0	Limit Switch (Gravity Type)	SIEMENS / INDUSTRIAL SYNDICATE / BCH / SKC / SOC	
8.9.0	Contactors	SIEMENS / L&T	
8.10.0	Over-Load-Relay	SIEMENS /L&T (THERMAL TYPE)	
8.11.0	Under voltage relay	SIEMENS /L&T	
8.12.0	HRC Fuses	GE / L&T /SIEMENS	
8.13.0	MCB	L&T/SIEMENS	
8.14.0	Rotary limit switch	SIEMENS / OMEGA / SOC / INDUSTRIAL SYNDICATE	
8.15.0	Switch fuse unit	L&T / SIEMENS / GEC	
8.16.0	Moulded case C.B	SIEMENS / L&T	
8.17.0	Pneumatic Time Delay	Only BCH make	
8.18.0	Cable drag chain	IGUS / CABLE SCHLEPP/ TSUBAKIMOTO/ GORTRAC	
8.19.0	Push - Buttons	SIEMENS / L&T /AIRON	
8.20.0	Connectors	ELMAX make or reputed make with IS approved and acceptable BHEL.	
8.21.0	Couplings	WMI / FENNER / ALFEX	
8.22.0	Bearings	SKF / NBC / ZKL	
8.23.0	Cables	Reputed Makes & IS Approved acceptable by BHEL.	
8.24.0	Bridge Light Fittings	PHILIPS / GE / CROMPTON	
8.25.0	Load Cell	IPA make only	
8.26.0	VVVF Drives	ALLEN BRADLEY / MITSUBISHI / YASKAWA Note: The supplied drive model shall be suitable for crane applications.	
8.27.0	Catalogues of Bought-	The vendor shall provide the Technical catalogues of the following bought-out	

PART B.

**TECHNICAL SPECIFICATIONS FOR 10T 28.65 M SPAN ELECTRICALLY OPERATED
OVER-HEAD TRAVELLING [E O T] CRANE WITH DOUBLE GIRDER**

S.No.	PARTICULARS	BHEL SPECIFICATIONS	VENDOR's TECHNICAL OFFER (With Complete Details)
	Out Items	items along with the offer. 1. Steel Wire rope 2. Crane duty electric motors 3. Gearbox 4. DC Brake 5. Thruster Brake 6. Radio Remote 7. Limit Switches 8. Load cell 9. VVVF Drive along with DBR selection chart. 10. Cable drag chain	
9.0.0	DOCUMENTS/ DETAILS for APPROVAL	The following documents and details are to be submitted for BHEL Approval, prior to taking up the manufacture of the crane.	
9.1.0	Drawings and Documents	Set I: a. Calculations for Selection of Electric Motors, Gear Reducers, Brakes, Couplings, etc. b. Calculations for Bridge Girder, Crab, End - Carriage and their connections. c. GA Drawing of the Crane. d. GA Drawing of Trolley e. GA Drawing of Individual Mechanisms. Set II: a. Drawings of Bridge, End-Carriage and their connection. b. Sub-Assembly Drawing for Wheels, Hook Blocks, Gear Boxes, Hoist rope drums and all brake Drum drawings.	

PART B.

**TECHNICAL SPECIFICATIONS FOR 10T 28.65 M SPAN ELECTRICALLY OPERATED
OVER-HEAD TRAVELLING [E O T] CRANE WITH DOUBLE GIRDER**

S.No.	PARTICULARS	BHEL SPECIFICATIONS	VENDOR'S TECHNICAL OFFER (With Complete Details)
		c. Wiring Diagram with Logic Circuits along with complete Bill of materials. d. Cable Selection based on Current Rating. e. Cable schedule indicating cable size and lengths. f. Drawing indicating the position of all the panels in the crane. Initially Set I drawings to be submitted in one lot and approval to be obtained from BHEL. Based on this, set II drawings to be submitted for approval.	
9.2.0	Technical Details	a. Total Weight of the Crane including all Electrical Equipment. b. Total Weight of Trolley including all Electrical Equipment c. Weight of each Bridge assembled and ready for erection with and without Mechanical and Electrical Equipment. d. Weight of End-carriage assembled and ready for erection. e. Total Weight of Structural, Mechanical and electrical Equipment and indicated separately also. f. Weight of Operator's Cabin together with all Equipment mounted in it.	
10.0.0	INSPECTION	The following schedule of stage inspections is to be strictly adhered to, prior to dispatch from the suppliers works.	
10.1.0	STAGE – I	a. Verification of Test Certificate for Raw Materials used for Girders, End-Carriages, Trolley, Gear Box Casings, etc. b. Verification of X-Ray Report of Butt-Joints in the Girders and Random Testing on the Welds, by physical examination. c. Box Girder setting before closing of the Bottom Flanges – for inspecting the quality of welding and presence of waviness d. Trolley Frame Fabrication before setting the Mechanisms e. End-Carriage Fabrication before closing of the Bottom Flanges The following Test certificates to be produced during Stage-I Inspection	

PART B.

**TECHNICAL SPECIFICATIONS FOR 10T 28.65 M SPAN ELECTRICALLY OPERATED
OVER-HEAD TRAVELLING [E O T] CRANE WITH DOUBLE GIRDER**

S.No.	PARTICULARS	BHEL SPECIFICATIONS	VENDOR'S TECHNICAL OFFER (With Complete Details)
		a. TC for plates used for bridge fabrication b. TC for plates used for End carriage fabrication c. TC for the steel rounds used for Gear fabrication. d. TC for plates used for Gearbox casing fabrication. e. X-Ray film and report for all the Butt-Joints in the girders.	
10.2.0	STAGE – II	a. Inspection of Bridges, End–Carriages and platform fabrication. b. Verification of Span & Diagonal Dimensions, Checking of Wheel Alignment, Mechanical Assemblies and Total Alignment. c. Free running of all the Mechanisms. d. Measurement of CAMBER in the Bridges. e. Complete assembly of the crane and free- running of all mechanisms f. Full / Rated Load Test for bridges and trolley and Deflection Test g. Deflection and Permanent Set Measurement. h. 25% OVER-LOAD Lifting Ability Check. The following Test Certificates to be produced during Stage-II Inspection. 1. TC for all Hoist Hooks 2. TC for Steel Wire ropes 3. TC for Heat treatment and final hardness for all gears. 4. TC for Wheel Hardness for LT and CT 5. TC for all thruster brakes 6. TC for all DCEM Brakes 7. TC for all motors 8. TC for all limit switches 9. TC for all VVVF Drives.	

PART B.

**TECHNICAL SPECIFICATIONS FOR 10T 28.65 M SPAN ELECTRICALLY OPERATED
OVER-HEAD TRAVELLING [E O T] CRANE WITH DOUBLE GIRDER**

S.No.	PARTICULARS	BHEL SPECIFICATIONS	VENDOR's TECHNICAL OFFER (With Complete Details)
11.0.0	CRANE ERECTION & COMMISSIONING		
11.1.0	Crane Erection & Cabling	Complete crane erection/installation, wiring/cabling of the various components at BHEL shall be the scope of the supplier	
11.2.0	Crane Commissioning	Commissioning of the Crane and Performance Prove –Out for 125% of Crane's Capacity and Smooth Functioning of the Crane (at BHEL Works) shall be the RESPONSIBILITY of the supplier.	
12.0.0	O & M MANUALS	Each Crane shall be provided with the following 1. Complete set of tools required for maintenance, 2. VFD Programming & Maintenance manual and Technical Information catalogue of VFD 3. Data Sheet containing the Program data loaded in the VFD units. 4. Manual for the Load cell calibration and trouble shooting THREE Copies of Erection, Operation & Maintenance Manual hard copy and soft copy in CD, containing the following technical details	
12.1.0	Drawings & Details	a. Crane GA Drawing. b. Crab Assembly Drawing. c. Total Crane Wiring Schematics. d. Detailed Wiring Diagrams for Sub-Systems /Panels e. VVVF Drive's Logic Circuits f. Wheel Assembly Drawings g. Bottom Block Assembly Drawing h. Gear Box Assembly Drawings i. Coupling Drawing and Details j. Specifications/Ratings of All Bought-Out Items	

PART B.**TECHNICAL SPECIFICATIONS FOR 10T 28.65 M SPAN ELECTRICALLY OPERATED
OVER-HEAD TRAVELLING [E O T] CRANE WITH DOUBLE GIRDER**

S.No.	PARTICULARS	BHEL SPECIFICATIONS	VENDOR's TECHNICAL OFFER (With Complete Details)
		k. Warranty/Guarantee Card for all Bought Out-items l. Trouble Shooting Chart for all Systems	
13.0.0	TRAINING	The Supplier shall arrange training for four BHEL persons at VVVF Drive OEM's works on programming, operation, maintenance and trouble shooting of the offered drive. The training period shall not be less than three days. All the costs incurred for the training shall be the scope of the supplier. The travelling, boarding and lodging expenses of BHEL persons will be borne by BHEL.	
14.0.0	Guarantee	Vendor shall provide a guarantee for a period of 12 months from the date of Commissioning of the equipment or 18 months from the date of dispatch, whichever is earlier	

CLEARANCE DIAGRAM FOR E.O.T. CRANE

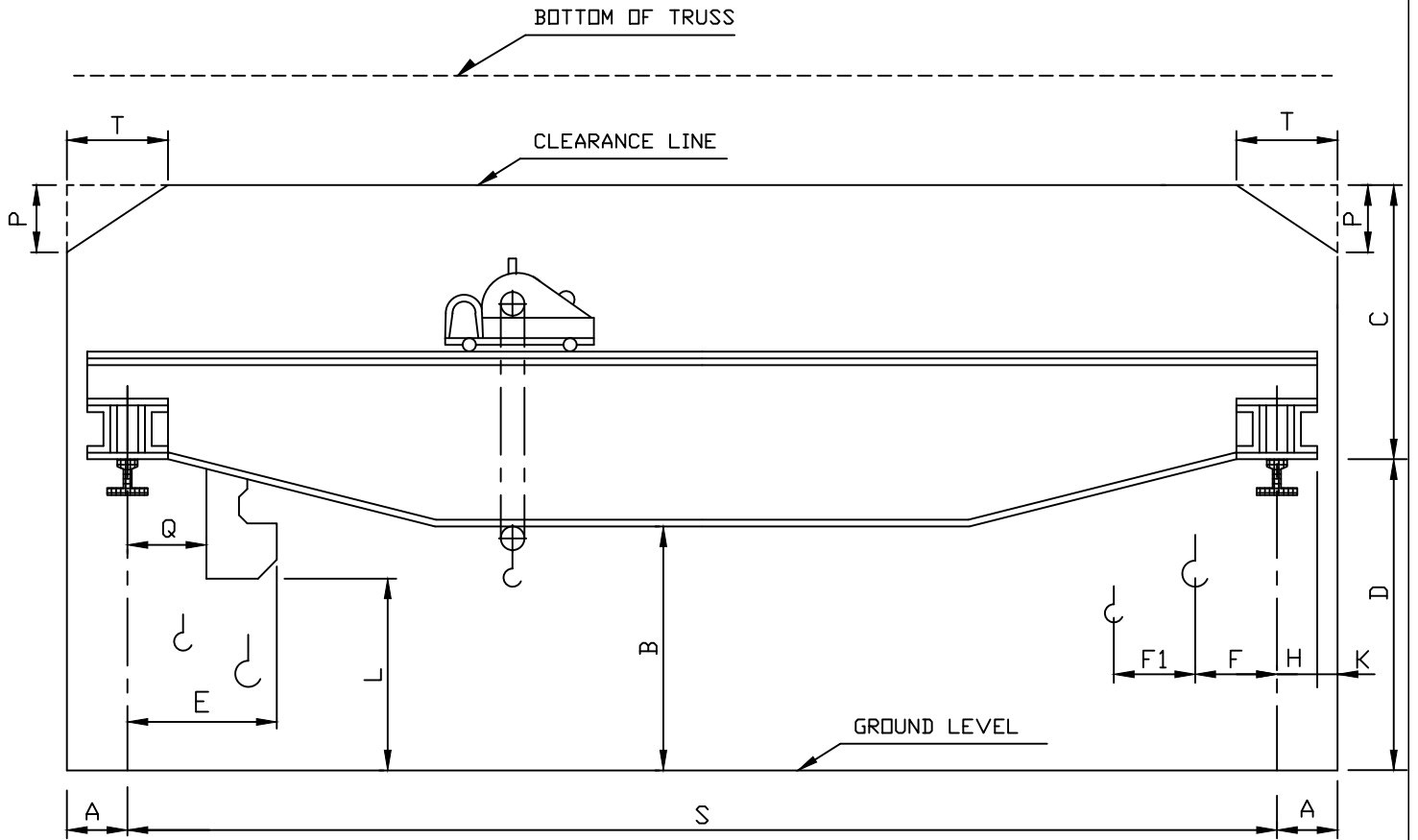

	10T×28650 9 M. LIFT				
S	28650				
D	9000				
C	3000 MAX.				
A	300				
K	100 MIN.				
T	1875				
P	1250				
B					
L					
Q					
F					
F1					
H					
E					

	DRAWN: G.G.R	DATE: 30/05/08	
TITLE:			<h2 style="margin: 0;">CLEARANCE DIAGRAM FOR E.O.T. CRANE</h2>
			<h2 style="margin: 0;">M&S: PD: 08: 016</h2>

CAUTION: THIS DRAWING IS OUR SOLE PROPERTY AND SHOULD NOT BE USED IN ANY FORM OR FOR ANY PURPOSE WITHOUT THE WRITTEN PERMISSION OF BHARAT HEAVY ELECTRICALS LIMITED, DELHI-110041 - INDIA.

ALL DIMENSIONS ARE IN MM

ANNEXURE - 2

SL. No.	O.D. (WHEEL DIA) IN MM	RAIL SIZE	A	B	D	E	F	ØG	H	ØJ	K	L	Ød	M (KEY)	N	P	Q	S	R	COUPLING No.	SKF BRG No. & BRG. SIZE	TOTAL WEIGHT IN Kg. FOR DRIVE & IDLE
16	800/850	CR-100 CR-120	190	450	80	210	150	152	140	130	212	255	32	32x18x130	687	588	20	150	80	107	22330 150x320x108	870.00 845.00
15		CR-80	168	420	80	180	110	152	125	110	212	255	32	28x16x115	687	588	20	150	80	106	22330 150x320x108	796.00 775.00
14	710/750	CR-100 CR-120	190	450	80	210	150	152	140	130	212	255	32	32x18x130	642	588	20	150	80	107	22330 150x320x108	808.00 784.00
13		CR-100 CR-120	180	420	71	210	150	132	125	110	180	224	32	28x16x115	607	517	20	130	80	106	22326 130x280x93	728.50 711.50
12	630/680	CR-80	180	400	71	180	110	132	125	110	180	224	32	28x16x115	607	517	20	130	80	106	22326 130x280x93	653.00 636.00
11		CR-80/CR-100 & CR-120	180	420	71	210	150	132	125	110	180	224	32	28x16x115	567	517	20	130	80	106	22326 130x280x93	629.00 611.50
10	500/550	80-105 Lbs/7½ CR-80	150	365	60	180	105	111	110	90	160	190	26	25x14x100	547	462	20	120	60	105	22322 110x240x80	448.00 434.50
9		CR-80 CR-100	160	375	60	180	125	111	110	90	160	190	26	22x14x100	482	462	20	120	60	105	22322 110x240x80	253.00 245.50
8	400/450	CR-80	150	360	50	180	125	91	105	80	125	160	26	22x14x90	445	395	20	100	50	104	22318 90x190x84	389.00 378.00
7		80/75/90 & 100 Lbs/7½	150	360	50	180	105	91	105	80	125	160	26	22x14x90	445	395	20	100	50	104	22318 90x190x84	301.00 294.00
6	320/370	CR-80 CR-100	150	360	50	180	125	91	105	80	125	160	26	22x14x90	395	395	20	100	50	104	22318 90x190x84	253.00 245.50
5		80 Lbs/7½ 100 Lbs/7½	145	315	40	180	105	76	85	70	112	140	22	20x12x75	375	345	16	90	50	103	22315 75x160x55	197.00 192.00
4	250/280	75 / 90 & 100 Lbs/7½ CR-80	145	315	40	180	105	76	85	70	112	140	22	20x12x75	345	345	16	90	50	103	22315 75x160x55	162.00 157.00
3		50 SO.BAR 60 Lbs/7½ 75 Lbs/7½	112.5	260	40	125	85	61	65	55	85	112	17	16x10x55	312	287	16	80	50	102	22312 60x130x46	118.50 118.00
2	200/230	50 SO.BAR 60 / 90 & 100 Lbs/7½	105	250	32	125	85	61	65	55	76	100	17	16x10x55	254	249	12	60	40	102	22212 60x110x28	66.00 63.00
1		30 Lbs/7½ 50 SO.BAR 60 Lbs/7½	95	220	32	100	67	46	55	40	71	95	17	12x8x45	239	232	12	65	40	101	22309 45x100x36	51.00 50.00

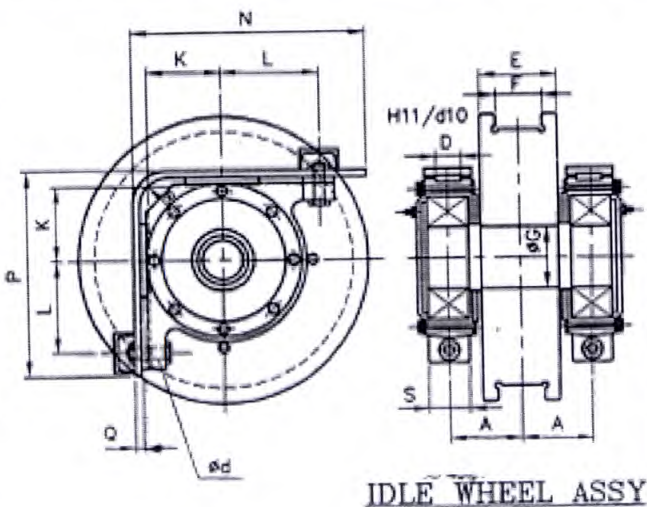
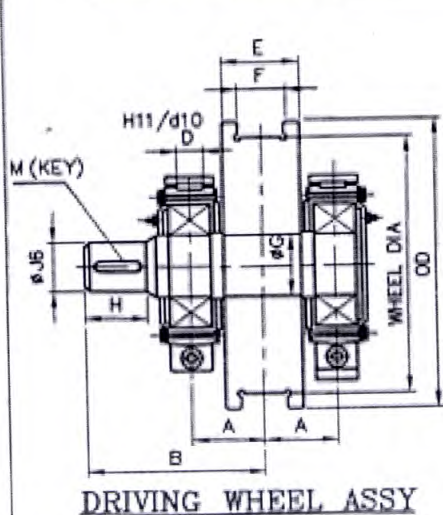

MATERIAL :- SHAFT - 45CB/15/1283.
 WHEEL - F50CB/15/1517.
 FORGED.
 TREAD PORTION WHEEL HARDNESS 500 TO 550 (BHN)

No. of Pieces	DESCRIPTION	MATERIAL	STANDARD	NET.WT.IN KGS.	DRAWING No.	ITEM No.
	REFERENCE		COMPONENT CODE: 29	EQUIPMENT CODE: 00		
SCALE	DRAWN	CHECKED	APPROVED	DATE	DCN REF	DATE
				20-10-2000		
MACHINE: CRANE WHEEL ASSY				TYPE: GENERAL		
TITLE: STANDARD CRANE WHEEL ASSY				DRAWING No. 3-M-02R-11993		
No. of Sheets				Sheet No.		