



429-002/A

BHARAT HEAVY ELECTRICALS LIMITED

(A Government of India Undertaking)
HIGH PRESSURE BOILER PLANT
PURCHASE DEPARTMENT - FOSSIL BOILERS
THIRUCHIRAPALLI - 620014
TAMILNADU (INDIA)

Page
1/4

PHONE :2577629
GRAMS : BHARATELEC
FAX NO: 2520719
E-mail: srchandran@bheltry.co.in
Web:

Enquiry No	Enquiry Date	Due Date for Quotation
2661400164 - 75	13.03.2014	05.04.2014
Please quote Enquiry No, Date and due date in all correspondences. This is only a request for quotation and not an order		

Item	Description	Unit	Quantity	Delivery Quantity	Schedule Date
10	7618A0101000 SIDE HEATING ELEMENTS AS PER PARAMETERS GIVEN IN DRG NO:3-M-18A-03-12471-REV-02.NO.(1)of ROD HEATING FURNACE.	NO	36.000	36.00	09.05.14
20	7618A0101100 FURNACE BOTTOM MIDDLE HEATING ELEMENTS WITH ALL PARAMETERS GIVEN IN/AS PER SL.NO.(2) IN DRG NO:3 M-18A-03-12471-REV-02.	NO	8.000	8.00	09.05.14
30	7618A0101200 ELECTRICAL HEATING FURNACE, BOTTOM REAR HEATING ELEMENTS WITH ALL PARAMETERS PROVIDED IN/AS PER SL.NO.(3) IN DRG NO:3-M-18A-03-12471-REV-02 . NOTE TO SUPPLY OF ALL ITEMS:-(7618A0101000,7618A0101100, 7618A0101200)	NO	12.000	12.00	09.05.14
1) PRE-DISPATCH INSPECTION IS NECESSARY. 2) DURING INSPECTION AT VENDOR WORKS, IF ANY DEVIATION IS FOUND THE SAME SHALL BE RECTIFIED BY THE SUPPLIER THEN AND THERE IMMEDIATELY. 3) MATERIALS SHALL BE DESPATCHED ONLY AFTER THE COMPLETE ACCEPTANCE BY BHEL INSPECTING ENGINEER. 4) QUALITY TEST CERTIFICATE FOR NECESSARY IS/ISO ELECTRICAL / THERMAL STANDARDS IS MUST AND TO BE PRODUCED ALONG WITH THE HEATING ELEMENTS AT THE TIME OF INSPECTION AND ONE COPY OF THE SAME MUST BE GIVEN TO INSPECTION ENGINEER.THE ORIGINAL CERTIFICATE SHALL BE SENT ALONG WITH FINISHED GOODS. 5)GUARANTY/WARRANTY CERTIFICATE FOR ONE YEAR FROM THE DATE OF MANUFACTURED, FOR RAW MATERIAL USED FOR HEATING ELEMENTS BY SUPPLIER IS REQUIRED. 6) AT THE TIME OF INSPECTION, TEST					

The offers should reach us 30 minutes before the time of opening of tenders.
The offers will be opened at 14.30 hrs on the due date of tender in the presence of tenderers who have submitted their offer and who may like to be present for the tender opening.Late and delayed offers are liable to be rejected.

Yours faithfully,
For **BHARAT HEAVY ELECTRICALS LIMITED**

MANAGER / PURCHASE
(FOSSIL BOILERS)
Yours faithfully,



BHARAT HEAVY ELECTRICALS LIMITED

(A Government of India Undertaking)
HIGH PRESSURE BOILER PLANT
PURCHASE DEPARTMENT - FOSSIL BOILERS
THIRUCHIRAPALLI - 620014
TAMILNADU (INDIA)

Page
2/4

PHONE :2577629
GRAMS : BHARATELEC
FAX NO: 2520719
E-mail: srchandran@bheltry.co.in
Web:

2661400164 / 13.03.2014

CERTIFICATE BY ORIGINAL RAW MATERIAL SUPPLIER MUST BE PRODUCED AND A COPY OF THE SAME MUST BE GIVEN TO THE BHEL INSPECTING ENGINEER.THE ORIGINAL CERTIFICATE MUST BE SENT ALONG WITH FINISHED ITEMS TO M/s BHEL,TRICHY-14.

7) ALL THE ABOVE THREE ITEMS (ENQ SL NOS. 10.TO 30) WILL BE CONSIDERED AS ONE PACKAGE AND THE TENDER WILL BE EVALUATED ON THE WHOLE PACKAGE BASIS (CLUBBING ALL THE THREE ITEMS).

NO	DESCRIPTION	QTY	UNIT	PRICE	DATE
----	-------------	-----	------	-------	------

40	7618A0100100 SUPPLY OF HEATING ELEMENTS FOR EL HEAT FURNACE (120kW)	NO	10.000	10.00	09.05.14
----	--	----	--------	-------	----------

Heating element as per drawing no. :
3 E-18C-04-13433

1) Heating element material : Kanthal brand AF grade.

2) Size of strip : 20mm width x 2mm thick

3) No of turns in each element : 29

4) Stretched length of the straight strip for each element including the terminals of Kanthal AF grade strip : 22.269 Metre.

5) Cold resistance of each element including the terminals :
0.7617 Ohms.

6) Weight of each heating elements: 6.684 kg
Test Certificate to be provided.

50	7618A0100200 SUPPLY OF HEATING ELEMENTS FOR 3 TON BAGSVIG FURNACE IN BLDG.6	NO	10.000	10.00	09.05.14
----	--	----	--------	-------	----------

Heating element as per drawing no:
2 E-18A-24-04154

Heating element material : Kanthal brand AF grade.

Size of strip : 25mm width x 2mmthick

No of turns in each element : 52

Length of straight strip : 8.445 metre

Cold resistance of each element : 0.224 ohm

Heating elements in bagsvig furnace : 27 nos

Weight of each heating elements : 3.415 kg
Test Certificate to be provided.

60	7618A0100300 KANTHAL AF GRADE HEATING ELEMENT WITH THE FOLLOWING SPECIFICATIONS.	NO	10.000	10.00	09.05.14
----	---	----	--------	-------	----------

KANTHAL heating element resistance wire - AF Grade

WIRE DIA:3.5mm

COIL OD:22mm

NO.OF TURNS IN EACH COIL:240

The offers should reach us 30 minutes before the time of opening of tenders. The offers will be opened at 14.30 hrs on the due date of tender in the presence of tenderers who have submitted their offer and who may like to be present for the tender opening.Late and delayed offers are liable to be rejected.

Yours faithfully,
For **BHARAT HEAVY ELECTRICALS LIMITED**

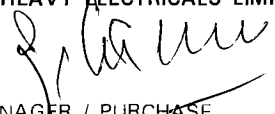
MANAGER / PURCHASE
(FOSSIL BOILERS)
Yours faithfully,



BHARAT HEAVY ELECTRICALS LIMITED

(A Government of India Undertaking)
HIGH PRESSURE BOILER PLANT
PURCHASE DEPARTMENT - FOSSIL BOILERS
THIRUCHIRAPALLI - 620014
TAMILNADU (INDIA)

Page
3/4

PHONE : 2577629
GRAMS : BHARATELEC
FAX NO: 2520719
E-mail: srchandran@bheltry.co.in
Web:

2661400164 / 13.03.2014

SHANK LENGTH : 1200mm (LENGTH OF THE COIL)
PITCH : 10mm
Total Cold Resistance for the coil : 2.08 +/-5% Ohms
TERMINAL ROD (KANTHAL 'D' GRADE)
DIA: 8mm, 400mm LENGTH
Terminal grade-Kanthal-D
KANTHAL HEATING ELEMENT DRAWING NO:
3-E-18A-10-13915
Test Certificate to be provided.

70 7618A0100400 NO 10.000 10.00 09.05.14

KANTHAL AF GRADE HEATING ELEMENT WITH THE FOLLOWING SPECIFICATIONS.
KANTHAL heating element resistance wire - AF Grade
WIRE DIA: 3.5mm
COIL OD: 22mm
NO. OF TURNS IN EACH COIL: 150
SHANK LENGTH: 750mm (LENGTH OF THE COIL)
PITCH: 10mm
Total Cold Resistance for the coil: 1.2876 +/-5% Ohms
TERMINAL ROD (KANTHAL 'D' GRADE)
DIA: 8mm, 400mm LENGTH
Terminal grade-Kanthal-D
KANTHAL HEATING ELEMENT DRAWING NO
3-M-18A-12-13021
Test Certificate to be provided.

80 7618A0100500 NO 10.000 10.00 09.05.14

SUPPLY OF HEATING ELEMENTS FOR 1 TON PRECON FURNACE
Heating element as per drawing no.
3 M 18A-01-10987
Heating element material : Kanthal brand AF grade.
Size of strip : 20 mm width x 1.5 mm thick
No of turns in each element : 23
Stretched length of straight strip for each element including the terminals of Kanthal AF Grade Strip only : 20.508 metre
Cold resistance of each element : 0.932 ohm
Weight of each heating elements : 4.662 kg
Test Certificate to be provided.

90 7618A0100700 NO 10.000 10.00 09.05.14

Backwall coils for Electrical Furnace - EL Heat
1T 60kW
Coil B as per the drawing no:
3 E 18A-01-11380
Test Certificate to be provided.

The offers should reach us 30 minutes before the time of opening of tenders.
The offers will be opened at 14.30 hrs on the due date of tender in the presence of tenderers who have submitted their offer and who may like to be present for the tender opening. Late and delayed offers are liable to be rejected.

Yours faithfully,
For **BHARAT HEAVY ELECTRICALS LIMITED**

MANAGER / PURCHASE
(FOSSIL BOILERS)
Yours faithfully,



BHARAT HEAVY ELECTRICALS LIMITED

(A Government of India Undertaking)
HIGH PRESSURE BOILER PLANT
PURCHASE DEPARTMENT - FOSSIL BOILERS
THIRUCHIRAPALLI - 620014
TAMILNADU (INDIA)

Page
4/4
PHONE :2577629
GRAMS : BHARATELEC
FAX NO: 2520719
E-mail: srchandran@bheltry.co.in
Web:

2661400164 / 13.03.2014

100	7618A0100800	NO	10.000	10.00	09.05.14
-----	--------------	----	--------	-------	----------

Side / Top coils for Precon Furnace
Coil A as per the drawing no:
3 E 18C-03-11383
Test Certificate to be provided.
NOTE: FOR ALL THE ABOVE SEVEN ITEMS
(ENQUIRY SL NOS. 40 TO 100) ORDER
WILL BE PLACED ON INDIVIDUAL ITEM L1
BASIS, NOT ON THE WHOLE PACKAGE L1
BASIS.

General Note:

1. POINT-BY-POINT CONFIRMATION TO BHEL'S SPECIFICATIONS, COMMERCIAL TERMS & CONDITIONS ARE TO BE PROVIDED BY THE VENDORS IN "ANNEXURE A&B"
2. FILL UP ANNEXURE A. PLEASE ENSURE THAT ALL TERMS & CONDITIONS SHOULD BE INDICATED IN THE UN-PRICED BID TO BE ATTACHED WITH THE TECHNO-COMMERCIAL BID POSITIVELY.
3. VALIDITY OF THE OFFER SHOULD NOT BE LESS THAN 120 DAYS.
4. ENQ SL NOS. 10 TO 30, WILL BE CONSIDERED AS ONE PACKAGE AND THE TENDER WILL BE EVALUATED ON THE WHOLE PACKAGE BASIS. FOR ENQ SL NOS. 40 TO 100, ORDER WILL BE PLACED ON INDIVIDUAL ITEM L1 BASIS, NOT ON THE WHOLE PACKAGE L1 BASIS.

LIST OF ATTACHMENTS:

1. ANNEXURE-II TERMS AND CONDITIONS OF THE ENQUIRY. (TWO PART-BID)
2. ANNEXURE-V- CA certificate format to be furnished as per MSMED act 2006, if applicable (For MSE vendors)
3. ANNEXURE-A CHECK LIST FOR COMMERCIAL TERMS CONFIRMATION-TO BE FILLED BY THE SUPPLIER.
- 4 ANNEXURE-B MODEL PRICE BID FORMAT.
5. PART -A PRE-QUALIFYING CRITERIA, PART-B TECHNICAL SPECIFICATION
6. ANNEXURE-VI CHECK LIST TO BE SUBMITTED ALONG WITH OFFER
7. ABOVE REFERRED EIGHT DRAWINGS.
8. PRE-QUALIFICATION CRITERIA

Enclosures:

"LD clause has to be confirmed without fail."

"Payment to vendors will be made only thro E-Payment mode"

The offers should reach us 30 minutes before the time of opening of tenders.
The offers will be opened at 14.30 hrs on the due date of tender in the presence of tenderers who have submitted their offer and who may like to be present for the tender opening. Late and delayed offers are liable to be rejected.

Yours faithfully,
For BHARAT HEAVY ELECTRICALS LIMITED

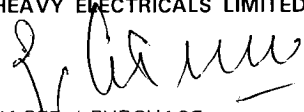
MANAGER / PURCHASE
(FOSSIL BOILERS)
Yours faithfully,

HIGH PRESSURE BOILER PLANT

TIRUCHIRAPPALLI-620 014

TERMS AND CONDITIONS OF THE ENQUIRY (TWO PART BID)

1. The tender will be operated on two part bid basis i.e. (I). *Techno-Commercial Bid* & (II). *Price Bid*.

2. **Techno-Commercial Bid:** Containing Technical details, specifications, commercial terms and conditions like percentage of P&F charges, Freight & Insurance, ED WITH CESS, Taxes (BHEL will not provide "C" form for Non-Production Items), delivery terms, delivery schedule, validity of offer, payment terms (except price details), acceptance for L.D clause, RP clause etc. as per ANNEXURE-A (submitted in your company letter head) shall be put in a cover (1) and super scribed as "Techno-Commercial Bid" for Enquiry No:Dt:Due Dt.:

3. **Price Bid:** Containing the price details shall be put in a separate cover (2) and superscribed as "Price Bid" for Enquiry No:Dt:Due Dt.: as per ANNEXURE-B (submitted in your company letter head)

4. You are requested to put the above two envelopes (Techno-Commercial Bid & Price Bid) inside a separate larger sealed envelope and this envelope shall be super scribed as "Techno-Commercial Bid and Price Bid" for Enquiry No:Dt:Due Dt.:

Your Quotations should be sent to:

*The Manager,
Purchase Department / CP&SP
Section-ELECTRICAL SPARES /266/75
Materials Management / Raw Materials,
24 Building (4th Floor),
Bharat Heavy Electricals Limited,
Tiruchirappalli - 620 014.*

5. Tender should not be addressed to any individual's name but only by designation.

6. Tenders should be free from CORRECTION AND ERASURES. Corrections if any must be attested; all amounts shall be indicated both in words as well as in figures. Where there is difference between amount quoted in words and figures, amount quoted in words shall only be considered.

7. Please submit point wise compliance to our specifications, terms and conditions. **Otherwise it will be presumed that you are accepting BHEL's terms and conditions.**

8. Offer/s received after *due date* and time: **02:00 pm** will not be considered under any circumstances.

9. **Validity of quoted rates should be maintained for 120 days from the date of Tender opening for ordering (Technical Bid). The quoted/Finalized rates shall be Firm till completion of the supplies.**

10. The rates are to be quoted on F.O.R. destpaching station basis (Inclusive of Packing, Forwarding) and separately Freight & Transit Insurance charges which are payable to supplier. ***All the items should be supplied at our stores, BHEL / TRICHY-14 at your own cost. Offers with any other delivery conditions is not acceptable.***

IMPORTANT NOTE: (I) Delivery condition like Ex-works / Ex-godown/ Transportation of materials through transport carriers from your works up to the transport carrier's office at Tiruchy and taking delivery of goods by BHEL from such office of transport carriers is not acceptable to us

11. Payment Terms (Indigenous)

Payment term is 100% direct payment after 45 days from the date of receipt and acceptance of materials.

Any deviation in the above payment term will attract loading as mentioned below.

"Base rate of SBI (as applicable on the date of bid opening. Techno-commercial bid opening in case of two part bids) + 6% shall be considered for loading for the period of relaxation sought by bidders.

Payment through Bank is not preferred. In case of Payment through Bank is opted by Supplier, BHEL prefers documents submission through bank with copy of LR and door delivery of Goods to Site/Stores with Consignee copy attached. In this case Loading will be 3% on the offered value.

Offers of indigenous Suppliers with payment terms as **LC/Advance Payment are liable for rejection.**

Payment term for supply portion(For import supplies)

BHEL Payment term is 100% payment on CAD basis after 45 days from the date of receipt of documents, specified in PO, at BHEL bank. Respective bank charges to respective account.

Any deviation in the above payment term will attract loading as mentioned below.

“Base rate of SBI (as applicable on the date of bid opening. Techno-commercial bid opening in case of two part bids) + 6% shall be considered for loading for the period of relaxation sought by bidders.

- In the case of Usance LCs the loading will be considered @ 1.5% on the offered Value.
- For LC at sight the loading will be considered @ 3.5% on the offered Value.
- Normally CAD at sight and Confirmed LCs are liable for rejection.

Payment terms for Indian agent:

Indian Agency Commission ,if any, shall be clearly specified in the offer and the same will be paid in Indian Rupees against acceptance of the materials

12. Liquidated Damages / Penalty:-

Liquidated damages shall be 0.5% of the total order value per week or part thereof subject to a maximum of 10% of the total order value.

For staggered delivery schedule, LD shall be 0.5% of the undelivered portion per week of the delay or part thereof subject to a maximum of 10% of the total order value.

Any deviation from the above LD clause, loading will be applied to the extent to which it is not agreed by the bidder (at offered value).

13. If Guarantee / Warranty period is applicable as per tender specification, No deviation permitted and deviated offers are liable for rejection.

14. IMPORTANT NOTE: BHEL WILL CONSIDER THE RANKING AFTER THE LOADING IS APPLIED AS REFERRED ABOVE WHEREVER DEVIATIONS ARE OBSERVED.

15. No revision of prices will be entertained at any circumstances after tenders are opened.

16. If any sales tax is payable as extra to the quoted price it should be specifically stated in quotations along with CST & VAT Number failing which the purchaser will not be liable for payment of sales tax. Our TIN **33243560005 dt.01.01.2007 & CST no 239383 DT, 11.06.1991**

17. On the due date of tender opening, only the technical bids will be opened. Technical bids will be evaluated by us and clarifications required, if any, will be called for from the bidders on technical and commercial points. The price bids of techno-commercially suitable bidders will be opened at a later date with prior intimation to respective suitable bidders.

18. Ranking L-1, L-2 etc. shall be done generally on each individual items for the techno-commercially acceptable offers on landed cost to BHEL, Trichy basis and BHEL reserves the right to place order for individual items with different vendors. At special circumstance ranking shall be done on compatible basis which will be indicated through Enquiry special instruction General Notes.

19. BHEL reserves the right to increase or decrease the tender quantity and split up the tender quantity among more than one vendor at the lowest acceptable price to BHEL and place order accordingly in any proportion at our own discretion.

20. Lowest price received against BHEL tenders need not be the technically acceptable one and in that case BHEL reserves the right not to consider the same. The purchaser shall be under no obligation to accept the lowest or any other tender and shall be entitled to accept or reject any tender in part or full without assigning any reason whatsoever.

21. BHEL reserves the right to negotiate or refloat the tender opened, if L1 price is not the lowest acceptable price to BHEL due to inter-alia other reasons.

22. PACKING AND MARKING: The supplier shall arrange for securely protecting and packing the stores to avoid loss or damages during transit.

23. RISK PURCHASE: Alternatively the purchaser at his option will be entitled to terminate the contract and to purchase elsewhere at the risk and cost of the seller either the whole of the goods or any part which the previous supplier has failed to deliver or dispatch within the time stipulated as aforesaid or if the same were not available, the best and the nearest available substitutes therefore. The new supplier shall be liable for any loss, which the purchaser may sustain by reason of such risk purchases in addition to penalty at the rate mentioned in our LD clause.

24. PREFERENTIAL DELIVERY:(Applicable in the case of BHEL's Enquiry specifies Preferential Delivery in the Special Instructions) It should be noted if a contract is placed on a higher tendered as a result of this invitation to tender in preference to the lowest acceptable offer in consideration of the earlier delivery, the seller will be liable to pay to the purchaser the difference between the contract rate and that of the lowest acceptable tender on the basis of final price F.O.R destination, including all elements of freights, Sales tax, duties and other incidents, incidental in case of failure to complete supplies in terms of such contract within the date of delivery specified in the tender and incorporated in the contract, such difference amount in addition to penalty at the rate mentioned in our LD clause.

25. CENVAT CREDIT: If any Excise Duty is payable, the Chapter Head / Sub -head reference and the rate of the duty should be quoted. If the Tenderer is availing CENVAT credit for this input material, the effect of Performa credit should be passed on to the purchaser. Tenderer under "CENVAT" shall be preferred.

26. Any other conditions which might have been quoted by the seller and are in contravention to the terms prescribed in the order and which have not been specifically accepted by purchaser in written will not be applicable to the contract.

27. IF ANY NEW VENDORS (MANUFACTURER ONLY) WILLING TO PARTICIPATE TO THIS ENQUIRY SHOULD FURNISH

THE FOLLOWING DOCUMENTRY PROOF / INFORMATION ALONG WITH OFFER, OTHERWISE YOUR OFFER WILL NOT BE CONSIDERED FOR EVALUATION.

- a) Certificate of Registration (copy of Certificate to be submitted).
- b) Banker's Information (copy of Bank Pass Book first Page to be submitted).
- c) MSME Vendor Certificate (if applicable).
- d) Address of your organization (Complete Postal Address with PINC ode).
- e) Contact Person/s, Phone No., Mobile No., FAX No., E-mail ID.
- f) Statutory documents – VAT/TIN/EXCISE REGISTRATION/SERVICE TAX REGISTRATION/CST REGN etc. (copy to be furnished)
- g) NSIC/SSI Certificate (if applicable)
- h) ISO Certificate (if applicable)
- i) Experience certificate as proof of supply of similar item to any Govt. agencies/PSU/ Organisation. (copy of POs to be furnished)
- j)Balance Sheet for last three financial years along with Audit Report / IT Return (if applicable)
- k)Agency Agreement with manufacturer (if applicable).
- l)Partnership Deed (if applicable)

28. The bidder may also be an MSE vendor registered as per MSE act. The guidelines issued by government from time to time for engaging MSE vendor, will be applicable.

- a. 20% of the tendered quantity is earmarked for MSE suppliers in this tender.
- b. Out of the 20% tendered quantity reserved for MSE suppliers, 4% shall be earmarked for procurement from MSE owned by SC / ST entrepreneurs.
- c. In case MSE vendor participating in the tender quotes within the price band of L1 + 15%, they will be allowed to supply the portion of the requirement subject to acceptance of L1 price by MSE vendor. In case of more than one such MSE, the supply shall be shared proportionately.
- d. MSE suppliers can avail the intended benefits only if they submit along with offer, attested copies of either EM II certificate having deemed validity (Two years from the date of issue of acknowledgement in EM II) or valid NSIC certificate or EM II certificate along with CA certificate (Format enclosed Annexure - V) applicable for the year, certifying quantum of investment in plant and machinery within the permissible limit as per the act for relevant status (Micro or small) where the deemed validity of EM II is over. Date to be reckoned for determining the deemed validity will be the last date of technical bid submission. Non submission of such documents will lead to consideration of their at par with other bidders and MSE status of such suppliers shall be shifted to Non MSE supplier till the supplier submits these documents.

29. For verification of data submitted towards evaluation of bidder's capability, BHEL may decide to visit the bidder(s) works. Any fact found deviating from submitted data shall make the bidder liable to be disqualified.

30. In the event of more than one vendor becoming L1 for any of the item / items, the enquiry quantity for those item / items will be shared equally among all the L1 vendors.

31. The correspondence between the bidder and BHEL through email is considered as valid document Legally though not signed. It is treated as valid confirmations made on behalf of the respective company and comes under the legal ambit of the business transaction and hence binding on both the parties.

32. Equipment will be inspected and proved at vendor's works prior to dispatch, if applicable as per tender condition. However final inspection and acceptance of equipment will be after installation at BHEL, Trichy.

33. Erection / commissioning charges , if applicable as per tender condition will be clearly mentioned in the

offer or else confirmation that Erection / commissioning shall be done at free of cost is available in the offer.

34. Price shall be quoted item wise.

35. Any warranty replacement during warranty period shall be supplied free of charge on FOR BHEL, Trichy basis

36. The vendor shall provide necessary drawings, Test Certificates and Operating Maintenance Manuals etc., as called for in the Technical Specification, in the required number of copies at no extra cost.

37. Part Shipment or Transshipment is not permissible. (For import supplies)

38. In case of any short shipment in the main equipment / spares, where separate rates are not available in the contract, the customs duty levied on such supplies, shall be borne by the supplier / Indian agent. (For import supplies)

39. **Indicate Nearest airport & sea port** . (For import supplies)

40. **Indicate** Country of Origin (For import supplies)

41. Vendors Meeting Our Pre-Qualification Criteria & Technical Specification Will Be Essential For Consideration Of Offer.

42. For The Vendor Willing To Participate In Tender Opening, The Representative Should Have Valid Company ID Proof & Authorization Letter From The Concerned Firm Who Has Submitted The Offer.

43. After Technical Scrutiny Of The Offers, Price Bid Of Only Technically Qualified Vendors Will Be Opened With Prior Intimation.

44. If The Due Date Of Tender Opening Happens To Be A Holiday, Those Tenders Will Be Opened On Next Working Days.

45. For any clarification you can contact to srchandran@bheltry.co.in, pgavictor@bheltry.co.in, ravic@bheltry.co.in

46. This Tender Is Hosted Both In BHEL Website And In NIC, PSU Portal And Any Corrigendum May Be Viewed in **BHEL's website <http://www.bhel.com>** (Tender Notification page)
Govt. Tender website **<http://tenders.gov.in>** (Public sector units > Bharat Heavy Electricals Limited Page)

47. Point-By-Point Confirmation To BHEL's Specifications, Commercial Terms & Conditions Are To Be Provided By The Vendors In "Annexure A&B"
Fill Up Annexure A. Please Ensure That All Terms & Conditions Should Be Indicated In The Un-priced Bid To Be Attached With The Techno-Commercial Bid Positively.

48. The Offer Should Reach Us On Or Before Due Date By 14:00 Hrs. Late Offers Will Not Be Considered.

Certificate by Chartered Accountant on letter head

This is to Certify that M/S
(hereinafter referred to as 'company') having its registered office at
..... is registered under MSMED Act 2006, (Entrepreneur
Memorandum No (Part-II) dtd:.....,
Category: (Micro/Small)). (Copy enclosed).

Further verified from the Books of Accounts that the investment of the company as on
date..... as per MSMED Act 2006 is as follows:

1. **For Manufacturing Enterprises:** Investment in plant and machinery (i.e. original cost
excluding land and building and the items specified by the Ministry of Small Scale Industries vide its
notification No.S.O.1722(E) dated October 5, 2006 :
Rs.....Lacs
2. **For Service Enterprises:** Investment in equipment (original cost excluding land and building and
furniture, fittings and other items not directly related to the service rendered or as may be notified under the MSMED
Act, 2006:
Rs.....Lacs

The above investment of Rs.....Lacs is within permissible limit of
Rs.....Lacs forMicro / Small (~~Strike off which is not applicable~~)
Category under MSMED Act 2006.

Date:

(Signature)

Name -

Membership number -

Seal of Chartered Accountant

ANNEXURE -A

ENQ SL NO	BHEL SPECIFICATIONS	YOUR SPECIFICATION	unit	Quantity	Consignment weight against each item separately	whether quoted/ not quoted
10						

KINDLY SPECIFY ALL ENQ SL NOS AS PER BHEL ENQUIRY. (SUBMITTED IN COVER NO: 1)

COMMERCIAL TERMS CONFIRMATION REQUIRED FROM THE SUPPLIERS (SUBMITTED IN COVER NO: 1)

SL NO	DESCRIPTION	BHEL REQUIREMENTS	SUPPLIER CONFIRMATION
1	VALIDITY	120 Days from Date of tender opening	
2	PRICE QUOTED	FOR / DESPATCHING STATION INCLUSIVE OF PACKING & FORWARDING CHARGES.	
3	EXCISE DUTY WITH CESS (Whether inclusive (or) extra) Clearly mention the percentage	SUPPLIER TO QUOTE	
4	VAT % Clearly mention the percentage	SUPPLIER TO QUOTE	
5	CST % against form 'C' Clearly mention the percentage	SUPPLIER TO QUOTE	
6	FREIGHT & INSURANCE CHARGES FOR DELIVERY AT BHEL / TRICHY STORES	SUPPLIER TO QUOTE IN % ONLY	
7	DEIVERY SCHEDULE FROM THE DATE OF PURCHASE ORDER / LETTER OF INTENT	SUPPLIER TO QUOTE IN N.O. OF WEEKS / MONTHS	
8	PAYMENT TERMS	As per Clause 11 of Terms and Conditions of the Enquiry (Two Part Bid)	
9	LIQUIDATED DAMAGES CLAUSE	As per Clause 12 of Terms and Conditions of the Enquiry (Two Part Bid)	
10	RISK PURCHASE CLAUSE	As per Clause 23 of Terms and Conditions of the Enquiry (Two Part Bid)	
11	GUARANTEE / WARRANTY	AS PER TENDER CONDITION	
12	ERECTION / COMMISSIONING	AS PER TENDER CONDITION	
13	Origin of dispatch	SUPPLIER TO QUOTE	
14	Nearest airport & sea port (For import supplies)	SUPPLIER TO QUOTE	
15	Country of Origin (For import supplies)	SUPPLIER TO QUOTE	
16	CONTACT PERSON DETAILS	NAME:	
		MOBILE NO:	
		LAND LINE NO:	
		EMAIL :	
		FAX:	

NOTE: a). -It is confirmed that all the terms and conditions stipulated in the Enquiry have been fully understood by us and all clarifications & details have been obtained.

b).Your specific acceptance to our Payment terms, LD & Risk Purchase Clause are essential for consideration of your offer.

c).No row shall be left blank. Please indicate NA, in case the item is "not applicable"

Full postal Address:

Signature & Office Seal of the vendor

ANNEXURE –B

ENQ SL NO	BHEL SPECIFICATIONS	YOUR SPECIFICATION	unit	quantity	Rate in Rs.	Value in Rs.
10						

PRICE BID FORMAT OF ALL QUOTED ITEMS, IF ANY ITEM YOUR ARE NOT QUOTED SIMPLY YOU SHOULD

MENTION AS “NOT QUOTED” AGAINST THAT ENQ SL NO. (SUBMITTED IN SEPARATE COVER NO: 2

Annexure-VI

CHECK LIST TO BE SUBMITTED ALONG WITH OFFER

SL NO	Documents submitted	Vendor's Confirmation Yes/No
01.	Offer Submitted in 2 part bid system	
02.	Annexure-A	
03.	Annexure-B	
04.	In case of new vendor whether documents attached as per Annexure-II SL.no.27	
05.	For MSME vendors whether documents submitted as per Annexure-II SL.no.28	
06.	Annexure- Pre-Qualification Criteria Submitted	
07.	Documents/technical catalogues /DRAWINGS, (wherever as applicable) submitted as per tender condition	
08.	point to point confirmation provided as per tender condition	

ENQ. SL NO: 10 TO 30

CAUTION: THIS DRAWING IS OUR SOLE PROPERTY AND SHOULD NOT BE USED IN ANY FORM FOR ANY PURPOSE WITHOUT THE WRITTEN PERMISSION OF BHARAT HEAVY ELECTRICALS LIMITED TRICHYRAPPALI - 620 014.

ALL DIMENSIONS ARE IN MM

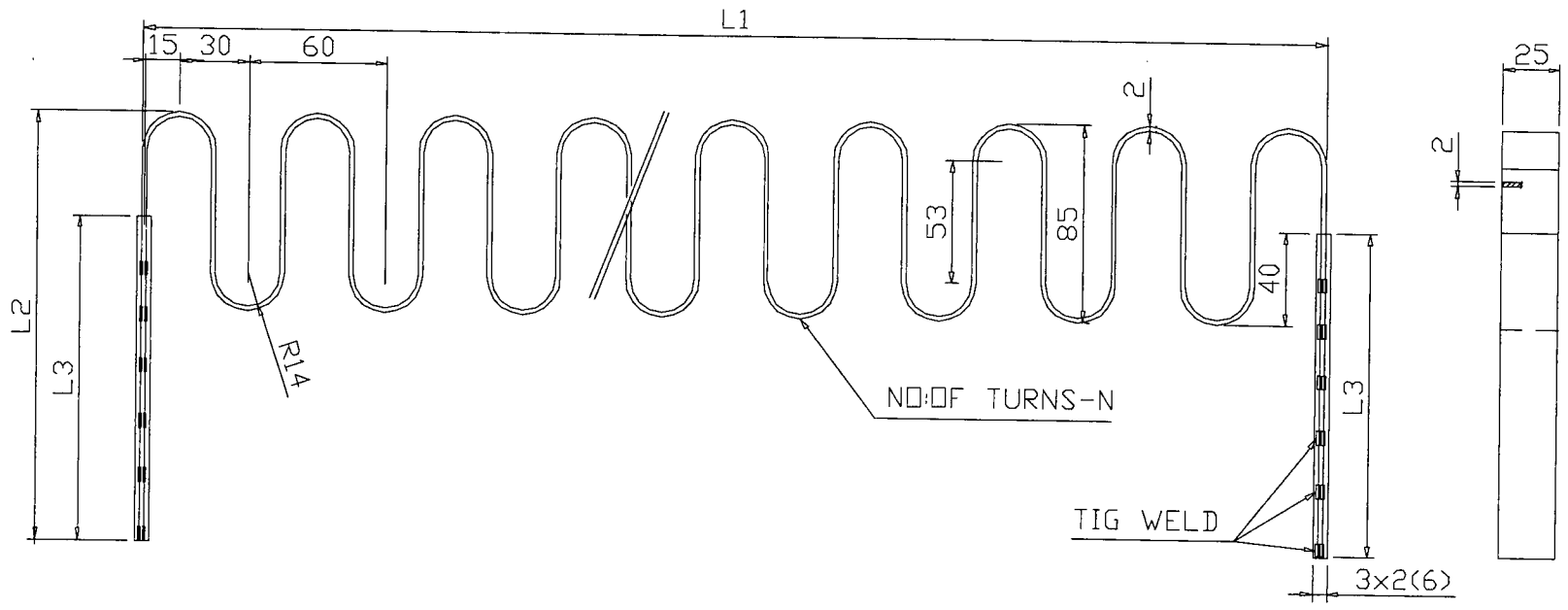

SL No	DESCRIPTION	GRADE & SIZE	STRIP LENGTH	COLD RESISTANCE	No OF TURNS	L1	L2	L2	No OF COILS ZONE	No OF COILS PHASE	FURNACE TEM. °C	CURRENT /PHASE	VOLT PER PHASE	KW/ PH/ ZONE	KW IN ZONE	NO OF ZONES	TOTAL KW	NET WT IN KGS	REMARKS
01	SIDE COIL	KANTAL	9800	0.29	46	2780	515	480	12	5-COILS	1200°C	160 AMPS	230 VOLT	37.5 KW	112.5	4	450 KW	4.73	24
02	MID COIL	AF	10200	0.30	49	2820	800	780	1	IN								4.92	2
03	REAR COIL	25x2t	9800	0.29	46	2790	670	630	2	SERIES								4.85	4

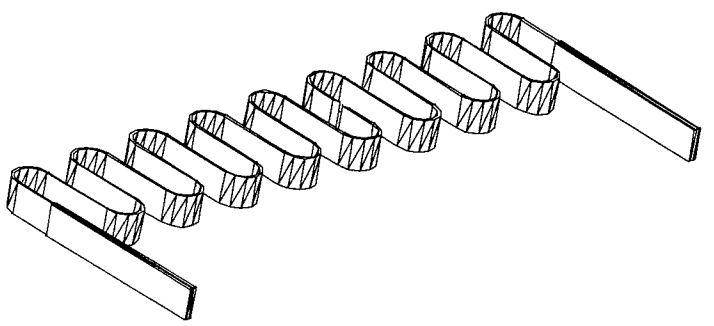

No. of Pieces		DESCRIPTION		MATERIAL		STANDARD		NET.WT.IN KGS.		DRAWING No.		ITEM No.	
REFERENCE		FURNACE No1715-1770		ALTERATIONS		DCN REF		DATE		SIGN.		INDEX	
SCALE		DRAWN/TCD		TTB		NO. OF TURNS		46 WAS 47		30.08.08		CSJ 02	
1:2		CHECKED		APPROVED		DATE		30.06.04/27.03.07					
MACHINE: ROD HEATING FURNACE						TYPE: EL HEAT-450KW							
TITLE: HEATING ELEMENT						DRAWING No: 3M18A031247102							
Sheet No:						No. of Sheets:							

ENQ. SL NO: 10 TO 30

ENQ. S1 NO: 50

1/1/1

CAUTION: THIS DRAWING IS OUR SOLE PROPERTY AND SHOULD NOT BE USED IN ANY FORM FOR ANY PURPOSE WITHOUT THE WRITTEN PERMISSION OF BHARAT HEAVY ELECTRICALS LIMITED, BIRBHADRAHALLI - 561 014.

ENQ. S1 NO: 50

ALL DIMENSIONS ARE IN MM

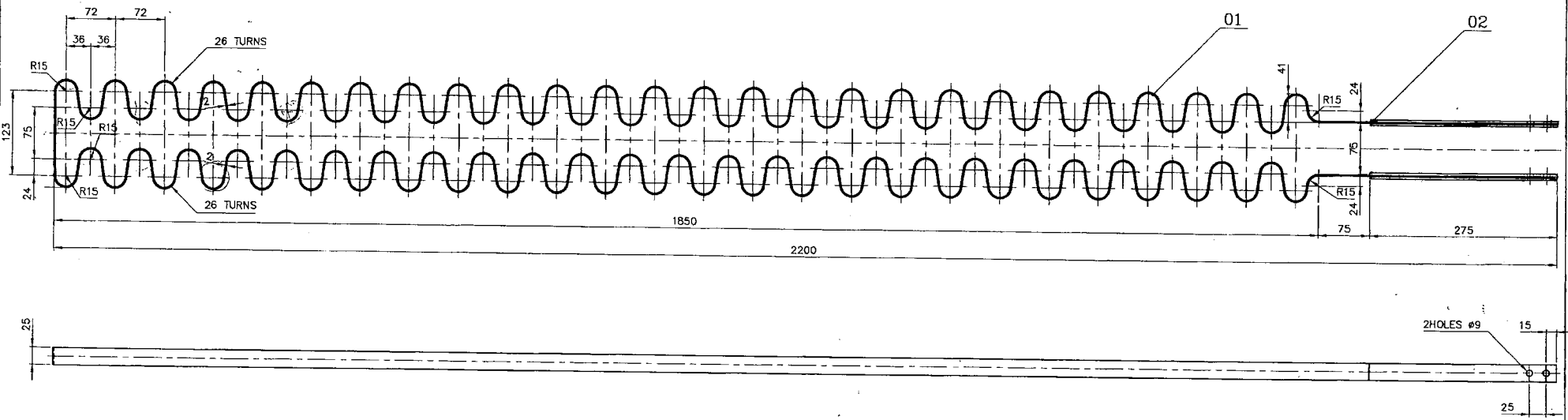

- 01 . HEATING ELEMENT MATERIAL : KANTHAL BRAND AF GRADE.
- 02 . SIZE OF STRIP : 25mm WIDTH x 2mm THICK.
- 03 . NO OF TURNS IN EACH ELEMENT : 52
- 04 . STRETCHED LENGTH OF STRAIGHT STRIP FOR EACH ELEMENT INCLUDING THE TERMINALS OF KANTHAL AF GRADE STRIP ONLY-8.445 METRE.
- 05 . COLD RESISTANCE OF EACH ELEMENT INCLUDING THE TERMINALS - 0.224 OHM.
- 06 . NO OF HEATING ELEMENTS IN BAGSVIG & TOP HAT FURNACE, 27 & 18 NOS RESPECTIVELY.
- 07 . WEIGHT OF EACH ELEMENT INCLUDING THE TERMINALS - 3.415 KG.
- 08 . CONNECTION DIAGRAM OF HEATING ELEMENTS.

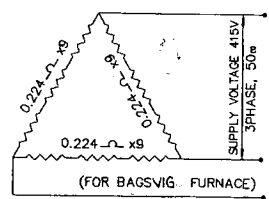
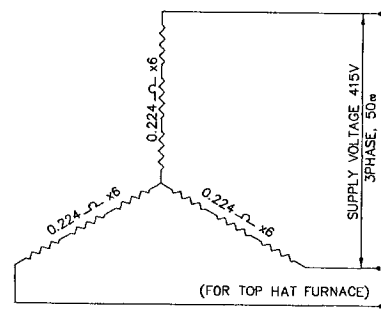

09 . MAXIMUM FURNACE TEMPERATURE - 800°C

04	PL 2x25x275	KANTHAL	D- GRADE	0.395		D2
01	PL 2x25x8445	KANTHAL	AF GRADE	3.020		01
				3.415		4-M-18A-01440
REF:	2-E-09-90-858					
SCALE	DRAWN	A RAJAO				
1:4	CHECKED	R. Ramamurthy				
	APPROVED					
	DATE	20.09.1997				
MACHINE:		ELECTRICAL FURNACE		TYPE: BHEL / 240KW & 125KW		
TITLE:		STRIP ELEMENT		DRAWING No: 24		REV.
				2-E-18A-04154		
				No of Sheets		Sheet No

ENQ. SL. NO: 60

CAUTION: THIS DRAWING IS OUR SOLE PROPERTY AND SHOULD NOT BE USED IN ANY FORM FOR ANY PURPOSE WITHOUT THE WRITTEN PERMISSION OF BHARAT HEAVY ELECTRICALS LIMITED TRICHYAPALLI - 620 014

ENQ. SL. NO: 60

ALL DIMENSIONS ARE IN MM

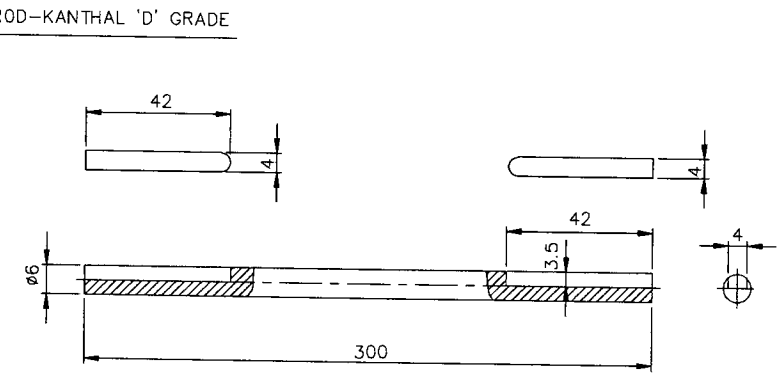
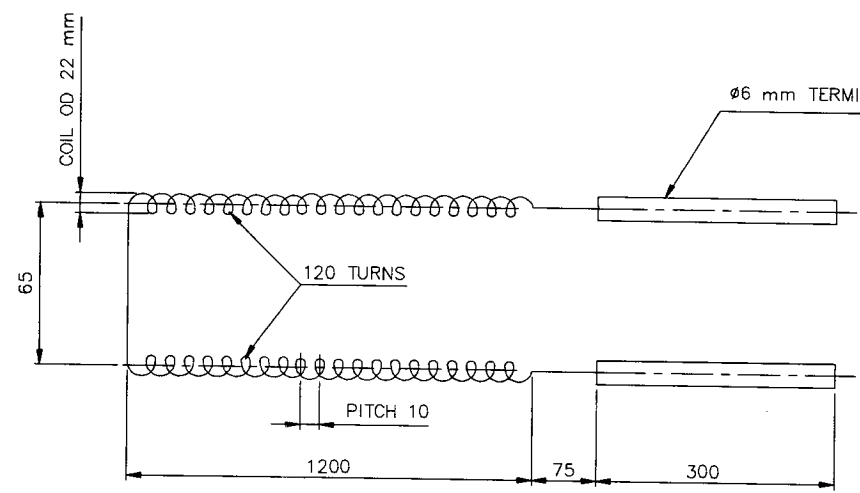

DETAILS OF TERMINAL ROD

SPECIFICATIONS: -

- 'KANTHAL' HEATING ELEMENT RESISTANCE WIRE- AF GRADE
- WIRE DIAMETER- 3.5 mm
- COIL OUTSIDE DIAMETER- 22 mm
- PITCH- 10 mm
- LENGTH OF COIL- 1200 mm
- NO.OF TURNS IN EACH COIL- 240 TURNS
- NO.OF COILS REQUIRED FOR THE FURNACE- 3 NOs,
- Ø6 mm TERMINAL ROD- KANTHAL 'D' GRADE
- TOTAL COLD RESISTANCE FOR THE COIL-2.08 ohms.

REMARK: -

THE TERMINAL ROD MUST BE WELDED TO THE COIL-
AT THE END SUITABLY.

No. of Pieces		DESCRIPTION	MATERIAL	STANDARD	NET.WT.IN KGS.	DRAWING No.	ITEM No.
REFERENCE:		LOC.No.1715-2466	COMPONENT CODE:		EQUIPMENT CODE:		
SCALE		DRAWN P. Albert rose	ALTERATIONS:		DCN REF	DATE	SIGN. INDEX
CHECKED R. Ramamoorthy		APPROVED C.S. Jayasheelan		DATE 07-07-09			
MACHINE: ELECTRICAL FURNACE				TYPE: ELHEAT IT-60 KW.			
TITLE:		BACK WALL COILS HEATING ELEMENT			DRAWING No:		REV.
					3E18A1013915		
No. of Sheets:		Sheet No:					

Caution
THIS DRAWING IS OUR SOLE PROPERTY AND SHOULD NOT BE USED IN ANY FORM FOR ANY OTHER PURPOSE WITHOUT THE WRITTEN PERMISSION OF BHARAT HEAVY ELECTRICALS LTD., TIRUCHIRAPALLI - 620 016.

ENQ. S.I. NO: 70

✓✓✓✓

39-609 A

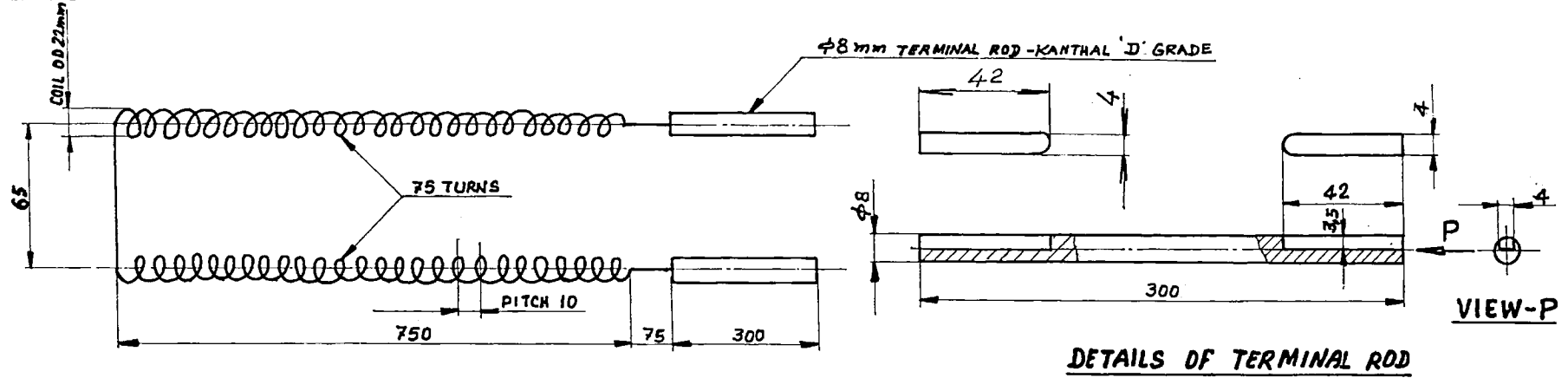

DETAILS OF TERMINAL ROD

SPECIFICATIONS:-

'KANTHAL' HEATING ELEMENT RESISTANCE WIRE - AF GRADE

- WIRE DIAMETER** - 3.5 mm
- COIL OUTSIDE DIAMETER** - 22 mm
- PITCH** - 10 mm
- LENGTH OF COIL** - 750 mm
- NO. OF TURNS IN EACH COIL** - 150
- NO. OF COILS REQUIRED FOR THE FURNACE** - 3 Nos.

8 mm TERMINAL ROD - KANTHAL 'D' GRADE

TOTAL COLD RESISTANCE FOR THE COIL - 1.301 ohm.
INCLUDING THE TERMINAL RODS.

REMARK:-

THE TERMINAL ROD MUST BE WELDED TO THE COIL AT THE END BY TIG WELDING PROCESS.
LOC. NOS: 1615-0224 & 1715-2495

ENQ. S.I. NO: 70

No. of Pcs.	DESCRIPTION	MATERIAL	STD/BPS	Net wt. (kg)	Gross wt. (kg)	DRAWING No.	Item No.
	REFERENCE :		ALTERATIONS	EC: 12	CC: 00	DATE	SIGN.
SCALE	DRAWN						
	CHECKED						
	APPROVED						
	DATE	28-03-92					
MACHINE : ELE. SINGLE CHAMBER		TYPE BHEL 48 KW.		Total wt. (kg.)			
TITLE		DRAWING No.		REV.			
BACK WALL COILS HEATING ELEMENT		3-M-18A-13021		12			
No. of Sheets:		Sheet No.					

ENR. Sl. No: 80

ALL DIMENSIONS ARE IN MM

CAUTION: THIS DRAWING IS OUR SOLE PROPERTY AND SHOULD NOT BE USED IN ANY FORM FOR ANY PURPOSE WITHOUT THE WRITTEN PERMISSION OF BHARAT HEAVY ELECTRICALS LIMITED TRICHIRAPPALLI - 620 014

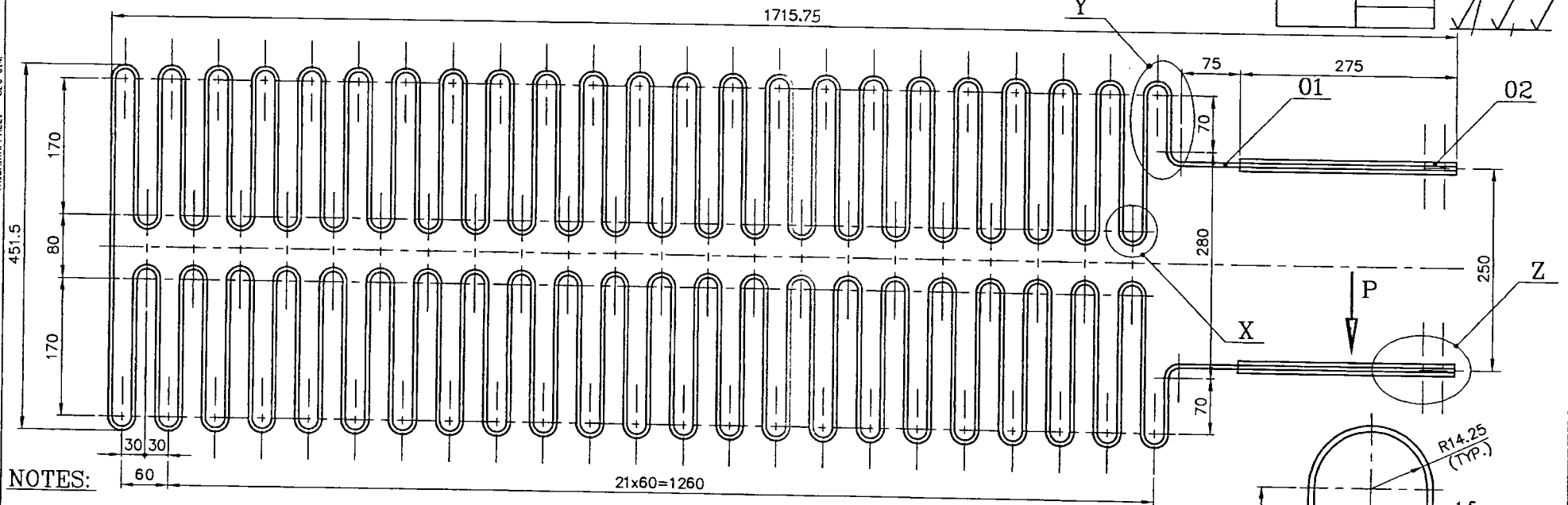

NOTES:

- 01 . HEATING ELEMENT MATERIAL : KANTHAL BRAND AF GRADE.
- 02 . SIZE OF STRIP : 20mm WIDTH x 1.5mm THICK.
- 03 . NO OF TURNS IN EACH ELEMENT : 23
- 04 . STRETCHED LENGTH OF STRAIGHT STRIP FOR EACH ELEMENT INCLUDING THE TERMINALS OF KANTHAL AF GRADE STRIP ONLY-20.508 METRE.
- 05 . COLD RESISTANCE OF EACH ELEMENT INCLUDING THE TERMINALS - 0.932 OHM.
- 06 . NO OF HEATING ELEMENTS IN THE FURNACE 06 NOS.
- 07 . WEIGHT OF EACH ELEMENT INCLUDING THE TERMINALS - 4.662 KG.
- 08 . CONNECTION DIAGRAM OF HEATING ELEMENTS.

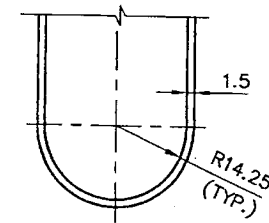

DETAIL - X

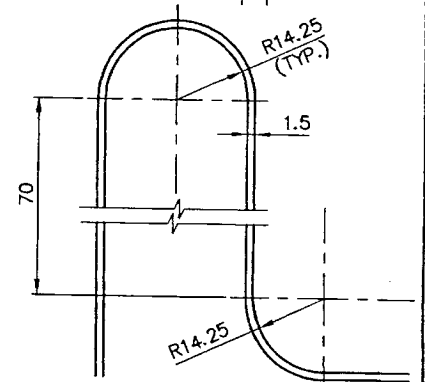

DETAIL - Y



DETAIL - Z

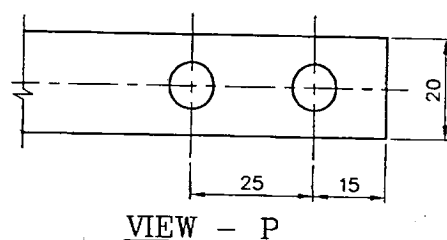
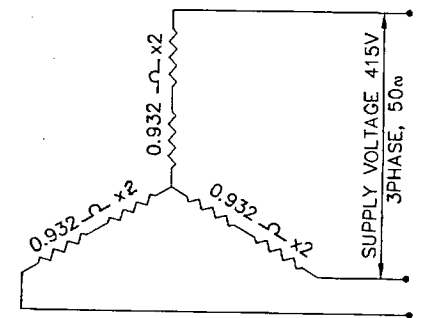

VIEW - P

ENR. Sl. No: 80

04	PL1.5x20x275	KANTHAL	D- GRADE	0.237		02				
01	PL1.5x20x8445	KANTHAL	AF GRADE	4.425		01				
				4.662		04				
No. of Pieces		DESCRIPTION	MATERIAL	STANDARD	NET.WT.IN KGS.	DRAWING No.	ITEM No.			
REFERENCE:		COMPONENT CODE: 00		EQUIPMENT CODE: 03						
SCALE		ALTERATIONS:					DCN REF	DATE	SIGN.	INDEX
1:5 &	DRAWN	A. RAJA								
1:1	CHECKED	R. Ramamurthy								
	APPROVED	[Signature]								
	DATE	09.12.1997								
MACHINE: ELE. CAR BOTTOM FURNACE				TYPE: PRECON-1T-96KW						
TITLE: STRIP ELEMENT				DRAWING No: 18A01			REV.			
				3-M-18C-10987						
No. of Sheets:				Sheet No:						

END. S. No. 100

Caution
THIS DRAWING IS OUR SOLE PROPERTY AND SHOULD NOT BE USED IN ANY FORM FOR ANY OTHER PURPOSE WITHOUT THE WRITTEN PERMISSION OF BHARAT HEAVY ELECTRICALS LTD., TIRUCHIRAPALLI - 620 018.

39-609 A

END. S. No. 100

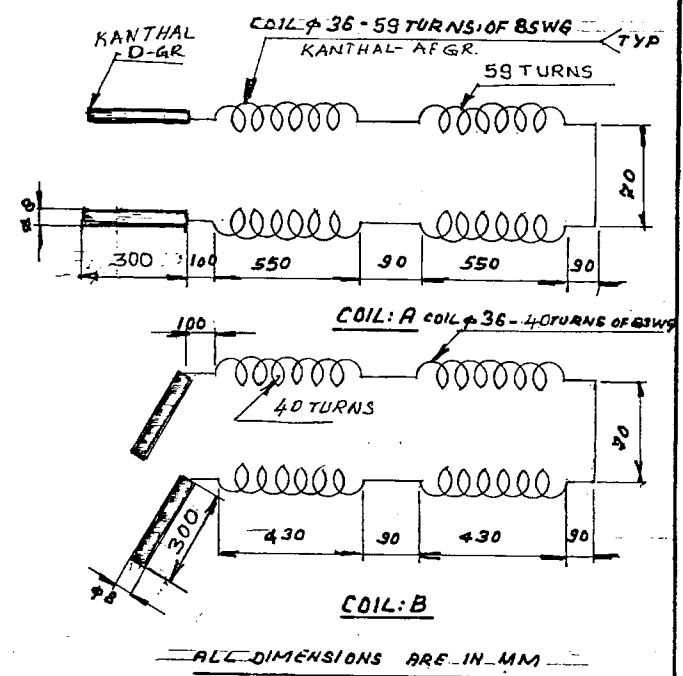
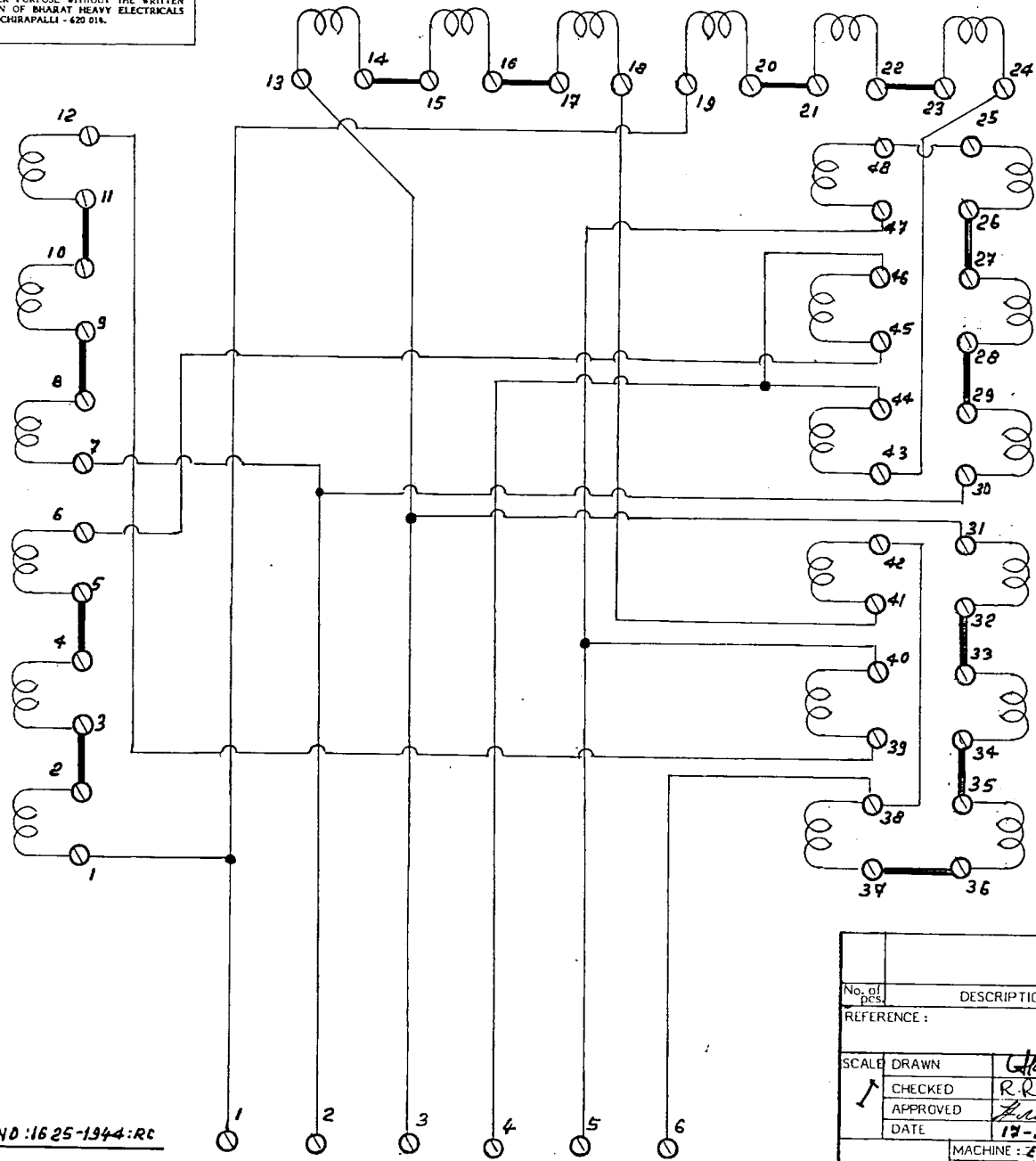

LOC: NO:1625-1944-RC

BAT 5 - BL 4.6

COIL A: 1 TO 36 NO OF COILS : 18

COIL B: 37 TO 48 NO. OF COILS : 6

No. of Pcs.	DESCRIPTION	MATERIAL	STD/BPS	Net wt. (kg)	Gross wt. (kg)	DRAWING No.	Item No.
REFERENCE :		ALTERATIONS		CC-04	CC-46	SCN	DATE
SCALE	DRAWN	GK-P		105			
	CHECKED	R. Ramamurthy					
	APPROVED	[Signature]					
	DATE	17-10-96					
MACHINE : ELE-CAR BOTTOM				TYPE: PRECON-AT 36 KW		Total-wt. (kg)	
TITLE				DRAWING No.		REV.	
HEATING ELEMENT & TERMINAL CONNECTION				3-E-18C-11383			
No. of Sheets:				Sheet No.			

PRE- QUALIFICATION CRITERIA

The BIDDER / VENDOR has to compulsorily meet all the following requirements to get qualified for consideration of the technical offer for the **SPARE HEATING ELEMENTS REQUIRED FOR SPRING ROD HEATING FURNACE**. If the vendor does not qualify as per PRE- QUALIFICATION CRITERIA, the technical offer of such BIDDER(s) / VENDOR(s) offer will not be evaluated.

S. No.	REQUIREMENTS	VENDOR's COMMENTS
1	The Vendor should have previous experience in the field of supply and commissioning of Heating elements for furnace applications.	
2	Previous P.O reference to BHEL or any other Public sector for similar application otherwise the offer will not be considered.	
3	<p>The vendor should submit following details which are necessary for qualifying their offer.</p> <p>a)Name and postal address of the customer/ company where similar materials supplied .</p> <p>b)Name and designation of the contact person of the customer Phone, FAX no and email address of the contact person of the customer.</p> <p>c)Along with Technical offer, the Vendor should submit performance certificate from minimum ONEcustomer for the satisfactory performance of the same, supplied to them in the customers letter head.</p> <p>d)Test certificate should be produced for the raw material supplied. The certificate should be issued by BHEL approved LAB/GOVT.</p> <p>e)BHEL will verify the information provided by the Bidder. In case the information provided by vendor is found to be false / incorrect, the offer shall be rejected.</p>	