



BHARAT HEAVY ELECTRICALS LIMITED

(A Government of India Undertaking)
HIGH PRESSURE BOILER PLANT
PURCHASE DEPARTMENT - FOSSIL BOILERS
THIRUCHIRAPALLI - 620014
TAMILNADU (INDIA)

PHONE :2577629
GRAMS : BHARATELEC
FAX NO: 2520719
E-mail: srchandran@bheltry.co.in
Web:

429-002/A

	Enquiry No 2661400380 - 55	Enquiry Date 05.06.2014	Due Date for Quotation 23.09.2014
Please quote Enquiry No, Date and due date in all correspondences. This is only a request for quotation and not an order			

Item	Description	Unit	Quantity	Delivery Quantity	Schedule Date
10	5 TON TROLLEY ASSEMBLY WITH HOIST AND CT MECHANISM FOR EOT CRANE AS PER THE SPECIFICATIONS AND SCOPE OF WORK IN ANNEXURE-B. VENDOR QUALIFICATION CRITERIA Only those vendors who satisfy the conditions given in ANNEXURE-A will get qualified to participate in the tender.	NO	1.000	1.00	25.08.14

General Note:

GENERAL NOTE:

PLEASE SUBMIT YOUR OFFER IN "TWO PART BID SYSTEM" AS PER ANNEXURE ENCLOSED.

ENCLOSURES:

ANNEXURE II,III,IV,V,VI &VII.

Enclosures:

"LD clause has to be confirmed without fail."

"Payment to vendors will be made only thro E-Payment mode"

The offers should reach us 30 minutes before the time of opening of tenders.
The offers will be opened at 14.30 hrs on the due date of tender in the presence of tenderers who have submitted their offer and who may like to be present for the tender opening.Late and delayed offers are liable to be rejected.

Yours faithfully,
For **BHARAT HEAVY ELECTRICALS LIMITED**

MANAGER / PURCHASE
(FOSSIL BOILERS)
Yours faithfully,

CAPITAL PURCHASE
COMMERCIAL TERMS AND CONDITIONS

1.0 QUOTATIONS

The Bidders shall submit the offer in **TWO INNER ENVELOPES** as indicated below which shall be sealed in one outer envelope.

Envelope I This sealed envelope should contain all the copies of technical bid together with un-priced commercial bid & annexure III. This envelope should be clearly marked **'Part I - Technical and commercial bid'**,

Indicating Enquiry No., Due Date and Address & Reference of the Bidder.

Envelope II This sealed envelope should contain **price as per Annexure-IV format**. This envelope should be clearly marked **"Part II - Price bid"**, indicating **Enquiry No., Due Date and Address & Reference of the Bidder**.

Both the envelopes (Part I & II) shall be put in one cover (**Envelope III**), duly sealed, superscribing as Part I and Part II of Enquiry No., due date of opening and the address and reference of the Bidder

The above offer should reach this office on or before the due date by 14.00 hours (IST). Late offers will not Be considered.

Tender should not be addressed to any individual's name but only by designation to

**SENIOR MANAGER /PURCHASE/ CP & SP/ MM / MFG
BHARAT HEAVY ELECTRICALS LIMITED
HIGH PRESSURE BOILER PLANT
TIRUCHIRAPALLI - 620 014
TAMIL NADU**

Tenders should be free from **CORRECTION AND ERASURES**, Corrections if any, must be attested. All Amounts shall be indicated both in words as well as in figures. Where there is difference between amount quoted in words and figures, amount quoted in words shall prevail.

Offers should be in **ENGLISH** and accompanied by detailed technical literature, catalogue and detailed dimensional drawings in **ENGLISH** or otherwise, the offers will not be considered.

2.0 OPENING OF TENDERS

The Part I - Technical & commercial bid alone would be opened on the Tender opening date.

The Part II - Price bid of technically suitable Bidders alone would be opened. The Technically Suitable Bidders would be informed about the tender opening date through e-mail.

Clarifications if any required by BHEL for Technical evaluation **would be** sought from Bidders before opening of Part II - price bid

For any queries clarifications the bidders may contact us through our FAX NO. +91 431 2520719 or through e-mail < mmcpmfg1@bheltry.co.in > & < chells@bheltry.co.in>

MM: CP & SP

Annexure For Techno Commercial Bid
Check List - to be filled and submitted along with Technical Bid

BHEL Commercial Terms and Conditions for Indigenous Supplies	Vendor's Confirmation / Comments
Technical confirmation to BHEL's Specification as called for in BHEL Format shall be furnished. If needed additional sheets shall be used.	
Prices shall be quoted item wise only as per the model format enclosed	
Prices shall be quoted on " FIRM PRICE " basis only The prices should be only on F.O.R / Despatching station basis with Packing & Forwarding charges if any. Applicable % of ED & Sales Tax, Freight & Insurance, Installation & Commissioning Charges should be clearly Indicated	
Validity of offer shall be for a minimum period of 120 days from the date of Tender opening	
Delivery period from the date of Letter of Intent / Purchase order shall be clearly mentioned in the offer	
Liquidated damages @ '0.5% per week subject to a maximum of 10% of the order value shall be applicable for delay in deliveries For Details Refer Annexure- v	
Following Risk Purchase clause shall be applicable The purchaser at his option will be entitled to terminate the contract and to purchase elsewhere at the risk and cost of the seller either the whole of the goods or any part which the supplier has failed to deliver or dispatch within the time stipulated or if the same were not available, the best and the nearest available substitute therefore The supplier shall be liable for any loss which the Purchaser may sustain by reason of such risk purchases	
Payment term for supply portion: Payment term is 100% direct payment after 45 days from the date of receipt and acceptance of materials For details Refer Annexure- v	
Erection / commissioning: (if applicable only) Erection / commissioning charges if any has been mentioned in the offer or else confirmation that Erection / commissioning shall be done at free of cost is available in the offer,	
The equipment shall be guaranteed for a period of 12 months from the date of commissioning	
Final inspection and acceptance of equipment will be after installation at BHEL, Trichy	
The vendor shall provide necessary drawings, Test Certificates and Operating Maintenance Manuals etc., as called for in the Technical Specification, in the required number of copies at no extra cost	
Any warranty replacement during warranty period shall be supplied free of charge on FOR BHEL, Trichy basis.	
Offers should be submitted only in sealed cover super-scribing clearly the Enquiry reference and due date.	
% of Excise Duty with cess	
% of TAX (CST/VAT)-(INGST with FORM-17 or CST with C-FORM)	
Packing & Forwarding Charges (if any in % only)	
Percentage of Freight& transit insurance charges, if any Freight charges from Dispatching station to BHEL, Tiruchirappalli • Supplier should quote for F.O.R-BHEL Trichy Stores.	
As per Commercial terms and conditions, acceptance for participation in Reverse auction (RA).Yes/No to be indicated	
Name of the person for participating reverse auction	
Land Line Number	
Fax Number	
Mobile Number	
E-mail ID	

NOTE:-

- It is confirmed that all the terms and conditions stipulated in the Enquiry have been fully understood by us and all clarifications & details have been obtained.
- Your offer should be indicating applicable if any P&F Charges, % of ED, Sales Tax -CST or VAT, Service Tax), Freight, Insurance and Installation and Commissioning Charges etc., as per our Price Format
- Your specific acceptance to our Payment terms, LD & Risk Purchase Clause are essential for consideration of your offer. Other wise your offer is liable for rejection.
- No row shall be left blank. Please indicate NA, in case the item is "not applicable"

Payment Term (Indigenous)	
If materials are receivable at Stores/Trichy without PBG	Payment term is 100% direct payment after 45 days from the date of receipt and acceptance of materials.
If materials are receivable at Stores/Trichy with PBG	Payment term is 100% direct payment after 45 days from the date of receipt and acceptance of materials and against 10% PBG valid for the warranty period.
Any deviation in the above payment term will attract loading as mentioned below. “Base rate of SBI (as applicable on the date of bid opening. Techno-commercial bid opening in case of two part bids) + 6% shall be considered for loading for the period of relaxation sought by bidders.	

Payment through Bank is not preferred. In case of Payment through Bank is opted by Supplier, BHEL prefers documents submission through bank with copy of LR and door delivery of Goods to Site/Stores with Consignee copy attached. In this case Loading will be 3% on the offered value.

Offers of indigenous Suppliers with payment terms as LC/Advance Payment are liable for rejection.

Liquidated Damages / Penalty -

Liquidated damages shall be 0.5% of the total order value per week or part thereof subject to a maximum of 10% of the total order value.

For staggered delivery schedule, LD shall be 0.5% of the undelivered portion per week of the delay or part thereof subject to a maximum of 10% of the total order value.

Any deviation from the above LD clause, loading will be applied to the extent to which it is not agreed by the bidder (at offered value).

Guarantee / Warranty Period – (if applicable)

Normally No deviation permitted and the deviated offers are liable for rejection.

Ranking-

BHEL will consider the ranking after the loading is applied as referred above wherever deviations are observed.

Performance Bank Guarantee – (if applicable)

Normally No deviation permitted and the deviated offers are liable for rejection.

NOTE:-

1. If the due date of tender opening happens to be a holiday, the tenders will be opened on the next working day.
2. BHEL reserves the right to go for a reverse auction (RA) instead of opening the submitted sealed bid which will be decided after technical evaluation. Information and general terms and conditions covering RA are given in commercial terms and conditions.
3. Corrigendum if any, with respect to this tender will be hosted only in the website <http://www.bhel.com> or <http://tenders.gov.in>. You are requested to visit the website regularly for updates.

Special Provisions for Micro and Small Enterprises (MSE)

1. 20% of the tendered quantity is earmarked for MSE suppliers in this tender.
2. Out of the 20% tendered quantity reserved for MSE suppliers, 4% shall be earmarked for procurement from MSE owned by SC/ST entrepreneurs.
3. In case MSE vendor participating in the tender quotes within the price band of L1+15%, they will be allowed to supply the portion of the requirement subject to acceptance of L1 price by MSE vendor. In case of more than one such MSE, the supply shall be shared proportionately.
4. "MSE suppliers can avail the intended benefits only if they submit along with the offer, attested copies of either EM II certificate having deemed validity (five years from the date of issue of acknowledgement in EM-II) or valid NSIC certificate or EM II certificate along with attested copy of a CA certificate (Format enclosed at Annexure -VII where deemed validity of EM II certificate of five Years has expired) applicable for the relevant financial year (latest audited). Date to be reckoned for determining the deemed validity will be the date of bid opening (Part 1 in case of two part bid). Non submission of such documents will lead to consideration of their bid at par with other bidders. No benefit shall be applicable for this enquiry if any deficiency in the above required documents are not submitted before price bid opening. If the tender is to be submitted through e-procurement portal, then the above required documents are to be uploaded on the portal. Documents should be notarized or attested by a Gazetted officer."

Certificate by Chartered Accountant on letter head

This is to Certify that M/S
(hereinafter referred to as 'company') having its registered office at
..... is registered under MSMED Act 2006, (Entrepreneur
Memorandum No (Part-II) dtd:.....,
Category: (Micro/Small)). (Copy enclosed).

Further verified from the Books of Accounts that the investment of the company as on
date..... as per MSMED Act 2006 is as follows:

1. **For Manufacturing Enterprises:** Investment in plant and machinery (i.e. original cost
excluding land and building and the items specified by the Ministry of Small Scale Industries vide its
notification No.S.O.1722(E) dated October 5, 2006 :
Rs.....Lacs
2. **For Service Enterprises:** Investment in equipment (original cost excluding land and building and
furniture, fittings and other items not directly related to the service rendered or as may be notified under the MSMED
Act, 2006:
Rs.....Lacs

The above investment of Rs.....Lacs is within permissible limit of
Rs.....Lacs forMicro / Small (Strike off which is not applicable)
Category under MSMED Act 2006.

Date:

(Signature)

Name -

Membership number -

Seal of Chartered Accountant

~~ANNEXURE~~ - B

SPECIFICATION & SCOPE OF WORK		
S.No	Description	Vendor to specify details
	SPECIFICATION FOR 5 T TROLLEY ASSEMBLY WITH HOIST AND CT MECHANISM FOR EOT CRANE	
	APPLICATION: The trolley assembly is required to replace in the existing Indoor EOT crane.	
1	SCOPE OF SUPPLY: Trolley assembly with hoist mechanism	
1.0	CT mechanism detail:	
1.1	CT speed:15 m/min	
1.2	Wheel gauge / span: 2000 mm	
1.3	Wheel base:1600 mm	
1.4	Wheel size:250 mm dia- 4 Nos	
1.5	CT rail size: 50mm Square bar (For reference only. Not supplier scope)	
1.6	Wheel assembly: As per BHEL drawing 3M02R0011993 (Enclosed).	
1.7	CT Gear box type & size: Vertical VR 320 – 1 No. (All the gears shall be helical)	
1.8	CT Motor (1 No): 2.4 kw(min), 6 pole, 3Ph 415V 50hz, 150 starts/hour Duty Factor – 40% CDF	
1.9	Type of CT motor: Squirrel Cage	
1.10	CT BRAKE: 160 mm 18 KG thruster brake with brake drum – 1 No	
1.11	Couplings: Between motor & gearbox- Full gear coupling. Between gearbox & wheel - Half gear coupling	
1.12	Limit Switch: Lever type one no.	
2.0	HOIST MECHANISM DETAIL:	
2.1	Hoist speed:15m/min	
2.2	Height of lift: 8 mtr	
2.3	Hoist Motor (1 No): 14.7 kw (min), 6 pole, 3Ph 415V 50 hz, 150 starts/hour Duty Factor: 40% CDF	
2.4	Hoist Motor type: Squirrel cage	
2.5	Gear box size: Horizontal HR500 – 1 No (All the gears shall be helical)	
2.6	Hoist rope size & falls: 12mm dia 4 falls. Sufficient rope for 8m height of lift to be supplied.	
2.7	Hook shall be with safety latch.	
2.8	Hoist rope drum size: 320mm dia. On both ends of rope drum, flange to be provided to a height of 100mm	
2.9	Couplings: Between motor & gearbox- Full gear coupling Between gearbox & rope drum- Half geared rope drum coupling or spline.	
2.10	Pulley Sizes: Equaliser Pulley – 200 mm dia	

Handwritten signature
04/03/14

	Hook Block Pulleys – 320 mm dia	
2.11	Hook Block: 5 Ton Hook Block	
2.12	Hoist Brake: 250 mm dia DC Electromagnetic Brake with brake drum – 1 No	
2.13	Limit Switches: Rotary and Gravity each one no to be provided	
3.0	MAKES OF BOUGHT-OUT ITEMS	
3.1	Motors: GEC/Bharat Bijlee/Siemens/KEC/MARATHON	
3.2	Couplings: WMI/ALFLEX/FENNER	
3.3	Electrohydraulic thruster Brakes: OMEGA/ELECTROMAG/SPEED-O-CONTROL	
3.4	DCEM Brake & Brake Panel: Only BCH	
3.5	Limit Switches: BCH/SKC/SOC	
3.6	Oil Seals: PARKER /MERKEL/ SIMRIT FREDENBERG/ BUSHAK SHAMBAN/ HUNGER/ HALLITE/ JAMES WALKER /SKF ECONOMOS	
4.0	Both gearbox casing shall be of fabricated type and gears in all stage shall be of helical	
4.1	Handrails to 1m height & Spring Buffer (4 Nos) are to be provided in the CT Trolley.	
4.2	Standard to be followed IS: 3177/1999 & IS: 807.	
4.3	Painting of trolley frame: 1. One coat of red oxide with 48 hours of curing after painting. 2. Two coats of Deep orange enamel paint with intermittent curing of minimum 16 hours.	
4.4	Pre-dispatch Inspection shall be offered.	
4.5	The following drawing to be submitted for approval before manufacture. 1. Crab Frame 2. CT wheel Assembly 3. CT Gearbox Assembly 4. CT Mechanism Assembly 5. Hoist Gearbox Assembly 6. Rope drum 7. 5 Ton Hook Assembly 8. GA drawing of Trolley Assembly	
4.6	Spares: The following spares to be provided along with supply 1. Oil Seals – 1 No. of each variety used in the trolley assembly.	
4.7	Note: No electrical control panel required	

Handwritten signature
04/03/14

ANNEXURE-A (VENDOR QUALIFICATION CRITERIA)

The BIDDER / VENDOR has to compulsorily meet all the following requirements to get qualified for consideration of the technical offer for the **SUPPLY OF TROLLEY ASSEMBLY FOR 5 TON EOT CRANE**. If the vendor does not qualify as per VENDOR- QUALIFICATION CRITERIA, the technical offer of such BIDDER(s) / VENDOR(s) offer will not be evaluated.

S. No.	REQUIREMENTS	VENDOR's COMMENTS
1	The BIDDER(s) / VENDOR(s) shall be a Manufacturer (OEM) of EOT cranes.	
2	The BIDDER(s) / VENDOR(s) shall have a minimum five years of Continuous Experience in supplying EOT Cranes. The BIDDER / VENDOR should necessarily attach Certificate of Incorporation/ Deed of partnership/Certification of registration or any other documents supporting the above experience.	
3	Along with Technical offer, the Vendor should submit performance certificate from minimum one customer for the satisfactory performance of double girder EOT Crane of minimum 5 ton capacity supplied to them in the customer's letter head.	
4	The supplier has to submit the original test certificate for the items from the Manufacturer at the time of supply of the materials.	
5	Any Deviations in technical specification may lead to rejection of the offer.	
6	Along with the offer the Vendor should submit a reference List of Customers to whom similar items have been supplied along with the details (Name, Designation, Phone Number ,E-Mail ID) of the CONTACT PERSON of the customer	
7	BHEL reserves the right to verify the information provided by vendor. In case the information provided by vendor is found to be false / incorrect, the offer shall be rejected.	

04/03/14

CAUTION: THIS DRAWING IS OUR SOLE PROPERTY AND SHOULD NOT BE USED IN ANY FORM FOR ANY PURPOSE WITHOUT THE WRITTEN PERMISSION OF BHARAT HEAVY ELECTRICALS LIMITED TRICHIRAPPALLI - 620 024.

ALL DIMENSIONS ARE IN MM

SL. No.	O.D. (WHEEL DIA) IN MM	RAIL SIZE	DIMENSIONS													COUPLING No.	SHEF BRG No.	TOTAL WEIGHT IN Kg. FOR DRIVE & IDLE				
			A	B	D	E	F	ØG	H	ØJ	K	L	Ød	M (KEY)	N				P	Q	S	R
16	800/850	CR-100 CR-120	190	450	80	210	150	152	140	130	212	255	32	32x18x130	687	588	20	150	80	107	22330	870.00
15		CR-80	168	420	80	180	110	152	125	110	212	255	32	28x16x115	667	588	20	150	80	106	22330	845.00
14		CR-100 CR-120	190	450	80	210	150	152	140	130	212	255	32	32x18x130	642	588	20	150	80	107	22330	796.00
13	710/750	CR-100 CR-120	180	420	71	210	150	132	125	110	180	224	32	28x16x115	607	517	20	130	80	106	22326	775.00
12		CR-80	180	400	71	180	110	132	125	110	180	224	32	28x16x115	607	517	20	130	80	106	22326	728.00
11		CR-80/CR-100 CR-120	180	420	71	210	150	132	125	110	180	224	32	28x16x115	567	517	20	130	80	106	22326	711.50
10	630/680	CR-80/CR-100 CR-120	150	365	60	180	105	111	110	90	160	190	26	25x14x100	547	462	20	120	60	105	22322	653.00
9		CR-80 CR-100	160	375	60	180	125	111	110	90	160	190	26	22x14x100	482	462	20	120	60	105	22322	628.00
8	500/550	CR-80	150	360	50	180	125	91	105	80	125	160	26	22x14x90	445	395	20	100	50	104	22318	611.50
7		CR-75/90 & 105 Lm/7d	150	360	50	180	105	91	105	80	125	160	26	22x14x90	445	395	20	100	50	104	22318	588.00
6	400/450	CR-80	150	360	50	180	125	91	105	80	125	160	26	22x14x90	395	395	20	100	50	104	22318	501.00
5		75 / 90 & 105 Lm/7d	145	315	40	180	105	76	85	70	112	140	22	20x12x75	375	345	16	90	50	103	22315	294.00
4	320/370	50 SQUARE CR-80	145	315	40	180	105	76	85	70	112	140	22	20x12x75	345	345	16	90	50	103	22315	245.50
3		50 SQUARE CR-80	112.5	260	40	125	85	61	65	55	85	112	17	16x10x55	312	287	16	80	50	102	22312	197.00
2	250/280	50 SQUARE CR-80	105	250	32	125	85	61	65	55	76	100	17	16x10x55	254	249	12	60	40	102	22312	162.00
1	200/230	50 SQUARE CR-80	95	220	32	100	67	46	55	40	71	95	17	12x8x45	239	232	12	65	40	101	22309	157.00

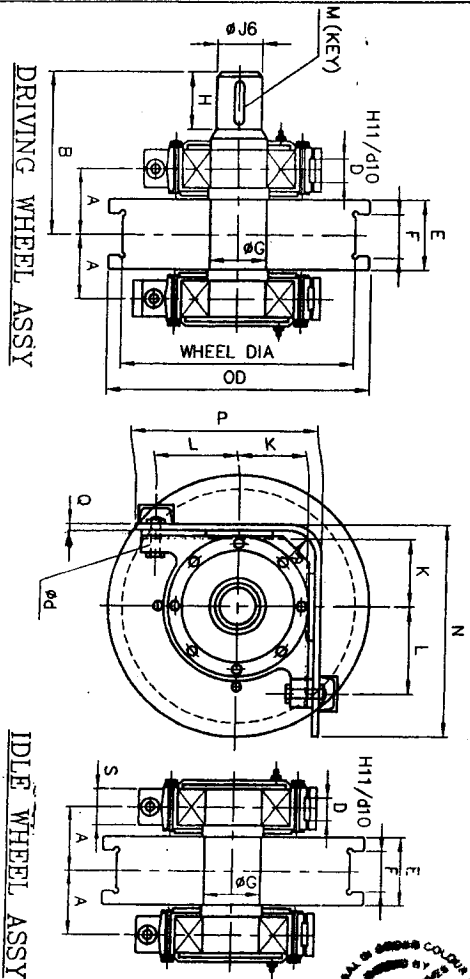

MATERIAL:
SHAFT - 45CB/15122B5.
WHEEL - 55CB/1515B15.
TREAD PORTION WHEEL HARDNESS 500 TO 550 (BHN)

<p>SCALE: DRAWN: [Signature] CHECKED: [Signature] APPROVED: [Signature] DATE: 20-10-2000</p>	<p>DESCRIPTION: STANDARD CRANE WHEEL ASSY</p>	<p>MATERIAL: 45CB/15122B5</p>	<p>STANDARD COMPONENT CODE: 29</p>	<p>NET WT IN KGS: 22330</p>	<p>DRAWING No. 3-M-02R-11993</p>
<p>TITLE: STANDARD CRANE WHEEL ASSY</p>	<p>TYPE: GENERAL</p>	<p>DRIVING No. 00</p>	<p>REVISION: 00</p>	<p>DATE: 20-10-2000</p>	<p>REV.:</p>