



429-002/A

BHARAT HEAVY ELECTRICALS LIMITED

(A Government of India Undertaking)
HIGH PRESSURE BOILER PLANT
PURCHASE DEPARTMENT - FOSSIL BOILERS
THIRUCHIRAPALLI - 620014
TAMILNADU (INDIA)

Page
1/2
PHONE :2577629
GRAMS : BHARATELEC
FAX NO: 2520719
E-mail: srchandran@bheltry.co.in
Web:

Enquiry No	Enquiry Date	Due Date for Quotation
2661400702 - 55	23.09.2014	18.10.2014
Please quote Enquiry No, Date and due date in all correspondences. This is only a request for quotation and not an order		

Item	Description	Unit	Quantity	Delivery Quantity	Schedule Date
10	7519A2300200 BOTTOM PULLEY ASSEMBLY AS PER DRAWING NO. 2-M-19A23-05147 AND ITS SUB DRAWING NO. 2-M-19A23-05146, 3-M-19A23-15250, 4-M-19A23-29787. COMMON NOTE FOR ALL ITEMS: After placement of Purchase order 1 No of Sample in each items shall be supplied preferably within 6 weeks to BHEL acceptance. After getting acceptance from BHEL full quantity may be supplied. Acceptance from BHEL will be given within 1 week.This period (6+2=8 weeks)taken into account while quoting delivery period by the supplier. VENDOR QUALIFYING CRITERIA: Only those vendors who satisfy the following conditions will get qualified to participate in the tender: 1. Vendor should have minimum 2 years of experience in this field. 2. Previous PO details for supplying similar kind of items to BHEL and / or any-other Organisation should be submitted along with offer. Otherwise offer will be rejected. 3. Company profile details has to be provided along with offer. 4. BHEL reserves the right to visit the vendor's works for verifying the manufacturing facilities and any other credential furnished by the vendor. In case the information furnished with the offers found to be false / incorrect, the offer shall be rejected.	NO	2.000	2.00	27.01.15
20	7512B2500700 BASE JAW AS PER DRG. NO. 2-M-12B25-05152-02 NOTE: FOR SL.NO 20 TO 40 ARE MATING COMPONNETS AND HENCE THESE ITEMS SHOULD BE PROCURED FROM SINGLE SOURCE ONLY.	NO	10.000	10.00	27.01.15

The offers should reach us 30 minutes before the time of opening of tenders.
The offers will be opened at 14.30 hrs on the due date of tender in the presence of tenderers who have submitted their offer and who may like to be present for the tender opening.Late and delayed offers are liable to be rejected.

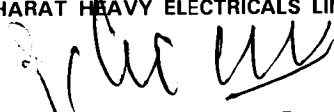
Yours faithfully,
For **BHARAT HEAVY ELECTRICALS LIMITED**

MANAGER / PURCHASE
(FOSSIL BOILERS)
Yours faithfully,



BHARAT HEAVY ELECTRICALS LIMITED

(A Government of India Undertaking)
HIGH PRESSURE BOILER PLANT
PURCHASE DEPARTMENT - FOSSIL BOILERS
THIRUCHIRAPALLI - 620014
TAMILNADU (INDIA)

Page
2/2

PHONE :2577629
GRAMS : BHARATELEC
FAX NO: 2520719
E-mail: srchandran@bheltry.co.in
Web:

2661400702 / 23.09.2014

30	7512B4900300 JAWS AS PER DRG. NO. 2-M-12B49-05228-01	NO	15.000	15.00	27.01.15
40	7512B4900400 JAWS GRIPPING PAD AS PER DRG. NO. 2-M-12B49-05229-01	NO	20.000	20.00	27.01.15
50	7519A2300300 ROLLER ASSEMBLY AS PER DRAWING NO. 2-M-19A23-05161 AND ITS SUB DRAWING NO. 2-M-19A23-05162, 2-M-19A23-05163.	NO	10.000	10.00	27.01.15
60	7512B1700700 TRUNNION AS PER DRG.NO. 4-M-12B17/18-10698-01	NO	50.000	50.00	27.01.15

General Note:

GENERAL NOTE:PLEASE SUBMIT YOUR OFFER IN "TWO PART BID SYSTEM" AS PER THE ANNEXURES ENCLOSED.
ENCLOSURES : ANNEXURES II,III,IV,V,VI,VII AND DRAWINGS.

Enclosures:

"LD clause has to be confirmed without fail."

The offers should reach us 30 minutes before the time of opening of tenders.
The offers will be opened at 14.30 hrs on the due date of tender in the presence of tenderers who have submitted their offer and who may like to be present for the tender opening.Late and delayed offers are liable to be rejected.

Yours faithfully,
For BHARAT HEAVY ELECTRICALS LIMITED

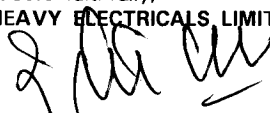
MANAGER / PURCHASE
(FOSSIL BOILERS)
Yours faithfully,

CAPITAL PURCHASE
COMMERCIAL TERMS AND CONDITIONS

1.0 QUOTATIONS

The Bidders shall submit the offer in **TWO INNER ENVELOPES** as indicated below which shall be sealed in one outer envelope.

Envelope I This sealed envelope should contain all the copies of technical bid together with un-priced commercial bid & annexure III. This envelope should be clearly marked **'Part I - Technical and commercial bid'**,

Indicating Enquiry No., Due Date and Address & Reference of the Bidder.

Envelope II This sealed envelope should contain **price as per Annexure-IV format**. This envelope should be clearly marked **"Part II - Price bid"**, indicating **Enquiry No., Due Date and Address & Reference of the Bidder**.

Both the envelopes (Part I & II) shall be put in one cover (**Envelope III**), duly sealed, superscribing as Part I and Part II of Enquiry No., due date of opening and the address and reference of the Bidder

The above offer should reach this office on or before the due date by 14.00 hours (IST). Late offers will not be considered.

Tender should not be addressed to any individual's name but only by designation to

**SENIOR MANAGER /PURCHASE/ CP & SP/ MM / MFG
BHARAT HEAVY ELECTRICALS LIMITED
HIGH PRESSURE BOILER PLANT
TIRUCHIRAPALLI - 620 014
TAMIL NADU**

Tenders should be free from **CORRECTION AND ERASURES**, Corrections if any, must be attested. All Amounts shall be indicated both in words as well as in figures. Where there is difference between amount quoted in words and figures, amount quoted in words shall prevail.

Offers should be in **ENGLISH** and accompanied by detailed technical literature, catalogue and detailed dimensional drawings in **ENGLISH** or otherwise, the offers will not be considered.

2.0 OPENING OF TENDERS

The Part I - Technical & commercial bid alone would be opened on the Tender opening date.

The Part II - Price bid of technically suitable Bidders alone would be opened. The Technically Suitable Bidders would be informed about the tender opening date through e-mail.

Clarifications if any required by BHEL for Technical evaluation **would be** sought from Bidders before opening of Part II - price bid

For any queries clarifications the bidders may contact us through our FAX NO. +91 431 2520719 or through e-mail <mmcpmfg1@bheltry.co.in >&< chells@bheltry.co.in>

Annexure For Techno Commercial Bid

Check List - to be filled and submitted along with Technical Bid

BHEL Commercial Terms and Conditions for Indigenous Supplies	Vendor's Confirmation / Comments
Technical confirmation to BHEL's Specification as called for in BHEL Format shall be furnished. If needed additional sheets shall be used.	
Prices shall be quoted item wise only as per the model format enclosed	
Prices shall be quoted on " FIRM PRICE " basis only The prices should be only on F.O.R / Despatching station basis with Packing & Forwarding charges if any. Applicable % of ED & Sales Tax, Freight & Insurance, Installation & Commissioning Charges should be clearly Indicated	
Validity of offer shall be for a minimum period of 120 days from the date of Tender opening	
Delivery period from the date of Letter of Intent / Purchase order shall be clearly mentioned in the offer	
Liquidated damages @ '0.5% per week subject to a maximum of 10% of the order value shall be applicable for delay in deliveries For Details Refer Annexure- v	
Following Risk Purchase clause shall be applicable The purchaser at his option will be entitled to terminate the contract and to purchase elsewhere at the risk and cost of the seller either the whole of the goods or any part which the supplier has failed to deliver or dispatch within the time stipulated or if the same were not available, the best and the nearest available substitute therefore The supplier shall be liable for any loss which the Purchaser may sustain by reason of such risk purchases	
Payment term for supply portion: Payment term is 100% direct payment after 45 days from the date of receipt and acceptance of materials For details Refer Annexure- v	
Erection / commissioning: (if applicable only) Erection / commissioning charges if any has been mentioned in the offer or else confirmation that Erection /commissioning shall be done at free of cost is available in the offer,	
The equipment shall be guaranteed for a period of 12 months from the date of commissioning	
Final inspection and acceptance of equipment will be after installation at BHEL, Trichy	
The vendor shall provide necessary drawings, Test Certificates and Operating Maintenance Manuals etc., as called for in the Technical Specification, in the required number of copies at no extra cost	
Any warranty replacement during warranty period shall be supplied free of charge on FOR BHEL, Trichy basis.	
Offers should be submitted only in sealed cover super-scribing clearly the Enquiry reference and due date.	
% of Excise Duty with cess	
% of TAX (CST/VAT) (INGST with FORM-17 or CST with C-FORM)	
Packing & Forwarding Charges (if any in % only)	
Percentage of Freight& transit insurance charges, if any Freight charges from Dispatching station to BHEL, Tiruchirappalli • Supplier should quote for F.O.R-BHEL Trichy Stores.	
As per Commercial terms and conditions, acceptance for participation in Reverse auction (RA). Yes/No to be indicated	
Name of the person for participating reverse auction	
Land Line Number	
Fax Number	
Mobile Number	
E-mail ID	

NOTE:-

- It is confirmed that all the terms and conditions stipulated in the Enquiry have been fully understood by us and all clarifications & details have been obtained.
- Your offer should be indicating applicable If any P&F Charges, % of ED, Sales Tax -CST or VAT, Service Tax), Freight, Insurance and Installation and Commissioning Charges etc., as per our Price Format
- Your specific acceptance to our Payment terms, LD & Risk Purchase Clause are essential for consideration of your offer. Other wise your offer is liable for rejection.
- No row shall be left blank. Please indicate NA, in case the item is "not applicable"

Annexure For Price Bid

Bharat Heavy Electricals Limited TIRUCHIRAPPALLI CAPITAL PURCHASE
MODEL PRICE BID FORMAT FOR INDIAN BIDDERS

Annexure-IV

Enquiry No. & Date:

Bidder's Offer No. & Date:

SI No	Description of item	Unit	Quantity	Rate in Rs.	Value in Rs.
	TOTAL VALUE IN RS.				
	Packing & Forwarding charges in % if any				
	Freight & Insurance Charges In % if freight charges are not mentioned it will be considered as FOR-BHEL TRICHY.				
	Excise Duty (indicate in %)				
	A) TNGST — VAT (%)				
	B) CST with C-FORM — (%)				
	C) CST without C-Form — (%)				
	Approximate Net weight of the total consignment				
	Approximate Gross weight of the total consignment				
	Approximate Dimensions of the Consignment				
	The price indicated shall be inclusive of all accessories, spares etc. as given in the scope of supply. Individual item-wise break-up price shall be attached as an annexure to this price bid format.				

Signature & Seal of Vendor

NOTE:

1. The price bid should be submitted only as per the above format. No row shall be left blank. Please indicate NA, in case the item is "not applicable".
2. Prices shall be quoted item-wise only as per the above format.
3. If Price quoted is Inclusive of ED, the included ED Value and Base Value shall be indicated item-wise.

Payment Term (Indigenous)	
If materials are receivable at Stores/Trichy without PBG	Payment term is 100% direct payment after 45 days from the date of receipt and acceptance of materials.
If materials are receivable at Stores/Trichy with PBG	Payment term is 100% direct payment after 45 days from the date of receipt and acceptance of materials and against 10% PBG valid for the warranty period.
Any deviation in the above payment term will attract loading as mentioned below. "Base rate of SBI (as applicable on the date of bid opening. Techno-commercial bid opening in case of two part bids) + 6% shall be considered for loading for the period of relaxation sought by bidders.	

Payment through Bank is not preferred. In case of Payment through Bank is opted by Supplier, BHEL prefers documents submission through bank with copy of LR and door delivery of Goods to Site/Stores with Consignee copy attached. In this case Loading will be 3% on the offered value.
Offers of indigenous Suppliers with payment terms as LC/Advance Payment are liable for rejection.

Liquidated Damages / Penalty -
Liquidated damages shall be 0.5% of the total order value per week or part thereof subject to a maximum of 10% of the total order value.
For staggered delivery schedule, LD shall be 0.5% of the undelivered portion per week of the delay or part thereof subject to a maximum of 10% of the total order value.
Any deviation from the above LD clause, loading will be applied to the extent to which it is not agreed by the bidder (at offered value).

Guarantee / Warranty Period – (if applicable)
Normally No deviation permitted and the deviated offers are liable for rejection.

Ranking-
BHEL will consider the ranking after the loading is applied as referred above wherever deviations are observed.

Performance Bank Guarantee – (if applicable)
Normally No deviation permitted and the deviated offers are liable for rejection.

NOTE:-

1. If the due date of tender opening happens to be a holiday, the tenders will be opened on the next working day.
2. BHEL reserves the right to go for a reverse auction (RA) instead of opening the submitted sealed bid which will be decided after technical evaluation. Information and general terms and conditions covering RA are given in commercial terms and conditions.
3. Corrigendum if any, with respect to this tender will be hosted only in the website <http://www.bhel.com> or <http://tenders.gov.in>. You are requested to visit the website regularly for updates.

Special Provisions for Micro and Small Enterprises (MSE)

1. 20% of the tendered quantity is earmarked for MSE suppliers in this tender.
2. Out of the 20% tendered quantity reserved for MSE suppliers, 4% shall be earmarked for procurement from MSE owned by SC/ST entrepreneurs.
3. In case MSE vendor participating in the tender quotes within the price band of L1+15%, they will be allowed to supply the portion of the requirement subject to acceptance of L1 price by MSE vendor. In case of more than one such MSE, the supply shall be shared proportionately.
4. "MSE suppliers can avail the intended benefits only if they submit along with the offer, attested copies of either EM II certificate having deemed validity (five years from the date of issue of acknowledgement in EM-II) or valid NSIC certificate or EM II certificate along with attested copy of a CA certificate (Format enclosed at Annexure -VII where deemed validity of EM II certificate of five Years has expired) applicable for the relevant financial year (latest audited). Date to be reckoned for determining the deemed validity will be the date of bid opening (Part 1 in case of two part bid). Non submission of such documents will lead to consideration of their bid at par with other bidders. No benefit shall be applicable for this enquiry if any deficiency in the above required documents are not submitted before price bid opening. If the tender is to be submitted through e-procurement portal, then the above required documents are to be uploaded on the portal. Documents should be notarized or attested by a Gazetted officer."

Certificate by Chartered Accountant on letter head

This is to Certify that MIS
(hereinafter referred to as 'company') having its registered office at
..... is registered under MSMED Act 2006, (Entrepreneur
Memorandum No (Part—II) dtd.....
Category:,.....,,..... (Micro/Small)). (Copy enclosed).

Further verified from the Books of Accounts that the investment of the company
as per the latest audited financial year as per MSMED Act 2006 is as follows:

For Manufacturing enterprises: Investment in plant and machinery (i.e original cost
excluding land and building and the items specified by the Ministry of Small Scale Industries vide its
notification No.S.0,1722(E) dated October 6. 2006:

Rs. Lacs

2. **For Service Enterprises:** Investment in equipment (original cost excluding land and building and
furniture, fittings and other items not directly related to the service rendered Or as may be notified under the
MSMED Act, 2006.

Rs. Lacs

(Strike off whichever is not applicable)

The above investment of Rs Lacs is within permissible limit of
Rs Lacs for Micro I 6mall (Strike off which is not applicable)
Category under MSMED Act 2006.

Or

The company has been graduated from its original category (Micro/ Small) (Strike off which is not
applicable) and the date of graduation of such enterprise from its original category is
(dclimmiyyyy) which is within the period of 3 years from the date of graduation of such
enterprise from its original category as notified vide S.D. No. 3322(E) dated 01.11.2013
published in the gazette notification dated 04.11.2013 by Ministry of MSME.

Date:

(Signature)

Name -

Membership number -

Seal of Chartered Accountant

2M19A2305147

DRAWING NO:

ALL DIMENSIONS ARE IN MILLIMETERS

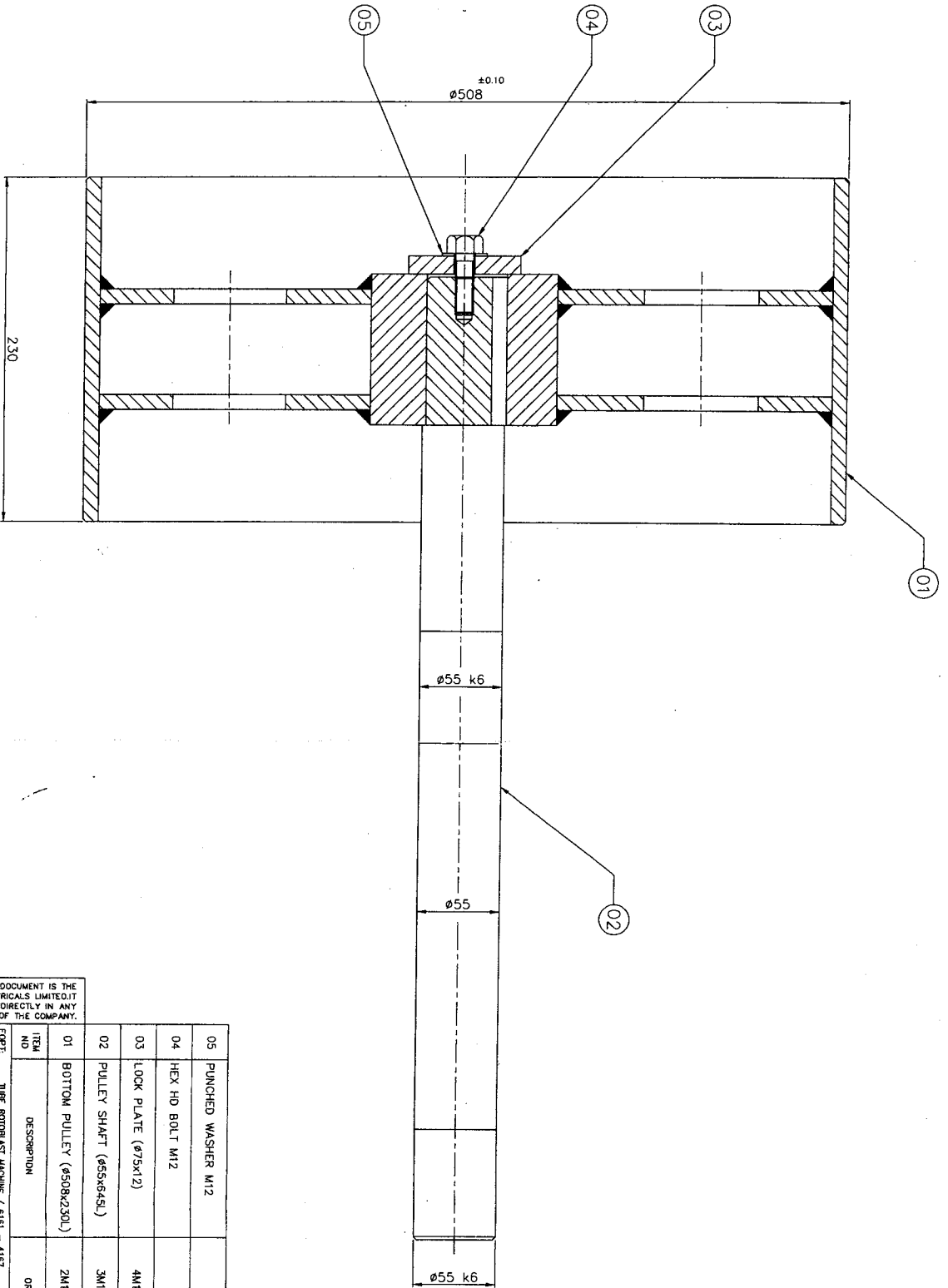

CAUTION: THE INFORMATION ON THIS DOCUMENT IS THE PROPERTY OF BHARAT HEAVY ELECTRICALS LIMITED. IT MUST NOT BE USED DIRECTLY OR INDIRECTLY IN ANY WAY DETRIMENTAL TO THE INTEREST OF THE COMPANY.

ITEM NO	DESCRIPTION	DRAWING NO	MATL SPEC	UNIT	QTY
01	BOTTOM PULLEY ($\phi 508 \times 230$)	2M19A2305146	SA 335 P22	1	59.62
02	PULLEY SHAFT ($\phi 55 \times 645$)	3M19A2315250	SA 105	1	11.71
03	LOCK PLATE ($\phi 75 \times 112$)	4M19A2329787	E 250 A	1	0.40
04	HEX HD BOLT M12		IS 2062	1	
05	PUNCHED WASHER M12			1	

DEPT: TUBE ROTORBLAST MACHINE / 6181 - 4187
 TITLE: BOTTOM PULLEY ASSY. (BUCKET ELEVATOR)
 SCALE: 1:2
 WEIGHT (KG): 71.73
 DATE: 19/03/14
 DRAWING NO: 2M19A2305147



DRAWING NO. 2M12B2505152

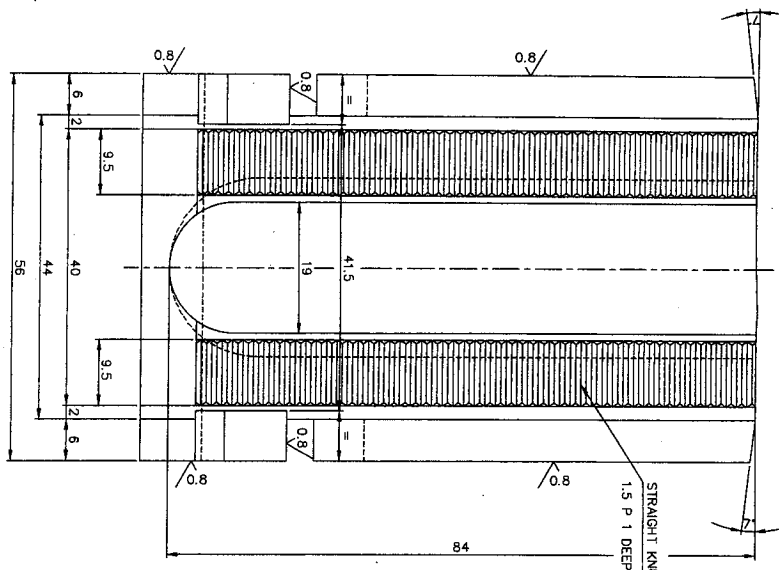
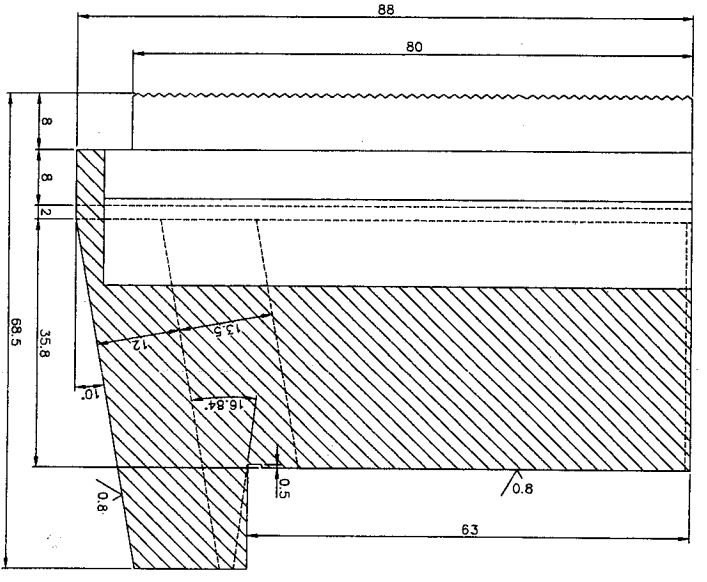
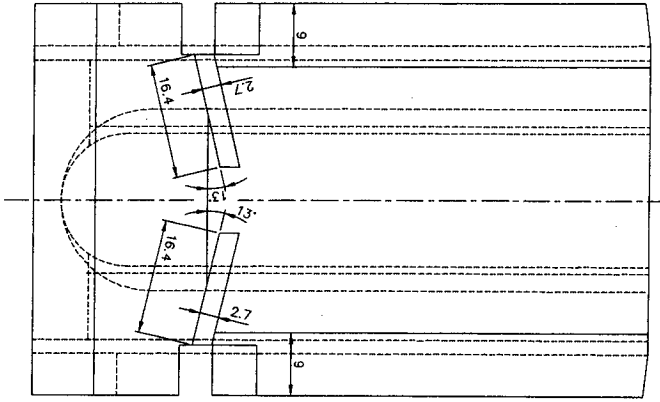

S.L. NO.	MATERIAL	PERCENTAGE
1	C	0.596
2	SI	0.323
3	Mn	0.492
4	P	<0.010
5	S	0.020
6	Cr	0.726
7	Mo	0.108
8	Ni	2.996
9	V	<0.020
10	Al	0.026
11	Cu	0.170

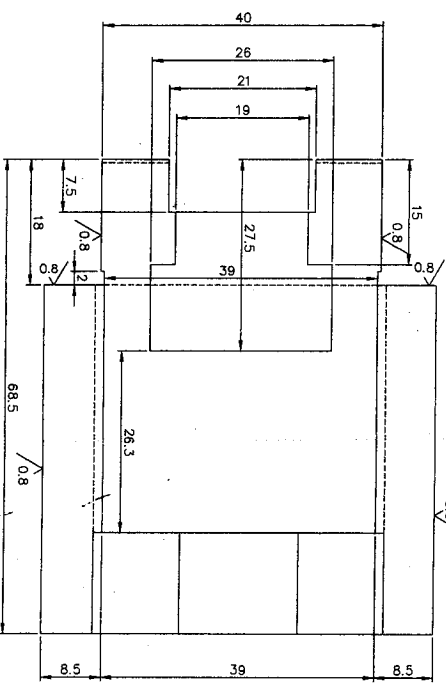

NOTE:
ALL SHARP CORNERS TO BE REMOVED 2/45°
HARDNESS HRc 32

CAUTION: THE INFORMATION ON THIS DOCUMENT IS THE PROPERTY OF SHARAT HEAVY ELECTRICALS LIMITED. IT MUST NOT BE USED DIRECTLY OR INDIRECTLY IN ANY WAY DETRIMENTAL TO THE INTEREST OF THE COMPANY.

SHARAT Bharti Heavy Electricals Ltd HIGH PRESSURE BOILER PLANT THRUCHIRAPALLI - 520014 APJYO KRAMAMANI	88x68 5x56 DESCRIPTION AUTO TUBE END CUTTING & PREPARATION MACHINE DRAWING NO. EN 36 MATL. SPEC. MATL. CODE 1 UNIT WT. 2.64	21 SCALE WEIGHT (KG) 2.64 REF TO ASSY/DWG NO. REF TO QTY/DWG NO.	2M12B2505152 DRAWING NO. REV
---	--	---	------------------------------------



32/0.8
ALL DIMENSIONS ARE IN MILLIMETERS

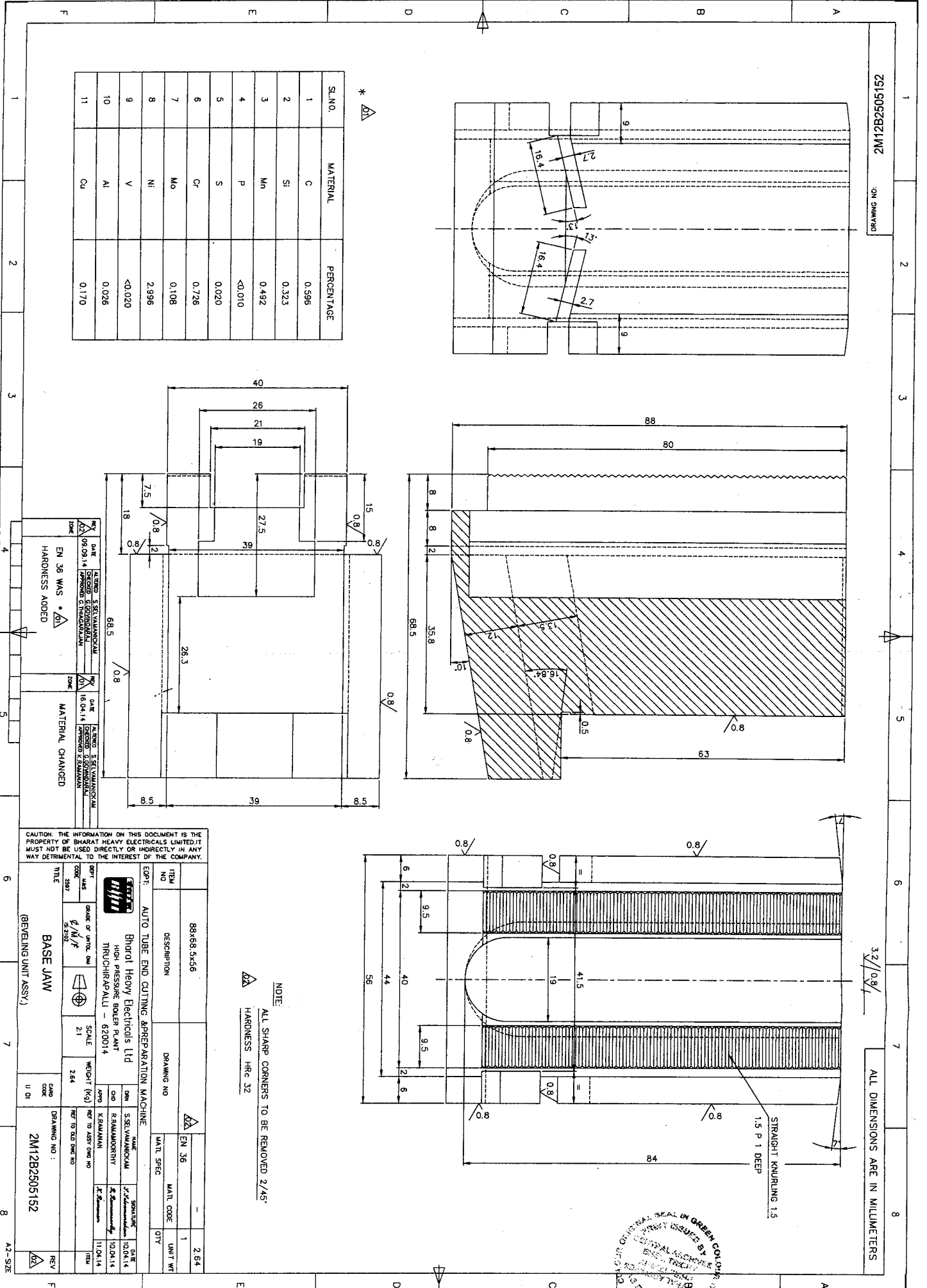

DRAWING NO: 2-M-12B49-05228

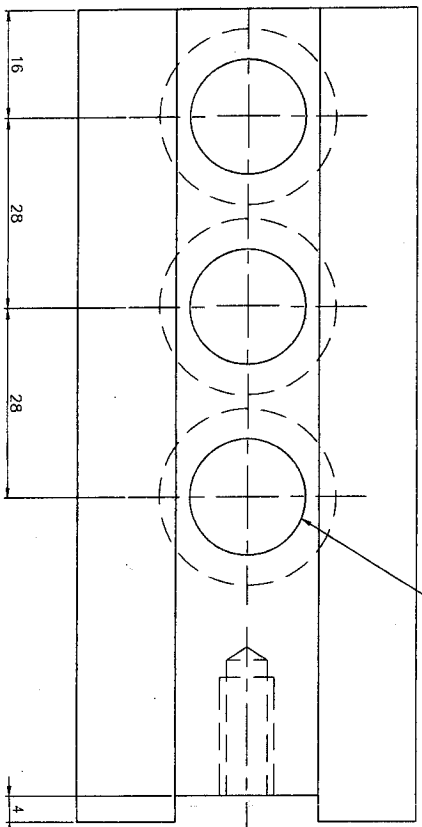
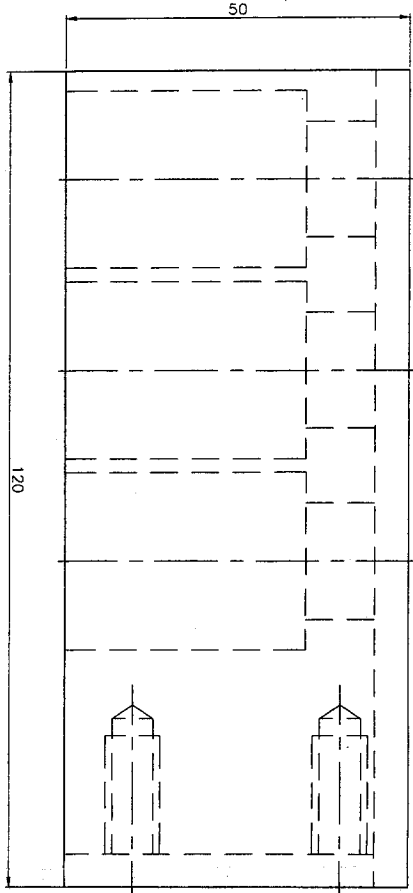

3 HOLES $\phi 17$ / CBR $\phi 26$ X 35 DEEP

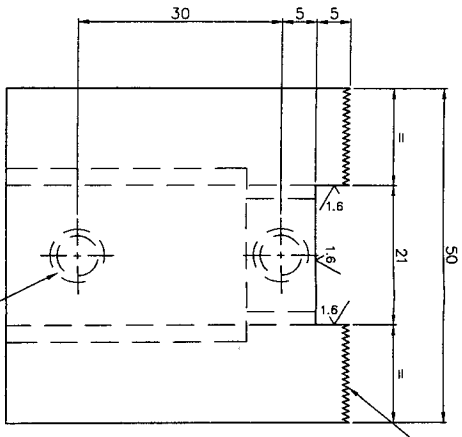

STRAIGHT KNURLING
1.5P X 1 DEEP

M8 X 20 DEEP
(2 NOS)

3.2 / 1.6 ALL DIMENSIONS ARE IN MILLIMETERS

NOTE:
1. DRAWING IS REFERENCE ONLY
2. MANUFACTURING OF THE COMPONENT TO BE DONE ONLY AFTER STUDYING THE ASSEMBLY PHYSICALLY.



CAUTION: THE INFORMATION ON THIS DOCUMENT IS THE PROPERTY OF BHARAT HEAVY ELECTRICALS LIMITED. IT MUST NOT BE USED DIRECTLY OR INDIRECTLY IN ANY WAY DETRIMENTAL TO THE INTERESTS OF THE COMPANY.

REV	DATE	BY	CHKD	APPROVED	REVISION
01	09/08/14	CHANDRAN	CHANDRAN	CHANDRAN	EN 36 WAS E 250 A

DEPT	CODE	DATE	SCALE	WEIGHT (Kg)	PER TO STD DRW NO
2307			2:1	2.70	

ITEM NO	DESCRIPTION	DRAWING NO	MATL SPEC	MATL CODE	QTY
IS 1730	PL 50 X 50 X 120L	EN 36			1

DATE	BY	CHKD	APPROVED
19/09/14	CHANDRAN	CHANDRAN	CHANDRAN
21/08/14	CHANDRAN	CHANDRAN	CHANDRAN

DATE	BY	CHKD	APPROVED
19/09/14	CHANDRAN	CHANDRAN	CHANDRAN
21/08/14	CHANDRAN	CHANDRAN	CHANDRAN

REV	DATE	BY	CHKD	APPROVED
U 01				

TITLE	DRAWING NO
JAWS	2-M-12B49-05228

1 2 3 4 5 6 7 8 A B C D E F

A2-SIZE

DRAWING NO: 2-M-12B49-05229

ALL DIMENSIONS ARE IN MILLIMETERS

32/16

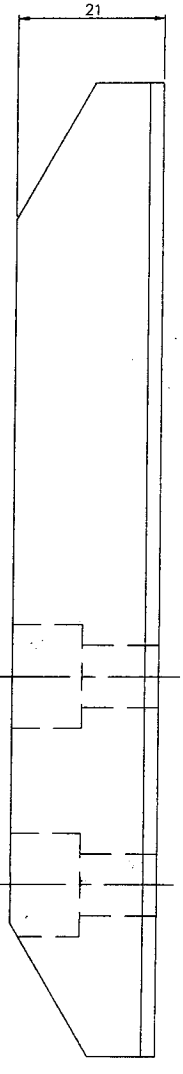
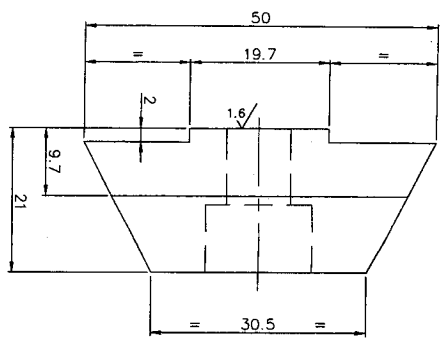
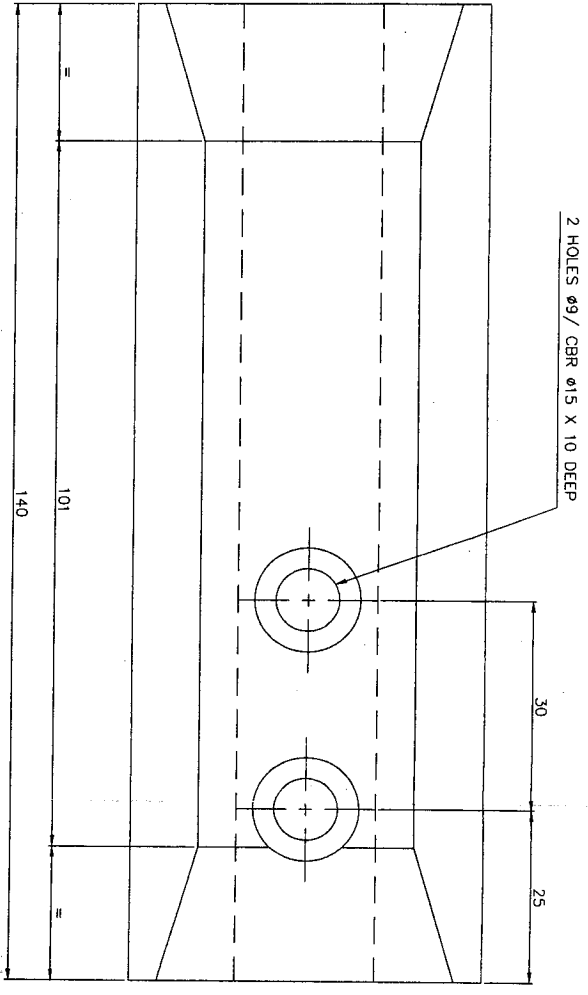

NOTE:

1. DRAWING IS REFERENCE ONLY
2. MANUFACTURING OF THE COMPONENT TO BE DONE ONLY AFTER STUDYING THE ASSEMBLY PHYSICALLY.

REV	DATE	BY	CHKD	DESCRIPTION
01	09/09/14	EN 36 WAS E 290 A		

CAUTION: THE INFORMATION ON THIS DOCUMENT IS THE PROPERTY OF BHARAT HEAVY ELECTRICALS LIMITED. IT MUST NOT BE USED DIRECTLY OR INDIRECTLY IN ANY WAY DETRIMENTAL TO THE INTEREST OF THE COMPANY.

DEPT. NAME	PL 21 X 50 X 140L	ITEM NO	IS 1730	DESCRIPTION	DRAWING NO	EN 36	MATL CODE	1	UNIT WT	0.90
DATE	19/09/14	BY	C. PRINCHANN	CHKD	C. PRINCHANN	DATE	21/09/14	REV		
SCALE	2:1	WEIGHT (KG)	D.90	REF TO ASSY DWG NO		REF TO OLD DWG NO				
TITLE	JAWS GRIPPING PAD									
DRWG CODE	2-M-12B49-05229									

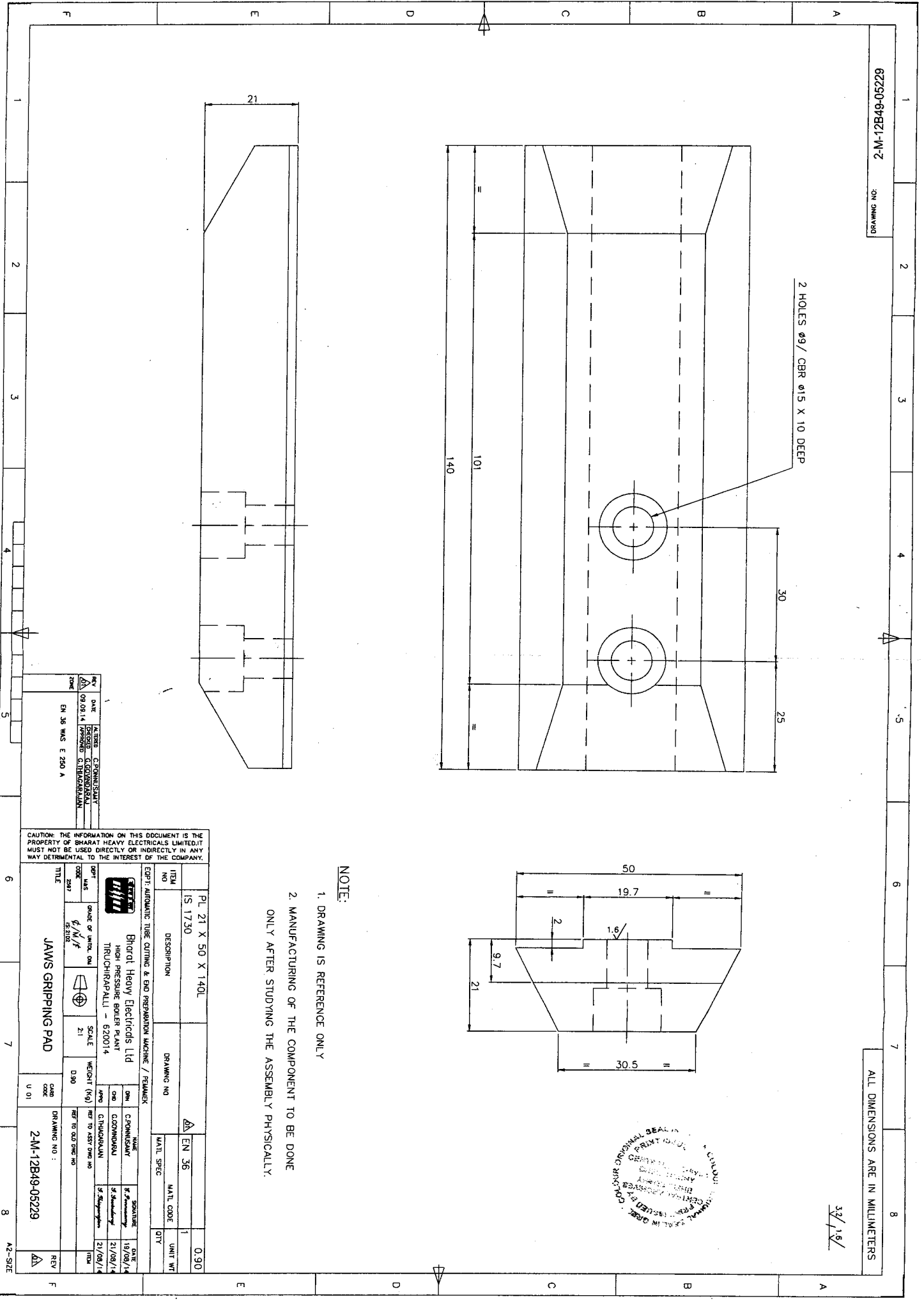

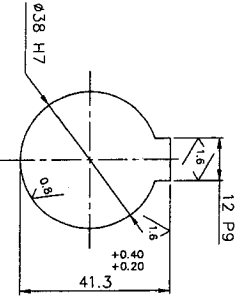
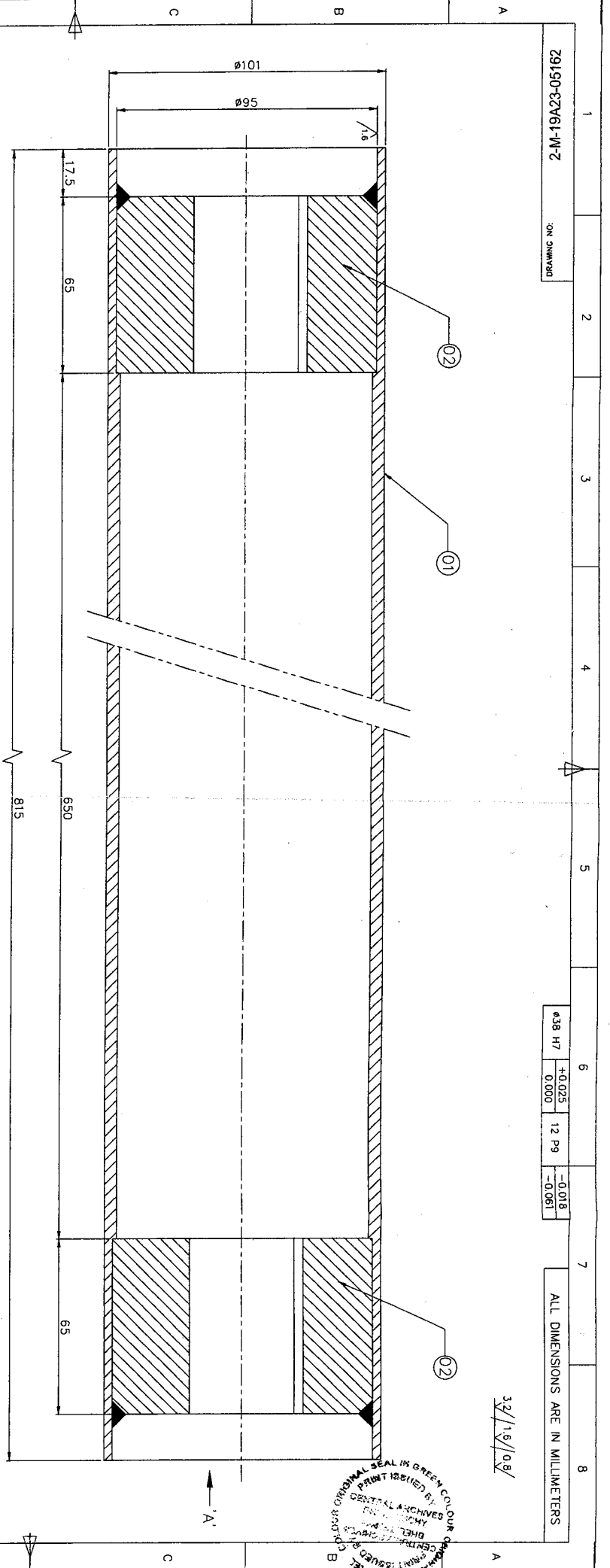

NOTE:-
01. ITEM NO. 01 & 02 ARE WELDED.
02. SHARP CORNERS TO BE REMOVED

0.025	0.018
0.000	-0.061

ALL DIMENSIONS ARE IN MILLIMETERS

32/16/08

REV	DATE	ALTERED
1		
2		
3		
4		
5		

CAUTION: THE INFORMATION ON THIS DOCUMENT IS THE PROPERTY OF BHARAT HEAVY ELECTRICALS LIMITED. IT MUST NOT BE USED DIRECTLY OR INDIRECTLY IN ANY WAY DETRIMENTAL TO THE INTEREST OF THE COMPANY.

02	ROD ϕ 100 x 65L	ASME	3.03
01	PIPE ϕ 108 x 8 x 815L	ASME	8.73

ITEM NO. DESCRIPTION DRAWING NO. MATL. SPEC. QTY.

01 PIPE ϕ 108 x 8 x 815L SA 105 Gr-B 1

02 ROD ϕ 100 x 65L SA 105 2

DEPT. TUBE ROTORFAST MACHINE / 6161 - 4167

BRHAT Heavy Electricals Ltd
HIGH PRESSURE BOILER PLANT
TRICHURAPALLI - 620014

SCALE 1:1

WEIGHT (Kg) 14.79

DRAWING NO: 2-M-19A23-05162

REV: 01



ALL DIMENSIONS ARE IN MM

REV	DATE	ALTERED
		CHECKED
		APPROVED
ZONE		

1.6/

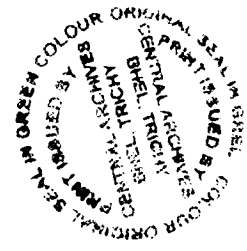
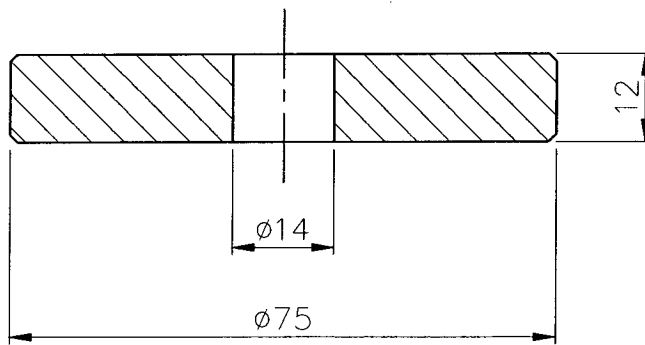

NOTE: -

01. SHARP CORNERS TO BE REMOVED

CAUTION: THE INFORMATION ON THIS DOCUMENT IS THE PROPERTY OF BHARAT HEAVY ELECTRICALS LIMITED. IT MUST NOT BE USED DIRECTLY OR INDIRECTLY IN ANY WAY DETRIMENTAL TO THE INTEREST OF THE COMPANY.

03	PL $\phi 75 \times 12$ IS 1730	—	IS 2062	0.40
ITEM NO	DESCRIPTION	DRAWING NO	MATL CODE	UNIT WT
			MATL SPEC	QTY

EQPT: TUBE ROTOPLAST MACHINE / 6161 - 4167



Bharat Heavy Electricals Ltd
HIGH PRESSURE BOILER PLANT
TIRUCHIRAPALLI - 620014

DRN	NAME N.MADURAVEERAN	SIGNATURE <i>N. Maduraveeran</i>	DATE 19/03/14
CHD	G.GOVINDARAJ	<i>G. Govindaraj</i>	19/03/14
APPD	K.RAMANAN	<i>K. Ramanan</i>	19/03/14

DEPT M&S	GRADE OF UNTOL. DIM $\phi/M/AF$ IS: 2102		SCALE 1:1	WEIGHT (Kg) 0.40	REF TO ASSY DWG NO 2M19A2305147	ITEM 03
CODE 2597					REF TO OLD DWG NO —	
TITLE LOCK PLATE (DIA75 x 12) (BUCKET ELEVATOR)				CARD CODE U 01	DRAWING NO : 4M19A2329787	REV 00

A4-SIZE

CAUTION: THIS DRAWING IS OUR SOLE PROPERTY AND SHOULD NOT BE USED IN ANY FORM FOR ANY PURPOSE WITHOUT THE WRITTEN PERMISSION OF BHARAT HEAVY ELECTRICALS LIMITED TRICHIRAPPALLI - 620 014.

ALL DIMENSIONS ARE IN MM

∅19 h9

-0.000
-0.052

3.2/1.6/

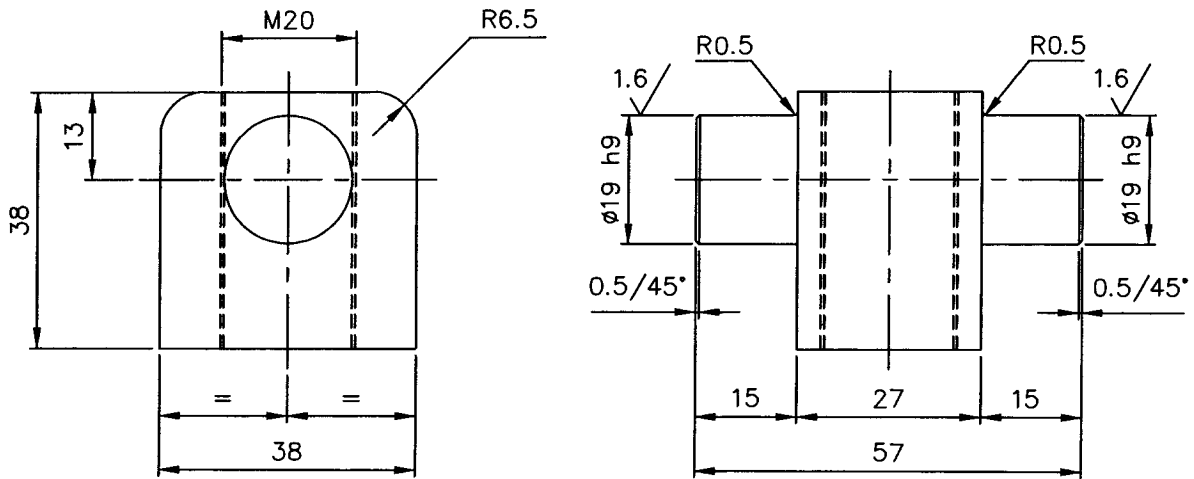
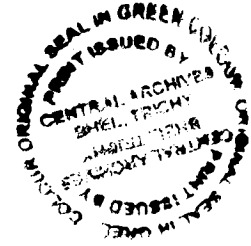

NOTE: -

01. HARDENED TO HRc 58 ^{±2}
02. CASE DEPTH 0.8mm

		13Ni13Cr3 ⁽⁰¹⁾		IS: 4432	0.35	1M12B1801695	08	
						1M12B1700671	16	
X	No. of Pieces	DESCRIPTION	MATERIAL	STANDARD	NET.WT.IN KGS.	DRAWING No.	ITEM No.	
☉		REFERENCE: DRG. No. SC-8000-004 ITEM. No.01		ALTERATIONS:	DCN REF	DATE	SIGN. INDEX	
SCALE	DRAWN/TCD	<i>R. Narayanan</i>	13Ni13Cr3 WAS BM-C30			01.04.13	K.R 01	
1:2	CHECKED	G.GOVINDARAJ						
	APPROVED	K.RAMANAN						
	DATE	29.11.73/01.04.13						
		MACHINE: PORTABLE END CUT SCARFING		TYPE: FBE 38/76				
		TITLE: TRUNNION		DRAWING No:		17		REV.
				4M12B1810698		01		
		No. of Sheets:		Sheet No:				