



# BHARAT HEAVY ELECTRICALS LIMITED

( A Government of India Undertaking )  
HIGH PRESSURE BOILER PLANT  
PURCHASE DEPARTMENT - FOSSIL BOILERS  
THIRUCHIRAPALLI 620014  
TAMILNADU (INDIA)

PHONE :2577629  
GRAMS : BHARATELEC  
FAX NO: 2520719  
E mail: srchandran@bheltry.co.in  
Web:

429-002/A

	<b>Enquiry No</b>	<b>Enquiry Date</b>	<b>Due Date for Quotation</b>
	2661400853 - 55	20.11.2014	17.12.2014
Please quote Enquiry No, Date and due date in all correspondences. This is only a request for quotation and not an order			

Item	Description	Unit	Quantity	Delivery Quantity	Schedule Date
10	7512B1607900 ROLL HOLDER AS PER DRG. NO. 3 M 12B16 15305 COMMON NOTE FOR SL.NO. 10 TO 50: (1) VENDOR SHALL SUBMIT THE MATERIAL TEST CERTIFICATE OBTAINED FROM APPROVED AGENCIES WHILE DELIVERY OF THE MATERIAL. (2) AFTER PLACEMENT OF PURCHASE ORDER ONE NUMBER OF SAMPLE IN EACH ITEM HAS TO BE SUPPLIED FOR BHEL ACCEPTANCE PREFERABLY WITHIN 5 WEEKS. AFTER ACCEPTANCE OF SAMPLE ONLY BALANCE QUANTITY SHALL BE MANUFACTURED AND SUPPLIED.ACCEPTENCE BY BHEL WILL BE GIVEN WITHIN 1 WEEKS. THIS PERIOD (5 + 1 6WEEKS) IS TO BE TAKEN INTO ACCOUNT WHILE QUOTING DELIVERY PERIOD BY THE SUPPLIER. VENDOR QUALIFYING CRITERIA: Only those vendors who satisfy the following conditions will get qualified to participate in the tender: 1. Vendor should have minimum 3 years of experience in this field. 2. Previous PO details for supplying similar kind of items to BHEL and/or any other Organisation should be submitted along with offer. r.Otherwise offer will be rejected. 3. Company profile details has to be provided along with offer. 4. BHEL reserves the right to visit the vendor's works for verifying the manufacturing facilities and any other credential furnished by the vendor. In case the information furnished with the offers found to be false /incorrect, the offer shall be rejected.	NO	40.000	40.00	18.03.15
20	7512B1608000 ROLLER ASSY. AS PER DRG. NO. 3 M 12B16 15284 01, SUB DRG. NO. 4 M 12B16 2980/ 01, 3 M 12B16-15276 01	NO	50.000	50.00	18.03.15
30	7502F1400500	NO	50.000	50.00	18.03.15

The offers should reach us 30 minutes before the time of opening of tenders.  
The offers will be opened at 14.30 hrs on the due date of tender in the presence of tenderers who have submitted their offer and who may like to be present for the tender opening.Late and delayed offers are liable to be rejected.

**VIGILANCE AWARENESS WEEK**

**27 th OCT to 1st NOV 2014**

**FOR VIGILANCE RELATED COMPLAINTS,**

**CONTACT DGM/VIGILANCE**

**PHONE:0431-2577552,2577636**

Yours faithfully,  
For **BHARAT HEAVY ELECTRICALS LIMITED**

MANAGER / PURCHASE  
(FOSSIL BOILERS)  
Yours faithfully,



# BHARAT HEAVY ELECTRICALS LIMITED

( A Government of India Undertaking )  
HIGH PRESSURE BOILER PLANT  
PURCHASE DEPARTMENT - FOSSIL BOILERS  
THIRUCHIRAPALLI 620014  
TAMILNADU (INDIA)

Page  
2/2

PHONE :2577629  
GRAMS : BHARATELEC  
FAX NO: 2520719  
E mail: srchandran@bheltry.co.in  
Web:

2661400853 / 20.11.2014

"V" GROOVE ROLLER AS PER DRG.NO.  
4 M 02F14 18156 -01

40	7510A1305600	NO	2.000	2.00	18.03.15
----	--------------	----	-------	------	----------

WORM SHAFT AS PER DRG. NO.  
2 M 10A13 05251 (SUPERCEDED BY DRG. NO.  
3 M 10A13 08093).

NOTE:

FOR SL.NO. 40 AND 50 ARE MATING  
COMPONENTS. HENCE THESE ITEMS SHOULD  
BF  
PROCEURED FROM SINGLE SOURCE ONLY.

50	7510A1305700	NO	2.000	2.00	18.03.15
----	--------------	----	-------	------	----------

WORM WHEEL AS PER DRG. NO.  
2 M 10A13-05252 (SUPERCEDED BY DRG. NO.  
3 M  
10A13 08092).

### General Note:

GENERAL NOTE:PLEASE SUBMIT YOUR OFFER IN "TWO PART BID SYSTEM" AS PER  
THE ANNEXURES ENCLOSED.

ENCLOSURES:ANNEXURE II,III,IV,V,VI,VII.

### Enclosures:

"LD clause has to be confirmed without fail."

The offers should reach us 30 minutes before the time of opening of tenders.  
The offers will be opened at 14.30 hrs on the due date of tender in the presence of  
tenderers who have submitted their offer and who may like to be present for the tender  
opening.Late and delayed offers are liable to be rejected.

**VIGILANCE AWARENESS WEEK**

**27 th OCT to 1st NOV 2014**

**FOR VIGILANCE RELATED COMPLAINTS,**

**CONTACT DGM/VIGILANCE**

**PHONE:0431-2577552,2577636**

Yours faithfully,  
For BHARAT HEAVY ELECTRICALS LIMITED

MANAGER / PURCHASE  
(FOSSIL BOILERS)

Yours faithfully,

**CAPITAL PURCHASE**  
**COMMERCIAL TERMS AND CONDITIONS**

**1.0 QUOTATIONS**

The Bidders shall submit the offer in **TWO INNER ENVELOPES** as indicated below which shall be sealed in one outer envelope.

**Envelope I** This sealed envelope should contain all the copies of technical bid together with un-priced commercial bid & annexure III. This envelope should be clearly marked **'Part I - Technical and commercial bid'**,

Indicating Enquiry No., Due Date and Address & Reference of the Bidder.

**Envelope II** This sealed envelope should contain **price as per Annexure-IV format**. This envelope should be clearly marked **"Part II - Price bid"**, indicating **Enquiry No., Due Date and Address & Reference of the Bidder**.

Both the envelopes (Part I & II) shall be put in one cover (**Envelope III**), duly sealed, superscribing as Part I and Part II of Enquiry No., due date of opening and the address and reference of the Bidder

The above offer should reach this office on or before the due date by 14.00 hours (IST). Late offers will not be considered.

Tender should not be addressed to any individual's name but only by designation to

**SENIOR MANAGER /PURCHASE/ CP & SP/ MM / MFG  
BHARAT HEAVY ELECTRICALS LIMITED  
HIGH PRESSURE BOILER PLANT  
TIRUCHIRAPALLI - 620 014  
TAMIL NADU**

Tenders should be free from **CORRECTION AND ERASURES**, Corrections if any, must be attested. All Amounts shall be indicated both in words as well as in figures. Where there is difference between amount quoted in words and figures, amount quoted in words shall prevail.

Offers should be in **ENGLISH** and accompanied by detailed technical literature, catalogue and detailed dimensional drawings in **ENGLISH** or otherwise, the offers will not be considered.

**2.0 OPENING OF TENDERS**

The Part I - Technical & commercial bid alone would be opened on the Tender opening date.

The Part II - Price bid of technically suitable Bidders alone would be opened. The Technically Suitable Bidders would be informed about the tender opening date through e-mail.

Clarifications if any required by BHEL for Technical evaluation **would be** sought from Bidders before opening of Part II - price bid

**For any queries clarifications the bidders may contact us through our FAX NO. +91 431 2520719 or through e-mail <mmcpmfg1@bheltry.co.in >&< chells@bheltry.co.in>**

MM: CP &amp; SP

**Annexure For Techno Commercial Bid**

Check List - to be filled and submitted along with Technical Bid

BHEL Commercial Terms and Conditions for Indigenous Supplies	Vendor's Confirmation / Comments
Technical confirmation to BHEL's Specification as called for in BHEL Format shall be furnished. If needed additional sheets shall be used.	
Prices shall be <b>quoted item wise</b> only as per the model format enclosed	
Prices shall be quoted on " <b>FIRM PRICE</b> " basis only The prices should be only on F.O.R /	
<b>Despatching station</b> basis with <b>Packing &amp; Forwarding</b> charges if any. <b>Applicable % of ED &amp; Sales Tax, Freight &amp; Insurance, Installation &amp; Commissioning Charges should be clearly Indicated</b>	
<b>Validity of offer</b> shall be for a minimum period of 120 days from the date of Tender opening	
Delivery period from the date of Letter of Intent / Purchase order shall be clearly mentioned in the offer	
<b>Liquidated damages @ 0.5% per week</b> subject to a maximum of 10% of the order value shall be applicable for delay in deliveries <b>For Details Refer Annexure- v</b>	
<b>Following Risk Purchase clause</b> shall be applicable	
The purchaser at his option will be entitled to terminate the contract and to purchase elsewhere at the risk and cost of the seller either the whole of the goods or any part which the supplier has failed to deliver or dispatch within the time stipulated or if the same were not available, the best and the nearest available substitute therefore The supplier shall be liable for any loss which the Purchaser may sustain by reason of such purchases	
<b>Payment term for supply portion:</b>	
Payment term is 100% direct payment after 45 days from the date of receipt and acceptance of materials	
<b>For details Refer Annexure- v</b>	
Erection / commissioning: (if applicable only)	
Erection / commissioning charges if any has been mentioned in the offer or else confirmation that Erection /commissioning shall be done at free of cost is available in the offer,	
The equipment shall be guaranteed for a period of 12 months from the date of commissioning	
Final inspection and acceptance of equipment will be after installation at BHEL, Trichy	
The vendor shall provide necessary drawings, Test Certificates and Operating Maintenance Manuals etc., as called for in the Technical Specification, in the required number of copies at no extra cost	
Any warranty replacement during warranty period shall be supplied free of charge on FOR BHEL, Trichy basis.	
Offers should be submitted only in <b>sealed cover super-scribing clearly the Enquiry reference and due date.</b>	
% of Excise Duty with cess	
% of TAX (CST/VAT) (INGST with FORM-17 or CST with C-FORM)	
Packing & Forwarding Charges ( if any in % only)	
Percentage of Freight& transit insurance charges, if any	
Freight charges from Dispatching station to BHEL,	
Tiruchirappalli	
<ul style="list-style-type: none"> <li>Supplier should quote for F.O.R-BHEL Trichy Stores.</li> </ul>	
As per Commercial terms and conditions, acceptance for participation in	
Reverse auction (RA). Yes/No to be indicated	
Name of the person for participating reverse auction	
Land Line Number	
Fax Number	
Mobile Number	
E-mail ID	

## NOTE:-

- It is confirmed that all the terms and conditions stipulated In the Enquiry have been fully understood by us and all clarifications & details have been obtained.
- Your offer should be indicating applicable If any P&F Charges, % of ED, Sales Tax -CST or VAT, Service Tax), Freight, Insurance and Installation and Commissioning Charges etc., as per our Price Format
- Your specific acceptance to our Payment terms, LD & Risk Purchase Clause are essential for consideration of your offer. Other wise your offer is liable for rejection.
- No row shall be left blank. Please indicate NA, in case the item is "not applicable"



**Payment Term (Indigenous)**

**If materials are receivable at Stores/Trichy without PBG**

Payment term is 100% direct payment after 45 days from the date of receipt and acceptance of materials.

**If materials are receivable at Stores/Trichy with PBG**

Payment term is 100% direct payment after 45 days from the date of receipt and acceptance of materials and against 10% PBG valid for the warranty period.

Any deviation in the above payment term will attract loading as mentioned below.

~Base rate of SBI (as applicable on the date of bid opening. Techno-commercial bid opening in case of two part bids) + 6% shall be considered for loading for the period of relaxation sought by bidders.

Payment through Bank is not preferred. In case of Payment through Bank is opted by Supplier, BHEL prefers documents submission through bank with copy of LR and door delivery of Goods to Site/Stores with Consignee copy attached. In this case Loading will be 3% on the offered value.

Offers of indigenous Suppliers with payment terms as I.C/Advance Payment are liable for rejection.

**Liquidated Damages / Penalty -**

Liquidated damages shall be 0.5% of the total order value per week or part thereof subject to a maximum of 10% of the total order value.

For staggered delivery schedule, LD shall be 0.5% of the undelivered portion per week of the delay or part thereof subject to a maximum of 10% of the total order value.

Any deviation from the above LD clause, loading will be applied to the extent to which it is not agreed by the bidder (at offered value).

**Guarantee / Warranty Period – (if applicable)**

Normally No deviation permitted and the deviated offers are liable for rejection.

**Ranking-**

BHEL will consider the ranking after the loading is applied as referred above wherever deviations are observed.

**Performance Bank Guarantee – (if applicable)**

Normally No deviation permitted and the deviated offers are liable for rejection.

**NOTE:-**

1. If the due date of tender opening happens to be a holiday, the tenders will be opened on the next working day.
2. BHEL reserves the right to go for a reverse auction (RA) instead of opening the submitted sealed bid which will be decided after technical evaluation. Information and general terms and conditions covering RA are given in commercial terms and conditions.
3. Corrigendum if any, with respect to this tender will be hosted only in the website <http://www.bhel.com> or <http://tenders.gov.in>. You are requested to visit the website regularly for updates.

**Special Provisions for Micro and Small Enterprises (MSE)**

1. 20% of the tendered quantity is earmarked for MSE suppliers in this tender.
2. Out of the 20% tendered quantity reserved for MSE suppliers, 4% shall be earmarked for procurement from MSE owned by SC/ST entrepreneurs.
3. In case MSE vendor participating in the tender quotes within the price band of L1+15%, they will be allowed to supply the portion of the requirement subject to acceptance of L1 price by MSE vendor. In case of more than one such MSE, the supply shall be shared proportionately.
4. "MSE suppliers can avail the intended benefits only if they submit along with the offer, attested copies of either EM II certificate having deemed validity (five years from the date of issue of acknowledgement in EM-II) or valid NSIC certificate or EM II certificate along with attested copy of a CA certificate (Format enclosed at Annexure -VII where deemed validity of EM II certificate of five Years has expired) applicable for the relevant financial year (latest audited). Date to be reckoned for determining the deemed validity will be the date of bid opening (Part 1 in case of two part bid). Non submission of such documents will lead to consideration of their bid at par with other bidders. No benefit shall be applicable for this enquiry if any deficiency in the above required documents are not submitted before price bid opening. If the tender is to be submitted through e-procurement portal, then the above required documents are to be uploaded on the portal. Documents should be notarized or attested by a Gazetted officer."

**Certificate by Chartered Accountant on letter head**

This is to Certify that M/S .....  
(hereinafter referred to as 'company') having its registered office at  
..... is registered under MSMED Act 2006, (Entrepreneur  
Memorandum No (Part-II) ..... dtd:.....,  
Category: ..... (Micro/Small). (Copy enclosed).

Further verified from the Books of Accounts that the investment of the company as on  
date..... as per MSMED Act 2006 is as follows:

1. **For Manufacturing Enterprises:** Investment in plant and machinery (i.e. original cost excluding land and building and the items specified by the Ministry of Small Scale Industries vide its notification No.S.O.1722(E) dated October 5, 2006 :  
Rs.....Lacs
2. **For Service Enterprises:** Investment in equipment (original cost excluding land and building and furniture, fittings and other items not directly related to the service rendered or as may be notified under the MSMED Act, 2006:  
Rs.....Lacs

The above investment of Rs.....Lacs is within permissible limit of  
Rs.....Lacs for .....Micro / Small (~~Strike off which is not applicable~~)  
Category under MSMED Act 2006.

Date:

(Signature)

Name -

Membership number -

Seal of Chartered Accountant

ALL DIMENSIONS ARE IN MILLIMETRES

$\phi 81.84$ h11	-0.000	$\phi 47$ H7	+0.025
	-0.220		0.000

3.2/16/0.8/

3-M-12B16-15305

DRAWING NO.

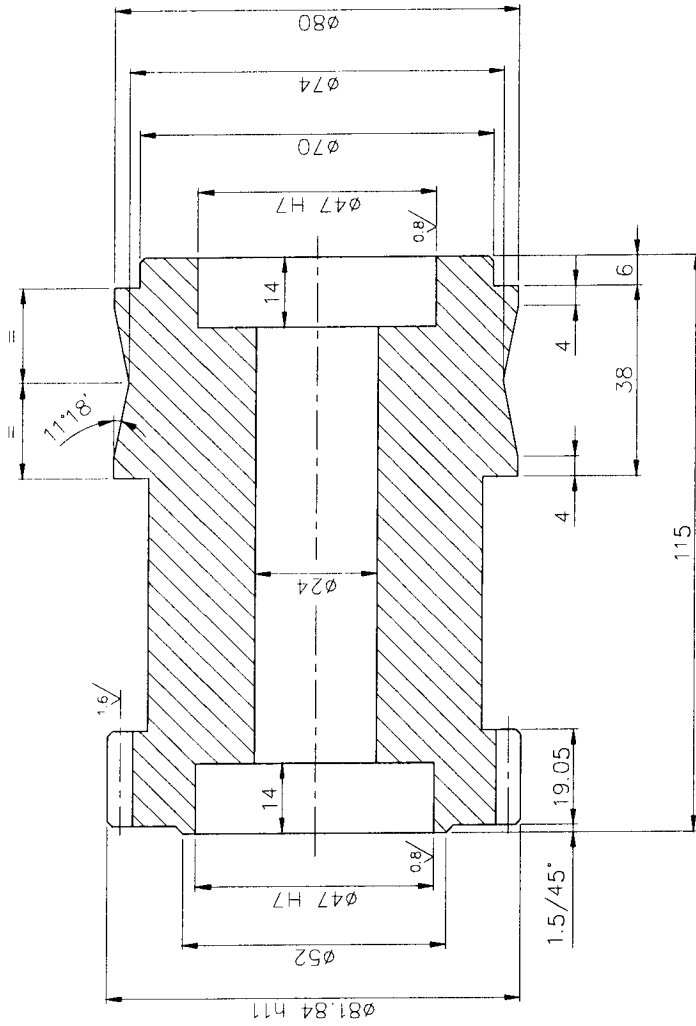

NO. OF TEETH	25
MODULE	3
PRESSURE ANGLE	20°
WIDTH ACROSS 4 TEETH	32.467
CORRECTION FACTOR	+0.14
OLTY.&TOL.ZONE	9c DIN 3967
MATING GEAR NO.OF TEETH	34
MATING GEAR DRAWING NO.	4M12B1622809
CENTRE DISTANCE	88.9

ITEM NO	IS 1762	DESCRIPTION	ROD $\phi 82 \times 115L$	IS 2004	4.13
DEPT	M&S	GRADE OF UNTO. DIM	$\phi / M / F$ S.2102	45 CB	1
CODE	2597	SCALE	1:1	MATL CODE	MATL SPEC
DEPT	M&S	WEIGHT (Kg)	4.13	DRAWING NO	QTY
CODE	2597	REF TO ASSY DWG NO			
		REF TO OLD DWG NO	3M12B1610836 & 3M12B1609731		
TITLE			DRAWING NO :		
ROLL HOLDER $\phi 81.84 \times 25T$ (FEED ASSY.)			3-M-12B16-15305		
CAUTION: THE INFORMATION ON THIS DOCUMENT IS THE PROPERTY OF BHARAT HEAVY ELECTRICALS LIMITED. IT MUST NOT BE USED DIRECTLY OR INDIRECTLY IN ANY WAY DETRIMENTAL TO THE INTEREST OF THE COMPANY.			REV		
REV	DATE	ALTERED	DATE	REV	00
		CHECKED	21/07/14		
		APPROVED			
EQUIP: MODEL CUT OFF MACHINE/MODEL/3K			SIGNATURE		
Bharat Heavy Electricals Ltd			M. Madhavan		
HIGH PRESSURE BOILER PLANT			G. Govindaraj		
TIRUCHIRAPALLI - 620014			G. Thirarajan		
DRN			DATE		
CHD			21/07/14		
APPD			21/07/14		

A3-SIZE



ALL DIMENSIONS ARE IN MM

REV	DATE	ALTERED	N.MADURAI VEERAN	φ72 H7	+0.030
▲	14.06.14	CHECKED	G.GOVINDARAJ		0.000
		APPROVED	S.P.INKERSAL		

3.2/1.6/0.8/

ZONE ITEM NO. - 02 ADDED

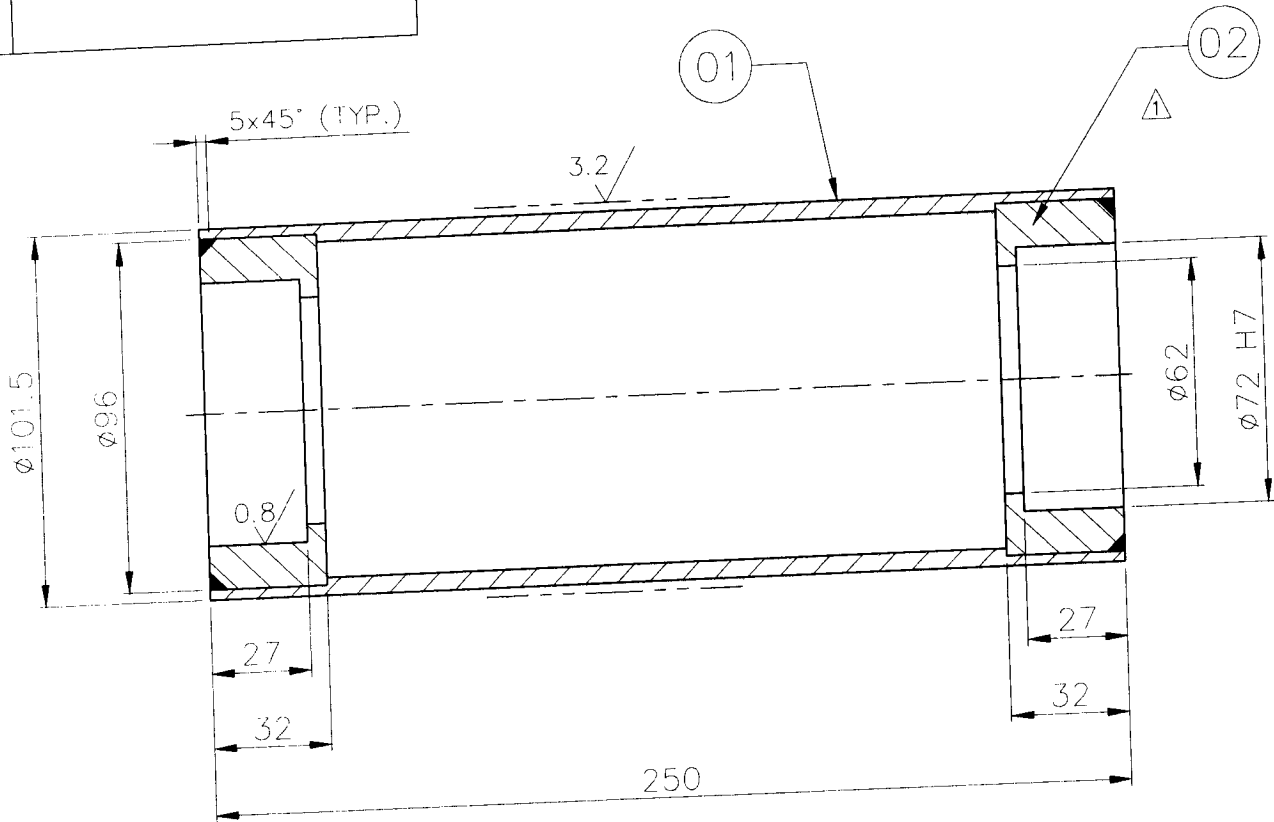

NOTE: -

- 01. ----- CASE HARDENED. CASE DEPTH 0.8MM.
- 02. SHARP CORNERS TO BE REMOVED.
- 03. ITEM NO. 01 & 02 ARE WELDED.

02	ROD φ100 x 32L		ASME	1.06
			SA 105	2
01	PIPE φ108x8tx250L		ASME	2.83
			SA 106 Gr B	1
ITEM NO	DESCRIPTION	DRAWING NO	MATL CODE	UNIT WT
			MATL SPEC	QTY

EQPT: MODEL CUT OFF MACHINE/MODEL/3K/NEW MCO



**Bharat Heavy Electricals Ltd**  
HIGH PRESSURE BOILER PLANT  
TIRUCHIRAPALLI - 620014

DRN	NAME	SIGNATURE	DATE
CHD	S.SELVAMANICKAM	<i>S.Selvamanickam</i>	31.05.14
APPD	G.GOVINDARAJ	<i>G.Govindaraj</i>	04.06.14
	S.P.INKERSAL	<i>S.P.Inkersal</i>	04.06.14

DEPT	GRADE OF UNTOL. DIM		SCALE	WEIGHT (Kg)
M&S	φ/M/AF		1:2	4.95
CODE	IS: 2102			

REF TO ASSY DWG NO	ITEM
3-M-12B16-15284	01
REF TO OLD DWG NO	
-	

TITLE	CARD CODE	DRAWING NO :	REV
<b>ROLLER (Ø101.5x250L)</b>	U 01	<b>4M12B1629807</b>	▲

CAUTION: THE INFORMATION ON THIS DOCUMENT IS THE PROPERTY OF BHARAT HEAVY ELECTRICALS LIMITED. IT MUST NOT BE USED DIRECTLY OR INDIRECTLY IN ANY WAY DETRIMENTAL TO THE INTEREST OF THE COMPANY.

A4-SIZE

ALL DIMENSIONS ARE IN MILLIMETRES

DRAWING NO. 3M12B1615276

±0.018  
+0.002

3.2/1.6/0.8/1.6

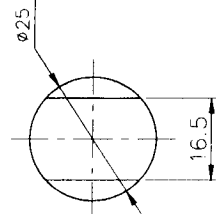
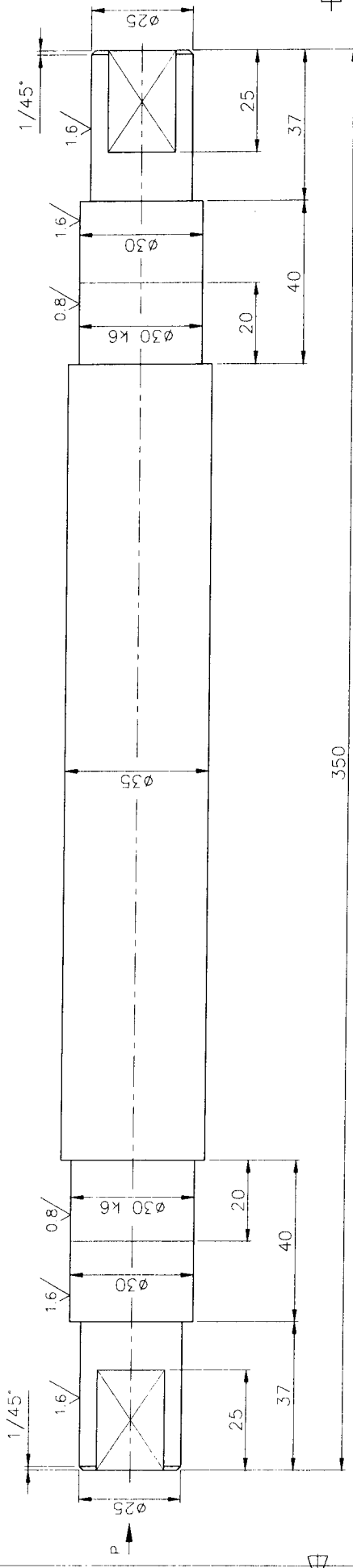

VIEW-P

NOTE: SHARP CORNERS TO BE REMOVED

02	ROD Ø36 x 350L	3-M-12B16-15284	SA 105	ASME	2.28
ITEM NO	DESCRIPTION	DRAWING NO	MATL CODE	MATL SPEC	UNIT WT
EQUIP: MODEL CUT OFF MACHINE/MODEL/3K/NEW/MCO					
Bharat Heavy Electricals Ltd HIGH PRESSURE BOILER PLANT TIRUCHIRAPALLI - 620014		NAME	SIGNATURE	DATE	
DEPT	GRADE OF UNTOOL DIM	DRN	S.SELVAMANICKAM	J. Selvamani	30.05.14
M&S	Q/M/F	CHD	G.GOVINDARAJ	S. Sundaraj	04.06.14
CODE	S.2102	APPD	S.P.INKERSAL	J.P. Subramani	04.06.14
SCALE		WEIGHT (Kg)	REF TO ASSY DWS NO	ITEM	
1:1		2.28	3-M-12B16-15284	02	
TITLE		REF TO OLD DWS NO			
ROLLER SHAFT Ø35x350 L (ROLLER ASSY.)		DRAWING NO : 3M12B1615276			
CARD CODE		REV			
U 01		A			

CAUTION: THE INFORMATION ON THIS DOCUMENT IS THE PROPERTY OF BHARAT HEAVY ELECTRICALS LIMITED. IT MUST NOT BE USED DIRECTLY OR INDIRECTLY IN ANY WAY DETRIMENTAL TO THE INTEREST OF THE COMPANY.

REV	ALTERED	N.MADURAIKERAN
Δ	CHECKED	G.GOVINDARAJ
	APPROVED	S.P.INKERSAL
DATE	14.06.14	
ZONE	MATL-CHANGED SA 105 WAS 45 CB	

A3-SIZE

THIS DRAWING IS OUR SOLE PROPERTY AND SHOULD NOT BE USED IN ANY FORM FOR ANY PURPOSE WITHOUT THE WRITTEN PERMISSION OF BHARAT HEAVY ELECTRICALS LIMITED TRICHIRAPPALLI - 620 014.

CAUTION:

ALL DIMENSIONS ARE IN MM

ø47H7	+0.025
	+0.000

3.2/1.6/0.8/
✓/✓/✓

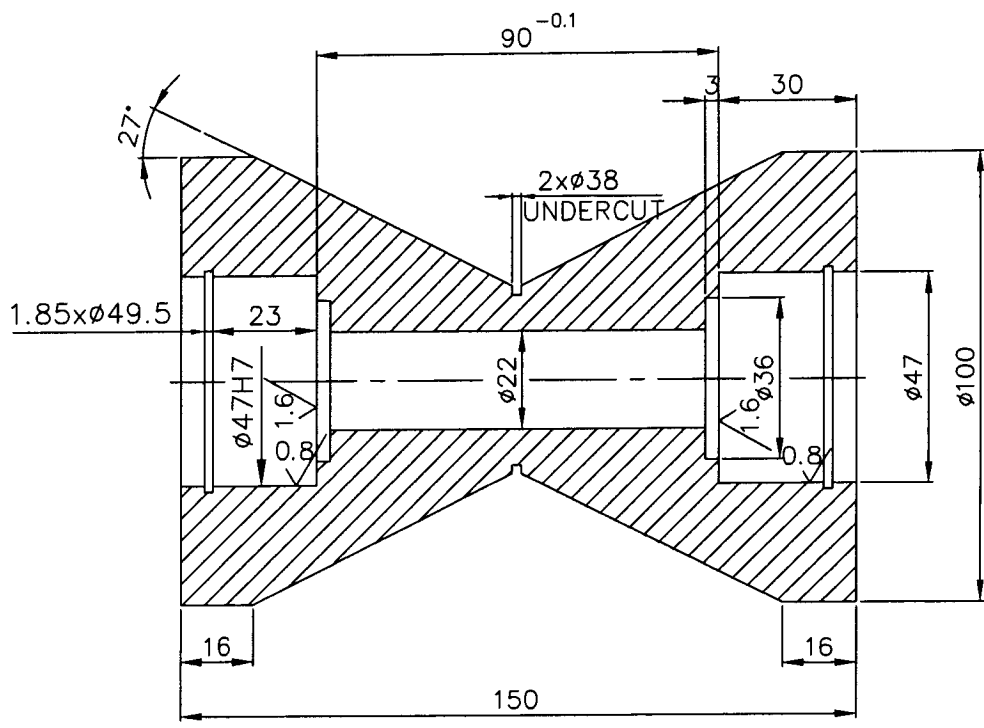

CORNERS TO BE CHAMFERED 1/45°

No. of Pieces	ASSY	Gr.280-520N	IS:1030	1.2	4M20A1424895 4M02F1415229	01		
	DESCRIPTION	MATERIAL	STANDARD	NET.WT.IN KGS.	DRAWING No.	ITEM No.		
SCALE	REFERENCE:		ALTERATIONS:		DCN REF	DATE	SIGN.	INDEX
	1:2	V.KRISHNAPRIYA		DRG. MODIFIED TO DATE		15.03.12	CSJ	01
	CHECKED	R.RAMAMOORTHY						
	APPROVED	C.S.JAYASHEELAN						
	DATE	27.09.78/07.07.708						
MACHINE: FACILITY				TYPE: STWD				
TITLE: 'V' GROOVE ROLLER				DRAWING No:				
ø100x150L				4M02F141815601				
Sheet No:				No. of Sheets:				

2-M-10A13-05251

ON CHINA

3

4

5

6

7

8

ALL DIMENSIONS ARE IN MILLIMETERS

3.2/1.6/0.8/

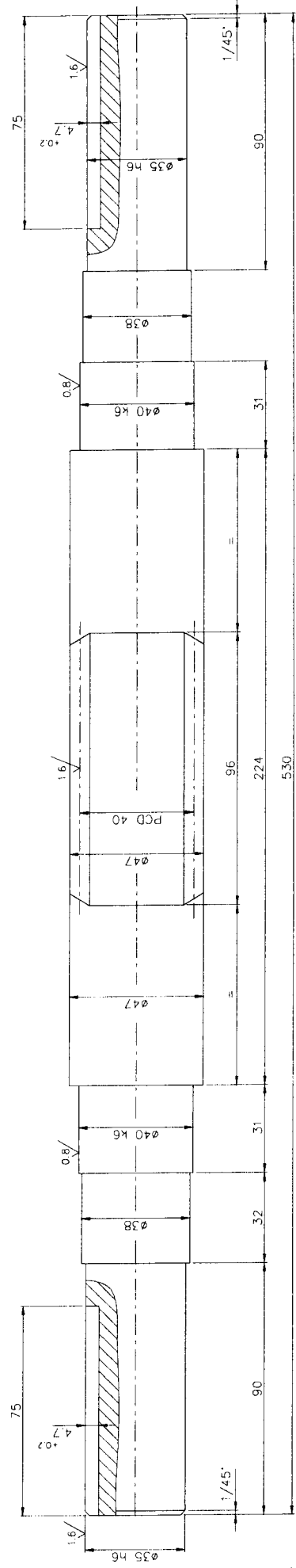
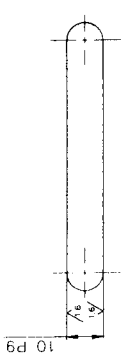
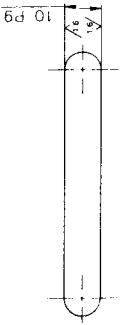

SUPERCEDED BY DRG.NO. - 3M10A1308093

NOTE:-

01: SHARP CORNERS TO BE REMOVED

NO. OF STARTS	SINGLE
MODULE	3.5
PRESSURE ANGLE	20°
HELIX ANGLE	5°
HAND OF HELIX	R.H
AXIAL PITCH	10.995
MATING GEAR NO. OF TEETH	60
MATING GEAR DRG. NO.	2-M-10A13-05252
CENTRE DISTANCE	125

ITEM NO	ROD Ø50 x 530L	IS 2004	5 23
DESCRIPTION	ROD Ø50 x 530L	45 C8	1
LOFT	PANEL PROCESSING MACHINE / FLUID / 0083.1989		
DATE	12/11/14	SIGNATURE	N. MADHURAJAN
CHKD	G. GOVINDARAJ	DATE	12/11/14
DRG NO	2-M-10A13-05251	CHKD	G. THIRUGANAN
SCALE	1:1	REF TO ASSIST DRG NO	11/04/00
WEIGHT (Kg)	5.23	REF TO DRG DRG NO	
SCALE	1:1	DRG NO	2-M-10A13-05251
SCALE	1:1	REV	00
SCALE	1:1	REV	00

REV	00
DATE	12/11/14
SIGNATURE	N. MADHURAJAN
DATE	12/11/14
SIGNATURE	G. GOVINDARAJ
DATE	12/11/14
SIGNATURE	G. THIRUGANAN
DATE	12/11/14
SIGNATURE	
DATE	
SIGNATURE	
DATE	

WORM SHAFT (1 START / Ø47)  
(3rd & 4th PRESSURE ROLLER GEARBOX)

