



BHARAT HEAVY ELECTRICALS LIMITED

(A Government of India Undertaking)
HIGH PRESSURE BOILER PLANT
PURCHASE DEPARTMENT - FOSSIL BOILERS
THIRUCHIRAPALLI - 620014
TAMILNADU (INDIA)

PHONE :2577331
GRAMS : BHARATELEC
FAX NO: 2520719
E-mail: srchandran@bheltry.co.in
Web:

429-002/A

	Enquiry No 2661500488 - 55	Enquiry Date 18.11.2015	Due Date for Quotation 21.12.2015
<p>Please quote Enquiry No, Date and due date in all correspondences. This is only a request for quotation and not an order.</p> <p>Bid should be submitted in two parts. 1.Techno-commercial bid (Part-I) and 2.Price bid(Part-II) in a separate sealed cover and both covers must be placed in a third cover and sealed. Our Enquiry No., Enq. date & Enq. Due date must be written on all three covers.</p>			

Item	Description	Unit	Quantity	Delivery Quantity	Schedule Date
10	<p>V ROLLER ASSEMBLY AS PER BHEL REFERENCE DRAWING :3-M-12B25-15368 INCLUSIVE OF THE FOLLOWING SUB ASSEMBLY DRAWINGS TAPER ROLLER :3-M-12B25-14963-01 TAPER ROLLER PIN :4-M-12B25-29497-01 BRG. END COVER-1 :4-M-12B25-29498 BRG. END COVER-2 :4-M-12B25-29499 V ROLLER SLEEVE :4-M-12B25-29833 GENERAL CONDITIONS FOR ITEM 10, 20 AND 30:</p> <p>-----</p> <p>1. THE DRAWING IS ONLY FOR REFERENCE PURPOSE.HENCE THE VENDOR SHOULD MAKE A VISIT TO UNIT II/BHEL/TRICHY FOR #ON THE SPOT# STUDY OF BHEL'S REQUIREMENT, PRIOR TO SUBMITTING THE TECHNICAL OFFER. THE OFFER SUBMITTED WITHOUT VISIT AND ASSESSMENT OF THE EXISTING ITEM SHALL NOT BE CONSIDERED FOR EVALUATION.</p> <p>2. FOR ITEM 10: VENDOR SHOULD ENSURE BOTH FERROUS AND HARD RUBBER SHOULD HAVE PERFECT LOCK AND BONDING AND SHOULD NOT PEEL OFF WHILE ON OPERATION.</p> <p>3. AS THE DRAWING IS ONLY FOR REFERENCE PURPOSE, AFTER PLACEMENT OF PURCHASE ORDER 5 NUMBERS OF EACH SAMPLE (ITEM 10, 20 AND 30) SHOULD BE SUPPLIED WITH MATERIAL CONFORMANCE TEST CERTIFICATE PREFERABLY WITHIN 5 WEEKS FOR BHEL ACCEPTANCE.AFTER GETTING SAMPLE ACCEPTANCE FROM BHEL, BALANCE PO QUANTITY SHALL BE SUPPLIED.ACCEPTANCE FROM BHEL WILL BE GIVEN WITHIN 2 WEEKS.THIS PERIOD (5+2 = 7 WEEKS) SHALL BE TAKEN IN TO ACCOUNT WHILE QUOTING DELIVERY PERIOD BY THE SUPPLIER.</p> <p>VENDOR QUALIFYING CRITERIA:</p> <p>-----</p> <p>ONLY THOSE VENDORS WHO SATISFY THE FOLLOWING CONDITIONS WILL GET</p>	NO	57.000	57.00	02.01.16

The offers should reach us 30 minutes before the time of opening of tenders. The offers will be opened at 14.30 hrs on the due date of tender in the presence of tenderers who have submitted their offer and who may like to be present for the tender opening.Late and delayed offers are liable to be rejected.

VIGILANCE AWARENESS WEEK
26 th OCT to 31st OCT 2015
FOR VIGILANCE RELATED COMPLAINTS,
CONTACT DGM/VIGILANCE & SM/VIGILANCE
PHONE:0431-2577552,2577636

Yours faithfully,
For BHARAT HEAVY ELECTRICALS LIMITED

V. CHELLIAH
MANAGER (PURCHASE
Sr Manager (Purchase)
MM / RM / CP & SP
BHEL, TRICHY - 620 014.



BHARAT HEAVY ELECTRICALS LIMITED

(A Government of India Undertaking)
HIGH PRESSURE BOILER PLANT
PURCHASE DEPARTMENT - FOSSIL BOILERS
THIRUCHIRAPALLI - 620014
TAMILNADU (INDIA)

Page
2/3
PHONE :2577331
GRAMS : BHARATELEC
FAX NO: 2520719
E-mail: srchandran@bheltry.co.in
Web:

2661500488 / 18.11.2015

23505

QUALIFIED TO PARTICIPATE IN THE TENDER:
1. VENDOR SHOULD HAVE MINIMUM 2 YEARS OF EXPERIENCE IN THIS FIELD.
2. PREVIOUS PO DETAILS FOR SUPPLYING SIMILAR KIND OF ITEMS TO BHEL AND / OR ANY-OTHER ORGANISATION SHOULD BE SUBMITTED ALONG WITH OFFER. OTHERWISE OFFER WILL BE REJECTED.
3. COMPANY PROFILE DETAILS HAS TO BE PROVIDED ALONG WITH OFFER.
4. BHEL RESERVES THE RIGHT TO VISIT THE VENDOR'S WORKS*FOR VERIFYING THE MANUFACTURING FACILITIES AND ANY OTHER CREDENTIAL FURNISHED BY THE VENDOR. IN CASE THE INFORMATION FURNISHED WITH THE OFFERS FOUND TO BE FALSE / INCORRECT, THE OFFER SHALL BE REJECTED.

20	ROLLER SLEEVE AS PER BHEL REFERENCE DRAWING: 4-M-12B49-29863	NO	35.000	35.00	02.01.16
30	ROLLER SLEEVE AS PER BHEL REFERENCE DRAWING: 4-M-12B49-29864	NO	25.000	25.00	02.01.16

General Note:

GENERAL NOTE:PLEASE SUBMIT YOUR OFFER IN "TWO PART BID SYSTEM" AS PER THE ANNEXURES ENCLOSED.

ENCLOSURES:ANNEXURE II,III,IV,V,VI,VII

All the tenders may be addressed to the following address:

**The Tender Opening Cell / MM
Room No: 26, Building 24, Ground Floor
Bharat Heavy Electricals Limited
TIRUCHIRAPALLI 620014**

In case personal delivery of the offer, it shall be dropped into the respective box kept in Room No: 26, after duly entering the data in the system.

Offers will be accepted only up to 14.00 Hrs on the due date. Therefore, vendors shall ensure to submit the offers well before this time. All due date extension requirements should be addressed to the respective Purchase mail IDs. All the due date extension requests from vendors will be considered only up to 48 hours before the due date and time.

Vendors are requested to avoid submission of offers through e mail / fax. In case of any unavoidable situation, offers shall be sent through e mail to the following mail ID only tender_cell@bheltry.co.in.

As tenders are being opened by Common Tender Opening Cell, offer covers should be sealed with tenderer's distinctive seal and super scribed with correct Tender No. item of supply and due date of opening.

The offers should reach us 30 minutes before the time of opening of tenders.
The offers will be opened at 14.30 hrs on the due date of tender in the presence of tenderers who have submitted their offer and who may like to be present for the tender opening.Late and delayed offers are liable to be rejected.

VIGILANCE AWARENESS WEEK

26 th OCT to 31st OCT 2015

FOR VIGILANCE RELATED COMPLAINTS,

CONTACT DGM/VIGILANCE & SM/VIGILANCE

PHONE:0431-2577552,2577636

Yours faithfully,
For BHARAT HEAVY ELECTRICALS LIMITED

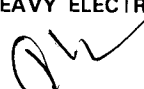
V. MANAGER / PURCHASE
Sr Manager (SSR BOILERS)
MM / RM YCP & SR
BHEL, TRICHY - 620 014



BHARAT HEAVY ELECTRICALS LIMITED

(A Government of India Undertaking)
HIGH PRESSURE BOILER PLANT
PURCHASE DEPARTMENT - FOSSIL BOILERS
THIRUCHIRAPALLI - 620014
TAMILNADU (INDIA)

Page 3/3
PHONE :2577331
GRAMS : BHARATELEC
FAX NO: 2520719
E-mail: srchandran@bheltry.co.in
Web:

2661500488 / 18.11.2015

23505

The offers will be opened at 14.30 hrs on the due date of the tender in the presence of tenderers who have submitted their offer and who may like to be present for the tender opening. Late and delayed offers are liable to be rejected.

The bidder along with its associate/ collaborators/ sub-contractors/ sub-vendors/ consultants/ service providers shall strictly adhere to BHEL fraud prevention policy displayed on BHEL website <http://www.bhel.com> and shall immediately bring to the notice of BHEL management about any fraud or suspected fraud as soon as it comes to their notice.

Enclosures:

"LD clause has to be confirmed without fail."

The offers should reach us 30 minutes before the time of opening of tenders.
The offers will be opened at 14.30 hrs on the due date of tender in the presence of tenderers who have submitted their offer and who may like to be present for the tender opening. Late and delayed offers are liable to be rejected.

VIGILANCE AWARENESS WEEK
26 th OCT to 31st OCT 2015
FOR VIGILANCE RELATED COMPLAINTS,
CONTACT DGM/VIGILANCE & SM/VIGILANCE
PHONE:0431-2577552,2577636

Yours faithfully,
For BHARAT HEAVY ELECTRICALS LIMITED

V. CHELLIAH
Sr Manager / Purchase
(FOSSIL BOILERS)
MM / RM / CP & SP
Yours faithfully,
BHEL, TRICHY : 620 014.

ALL DIMENSIONS ARE IN MILLIMETRES

3-M-12B25-15368

DRAWING NO.

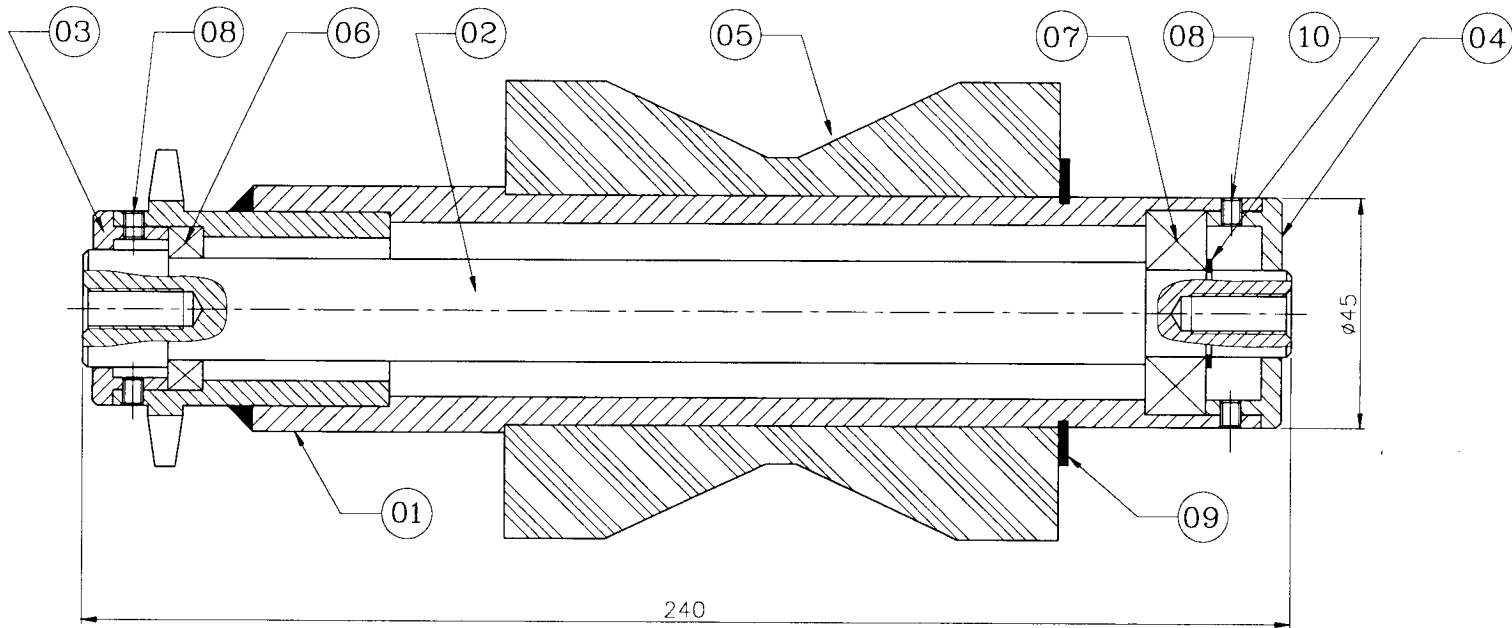

10	EXTERNAL CIRCLIP Ø17		IS 3075	-
				1
09	EXTERNAL CIRCLIP Ø45		IS 3075	-
				1
08	M4 x 8 LG SLOTTED GRUB SCREW		IS 1367	-
				4
07	BALL BEARING SKF 6203 2RS (Ø17 x Ø40 x 12)		-	-
				1
06	BALL BEARING SKF 61804 2RS (Ø20 x Ø32 x 7)		-	-
				1
05	'V' ROLLER	4-M-12B25-29833	-	-
				1

REV	DATE	ALTERED
		CHECKED
		APPROVED
ZONE		

CAUTION: THE INFORMATION ON THIS DOCUMENT IS THE PROPERTY OF BHARAT HEAVY ELECTRICALS LIMITED. IT MUST NOT BE USED DIRECTLY OR INDIRECTLY IN ANY WAY DETRIMENTAL TO THE INTEREST OF THE COMPANY.

04	BRG.END COVER -2	4M12B2529499	-	0.11
			-	1
03	BRG.END COVER -1	4M12B2529498	-	0.08
			-	1
02	TAPER ROLLER PIN	4M12B2529497	-	0.59
			-	1
01	TAPER ROLLER	3M12B2514963	-	2.13
			-	1
ITEM NO	DESCRIPTION	DRAWING NO	MATL CODE	UNIT WT
			MATL SPEC	QTY

EQPT: AUTO TUBE END CUTTING & PREPARATION (ATCEP)

	Bharat Heavy Electricals Ltd		DRN	N.MADURAIVEERAN	SIGNATURE	N. Maduraiveeran	DATE	24/12/14
	HIGH PRESSURE BOILER PLANT		CHD	R.RAMAMOORTHY	SIGNATURE	R. Ramamoorthy	DATE	24/12/14
	TIRUCHIRAPALLI - 620014		APPD	G.THAGARAJAN	SIGNATURE	G. Thiagarajan	DATE	24/12/14
DEPT	M&S	GRADE OF UNTOL. DIM	SCALE	WEIGHT (Kg)	REF TO ASSY DWG NO	ITEM		
CODE	2597	Ø/M/F IS. 2102	1:1	2.91	REF TO OLD DWG NO	-		
TITLE					CARD CODE	REV		
'V' ROLLER ASSY (BEVEL CONVEYOR)					U 01	-		

DRAWING NO : 3-M-12B25-15368

CAUTION: THIS DRAWING IS OUR SOLE PROPERTY AND SHOULD NOT BE USED IN ANY FORM FOR ANY PURPOSE WITHOUT THE WRITTEN PERMISSION OF BHARAT HEAVY ELECTRICALS LIMITED

ALL DIMENSIONS ARE IN MM

3.2 / 1.6

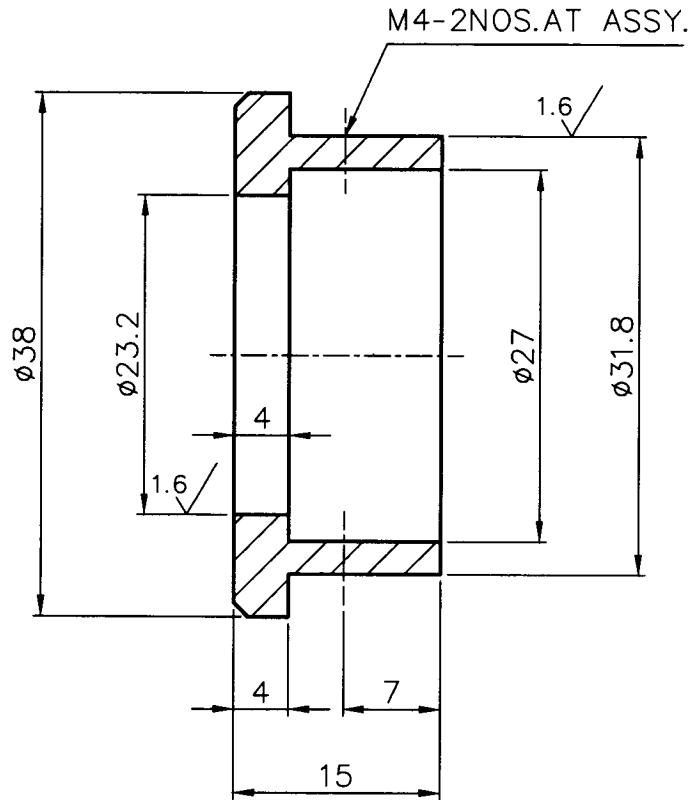

NOTE: -

1. SHARP CORNERS TO BE REMOVED

1	ROD $\phi 38 \times 15L$	45 C8	IS: 7283	0.08		
X	ASSY.				3M12B2514962	03
No. of Pieces	DESCRIPTION	MATERIAL	STANDARD	NET.WT.IN KGS.	DRAWING No.	ITEM No.
	REFERENCE:	ALTERATIONS:		DCN REF	DATE	SIGN.
SCALE	DRN.	N.Maduraiveeran				
1:1	CHD.	R.Ramamoorthy				
	APPD.	C.S.Jayasheelan				
	DATE	13.08.2012				
MACHINE: AUTO TUBE END CUTTING & PREPARATION			TYPE: ATCP,CEMA			
	TITLE: BRG.END COVER-1 (TAPER ROLLER CONVEYOR ASSY-CUTTING UNIT)			DRAWING No: 4 M 1 2 B 2 5 2 9 4 9 8		
Sheet No:				No. of Sheets:		

CAUTION: THIS DRAWING IS OUR SOLE PROPERTY AND SHOULD NOT BE USED IN ANY FORM FOR ANY PURPOSE WITHOUT THE WRITTEN PERMISSION OF BHARAT HEAVY ELECTRICALS LIMITED

ALL DIMENSIONS ARE IN MM

3.2 / 1.6

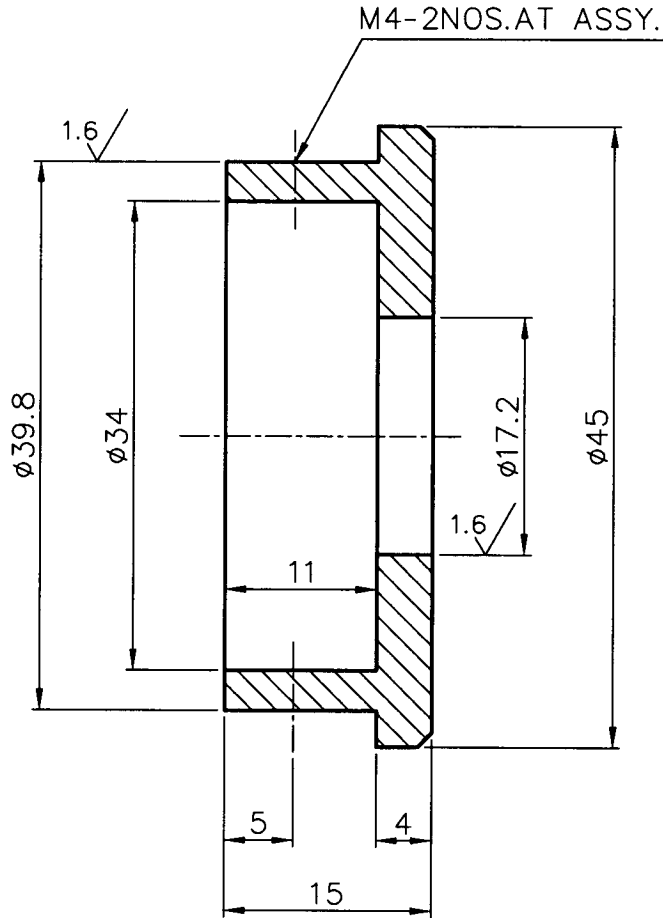

NOTE: -

1. SHARP CORNERS TO BE REMOVED

1	ROD $\phi 45 \times 15L$	45 C8	IS: 7283	0.11		
	ASSY.				3M12B2514962	04
No. of Pieces	DESCRIPTION	MATERIAL	STANDARD	NET.WT.IN KGS.	DRAWING No.	ITEM No.
	REFERENCE:		ALTERATIONS:	DCN REF	DATE	SIGN.
SCALE	DRN.	N.Maduraiveeran				
1:1	CHD.	R.Ramamoorthy				
	APPD.	C.S.Jayasheelan				
	DATE	13.08.2012				
	MACHINE: AUTO TUBE END CUTTING & PREPARATION	TYPE: ATCP,CEMA				
	TITLE:	BRG.END COVER-2		DRAWING No:		
	(TAPER ROLLER CONVEYOR ASSY-CUTTING UNIT)			4	M	12B2529499
		Sheet No:		No. of Sheets:		

ALL DIMENSIONS ARE IN MM

REV	DATE	ALTERED
		CHECKED
		APPROVED
ZONE		

NOTE: -

01. SHORE HARDNESS 80A ± 2

3.2/1.6

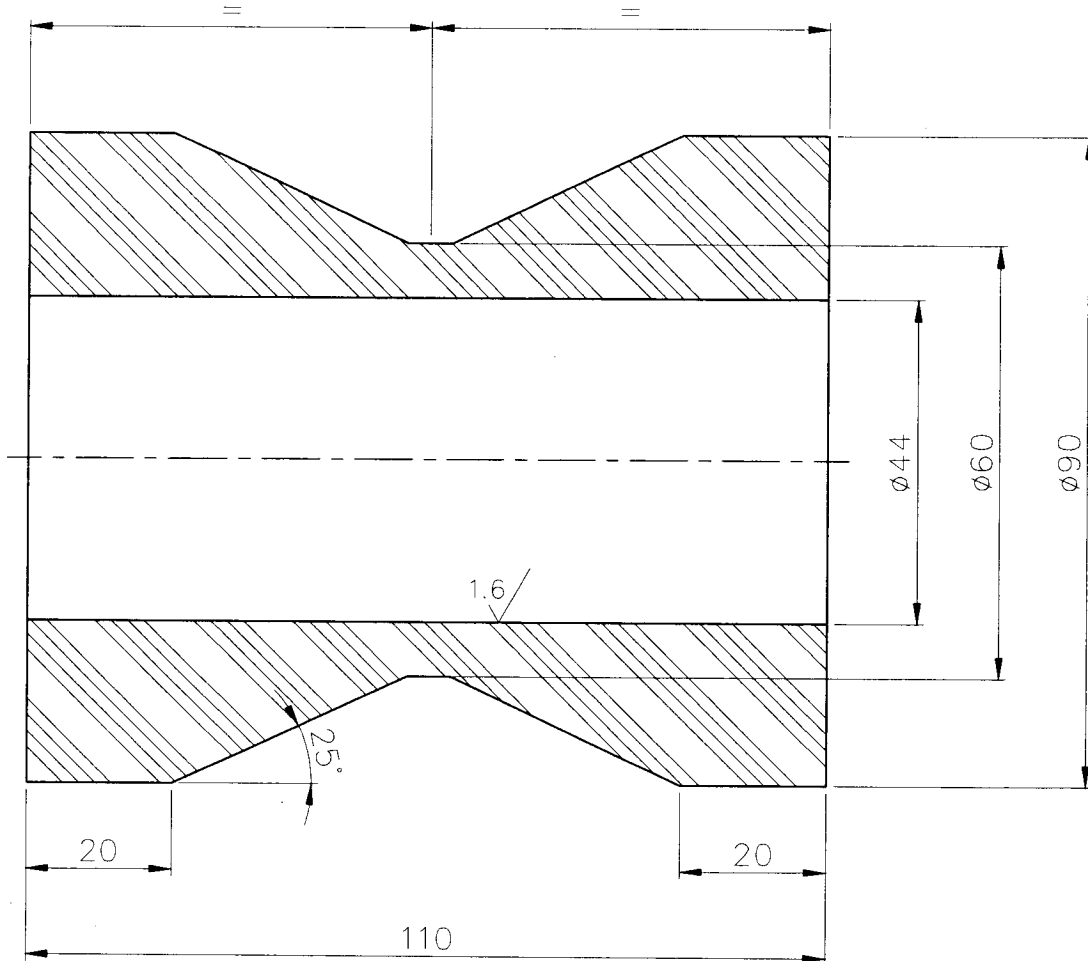

CAUTION: THE INFORMATION ON THIS DOCUMENT IS THE PROPERTY OF BHARAT HEAVY ELECTRICALS LIMITED. IT MUST NOT BE USED DIRECTLY OR INDIRECTLY IN ANY WAY DETRIMENTAL TO THE INTEREST OF THE COMPANY.

-	ø90 x 110	-	-	-	-
ITEM NO	DESCRIPTION	DRAWING NO	MATL CODE	UNIT WT	
			MATL SPEC	QTY	
EQPT: AUTO TUBE END CUTTING & PREPARATION (ATCEP)					
 Bharat Heavy Electricals Ltd HIGH PRESSURE BOILER PLANT TIRUCHIRAPALLI - 620014		DRN	NAME	SIGNATURE	DATE
		CHD	R.RAMAMOORTHY	<i>R. Ramamoorthy</i>	24/12/14
		APPD	G.THAGARAJAN	<i>G. Thiagarajan</i>	24/12/14
DEPT	GRADE OF UNTOL. DIM	SCALE	WEIGHT (Kg)	REF TO ASSY DWG NO	ITEM
M&S	Ø/M/F	1:1	-	3-M-12B25-15368	05
CODE	IS: 2102			REF TO OLD DWG NO	
2597				-	
TITLE			CARD CODE	DRAWING NO :	REV
'V' ROLLER SLEEVE (CHAMFERING STATION)			U 01	4-M-12B25-29833	00



A4-SIZE

ALL DIMENSIONS ARE IN MM

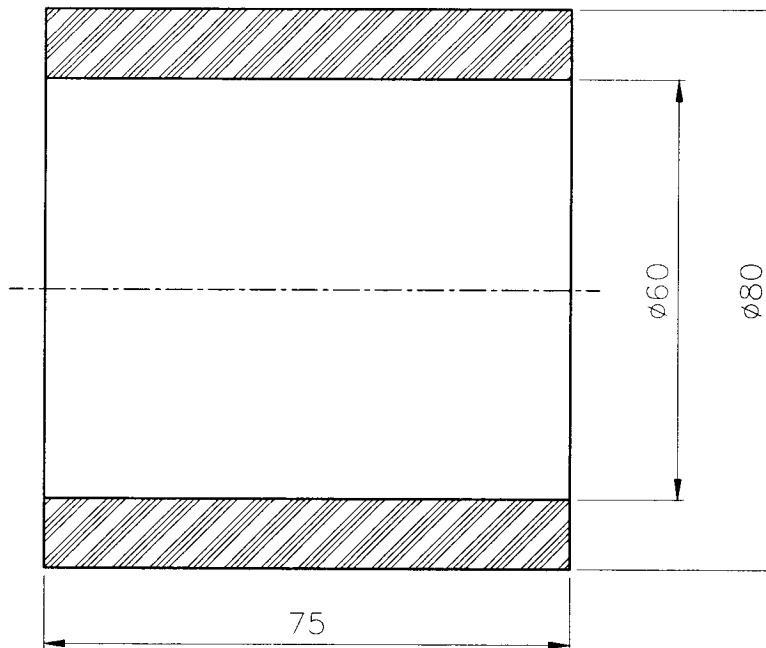
REV	DATE	ALTERED
		CHECKED
		APPROVED
ZONE		



CAUTION: THE INFORMATION ON THIS DOCUMENT IS THE PROPERTY OF BHARAT HEAVY ELECTRICALS LIMITED. IT MUST NOT BE USED DIRECTLY OR INDIRECTLY IN ANY WAY DETRIMENTAL TO THE INTEREST OF THE COMPANY.

	Ø80x75L						
					POLYURETHENE		
ITEM NO	DESCRIPTION	DRAWING NO			MATL CODE	UNIT WT	
					MATL SPEC	QTY	
EQPT: AUTOMATIC TUBE CUTTING & EDGE PREPARATION / ATCEP / PEMAMEK							
	Bharat Heavy Electricals Ltd HIGH PRESSURE BOILER PLANT TIRUCHIRAPALLI - 620014		DRN	NAME G.GOVINDARAJ	SIGNATURE <i>S. Govindaraj</i>	DATE 22.08.15	
			CHD	G.GOVINDARAJ	<i>S. Govindaraj</i>	22.08.15	
			APPD	G.THAGARAJAN	<i>S. Thiagarajan</i>	22.08.15	
DEPT M&S	GRADE OF UNTOL. DIM		SCALE 1:1	WEIGHT (Kg) -	REF TO ASSY DWG NO	ITEM	
CODE 2597	 IS: 21D2				REF TO OLD DWG NO		
TITLE SLEEVE Ø80x75L (GUIDE ROLLER)			CARD CODE U 01	DRAWING NO : 4-M-12B49-29863		REV 00	



A4-SIZE

ALL DIMENSIONS ARE IN MM

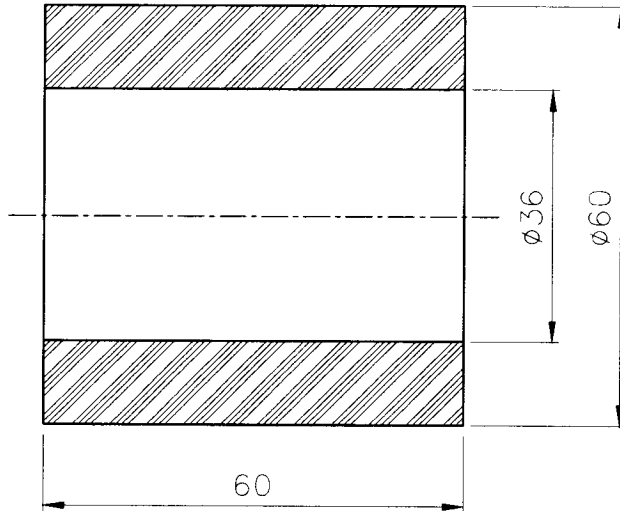
REV	DATE	ALTERED
		CHECKED
		APPROVED
ZONE		



CAUTION: THE INFORMATION ON THIS DOCUMENT IS THE PROPERTY OF BHARAT HEAVY ELECTRICALS LIMITED. IT MUST NOT BE USED DIRECTLY OR INDIRECTLY IN ANY WAY DETRIMENTAL TO THE INTEREST OF THE COMPANY.

Ø60x60L		POLYURETHENE		
ITEM NO	DESCRIPTION	DRAWING NO	MATL CODE	UNIT WT
			MATL SPEC	QTY
EQPT: AUTOMATIC TUBE CUTTING & EDGE PREPARATION / ATCEP / PEMAMEK				
 Bharat Heavy Electricals Ltd HIGH PRESSURE BOILER PLANT TIRUCHIRAPALLI - 620014	DRN	NAME G. GOVINDARAJ	SIGNATURE <i>S. Govindaraj</i>	DATE 22.08.15
	CHD	G. GOVINDARAJ	<i>S. Govindaraj</i>	22.08.15
	APPD	G. THIAGARAJAN	<i>S. Thiagarajan</i>	22.08.15
DEPT M&S	GRADE OF UNTOL. DIM ✓ Φ/M/F IS: 21D2	SCALE 1:1	WEIGHT (Kg) -	REF TO ASSY DWG NO
CODE 2597				REF TO OLD DWG NO
TITLE SLEEVE Ø60x60L (GUIDE ROLLER)		CARD CODE U 01	DRAWING NO : 4-M-12B49-29864	
			REV	00

A4-SIZE

CAPITAL PURCHASE
COMMERCIAL TERMS AND CONDITIONS

1.0 QUOTATIONS

The Bidders shall submit the offer in **TWO INNER ENVELOPES** as indicated below which shall be sealed in one outer envelope.

Envelope I This sealed envelope should contain all the copies of technical bid together with un-priced commercial bid & annexure III. This envelope should be clearly marked **'Part I - Technical and commercial bid'**,

Indicating Enquiry No., Due Date and Address & Reference of the Bidder.

Envelope II This sealed envelope should contain **price as per Annexure-IV format**. This envelope should be clearly marked **"Part II - Price bid"**, indicating **Enquiry No., Due Date and Address & Reference of the Bidder**.

Both the envelopes (Part I & II) shall be put in one cover (**Envelope III**), duly sealed, superscribing as Part I and Part II of Enquiry No., due date of opening and the address and reference of the Bidder

The above offer should reach this office on or before the due date by 14.00 hours (IST). Late offers will not be considered.

Tender should not be addressed to any individual's name

The Tender Opening Cell/MM
Room No-26 , Building – 24 , Ground Floor
Bharat Heavy Electrical Limited
Tiruchirapalli- 620014 .

Tenders should be free from **CORRECTION AND ERASURES**, Corrections if any, must be attested. All Amounts shall be indicated both in words as well as in figures. Where there is difference between amount quoted in words and figures, amount quoted in words shall prevail.

Offers should be in **ENGLISH** and accompanied by detailed technical literature, catalogue and detailed dimensional drawings in **ENGLISH** or otherwise, the offers will not be considered.

2.0 OPENING OF TENDERS

The Part I - Technical & commercial bid alone would be opened on the Tender opening date.

The Part II - Price bid of technically suitable Bidders alone would be opened. The Technically Suitable Bidders would be informed about the tender opening date through e-mail.

Clarifications if any required by BHEL for Technical evaluation **would be** sought from Bidders before opening of Part II - price bid

For any queries clarifications the bidders may contact us through our FAX NO. +91 431 2520719 or through e-mail <arunachal@bheltry.co.in >&< chells@bheltry.co.in>

Annexure For Techno Commercial Bid

Check List - to be filled and submitted along with Technical Bid

BHEL Commercial Terms and Conditions for Indigenous Supplies	Vendor's Confirmation / Comments
Technical confirmation to BHEL's Specification as called for in BHEL Format shall be furnished. If needed additional sheets shall be used.	
Prices shall be quoted item wise only as per the model format enclosed	
Prices shall be quoted on " FIRM PRICE " basis only The prices should be only on F.O.R / Despatching station basis with Packing & Forwarding charges if any. Applicable % of ED & Sales Tax, Freight & Insurance, Installation & Commissioning Charges should be clearly Indicated	
Validity of offer shall be for a minimum period of 120 days from the date of Tender opening	
Delivery period from the date of Letter of Intent / Purchase order shall be clearly mentioned in the offer	
Liquidated damages @ 0.5% per week subject to a maximum of 10% of the order value shall be applicable for delay in deliveries For Details Refer Annexure- v	
Following Risk Purchase clause shall be applicable The purchaser at his option will be entitled to terminate the contract and to purchase elsewhere at the risk and cost of the seller either the whole of the goods or any part which the supplier has failed to deliver or dispatch within the time stipulated or if the same were not available, the best and the nearest available substitute therefore The supplier shall be liable for any loss which the Purchaser may sustain by reason of such risk purchases	
Payment term for supply portion: Payment term is 100% direct payment after 45 days from the date of receipt and acceptance of materials For details Refer Annexure- v	
Erection / commissioning: (if applicable only) Erection / commissioning charges if any has been mentioned in the offer or else confirmation that Erection /commissioning shall be done at free of cost is available in the offer,	
The equipment shall be guaranteed for a period of 12 months from the date of commissioning	
Final inspection and acceptance of equipment will be after installation at BHEL, Trichy	
The vendor shall provide necessary drawings, Test Certificates and Operating Maintenance Manuals etc., as called for in the Technical Specification, in the required number of copies at no extra cost	
Any warranty replacement during warranty period shall be supplied free of charge on FOR BHEL, Trichy basis.	
Offers should be submitted only in sealed cover super-scribing clearly the Enquiry reference and due date.	
% of Excise Duty with cess	
% of TAX (CST/VAT)-(INGST with FORM-17 or CST with C-FORM)	
Packing & Forwarding Charges (if any in % only)	
Percentage of Freight& transit insurance charges, if any Freight charges from Dispatching station to BHEL, Tiruchirappalli • Supplier should quote for F.O.R-BHEL Trichy Stores.	
As per Commercial terms and conditions, acceptance for participation in Reverse auction (RA).Yes/No to be indicated	
Name of the person for participating reverse auction	
Land Line Number	
Fax Number	
Mobile Number	
E-mail ID	

NOTE:-

- It is confirmed that all the terms and conditions stipulated In the Enquiry have been fully understood by us and all clarifications & details have been obtained.
- Your offer should be indicating applicable If any P&F Charges, % of ED, Sales Tax -CST or VAT, Service Tax), Freight, Insurance and Installation and Commissioning Charges etc., as per our Price Format
- Your specific acceptance to our Payment terms, LD & Risk Purchase Clause are essential for consideration of your offer. Other wise your offer is liable for rejection.
- No row shall be left blank. Please indicate NA, in case the item is "not applicable"

Annexure For Price Bid

**Bharat Heavy Electricals Limited TIRUCHIRAPPALLI CAPITAL PURCHASE
MODEL PRICE BID FORMAT FOR INDIAN BIDDERS**

Annexure-IV

Enquiry No. & Date:

Bidder's Offer No. & Date:

Sl No	Description of item	Unit	Quantity	Rate in Rs.	Value in Rs.
	TOTAL VALUE IN RS.				
	Packing & Forwarding charges in % if any				
	Freight & Insurance Charges In % if freight charges are not mentioned it will be considered as FOR-BHEL TRICHY.				
	Excise Duty (indicate in %)				
	A) TNGST — VAT (%)				
	B) CST with C-FORM — (%)				
	C) CST without C-Form — (%)				
	Approximate Net weight of the total consignment				
	Approximate Gross weight of the total consignment				
	Approximate Dimensions of the Consignment				
	The price indicated shall be inclusive of all accessories, spares etc. as given in the scope of supply. Individual item-wise break-up price shall be attached as an annexure to this price bid format.				

Signature & Seal of Vendor

NOTE:

1. The price bid should be submitted only as per the above format. No row shall be left blank. Please indicate NA, in case the item is "not applicable".
2. Prices shall be quoted item-wise only as per the above format.
3. If Price quoted is Inclusive of ED, the included ED Value and Base Value shall be indicated item-wise.

Payment Term (Indigenous)	
If materials are receivable at Stores/Trichy <u>without</u> PBG	Payment term is 100% direct payment after 45 days from the date of receipt and acceptance of materials.
If materials are receivable at Stores/Trichy <u>with</u> PBG	Payment term is 100% direct payment after 45 days from the date of receipt and acceptance of materials and against 10% PBG valid for the warranty period.
Any deviation in the above payment term will attract loading as mentioned below. “Base rate of SBI (as applicable on the date of bid opening. Techno-commercial bid opening in case of two part bids) + 6% shall be considered for loading for the period of relaxation sought by bidders.	

Offers of indigenous Suppliers with any other Payment terms will be rejected.

Liquidated Damages / Penalty -

The delivery of the goods specified in the purchase order should be made within the time prescribed. LD for delay in 'Supply' and/or 'E&C' will be applicable to the delays attributed to vendor. LD will be considered separately for 'Delivery' and 'E&C'. Where the seller supplies or dispatches the goods, beyond the delivery period Liquidated damages shall be applicable 0.5% of the total order value per week or part thereof subject to a maximum of 10% of the total order value.

Material Despatched after Due date: Once the delivery due date is crossed, bills have to be clubbed till final despatch and forwarded for processing of payment as a single bunch. LD percentage will be calculated from Delivery due date to final despatch date.

The rate of LD for delayed E&C shall be @ 0.5% per week of delay of total PO value (Supply + E&C) in E&C subject to a maximum of 10% of total PO value (Supply + E&C).

For staggered delivery schedule, LD shall be 0.5% of the undelivered portion per week of the delay or part thereof subject to a maximum of 10% of the total order value.

Any deviation from the above LD clause, loading will be applied to the extent to which it is not agreed by the bidder (at offered value).

For the purpose of Imposing LD, the FOB delivery (B/L date) shall be considered.

Guarantee / Warranty Period – (if applicable)

Normally No deviation permitted and the deviated offers are liable for rejection.

Ranking-

BHEL will consider the ranking after the loading is applied as referred above wherever deviations are observed.

Performance Bank Guarantee – (if applicable)

Normally No deviation permitted and the deviated offers are liable for rejection.

Fraud prevention clause: The bidder along with its associate/collaborator/sub-contractor/sub-vendor/consultants/service providers shall strictly adhere to BHEL fraud prevention policy displayed on BHEL website <http://www.bhel.com> and shall immediately bring to the notice of BHEL management about any fraud or suspected fraud as soon as it comes to their notice.

NOTE:-

1. If the due date of tender opening happens to be a holiday, the tenders will be opened on the next working day.
2. BHEL reserves the right to go for a reverse auction (RA) instead of opening the submitted sealed bid which will be decided after technical evaluation. Information and general terms and conditions covering RA are given in commercial terms and conditions.
3. Corrigendum if any, with respect to this tender will be hosted only in the website <http://www.bhel.com> or <http://tenders.gov.in>. You are requested to visit the website regularly for updates.

Special Provisions for Micro and Small Enterprises (MSE)

1. 20% of the tendered quantity is earmarked for MSE suppliers in this tender.
2. Out of the 20% tendered quantity reserved for MSE suppliers, 4% shall be earmarked for procurement from MSE owned by SC/ST entrepreneurs.
3. In case MSE vendor participating in the tender quotes within the price band of L1+15%, they will be allowed to supply the portion of the requirement subject to acceptance of L1 price by MSE vendor. In case of more than one such MSE, the supply shall be shared proportionately.
4. "MSE suppliers can avail the intended benefits only if they submit along with the offer, attested copies of either EM II certificate having deemed validity (five years from the date of issue of acknowledgement in EM-II) or valid NSIC certificate or EM II certificate along with attested copy of a CA certificate (Format enclosed at Annexure -VII where deemed validity of EM II certificate of five Years has expired) applicable for the relevant financial year (latest audited). Date to be reckoned for determining the deemed validity will be the date of bid opening (Part 1 in case of two part bid). Non submission of such documents will lead to consideration of their bid at par with other bidders. No benefit shall be applicable for this enquiry if any deficiency in the above required documents are not submitted before price bid opening. If the tender is to be submitted through e-procurement portal, then the above required documents are to be uploaded on the portal. Documents should be notarized or attested by a Gazetted officer."

Certificate by Chartered Accountant on letter head

This is to Certify that M/S
(hereinafter referred to as 'company') having its registered office at
..... is registered under MSMED Act 2006, (Entrepreneur
Memorandum No (Part-II) dtd:.....,
Category: (Micro/Small)). (Copy enclosed).

Further verified from the Books of Accounts that the investment of the company as on
date..... as per MSMED Act 2006 is as follows:

1. **For Manufacturing Enterprises:** Investment in plant and machinery (i.e. original cost excluding land and building and the items specified by the Ministry of Small Scale Industries vide its notification No.S.O.1722(E) dated October 5, 2006 :
Rs.....Lacs
2. **For Service Enterprises:** Investment in equipment (original cost excluding land and building and furniture, fittings and other items not directly related to the service rendered or as may be notified under the MSMED Act, 2006:
Rs.....Lacs

The above investment of Rs.....Lacs is within permissible limit of
Rs.....Lacs forMicro / Small (Strike off which is not applicable)
Category under MSMED Act 2006.

Date:

(Signature)

Name -

Membership number -

Seal of Chartered Accountant