



# BHARAT HEAVY ELECTRICALS LIMITED

( A Government of India Undertaking )  
HIGH PRESSURE BOILER PLANT  
PURCHASE DEPARTMENT - FOSSIL BOILERS  
THIRUCHIRAPALLI - 620014  
TAMILNADU (INDIA)

Page 1/4  
PHONE :2577938  
GRAMS : BHARATELEC  
FAX NO: 2520719  
E-mail: tvenkat@bheltry.co.in  
Web:

429-002/A

	<b>Enquiry No</b>	<b>Enquiry Date</b>	<b>Due Date for Quotation</b>
	2661500552 - 46	18.12.2015	12.01.2016
<p>Please quote Enquiry No, Date and due date in all correspondences. This is only a request for quotation and not an order. <b>Bid should be submitted in two parts. 1.Techno-commercial bid (Part-I) and 2.Price bid(Part-II) in a separate sealed cover and both covers must be placed in a third cover and sealed. Our Enquiry No., Enq. date &amp; Enq. Due date must be written on all three covers.</b></p>			

Item	Description	Unit	Quantity	Delivery Quantity	Schedule Date
10	<p>BOTTOM BRICK AS PER DRG. NO. 3M-18A-03-11870. COMMON NOTE FOR ITEM 10 TO 200: (1) MATERIALS SHOULD BE CRACK FREE AND MATERIAL WITH CRACKS AT BHEL ,TRICHY WILL NOT BE ACCEPTED. (2) TEST CERTIFICATE FOR MATERIAL CONFIRMITY AS PER DRAWING FROM GOVT. APPROVED LAB / LAB WITH ISO 9001-2008 CERTIFICATION SHALL BE PRODUCED DURING PRE-DESPATCH INSPECTION. (3) MATERIALS SHOULD BE SUPPLIED ALONG WITH ORIGINAL TEST CERTIFICATE. (4) BRICKS SHOULD HAVE IDENTIFICATION MARK LIKE MANUFACTURER COMPANY NAME AND BHEL DRAWING NUMBER(LAST FIVE DIGITS) ON IT. (5) ALL ITEMS HAVE TO BE OFFERED TO BHEL ENGINEER FOR PRE-DESPATCH INSPECTION AT VENDOR'S WORKS. (6) PREFERABLE DELIVERY PERIOD IS TO BE WITHIN 12 WEEKS FROM THE DATE OF PURCHASE ORDER. VENDOR QUALIFYING CRITERIA: Only those vendors who satisfy the following conditions will get qualified to participate in the tender: (1) Only those vendors, who have Supplied refractory items for atleast to one company in the past seven years for which supporting documents like PO copies are to be submitted along with offer. (2) The vendor should submit following details which are necessary for qualifying their offer: (a)Name and postal address of the customer / company where refractory items were supplied. (b)Name and designation of the contact person of the customer. (c)Phone no. and Email address of the contact person of the customer. (3) BHEL reserves the right to verify the information provided by vendor.In case the information provided by</p>	NO	30.000	30.00	30.05.16

The offers should reach us 30 minutes before the time of opening of tenders. The offers will be opened at 14.30 hrs on the due date of tender in the presence of tenderers who have submitted their offer and who may like to be present for the tender opening.Late and delayed offers are liable to be rejected.

Yours faithfully,  
For BHARAT HEAVY ELECTRICALS LIMITED

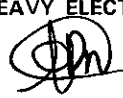
  
**ARUN PRASATH. N**  
Senior Engineer / MANAGER / PURCHASE  
Purchase (CP & SP) / MM-FOSSIL BOILERS)  
BHEL, TIRUCHY - 620 014  
Yours faithfully,



# BHARAT HEAVY ELECTRICALS LIMITED

( A Government of India Undertaking )  
HIGH PRESSURE BOILER PLANT  
PURCHASE DEPARTMENT - FOSSIL BOILERS  
THIRUCHIRAPALLI - 620014  
TAMILNADU (INDIA)

PHONE :2577938  
GRAMS : BHARATELEC  
FAX NO: 2520719  
E-mail: tvenkat@bheltry.co.in  
Web:

2661500552 / 18.12.2015

23505

vendor is found to be false /  
incorrect, the offer shall be rejected.

20	COVER AS PER DRG. NO. 4M-1BA-03-26328.	NO	30.000	30.00	30.05.16
30	SIDE BRICK AS PER DRG. NO. 4M-18A-03-27812	NO	40.000	40.00	30.05.16
40	TOP BRICK AS PER DRG. NO. 4M-18A-03-28227	NO	25.000	25.00	30.05.16
50	COVER AS PER DRG. NO. 4-M-18A-04-27033-01.	NO	50.000	50.00	30.05.16
60	SIDE FIRE BRICK AS PER DRG. NO. 4-M-18A-04-27813	NO	24.000	24.00	30.05.16
70	ARCH REFRACTORY BRICK AS PER DRG. NO. 4M-18A-04-26866.	NO	100.000	100.00	30.05.16
80	BOTTOM FIRE BRICKS AS PER DRG. NO. 3M-18A-13-0173.	NO	8.000	8.00	30.05.16
90	SIDE FIRE BRICKS AS PER DRG. NO. 3M-18A-13-0172.	NO	8.000	8.00	30.05.16
100	TOP ARCH FIRE BRICKS AS PER DRG. NO. 3M-18A-13-0171.	NO	4.000	4.00	30.05.16
110	BOTTOM FIRE BRICK AS PER DRG. NO. 3M-18A-05-13827	NO	12.000	12.00	30.05.16
120	SIDE FIRE BRICK AS PER DRG. NO. 3M-18A-05-0587	NO	24.000	24.00	30.05.16
130	TOP FIRE BRICK AS PER DRG. NO. 3M-18A-05-0588	NO	12.000	12.00	30.05.16
140	ARCH BRICK AS PER DRG. NO. 4M-18A-1B-28436.	NO	10.000	10.00	30.05.16
150	CERAMIC BUSH AS PER DRG. NO. 4M-18A-22-26024	NO	100.000	100.00	30.05.16
160	CERAMIC WASHER AS PER DRG. NO. 4M-18A-22-26218	NO	100.000	100.00	30.05.16
170	CERAMIC TUBE AS PER DRG. NO. 4M-18A-22-26219	NO	100.000	100.00	30.05.16
180	SHAPED BRICK AS PER DRG.NO. 4M-18D-07-22244.	NO	600.000	600.00	30.05.16

The offers should reach us 30 minutes before the time of opening of tenders.  
The offers will be opened at 14.30 hrs on the due date of tender in the presence of  
tenderers who have submitted their offer and who may like to be present for the tender  
opening.Late and delayed offers are liable to be rejected.

Yours faithfully,  
For BHARAT HEAVY ELECTRICALS LIMITED

**ARUN PRASATH. N**  
Senior Engineer  
Purchase ( CP & SP ) / MR  
BHEL, TIRUCHY - 620 014.

  
MANAGER / PURCHASE  
(FOSSIL BOILERS)  
Yours faithfully,



# BHARAT HEAVY ELECTRICALS LIMITED

( A Government of India Undertaking )  
HIGH PRESSURE BOILER PLANT  
PURCHASE DEPARTMENT - FOSSIL BOILERS  
THIRUCHIRAPALLI - 620014  
TAMILNADU (INDIA)

PHONE :2577938  
GRAMS : BHARATELEC  
FAX NO: 2520719  
E-mail: tvenkat@bheltry.co.in  
Web:

2661500552 / 18.12.2015

23505

190	NO	150.000	150.00	30.05.16
BOGIE SIDE BRICK AS PER DRG.NO. 4M-18D-10-28949.				
200	NO	300.000	300.00	30.05.16
CAR SIDE BRICK AS PER DRG.NO. 4M-18D-03,04-0626.				

### General Note:

#### Important note:

YOU SHOULD CONFIRM LD CLAUSE, VALIDITY , PAYMENT TERMS AND DELIVERY PERIOD AS PER BHEL COMMERCIAL TERMS AND CONDITIONS. OTHERWISE YOUR OFFER WILL BE REJECTED.

ENCLOSURES : (i) DRAWINGS &  
.....(ii) ANNEXURE - 'A':- COMMERCIAL TERMS AND CONDITIONS MUST BE FILLED AND SUBMITTED ALONG WITH TECHNO COMMERCIAL BID.

All the tenders may be addressed to the following address:

**The Tender Opening Cell / MM  
Room No: 26, Building 24, Ground Floor  
Bharat Heavy Electricals Limited  
TIRUCHIRAPALLI 620014**

In case personal delivery of the offer, it shall be dropped into the respective box kept in Room No: 26, after duly entering the data in the system.

Offers will be accepted only up to 14.00 Hrs on the due date. Therefore, vendors shall ensure to submit the offers well before this time. All due date extension requirements should be addressed to the respective Purchase mail IDs. All the due date extension requests from vendors will be considered only up to 48 hours before the due date and time.

Vendors are requested to avoid submission of offers through e mail / fax. In case of any unavoidable situation, offers shall be sent through e mail to the following mail ID only tender\_cell@bheltry.co.in.

As tenders are being opened by Common Tender Opening Cell, offer covers should be sealed with tenderer's distinctive seal and super scribed with correct Tender No. item of supply and due date of opening.

The offers will be opened at 14.30 hrs on the due date of the tender in the presence of tenderers who have submitted their offer and who may like to be present for the tender opening. Late and delayed offers are liable to be rejected.

**The bidder along with its associate/ collaborators/ sub-contractors/ sub-vendors/ consultants/ service providers shall strictly adhere to BHEL fraud prevention policy displayed on BHEL website <http://www.bhel.com> and shall immediately bring to the notice of BHEL management about any fraud or**

The offers should reach us 30 minutes before the time of opening of tenders.  
The offers will be opened at 14.30 hrs on the due date of tender in the presence of tenderers who have submitted their offer and who may like to be present for the tender opening. Late and delayed offers are liable to be rejected.

Yours faithfully,  
For BHARAT HEAVY ELECTRICALS LIMITED

**ARUN PRASATH. N**  
Senior Engineer  
Purchase ( CP & SP ) / MM / RM  
BHEL, TIRUCHY - 620 014.

MANAGER / PURCHASE  
(FOSSIL BOILERS)  
Yours faithfully,



# BHARAT HEAVY ELECTRICALS LIMITED

( A Government of India Undertaking )  
HIGH PRESSURE BOILER PLANT  
PURCHASE DEPARTMENT - FOSSIL BOILERS  
THIRUCHIRAPALLI - 620014  
TAMILNADU (INDIA)

PHONE :2577938  
GRAMS : BHARATELEC  
FAX NO: 2520719  
E-mail: tvenkat@bheltry.co.in  
Web:

Page  
4/4

2661500552 / 18.12.2015

23505

suspected fraud as soon as it comes to their notice.

Enclosures:

"LD clause has to be confirmed without fail."

The offers should reach us 30 minutes before the time of opening of tenders.  
The offers will be opened at 14.30 hrs on the due date of tender in the presence of  
tenderers who have submitted their offer and who may like to be present for the tender  
opening.Late and delayed offers are liable to be rejected.

Yours faithfully,  
For BHARAT HEAVY ELECTRICALS LIMITED

**ARUN PRASATH. N**  
Senior Engineer  
Purchase ( CP & SP ) / M.M.  
BHEL, TIRUCHY - 620 014.

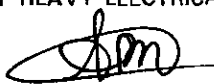
  
MANAGER / PURCHASE  
(FOSSIL BOILERS)  
Yours faithfully,

ALL DIMENSIONS ARE IN MM

**CAUTION:** THIS DRAWING IS OUR SOLE PROPERTY AND SHOULD NOT BE USED IN ANY FORM FOR ANY PURPOSE WITHOUT THE WRITTEN PERMISSION OF BHARAT HEAVY ELECTRICALS LIMITED TRICHIRAPPALLI - 620 014.

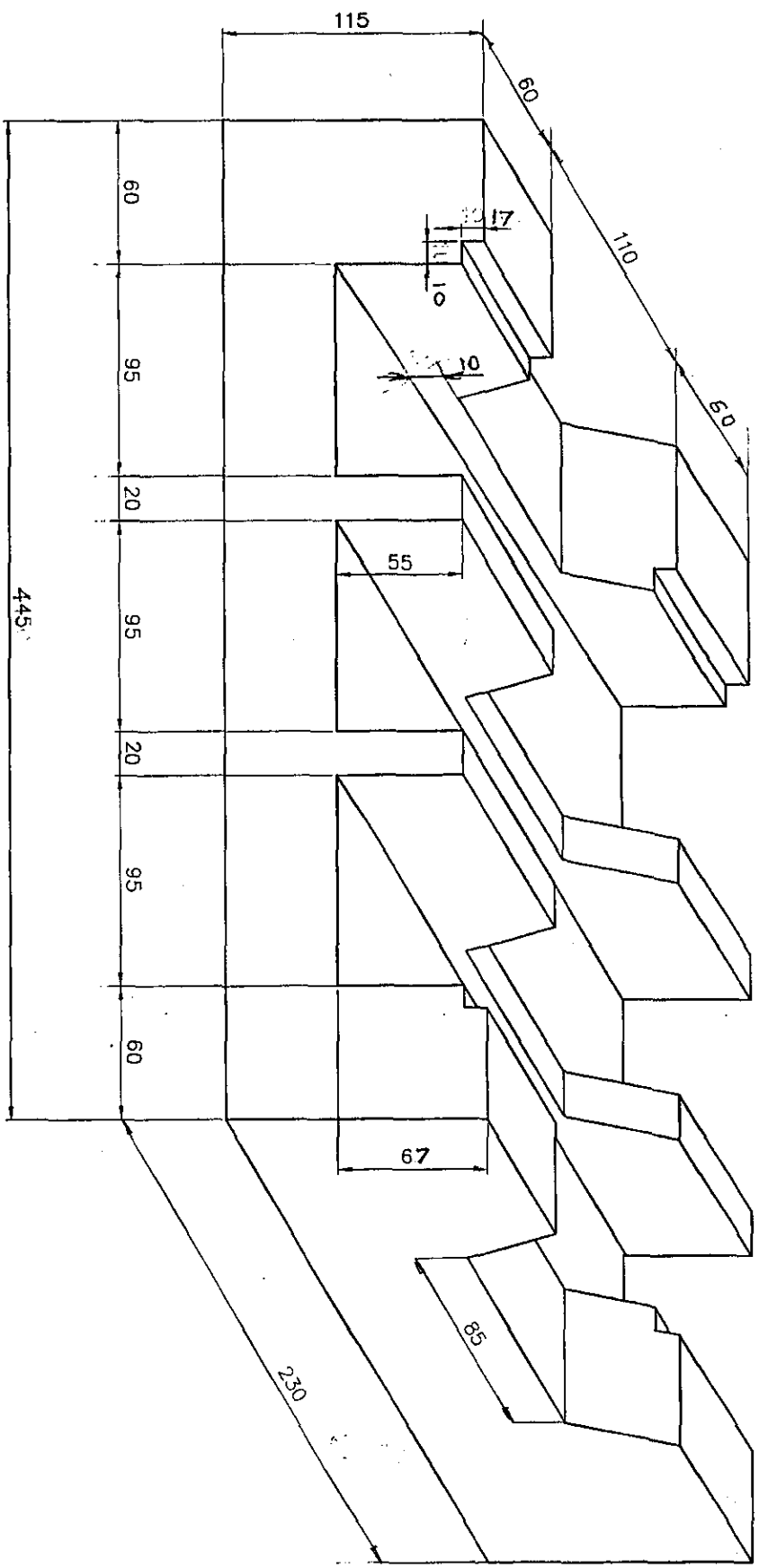

**NOTE :-**

MATERIAL SILIMINITE WITH FOLLOWING

**SPECIFICATIONS:**

- Al<sub>2</sub>O<sub>3</sub> - 61%
- SiO<sub>2</sub> - 36.5%
- Fe<sub>2</sub>O<sub>3</sub> - 1.5%
- AP - 20%
- CCS - 400 Kg/cm<sup>2</sup> (MIN)%
- PCE - 36 (ORTON CONE)

X	NO. OF REVISIONS	DESCRIPTION	MATERIAL	STANDARD	NET WT IN KGS.	DRAWING NO.	TIER NO.
	REFERENCE			COMPONENT CODE: 00		EQUIPMENT CODE: 03	
SCALE		DRAWN	CHECKED	APPROVED	DATE	INDEX	
MACHINE/ROD HEATING FURNACE		TYPE/THE REL. E.K. - 4-50 KW		DRAWING No.		REV.	
TITLE		BOT TOM BRICK		3-OM-18A-11870		03	
DATE		12-10-29		No. of Sheets		Sheet No.	

11/1/1

CAUTION: THIS DRAWING IS OUR SOLE PROPERTY AND SHOULD NOT BE USED IN ANY FORM FOR ANY PURPOSE WITHOUT THE WRITTEN PERMISSION OF BHARAT HEAVY ELECTRICALS LIMITED TRICHIRAPPALLI - 620 014.

ALL DIMENSIONS ARE IN MM

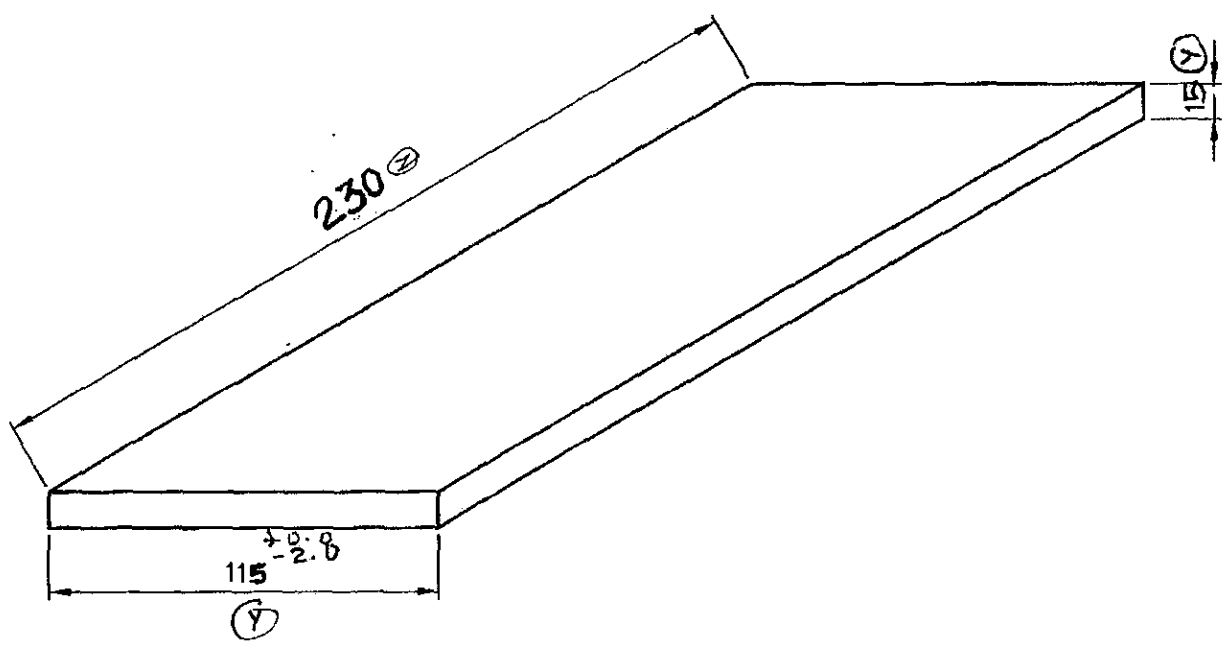
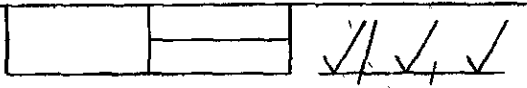

NOTE :- MATERIAL SHOULD BE MANUFACTURED TWIST FREE.

\* MATERIAL SILLIMANITE WITH FOLLOWING SPECIFICATIONS.

- Al<sub>2</sub>O<sub>3</sub> - 61%.
- SiO<sub>2</sub> - 36.5%.
- Fe<sub>2</sub>O<sub>3</sub> - 1.5%.
- Ap - 20%.
- CCS - 400 Kg/cm<sup>2</sup> (MIN) %.
- PCE - 36 (ORTON CONE)

		*							
X									
Noof Pieces	DESCRIPTION			MATERIAL	STANDARD	NET.WT.IN KGS.	DRAWING No.		ITEM No.
REFERENCE:	SKS-200117-97-B				COMPONENT CODE: 00	EQUIPMENT CODE: 03			
SCALE	DRAWN	DIMENSIONS 230 X 115 X 15			ALTERATIONS:	DCN REF	DATE	SIGN.	INDEX
1:2	CHECKED	DIM 115, 115 WAS 110, 10					20/10/21	RLM	Y
	APPROVED	* MATL. WAS SILICON CARBIDE							X
	DATE	14/12/98					IS: 2044		
MACHINE: ROD HEATING FURNACE					TYPE: THERELEK. 450 KW				
TITLE: COVER (115X230X15t)					DRAWING No: 03			REV.	
					4-M-18A-26328				
					Noof Sheets		Sheet No		

CAUTION: THIS DRAWING IS OUR SOLE PROPERTY AND SHOULD NOT BE USED IN ANY FORM FOR ANY PURPOSE WITHOUT THE WRITTEN PERMISSION OF BHARAT HEAVY ELECTRICALS LIMITED

ALL DIMENSIONS ARE IN MM

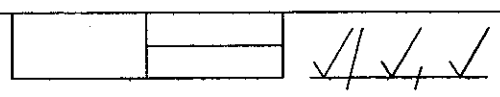
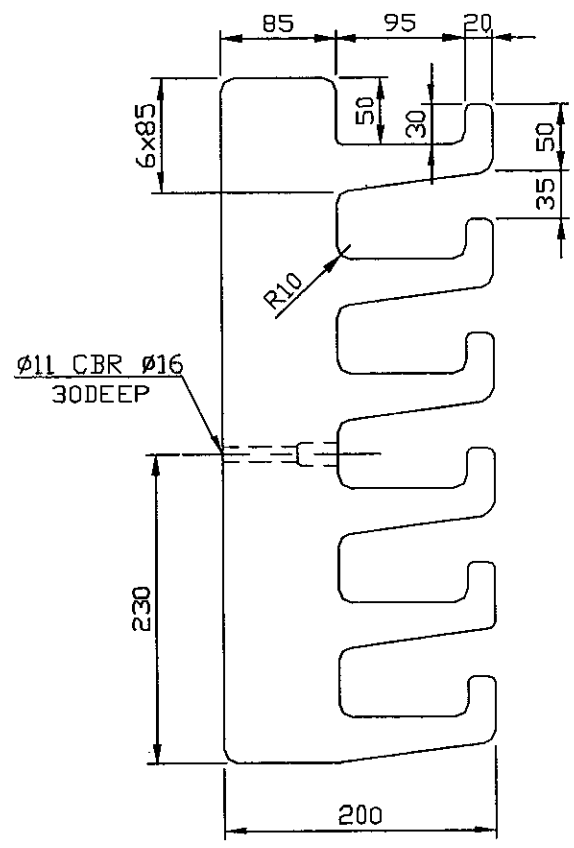
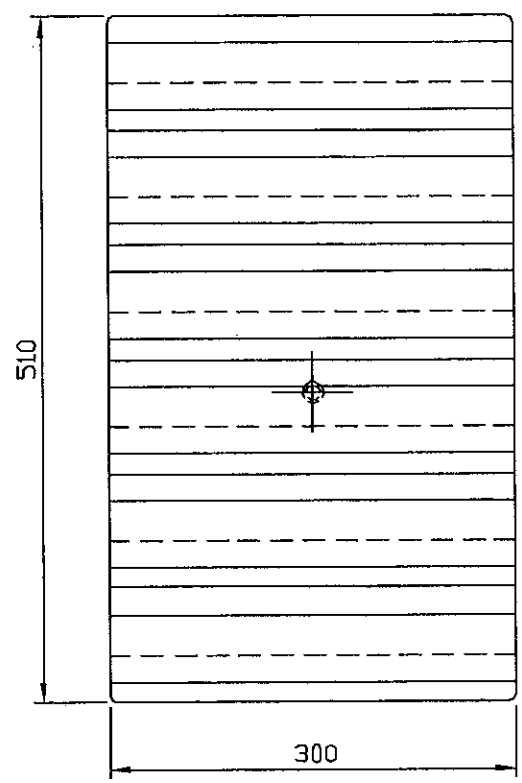

NOTE:

MATERIAL: SILLIMANITE WITH FOLLOWING SPECIFICATIONS.

- Al<sub>2</sub> O<sub>3</sub> - 61%
- Si O<sub>2</sub> - 36.5%
- Fe<sub>2</sub> O<sub>3</sub> - 1.5%
- Ap - 20%
- CCS - 400kg/cm (MIN)%
- PCE - 36 (ORTON CONE)

No of Pieces		DESCRIPTION	MATERIAL	STANDARD	NET.WT.IN KGS.	DRAWING No.	ITEM No.
REFERENCE:		ALTERATIONS:		DCN REF	DATE	SIGN.	INDEX
SCALE 1 : 5	DRAWN	K.MANIKANDAN					
	CHECKED	R.RAMAMOORTHY					
	APPROVED	C.S.JAYASHEELAN					
	DATE	10.03.06					
MACHINE: ROD HEATING FURNACE				TYPE: ELHEAT 450KW			
TITLE: <b>SIDE BRICK</b> (FOR ELEMENT HOLDING)				DRAWING No: <b>4M18A0327812</b>		REV.	
Sheet No:				No. of Sheets:			



CAUTION: THIS DRAWING IS OUR SOLE PROPERTY AND SHOULD NOT BE USED IN ANY FORM FOR ANY PURPOSE WITHOUT THE WRITTEN PERMISSION OF BHARAT HEAVY ELECTRICALS LIMITED

ALL DIMENSIONS ARE IN MM

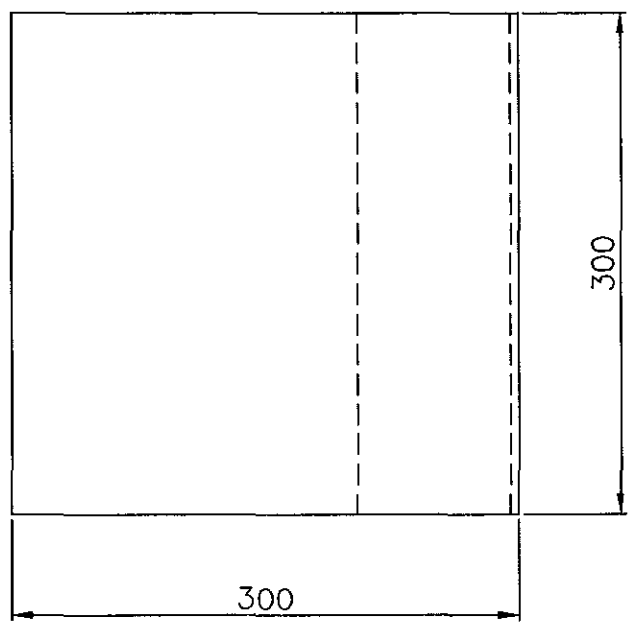
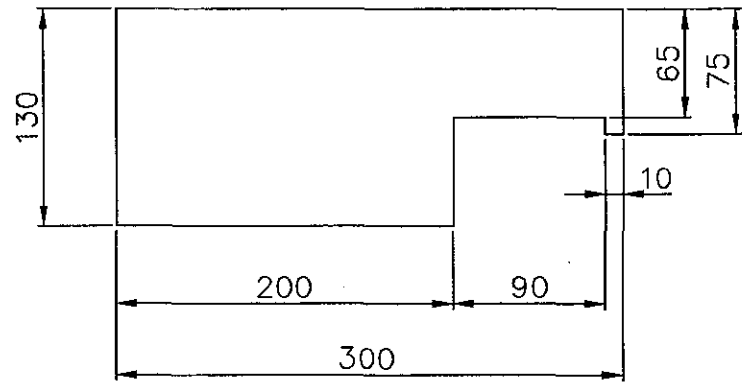
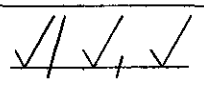

NOTE: -

\* MATERIAL SILLIMANITE WITH FOLLOWING SPECIFICATION.

- Al<sub>2</sub>O<sub>3</sub> - 61%
- Si O<sub>3</sub> - 36.5%
- Fe<sub>2</sub>O<sub>3</sub> - 1.5%
- AP - 20%
- CCS - 400KG/CM (MIN)%
- PCE - 36 (ORTON CONE)

<input checked="" type="checkbox"/>											
No. of pieces	DESCRIPTION			MATERIAL	STANDARD	NET.WT.IN KGS.		DRAWING No.		ITEM No.	
	REFERENCE:			ALTERATIONS:		DCN REF	DATE	SIGN.	INDEX		
SCALE 1: 25	DRAWN	V.KRISHNAPRIYA									
	CHECKED	R.RAMAMOORTHY									
	APPROVED	C.S.JAYASHEELAN									
	DATE	20-08-2008									
MACHINE: ROD HEATING FURNACE				TYPE: ELHEAT 450KW							
		TITLE: <b>TOP BRICK</b> ROD HEATING FURNACE				DRAWING No:				REV.	
						4M18A0328227					
						Sheet No:				No. of Sheets:	

CAUTION: THIS DRAWING IS OUR SOLE PROPERTY AND SHOULD NOT BE USED IN ANY FORM FOR ANY PURPOSE WITHOUT THE WRITTEN PERMISSION OF BHARAT HEAVY ELECTRICALS LIMITED TRICHIRAPPALLI - 620 014.

ALL DIMENSIONS ARE IN MM

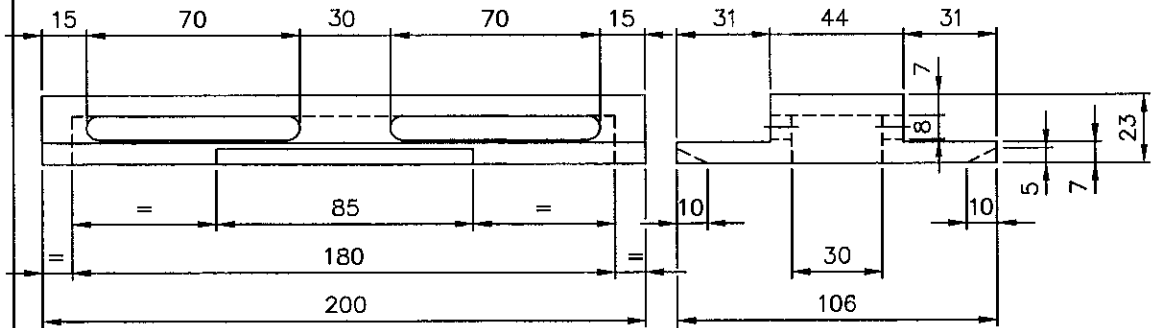
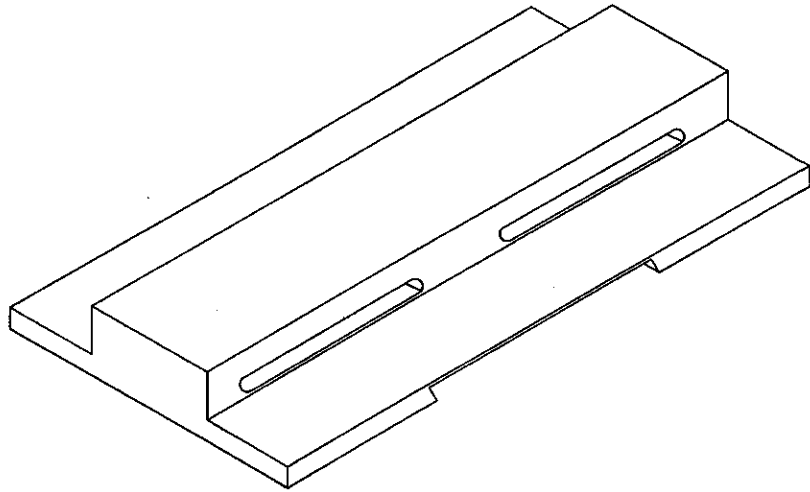

MATERIAL SPECIFICATION: - \* SILLIMANITE (HIGH ALUMINA)  
 $Al_2O_3 = 60\%$   
 PCE = 36 (ORTON CONE)  
 AP = 20%  
 CGS = 400 Kg/Cm<sup>2</sup> (MIN)  
 BD = 2.35 gm/Cm<sup>3</sup>

FOR BOTTOM BRICK REF.DRG.No: - 3.M.18A04.12074

No. of Pieces		DESCRIPTION		MATERIAL	STANDARD	NET.WT.IN KGS.	DRAWING No.		ITEM No.
REFERENCE:		ALTERATIONS:		DCN REF	DATE	SIGN.	INDEX		
SCALE	DRAWN/TCD	R. Narayanan		DRG. MODIFIED TO DATE		15.03.12	CSJ	01	
1:2	CHECKED	R.RAMAMOORTHY							
	APPROVED	C.S.JAYASHEELAN							
	DATE	13.02.03/13.05.11							
MACHINE ELE. SINGLE CHAMBER				TYPE: BHEL/75 KW.					
TITLE:				DRAWING No:		REV.			
COVER				4M18A0427033		01			
(FOR REFRACTORY BOTTOM BRICK)				Sheet No:		No. of Sheets:			

CAUTION: THIS DRAWING IS OUR SOLE PROPERTY AND SHOULD NOT BE USED IN ANY FORM FOR ANY PURPOSE WITHOUT THE WRITTEN PERMISSION OF BHARAT HEAVY ELECTRICALS LIMITED

ALL DIMENSIONS ARE IN MM

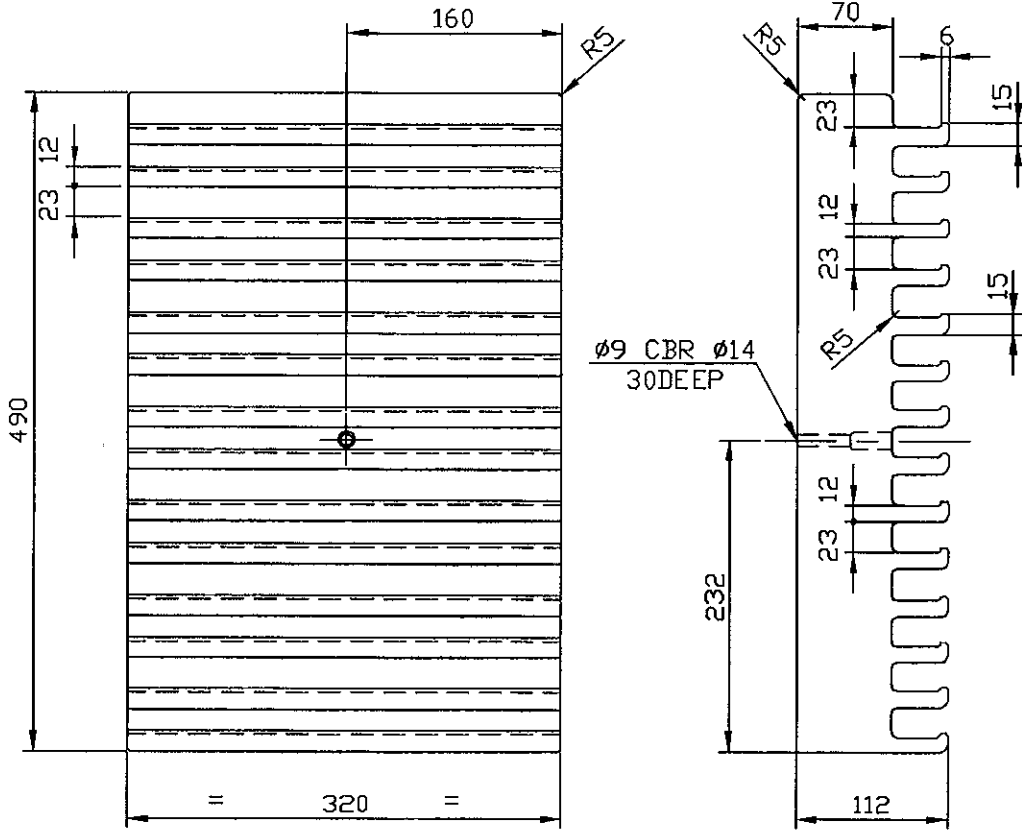

NOTE:

MATERIAL: SILLIMANITE WITH FOLLOWING SPECIFICATIONS.

- Al<sub>2</sub> O<sub>3</sub> - 61%
- Si O<sub>2</sub> - 36.5%
- Fe<sub>2</sub> O<sub>3</sub> - 1.5%
- Ap - 20%
- CCS - 400kg/cm (MIN)%
- PCE - 36 (ORTON CONE)

No. of Pieces		DESCRIPTION	MATERIAL	STANDARD	NET.WT.IN KGS.	DRAWING No.	ITEM No.
REFERENCE:		ALTERATIONS:		DCN REF	DATE	SIGN.	INDEX
SCALE 1 : 5	DRAWN	K.MANIKANDAN					
	CHECKED	R.RAMAMOORTHY					
	APPROVED	C.S.JAYASHEELAN					
	DATE	10.03.06					
MACHINE: ELE SINGLE CHAMFER				TYPE: BHEL 75KW			
TITLE: <b>SIDE FIRE BRICK</b>				DRAWING No:		REV.	
				4M18A0427813			
				Sheet No:		No. of Sheets:	

CAUTION: THIS DRAWING IS OUR SOLE PROPERTY AND SHOULD NOT BE USED IN ANY FORM FOR ANY PURPOSE WITHOUT THE WRITTEN PERMISSION OF DHARAT HEAVY ELECTRICALS LIMITED TRICHIRAPPALLI - 620 014.

ALL DIMENSIONS ARE IN MM

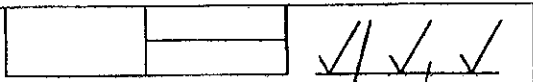
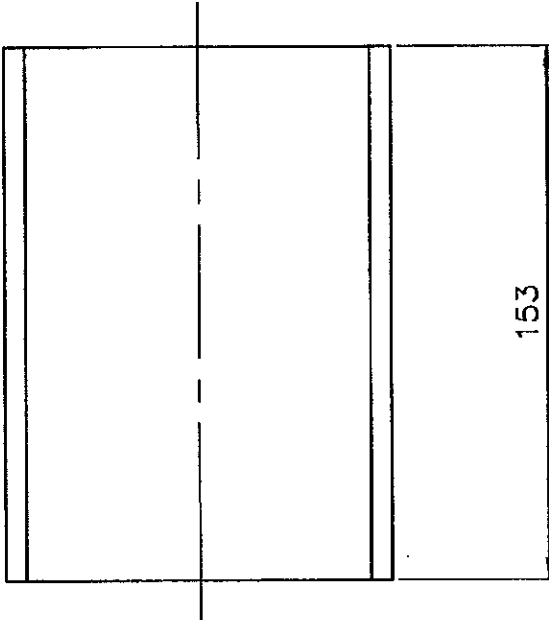
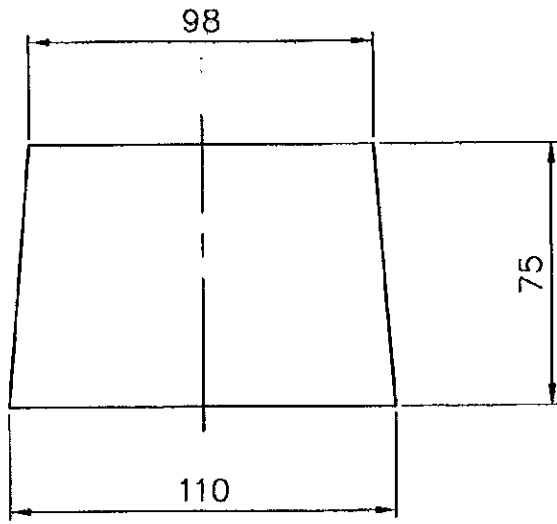

NOTE: - \*

SLICON CARBIDE : 90% MIN.  
 CGS : 600kg/cm<sup>2</sup> MIN.  
 (COLD COMPRESIVE STRENGTH)  
 ΔP : 10% MAX.  
 OPERATING TEMP : 1500° C

No. of Pieces		DESCRIPTION		MATERIAL	STANDARD	NET.WT.IN KGS.	DRAWING No.		ITEM No.
REFERENCE:						COMPONENT CODE: 00		EQUIPMENT CODE: 04	
SCALE		DRAWN	M.k.v.	ALTERATIONS:		DCN REF	DATE	SIGN.	INDEX
1:2		CHECKED							
		APPROVED							
		DATE	28-2-2002						
MACHINE: ELE SINGLE CHAMFER					TYPE: BHEL/75KV				
TITLE: ARCH REFRACTORY BRICK					DRAWING No: 04				REV.
					4-M-18A-26866				
					No. of Sheets:		Sheet No:		







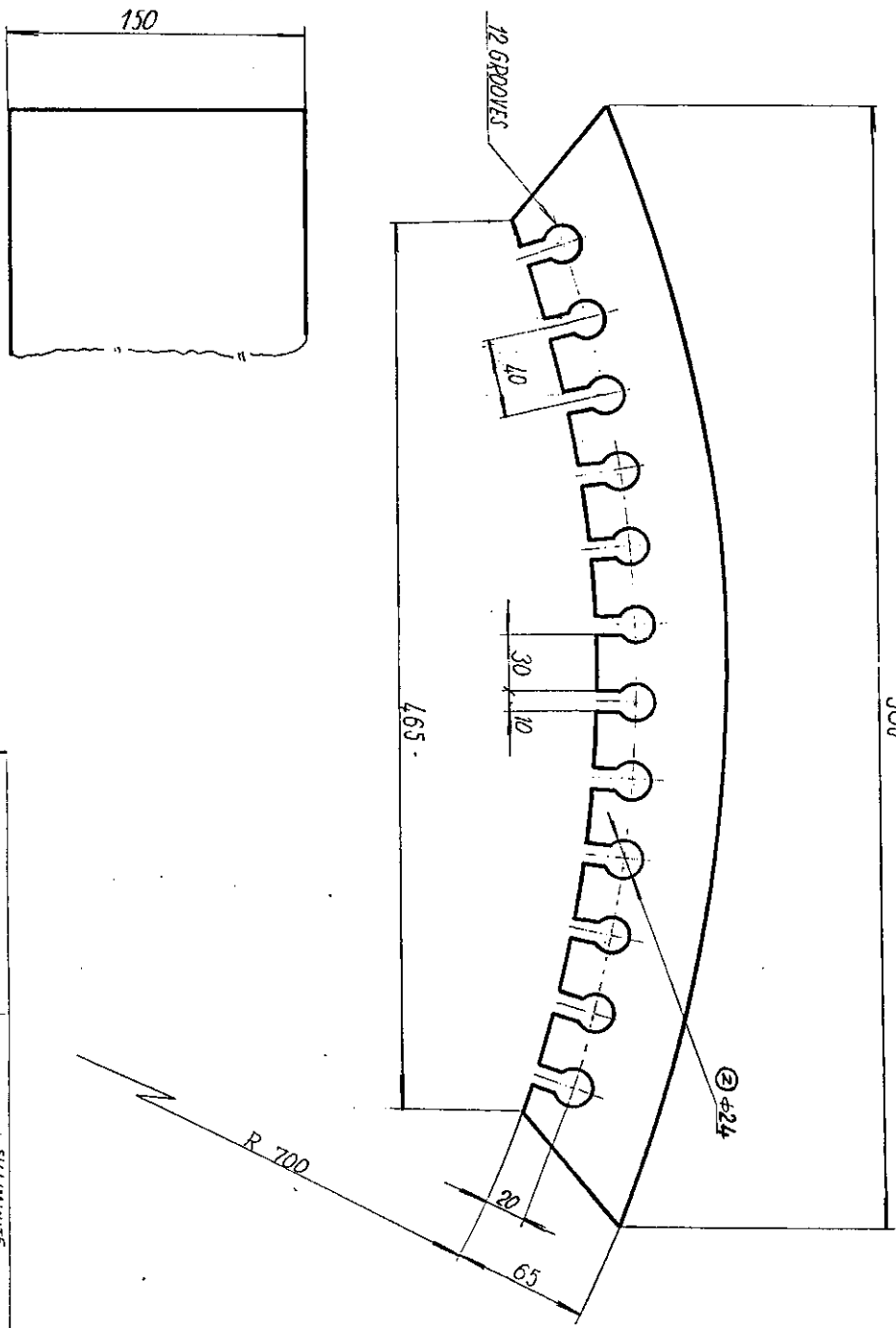

585

4 TOP ARCH FIRE BRICKS		SILLIMANITE	
QTY	NAME - DIMENSIONS	SEMI-PRODUCT	FINAL MATERIAL
144	18.5 x 22.5 x 4.5	18.5 x 22.5 x 4.5	18.5 x 22.5 x 4.5
SCALE	DRAWN BY	CHECKED BY	APPROVED BY
2:5	T. N. KENNEDY	[Signature]	[Signature]
DATE	2-8-66	TRANSPARENT	COPY No.
NAME: TOP ARCH FIRE BRICKS		TYPE: METCO - 18KV-100	
3-M-18a-0171		13	

SCANNED

2-M-18a-0034

**CAUTION:** THIS DRAWING IS OUR SOLE PROPERTY AND SHOULD NOT BE USED IN ANY FORM FOR ANY PURPOSE WITHOUT THE WRITTEN PERMISSION OF DHARAT HEAVY ELECTRICALS LIMITED TRICHIRAPPALLI - 620 014.

ALL DIMENSIONS ARE IN MM

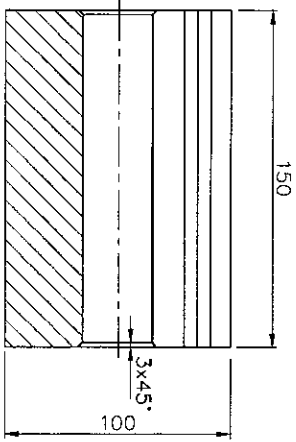
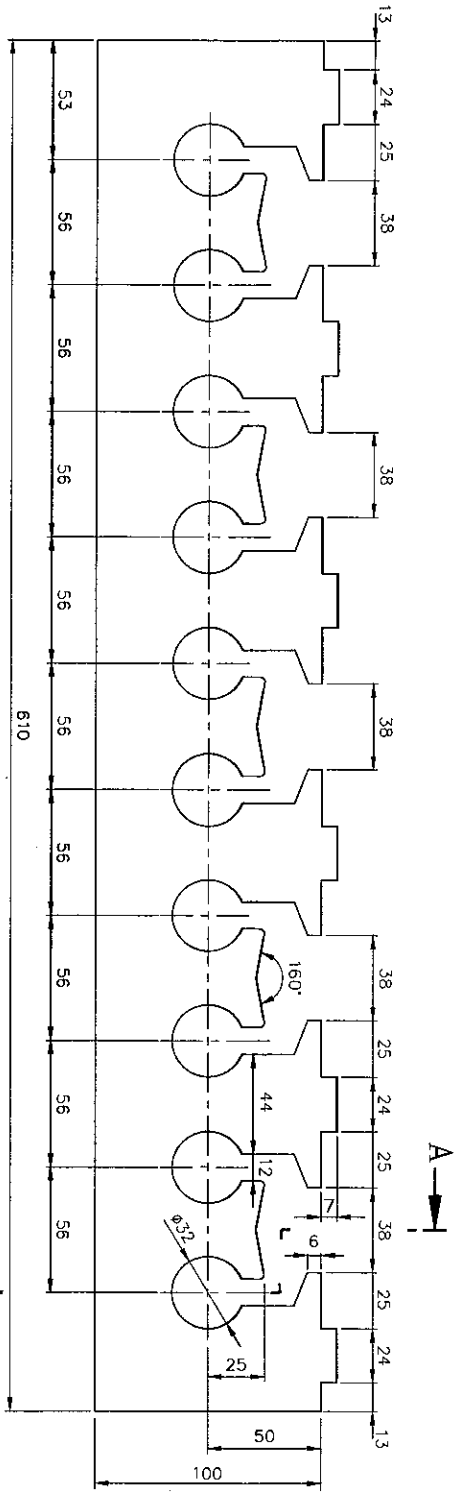

**SEC-AA**

PHYSICAL PROPERTIES		CHEMICAL PROPERTIES	
MAX. TEMPERATURE :	1200°C	Al <sub>2</sub> O <sub>3</sub> :	50 TO 80%
C.C.S :	350 kg/cm <sup>2</sup>	Fe <sub>2</sub> O <sub>3</sub> :	2 %
APPARENT POROSITY :	24 TO 29%	P.L.C.E :	+ 36

**NOTE FOR SUPPLIERS :**

- 01. DOLL HOLES IN ALL BRICKS SHOULD BE ALIGNED FOR STRAIGHTNESS SO THAT A SINGLE COIL COULD BE INSERTED THROUGHOUT

	No. of Sheets 1	DESCRIPTION REFERENCE	SILICANITE OR KYANITE	IS: 2044	NET WT IN KGS	DRAWING No. 3M18A10513827	ITEM No.
	SCALE 1:2	CHECKED R.RAMAMOORTHY	STANDARD ALTERATIONS	DATE 23-02-11	MACHINE ELE. SINGLE CHAMBER	TYPE METCO-45KW	REV.
TITLE <b>BOTTOM FIRE BRICK</b>		APPROVED C.S. JAYASHELAN	G.G.R	R.RAMAMOORTHY	DATE 23-02-11	SIGN.	INDEX

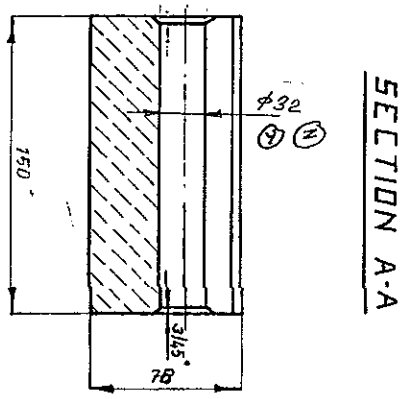
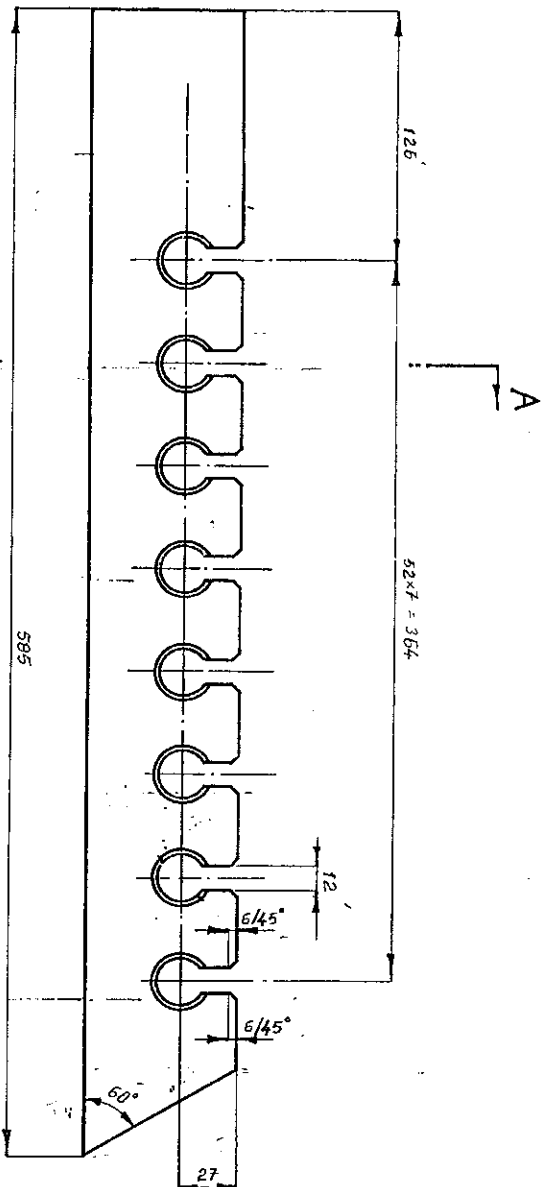

NOTE FOR SUPPLIERS:

1. COIL HOLES IN ALL BRICKS SHOULD BE ALIGNED FOR STRAIGHTNESS SO THAT A SINGLE COIL COULD BE INSERTED THROUGHOUT.

PHYSICAL PROPERTIES

MAX. TEMPERATURE : 1200 °C  
 P. O. S. : 350 kg/cm<sup>2</sup>  
 APPARENT POROSITY : 24 TO 29 %

CHEMICAL PROPERTIES

AL<sub>2</sub>O<sub>3</sub> : 57 TO 60 %  
 Fe<sub>2</sub>O<sub>3</sub> : 2 %  
 P. O. E : + 36

8x8	DESCRIPTION	SEMI PRODUCT	FINAL MATERIAL	REFERENCE	TOTAL NET WT (KG)	NET WT	NET GROSS WT	DRAWING NO.	ITEM NO.
			SILUMINITE-15:2044 OR KUNWITE		24380	1591055			
NO. OF PROJECTS	REMARKS	SCALE	DRAWN	CHECKED	APPROVED	DATE	DATE	DATE	DATE
25						15-7-1967			
MACHINE: ELECTRIC SINGLE CHAMBER FURNACE									
TITLE: SIDE FIREBRICK									
DRAWING NO: 3-M-18A-0587									
NO. OF SHEETS: 05									
SHEET NO: 05									



CAUTION: THIS DRAWING IS OUR SOLE PROPERTY AND SHOULD NOT BE USED IN ANY FORM FOR ANY PURPOSE WITHOUT THE WRITTEN PERMISSION OF BHARAT HEAVY ELECTRICALS LIMITED TRICHIRAPPALLI - 620 014.

ALL DIMENSIONS ARE IN MM

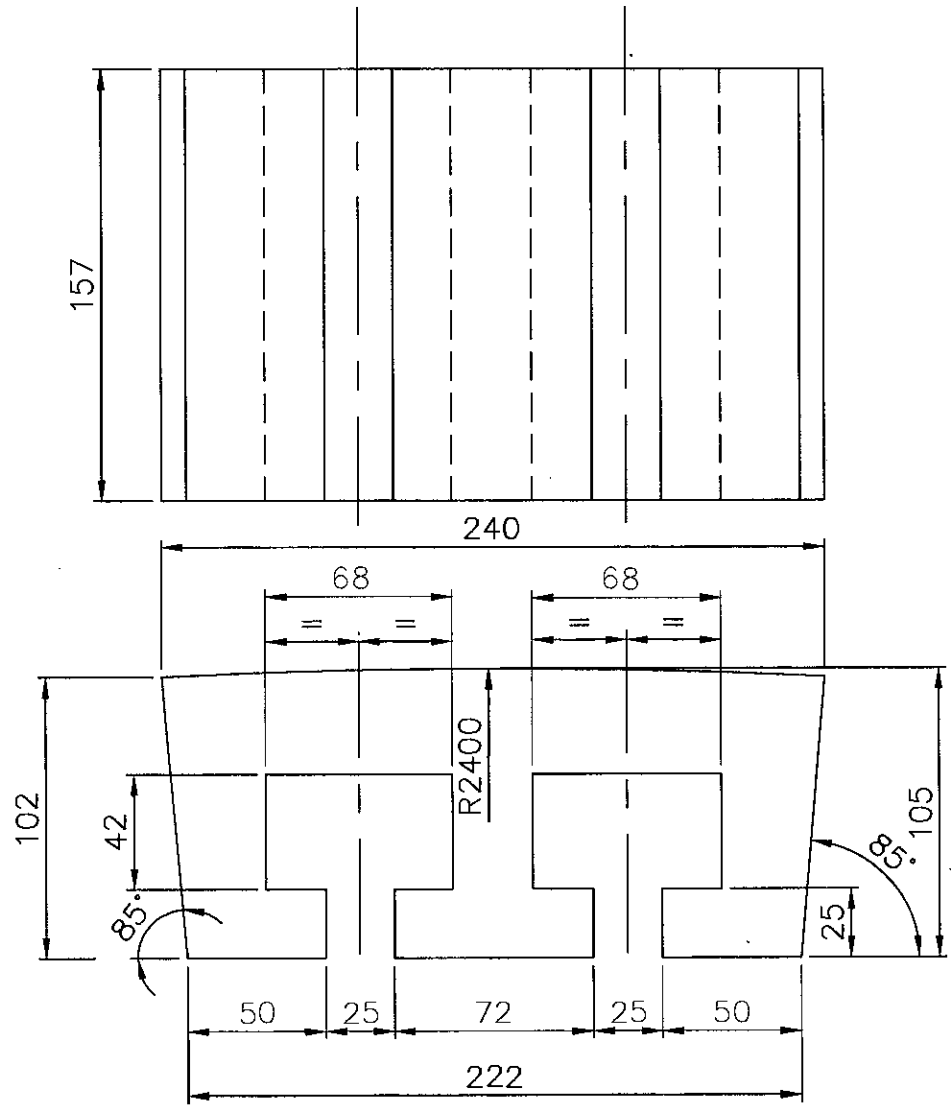

**CHEMICAL COMPOSITION**

Al<sub>2</sub>O<sub>3</sub> : 56-60%, Fe<sub>2</sub>O<sub>3</sub> : 1% PCE : +35  
 CCS : 350 kgf/cm<sup>2</sup>, App.Porosity : 24 to 29% ,  
 Bulk density : 2.3 to 2.5 gm/cc.

No. of Pieces		DESCRIPTION	MATERIAL	STANDARD	NET.WT.IN KGS.	DRAWING No.	ITEM No.
No. of Pieces		REFERENCE:	ALTERATIONS:		DCN REF	DATE	SIGN.
SCALE 1:2.5	DRAWN	T.T.Balakrishnan					
	CHECKED	R.Ramamoorthy					
	APPROVED	C.S.Jayasheelan					
	DATE	10.11.09					
MACHINE: ELE.SINGLE CHAMBER				TYPE: ELECTRO THERME-60KW			
TITLE: <b>ARCH BRICK</b>				DRAWING No:		REV.	
				4M18A1828436			
				Sheet No:		No.of Sheets:	

39-607 A

**Caution**  
 THIS DRAWING IS OUR SOLE PROPERTY AND SHOULD NOT BE USED IN ANY FORM FOR ANY OTHER PURPOSE WITHOUT THE WRITTEN PERMISSION OF BHARAT HEAVY ELECTRICALS LTD., TIRUCHIRAPALLI - 620 016.

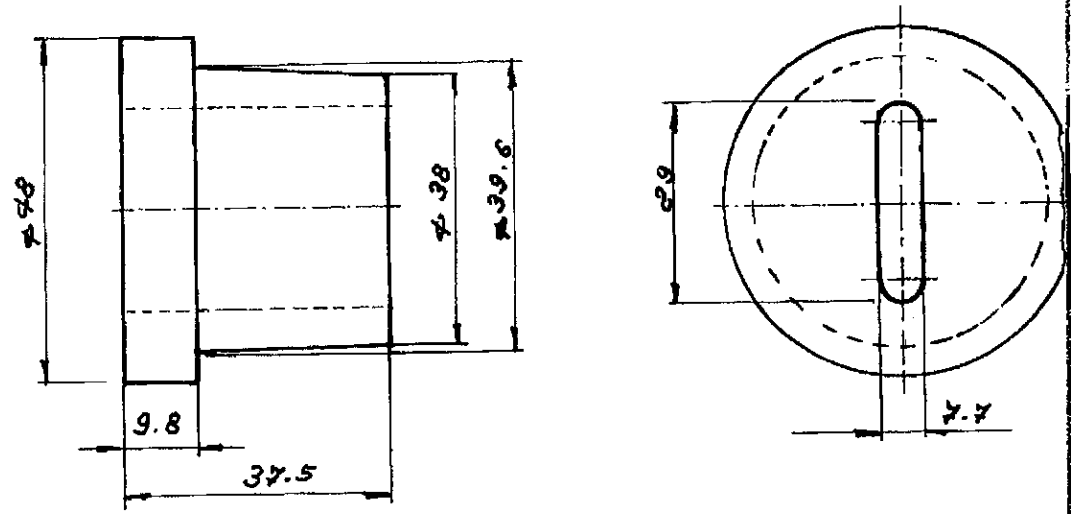

**NOTE:-**

PHYSICAL PROPERTIES.

MAX. TEMPERATURE - 1600°C  
 CCS - 350 kg/cm<sup>2</sup>  
 APPARENT - 24% TO 29%

CHEMICAL COMPOSITION

Al<sub>2</sub>O<sub>3</sub> - 57% TO 60%  
 Fe<sub>2</sub>O<sub>3</sub> - 2% MAX  
 PCE - +36

		SILLIMITE(OR) MULLITE(OR) KYANITE		IS:2044					
No. of PCS.	DESCRIPTION	MATERIAL	STD/BPS	Net wt. (kg)	Gross wt. (kg)	DRAWING No.		Item No.	
REFERENCE:			ALTERATIONS	EC: 22	CC: 17	DCN	DATE	SIGN.	Index
SCALE 1:1	DRAWN								
	CHECKED								
	APPROVED								
	DATE	08-08-97							
MACHINE: PIT TYPE HIGH TEMP.				TYPE: THE RELCA 120 KW			Total wt. (kg.)		
TITLE				DRAWING No.			REV.		
				<b>CERAMIC BUSH</b>			22		
( HEATING ELEMENT TERMINAL )				4-M-18A-26024					
				No. of Sheets :			Sheet No.		

**Caution**

THIS DRAWING IS OUR SOLE PROPERTY AND SHOULD NOT BE USED IN ANY FORM FOR ANY OTHER PURPOSE WITHOUT THE WRITTEN PERMISSION OF BHARAT HEAVY ELECTRICALS LTD., TIRUCHIRAPALLI - 620 014.

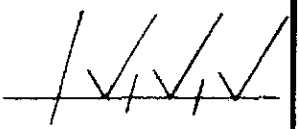

**ALL DIMENSIONS ARE IN MM**

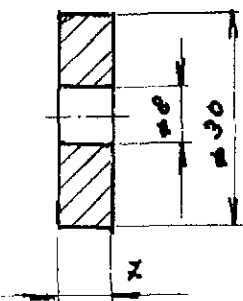

**CHEMICAL COMPOSITION :-**

- AL<sub>2</sub>O<sub>3</sub> - 56-60 %
- FE<sub>2</sub>O<sub>3</sub> - 1%
- P.C.E 436
- C.C.S - 350 kgf/cm<sup>2</sup>
- APPARENT POROSITY 24-29%
- BULK DENSITY - 2.3-2.5 gm/cc

AVOID SHARP CORNERS

		SILLIMINATE 15:2044							
No. of p/s.	DESCRIPTION	MATERIAL	STD/BPS	Net wt. (kg)	Gross wt. (kg)	DRAWING No.	Item No.		
REFERENCE:			AI TERTATIONS	CC:	EG 22	DATE	SIGN.	Index	
SCALE 1:1	DRAWN	<i>[Signature]</i>							
	CHECKED	<i>P. Ramamurthy</i>							
	APPROVED	<i>[Signature]</i>							
	DATE	17-06-98							
MACHINE PIT TYPE HIGH TEMP		TYPE: THERMICK 120 KW		Total wt. (kg.)					
FILE		DRAWING		22		REV.			
<b>CERAMIC WASHER</b>		<b>4-M-18A-26218</b>							
(12φ8 00φ30-7t)									
		No. of Sheets :		Sheet No.					



CAUTION: THIS DRAWING IS OUR SOLE PROPERTY AND NOT BE USED IN ANY FORM FOR ANY PURPOSE WITHOUT THE WRITTEN PERMISSION OF BHARAT HEAVY ELECTRICALS LIMITED TRICHIRAPPALLI - 620 014.

ALL DIMENSIONS ARE IN MM

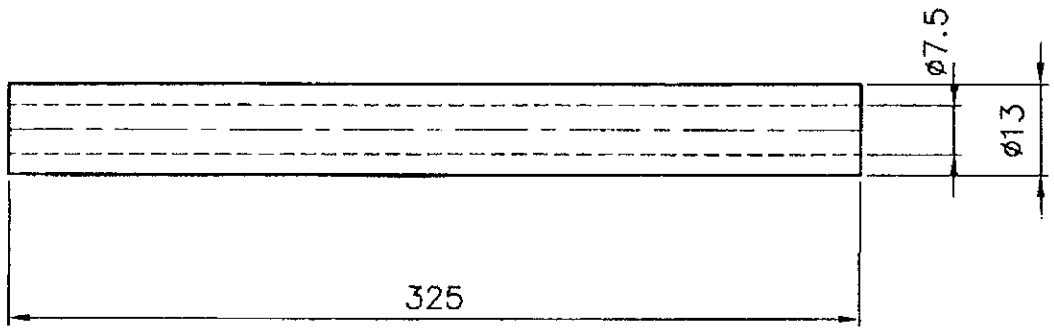
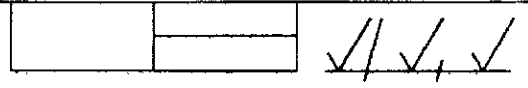

CHEMICAL COMPOSITION

Al<sub>2</sub>O<sub>3</sub> - 56-60%

Fe<sub>2</sub>O<sub>3</sub> - 1%

P.C.E +36

APPARENT POROSITY - 24 TO 29%

BULK DENSITY - 2.3-2.5 gm/cc

No. of Pieces		DESCRIPTION	MATERIAL	STANDARD	NET.WT.IN KGS.	DRAWING No.	ITEM No.
REFERENCE:				COMPONENT CODE: 00	EQUIPMENT CODE: 22		
SCALE	DRAWN	ALTERATIONS:					
1:1	CHECKED	m.kumaravel		DCN REF	DATE	SIGN.	INDEX
	APPROVED	<i>R. Ramamathy</i>					
	DATE	17-6-98					
MACHINE: PIT TYPE HIGH TEMP		TYPE: THERILEK-120kw		DRAWING No: 22		REV.	
TITLE: CERAMIC TUBE		4-M-18A-26219		No. of Sheets		Sheet No	

INDEX No. 39 - 607

**CAUTION**

THIS DRAWING IS OUR SOLE PROPERTY AND SHOULD NOT BE USED IN ANY FORM FOR ANY OTHER PURPOSE WITHOUT THE WRITTEN PERMISSION OF  
**BHARAT HEAVY ELECTRICALS LTD.,**  
 TIRUCHIRAPALLI-14

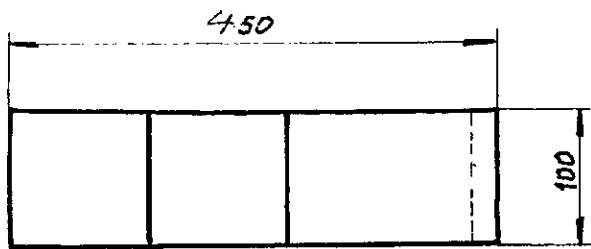
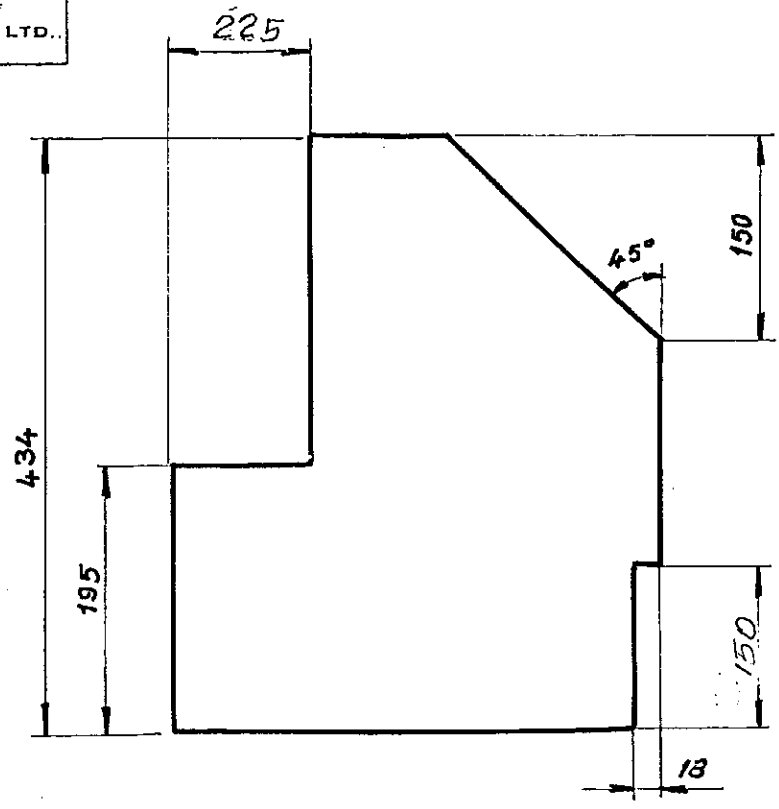

PART NO.	FURNACE	MATL.	REQD. QTY.	UNIT WT. KGS.	TOTAL WT. IN KGS.
B-1	PR	15.8	323	23.00	7429.00
	SR	15.8	666	23.00	15318.00

NO. OF PIECES		DESCRIPTION		SEMI-PRODUCT	FINAL MATERIAL	INITIAL MATERIAL	SCRAP SORT	NET WT (kg)	GROSS WT (kg)	1-M-18d. 1586 B-1	
REMARKS										TOTAL NET WT (kg)	
SCALE <b>1:5</b>	DRAWN	<i>[Signature]</i>			REFERENCE	ALTERATIONS			DATE	SIGNATURE	INDEX
	CHECKED	<i>[Signature]</i>			DRG. No.	DIMENSION 150 Wx 117					
	APPROVED	<i>[Signature]</i>			3002/C/502-2	DIMENSION 225 Wx 100					
	SYDS. OFFICER					Dim 450 Wx 350					
DATE		04-07-85									
MACHINE PLATE HEATING FURNACE					TYPE: VULCAN 150 T.		INV. NO.				
TITLE: <b>SHAPED BRICK</b>					DRAWING NO.		07				
					<b>4-M-18d-22244</b>						
					NO. OF SHEETS		SHEET NO.				

CAUTION: THIS DRAWING IS OUR SOLE PROPERTY AND SHOULD NOT BE USED IN ANY FORM FOR ANY PURPOSE WITHOUT THE WRITTEN PERMISSION OF BHARAT HEAVY ELECTRICALS, LIMITED TRICHIRAPPALLI - 620 014.

ALL DIMENSIONS ARE IN MM

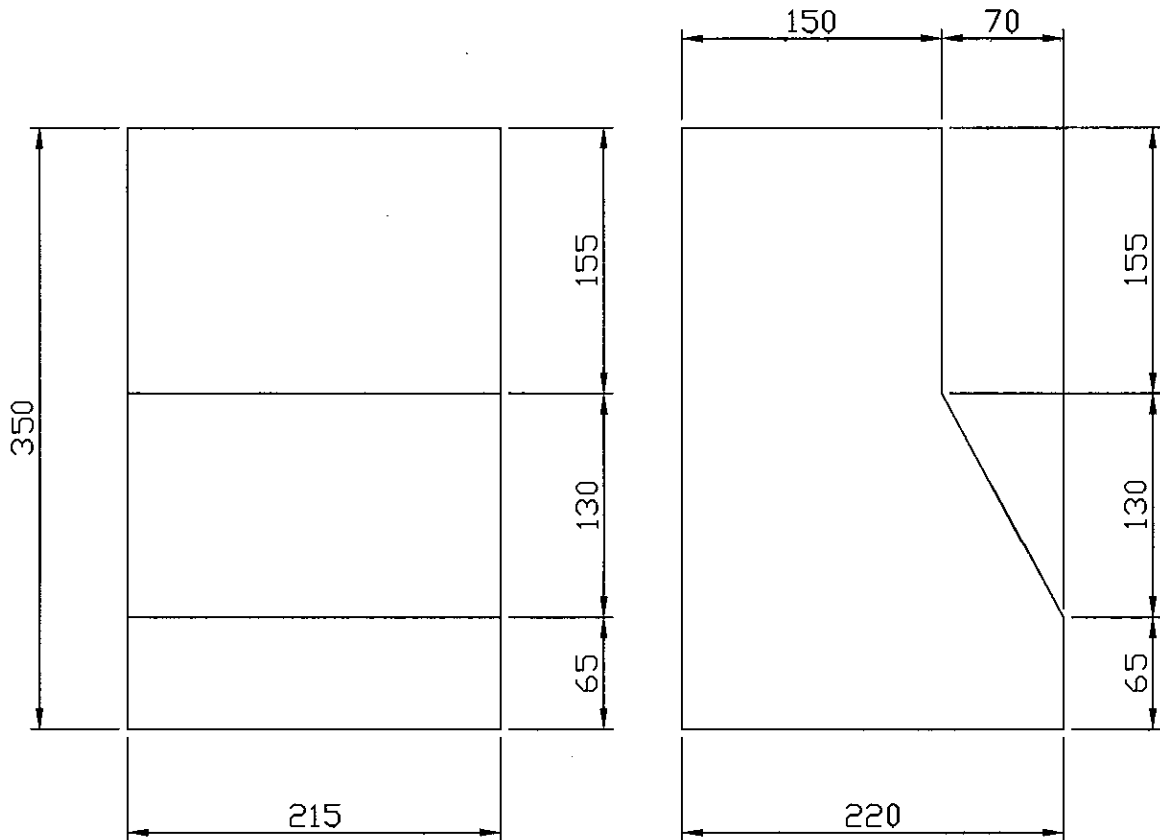

CHEMICAL COMPOSITION  
 $Al_2O_3$  : 56-60%  
 $Fe_2O_3$  1% PCE+35  
 CCS: 350kgf/cm<sup>2</sup>  
 APP. POROSITY 24 to 29%  
 BULK DENSITY 2.3 to 2.5gm/CC

		SILIMINITE	IS: 2044			
No. of Pieces	DESCRIPTION	MATERIAL	STANDARD	NET.WT.IN KGS.	DRAWING No.	ITEM No.
	REFERENCE:		ALTERATIONS:	DCN REF	DATE	SIGN.
SCALE	DRAWN	T.T.Balakrishnan				
1: 2.5	CHECKED	R.Ramamoorthy				
	APPROVED	C.S.Jayasheelan				
	DATE	21.05.2011				
MACHINE: CAR BOTTOM FURNACE			TYPE: PRECON LPG-40T			
TITLE: BOGIE SIDE BRICK THERMO PRESS SHOP			DRAWING No: 4M18D1028949			REV.
			Sheet No:			No. of Sheets:

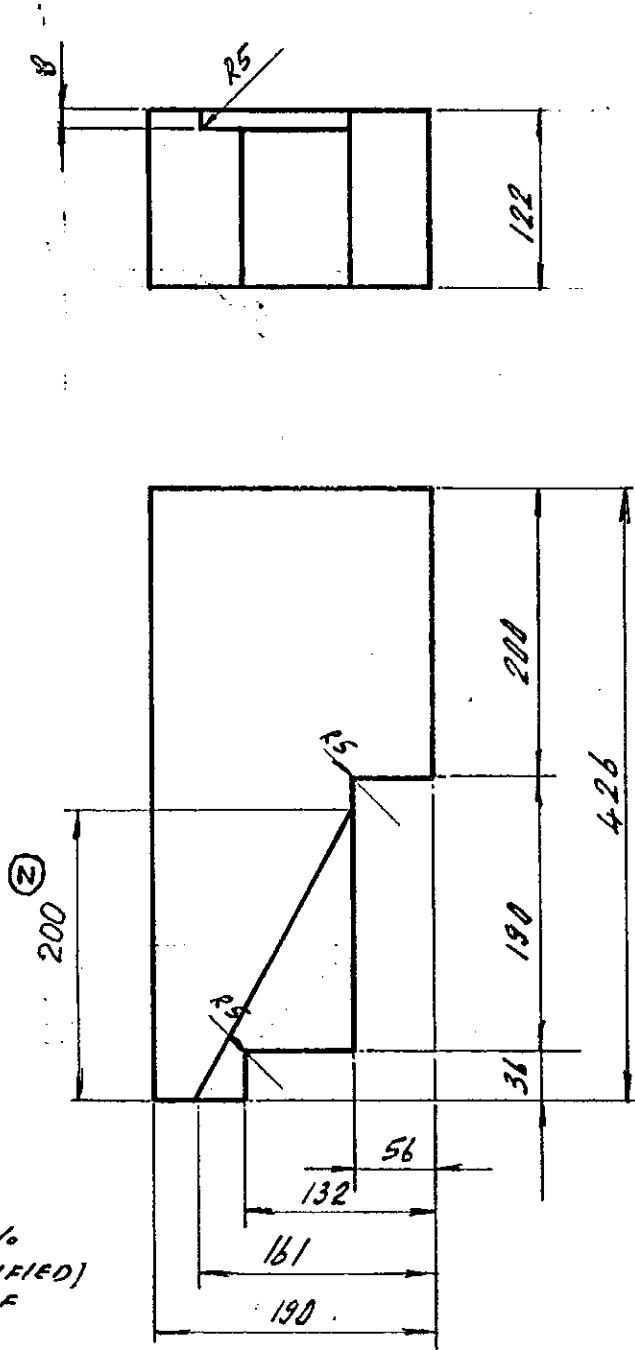

NOTE:  
 ALLOWANCE OF  
 DIMENSIONS  $\pm 2\%$   
 ALL EDGES (UNSPECIFIED)  
 TO BE ROUNDED OFF  
 BY 3 m.m.

450 (100T), 194 (50T)			15.8					1-M-18d-0167 1-M-18d-0198	9	
NO. OF PIECES	NAME	DIMENSIONS	SEMI-PRODUCT	FINAL MTL.	INITIAL MTL.	SCRAP SDT	NET WT.	GROSS WT.	DRAWING No.	ITEM No.
REMARKS					TOTAL NET WT. 26.					
1:5	SCALE	1:5	DRAWN BY	M. A. M. A. M.	REFERENCE	ALTRADIANS	DATE	SIGN.	INDEX	
	CHECKED BY		APPROVED BY		No. 2269	WAS - 105	25/2/69		(2)	
	STDS. OFFICER		DATE	18.10.1966	PART No. 1					
					F-42270					
M/C CAR BOTTOM FURNACE					TYPE		100TONS./50T. INV. NO.		LOC:	
NAME:					CAR SIDE BRICK					
BHE					L-M-18d-0626					

**BHARAT HEAVY ELECTRICALS LIMITED TIRUCHIRAPALLI**  
**CAPITAL PURCHASE**

Annexure-A

**PART - I**

**ACCEPTANCE OF COMMERCIAL TERMS AND CONDITIONS BY THE VENDORS.**

(This should be essentially filled in and sent along with the techno-commercial offer without fail. If this check list is not filled and submitted along with techno-commercial offer (Part I) or if the vendor does not confirm acceptance to the terms and conditions proposed herein, BHEL reserves the right to reject such offers)

**CHECK-LIST FOR INDIGENOUS VENDORS**

**DESCRIPTION**

The Bidders shall submit their offer in **TWO INNER ENVELOPES** as indicated below which shall be sealed in one outer envelope.

- ❖ **Envelope I:** This sealed envelope should contain all the copies of technical bid together with un-priced commercial bid. This envelope should be clearly marked "**Part I - Technical and commercial bid**", indicating Enquiry No., Due Date and Address & Reference of the Bidder.
- ❖ **Envelope II:** This sealed envelope should contain **price details**. This envelope should be clearly marked "**Part II - Price bid**", indicating Enquiry No., Due Date and Address & Reference of the Bidder. This part should contain the schedule of price particulars and must be co-related to the technical details provided in Part I.

All the two envelopes (Part I&II) shall be put in one cover, duly sealed, super scribing as "**Part I and Part II of Enquiry No., due date of opening**" and the address and reference of the Bidder. The offer received without the above guidelines, will not be considered for opening.

The above offer should reach this office on or before the due date by 14.00 Hrs (IST). Late offers will not be considered.

Tender should not be addressed to any Individual's name but only by designation to:

1) Please submit your offer on F.O.R - BHEL, TRICHY (Tamilnadu) basis and in two part (part-i: techno-commercial bid and part-ii: price bid) in a separate covers and both covers to be placed in an envelope which is super scribed with enquiry no, enquiry date and due date of tender opening.

2) If the offer is submitted in single part and the same will be liable for rejection.

3) All the Tenders may be addressed to the following address to

**The Tender Opening Cell/MM  
Room No-26, Building – 24, Ground Floor  
Bharat Heavy Electrical Limited  
Tiruchirappalli- 620014.,  
TAMILNADU, INDIA**

4) In case personal delivery of the offer, it shall be dropped into the respective box after duly entering the data in the system kept in room no. 26.

5) Offers will be accepted received till 14.00 hrs on the due date. Therefore Vendors shall ensure to submit the offers before this time.

6) Vendors are requested to avoid submission of offers thro email / fax. In case of any unavoidable situation, offers shall be sent thro email to the following mail ID only "**tender\_cell@bheltry.co.in**"

Tenders should be free from **CORRECTIONS AND ERASURES**. Corrections if any, must be attested. All amounts shall be indicated both in words as well as in figures. In case of any difference between amount quoted in words and figures, amount quoted in words shall prevail.

Offers should be in **ENGLISH** and accompanied by detailed technical literature, catalogue and detailed dimensional drawings in **ENGLISH** or otherwise, the offers will not be considered.

**OPENING OF TENDERS**

The Part I- Technical & commercial bid would be opened on the Tender opening date.

Part-II, Price bid of technically suitable Bidders alone would be opened after complete evaluation of Part-I. Hence the Bidders are required to submit their best competitive price in the price bid in a sealed cover (Part-II).

Date and time of Price Bid (Part-II) opening date shall be intimated to the technically and commercially acceptable bidders only. Clarifications if any required by BHEL for Technical evaluation would be sought from bidders before opening of Part II - Price Bid

**TAXES AND DUTIES :**

All Taxes and Duties payable as extra to the quoted price should be specifically stated in offers along with CST & TIN No / Tariff No. etc., failing which the purchaser will not be liable for payment of such Taxes and Duties. Our TIN No. 33243560005, TNGST No. 3560005, CST. No. 239383 Dt. 11-06-1991 & BHEL ECC No. AAACB4146PXM012, Service Tax Reg No (STC)- AAACB4146PST006. Assessment circle Tiruverambur.

**Cenvat credit & VAT credit** (for Indian Bidders only): If any Excise Duty is payable, the chapter head / sub-head reference and the rate of the duty should be quoted. If the tenderer is availing **CENVAT** credit for his input materials, the effect of Proforma credit should be passed on to the purchaser

**Income Tax applicable**

Any service charges payable towards supervision of E&C, training, performance prove-out etc., will be released after deduction of Income Tax as per Indian Income Tax Act / as per the Govt. of India rules and TDS certificate will be issued by BHEL for such deductions. Applicable service tax on E&C charges will be payable extra. The liability of depositing the same to the Govt. will be of the supplier

SL. NO.	<b><u>BHEL COMMERCIAL TERMS AND CONDITIONS FOR INDIGENOUS SUPPLIES</u></b>	Vendor's Confirmation / Comments
1	<p><b><u>Bid should be submitted in Two Parts.</u></b></p> <p>1. Techno-commercial Bid (Part-I) and 2. Price Bid (Part-II) in a separate sealed cover and both the covers must be placed in a Third Cover and Sealed. Our Enquiry No., Enq. Date &amp; Enq. Due date must be written on all Three covers</p>	
2	<p><b><u>ARBITRATION:</u></b> All disputes or differences whatsoever which may arise at any time during execution of the Contract shall be mutually settled by BHEL and Contractor as per provision of the Contract. However, in the event such disputes cannot be settled mutually, such disputes shall be settled as per the Arbitration and reconciliation Act, 1996 of the Govt. of India and it's subsequent amendments. In case of disputes with the Central PSUs, the same shall be settled at Tiruchirappalli as per the Guidelines of the Govt. of India.</p> <p>However, during the period such disputes are settled either by mutual discussions between the parties or by legal means, Contractor shall continue to do the work as per terms &amp; conditions of Contract.</p>	
3	<p>If offer is received from both OEM/Manufacturer and authorized dealers or Agent, then OEM/Manufacturer offer will only be considered and dealers or Agent offer will be ignored.</p>	
4	<p>Technical confirmation to BHEL's Specification shall be furnished. If needed additional sheets shall be used.</p>	
5	<p>Prices shall be quoted item wise only.</p>	
6	<p>Delivery INCO TERMS- Price quoted <b>-FOR BHEL TRICHY (TN), STORES</b> or ex-WORKS Basis or, <b>FOR WORKS (DESPATCHING STATION)</b> In case of EX works / FOR WORKS basis, indicate the Despatching station.</p> <p>Prices shall be quoted on "FIRM PRICE" basis only.</p>	

7	<p><b>Validity</b> of offer shall be for a minimum period of <b>120 days</b> from the date of Tender opening</p>	
8	<p><b>Delivery period</b> from the date of Letter of Intent / Purchase order (write in <b>DAYS / WEEKS</b>)</p>	
9	<p><b>Liquidated damages</b> shall be 0.5% of the total order value per week or part thereof subject to a maximum of 10% of the total order value.</p> <p>For staggered delivery schedule, LD shall be 0.5% of the undelivered portion per week of the delay or part thereof subject to a maximum of 10% of the total order value.</p> <p><b>** In case of single delivery date , Order should be completed 100% for processing the bill, otherwise LD will be calculated based on Total PO Value restricted to Max % as mentioned in the PO Condition column.</b></p> <p><b>Material Despatched after Due date:</b> Once the delivery due date is crossed, <u>bills have to be clubbed till final despatch and forwarded for processing of payment as a single bunch.</u> LD percentage will be calculated from Delivery due date to final despatch date.</p> <p>For staggered delivery schedule, LD shall be 0.5% of the undelivered portion per week of the delay or part thereof subject to a maximum of 10% of the total order value.</p> <p><b>Any deviation from the above LD clause, loading will be applied to the extent to which it is not agreed by the bidder (at offered value).</b></p>	
10	<p><b><u>Payment term for supply portion:</u></b></p> <p>Payment term is <b>100% direct payment after 45 days</b> from the date of receipt and acceptance of materials.                  Note: Only Direct Payment after goods receipt &amp; acceptance will be accepted .Above payment term acceptance is essential for consideration of your offer</p> <p><b>Any deviation in the above payment term will attract loading as mentioned below. "Base rate of SBI (as applicable on the date of bid opening. Techno-commercial bid opening in case of two part bids) + 6% shall be considered for loading for the period of relaxation sought by bidders.</b></p> <p>Payment through Bank is not preferred. In case of Payment through Bank is opted by Supplier, BHEL prefers documents submission through bank with copy of LR and door delivery of Goods to Stores with Consignee copy attached. In this case Loading will be 3% on the offered value. Offers of indigenous Suppliers with payment terms as <u>LC/Advance Payment are liable for rejection.</u></p> <p><b><u>Important Note:</u></b> BHEL will consider the ranking after the loading is applied as referred vide Sl. No. 9 &amp;10 above wherever deviations are observed.</p>	

11	<p><b><u>Following Risk Purchase clause shall be applicable:</u></b>                  The purchaser at his option will be entitled to terminate the contract and to purchase elsewhere at the risk and cost of the seller either the whole of the goods or any part which the supplier has failed to deliver or dispatch within the time stipulated or if the same were not available, the best and the nearest available substitute therefore. The supplier shall be liable for any loss which the Purchaser may sustain by reason of such risk purchases.</p>	
12	<p><b><u>Erection / commissioning: (if applicable only)</u></b>                  Erection / commissioning charges if any has been mentioned in the offer or else confirmation that Erection / commissioning shall be done at free of cost is available in the offer.</p>	
13	<p>The equipment shall be guaranteed as per tender condition from the date of receipt &amp; acceptance /(commissioning date ,if applicable as per tender condition). Normally No deviation permitted and the <u>deviated offers are liable for rejection.</u></p>	
14	<p>Equipment will be inspected at vendor's works prior to dispatch if applicable. However final inspection and acceptance of equipment will be after installation at BHEL, Trichy and Tamilnadu.</p>	
15	<p>The vendor shall provide necessary drawings, Test Certificates and Operating Maintenance Manuals etc., as called for in the Technical Specification, in the required number of copies at no extra cost.</p>	
16	<p>Any warranty replacement during warranty period shall be supplied free of charge on FOR BHEL, Trichy, Tamilnadu basis.</p>	

17

**Reverse Auction (RA):**

BHEL reserves the right to conduct on-line internet Reverse Auction ie. **ONLINE BIDDING (THROUGH A SERVICE PROVIDER)** for finalizing the Tender. This decision will be communicated to the technically qualified vendors after technical evaluation. Details / General terms / guidelines for conduct of RA are shown below

Vendors are requested to confirm their acceptance for BHEL proceeding with RA route for finalization of the enquiry.

1. For the proposed reverse auction, technically and commercially acceptable bidders only shall be eligible to participate.
2. BHEL will engage the services of a service provider who will provide all necessary training and assistance before commencement of on line bidding on internet.
3. BHEL will inform the vendor in writing in case of reverse auction, the details of Service Provider to enable them to contact & get trained.
4. Business rules like event date, time, start price, bid decrement, extensions etc. also will be communicated through service provider for compliance.
5. Vendors have to fax the Compliance form in the prescribed format (provided by Service provider) before start of Reverse auction. Without this, the vendor will not be eligible to participate in the event.
6. BHEL will provide the calculation sheet (e.g., EXCEL sheet) which will help to arrive at "Total Cost to BHEL" like Packing & forwarding charges, Taxes and Duties, Freight charges, Insurance, Service Tax for Services and loading factors (for non-compliance to BHEL standard Commercial terms & conditions) for each of the vendor to enable them to fill-in the price and keep it ready for keying in during the Auction
7. Reverse auction will be conducted on scheduled date & time.
8. At the end of Reverse Auction event, the lowest bidder value will be known on the network.
9. The lowest bidder has to Fax/e-mail the duly signed Filled-in prescribed format as provided on case-to-case basis to BHEL through Service provider within 24 hours of Auction without fail.
10. Any variation between the on-line bid value and the signed document will be considered as sabotaging the tender process and will invite disqualification of vendor to conduct business with BHEL as per prevailing procedure.
11. In case BHEL decides not to go for Reverse Auction procedure for this tender enquiry, the Price Bids and price impacts, if any, already submitted and available with BHEL shall be opened as per BHEL's standard practice.
12. BHEL reserves the right to negotiate if need be, with the "L1" vendor of the Reverse Auction
13. **BHEL reserves the right not to consider offers from vendors not complying with the RA process for finalization of the enquiry.**
14. If the Bidder or any of his representatives are found to be involved in Price manipulation/ cartel formation of any kind, directly or indirectly by communicating with other bidders, action as per extant BHEL guidelines, shall be initiated by BHEL and the results of the RA scrapped/ aborted.

In case BHEL decides to go for reverse auction, the H1 bidder(s) (whose quote is highest in online sealed bid) may not be allowed to participate in further RA process.

18

The bidder may also be a Micro and Small Enterprises (MSE) vendor registered as per MSE act. As per the public procurement policy notified by the Central government,

20% of the tendered quantity is earmarked for MSE suppliers in this tender.

Out of the 20% tendered quantity reserved for MSE suppliers, 4% shall be earmarked for procurement from MSE owned by SC / ST entrepreneurs.

In case MSE vendor participating in the tender quotes within the price band of L1 + 15%, they will be allowed to supply the portion of the requirement subject to acceptance of L1 price by MSE vendor. In case of more than one such MSE, the supply shall be shared proportionately.

"MSE suppliers can avail the intended benefits only if they submit along with the offer, attested copies of either EM II certificate having deemed validity (five years from the date of issue of acknowledgement in EM, II) or valid NSIC certificate or EM II certificate along with attested copy of a CA certificate (Format enclosed at Annexure -V where deemed validity of EM II certificate of five years has expired) applicable for the relevant financial year (latest audited). Date to be reckoned for determining the deemed validity will be the date of bid opening (Part 1 in case of two part bid). Non submission of such documents will lead to consideration of their bid at par with other bidders. No benefit shall be applicable for this enquiry if any deficiency in the above required documents are not submitted before price bid opening. **Documents should be notarized or attested by a Gazetted officer for consideration of MSE certificate.**"

Such Micro/Small Enterprises registered vendors must state the sub-category to which they belong and submit documentary proof for the same. The sub-categories:

- (a) Enterprises owned by Scheduled Castes.
- (b) Enterprises owned by Scheduled Tribes.
- (c) Enterprises owned by other than above two categories

The enterprises under (a) & (b) means the proprietor in case of single owned firm and all partners in case of partnership firm and all directors in case of partnership firm and all directors in case of private/public limited must belong to SC/ST category

<b><u>OTHER DETAILS REQUIRED</u></b>		
18	% of Excise Duty with cess (EXTRA / INCLUSIVE / NIL)	
19	% of TAX (VAT) (TNGST with FORM-17)	
20	% of TAX (VAT) without form	
21	% of TAX (CST) (CST with C-FORM)	
22	% of TAX (CST) without form	
23	Packing & Forwarding Charges ( in % only)	
24	<b>Freight &amp; transit insurance charges, if any(( in % only)</b> Freight charges from Dispatching station to BHEL <b>TRICHY (TN)</b> (Note: If the delivery terms is Ex Works the materials has to be sent through BHEL approved carrier only ,in this case the freight will be borne by BHEL)	
25	Approximate Net weight of the total consignment	
26	Approximate Gross weight of the total consignment	
27	Approximate Dimensions of the Consignment	
28	Name of the contact person	
29	Land Line Number	
30	Fax Number	
31	Mobile Number	
32	E-mail ID	
33	PAN No.	
34	CST No.	TIN No.

- a) It is confirmed that all the terms and conditions stipulated in the Enquiry have been fully understood by us and all clarifications & details have been obtained.
- b) Applicable % of ED, Sales Tax -CST or VAT, Service Tax), Freight, Insurance and Installation and Commissioning Charges etc., are indicated in offer.

Full postal Address:

Signature & Office Seal of the vendor

**Note:-**

Your specific acceptances to our Payment terms, LD & Risk Purchase (RP) Clause are essential for consideration of your offer. Otherwise your offer is liable for rejection.

No row shall be left blank. Please indicate NA, in case the item is “**not applicable**”

**PART - II**

**MODEL PRICE BID FORMAT FOR INDIAN BIDDERS**

Enquiry No. & Date:

Bidder's Offer No. & Date:

SI No	Description of item	Unit (SET /No)	QTY	Rate /Qty in Rs. (excluding of all taxes)	VAT/CST in % (TNGST with FORM-17 or CST with C-FORM)	ED in % (EXTRA / INCLUSIVE / NIL)	Total Value in Rs. (inclusive of all taxes)
	Packing & Forwarding charges (if any) in percentage (or) Lumpsum						
	FOR Dispatching station value in Rs.						
	Percentage of Freight & transit insurance charges, if any (Lumpsum or %) Freight & Insurance charges from Dispatching station to BHEL, TRICHY (TN) (Note:If the delivery terms is Ex Works the materials has to be sent through BHEL approved carrier only, in this case the freight & Insurane will be borne by BHEL)						
	Approximate Net weight of the total consignment						
	Approximate Gross weight of the total consignment						
	Approximate Dimensions of the Consignment						

Signature & Seal of Vendor

**The price bid should be submitted only as per the above format. No row shall be left blank. Please indicate NA, in case the item is "not applicable"**

**Terms & Conditions of Reverse Auction**

Against this enquiry for the subject item/ system with detailed scope of supply as per enquiry specifications, BHEL may resort to "REVERSE AUCTION PROCEDURE" i.e., ON LINE BIDDING (THROUGH A SERVICE PROVIDER). The philosophy followed for reverse auction shall be English Reverse (No ties).

1. For the proposed reverse auction, technically and commercially acceptable bidders only shall be eligible to participate.
2. Those bidders who have given their acceptance for Reverse Auction (quoted against this tender enquiry) will have to necessarily submit „online sealed bid" in the Reverse Auction. Non-submission of "online sealed bid" by the bidder for any of the eligible items for which techno-commercially qualified, will be considered as tampering of the tender process and will invite action by BHEL as per extant guidelines in vogue.
3. BHEL will engage the services of a service provider who will provide all necessary training and assistance before commencement of on line bidding on internet.
4. In case of reverse auction, BHEL will inform the bidders the details of Service Provider to enable them to contact & get trained.
5. Business rules like event date, time, bid decrement, extension etc. also will be communicated through service provider for compliance.
6. Bidders have to fax the Compliance form before start of Reverse auction. Without this, the bidder will not be eligible to participate in the event.
7. In line with the NIT terms, BHEL will provide the calculation sheet (e.g., EXCEL sheet) which will help to arrive at "Total Cost to BHEL" like Packing & forwarding charges, Taxes and Duties, Freight charges, Insurance, Service Tax for Services and loading factors (for non-compliance to BHEL standard Commercial terms & conditions) for each of the bidder to enable them to fill-in the price and keep it ready for keying in during the Auction.
8. Reverse auction will be conducted on scheduled date & time.
9. At the end of Reverse Auction event, the lowest bidder value will be known on auction portal.

10. The lowest bidder has to fax/e-mail the duly signed and filled-in prescribed format for price breakup including that of line items, if required, as provided on case-to-case basis to Service provider within two working days of Auction without fail.
11. In case BHEL decides not to go for Reverse Auction procedure for this tender enquiry, the Price bids and price impacts, if any, already submitted and available with BHEL shall be opened as per BHEL's standard practice.
12. Bidders shall be required to read the "Terms and Conditions" section of the auctions site of Service provider, using the Login IDs and passwords given to them by the service provider before reverse auction event. Bidders should acquaint themselves of the „Business Rules of Reverse Auction", which will be communicated before the Reverse Auction.
13. If the Bidder or any of his representatives are found to be involved in Price manipulation/ cartel formation of any kind, directly or indirectly by communicating with other bidders, action as *per extant BHEL guidelines*, shall be initiated by BHEL and the results of the RA scrapped/ aborted.
14. The Bidder shall not divulge either his Bids or any other exclusive details of BHEL to any other party.
15. In case BHEL decides to go for reverse auction, the H1 bidder (whose quote is highest in online sealed bid) may not be allowed to participate in further RA process.

# ANNEXURE -C

## CHECK LIST FOR RA CONDUCTANCE

<p>General terms and conditions, Commercial terms and conditions acceptance for participation in Reverse auction (RA) <b>on cumulative L1 L1 basis( package basis) for Item SL.NO.10-90, &amp; item SL.NO. 100-180</b></p> <p><b>Yes/No to be indicated</b></p>	<p><b>Vendor's confirmation- Yes/No</b></p> <p>.....</p>
<p>Name of the person for participating in reverse auction.</p>	
<p>Land Line Number</p>	
<p>Fax Number</p>	
<p>Mobile Number</p>	
<p>E-mail ID</p>	