



# Bharat Heavy Electricals Limited

(High Pressure Boiler Plant)

Tiruchirappalli – 620014, TAMIL NADU, INDIA

CAPITAL EQUIPMENT / MATERIALS MANAGEMENT

An ISO 9001  
Company

<b>ENQUIRY NOTICE INVITING TENDER</b>	Phone: +91 431 257 79 38 Fax : +91 431 252 00 31 Email : <a href="mailto:tvenkat@bheltry.co.in">tvenkat@bheltry.co.in</a> Web : <a href="http://www.bhel.com">www.bhel.com</a>
---	---

<b>TWO PART BID</b> Tender to be submitted in two Parts	<b>Enquiry Number:</b> 2851400030	<b>Enquiry Date:</b> 08.05.2014	<b>Due date for submission of quotation:</b> 12.06.2014
--	--------------------------------------	------------------------------------	--

You are requested to quote the Enquiry number date and due date in all your correspondence. This is only a request for quotation and not an order.  
Please note that under any circumstances both delayed offer and late offers will not be considered. Hence vendors are requested to ensure that the offer is reaching physically our office before 14.00 hrs on the Date of tender opening.

Item	Description	Qty.	Delivery Required	Delivery Terms Required
10	Continuous Discharge Roller Hearth Furnace as per the technical specification & commercial conditions applicable (to be downloaded from web site <a href="http://www.bhel.com">www.bhel.com</a> or <a href="http://tenders.gov.in">http://tenders.gov.in</a> )	1 No.	31.01.2015	F.O.R, BHEL Stores, POWER EQUIPMENT FABRICATION PLANT, BHARAT HEAVY ELECTRICALS LIMITED, Mundlpar- 441804, Sakoli Taluk, Bhandara District, Maharashtra State.

**Important points to be taken care during submission of offer:-**

1. Compliance Form No. BND/IND/05 and Annexure II (Details of Company Performance) to be filled and enclosed along with the offer failing which, the offer will not be considered for evaluation.
2. EMD for this Tender will be Rs. 2,00,000.00/-
3. All updates, amendments, corrigenda, etc., (if any), for each tender will be posted only on the above websites from time to time, as and when required, until each tender is opened. There will be no publication of such updates, amendments, corrigenda, etc., through newspapers or any other media.
4. The time period required for Erection & Commissioning of the Item shall be 10 weeks from the date of intimation from BHEL requesting supplier to depute Service Engineers about site readiness

BHEL's General guidelines / instructions (refer MM/CE/GENL/001-EMD) including bank guarantee formats and list of consortium banks, commercial terms check-list can be downloaded from BHEL web site <http://www.bhel.com> or from the Government tender website <http://tenders.gov.in> (public sector units > Bharat Heavy Electricals Limited page) under Enquiry reference "2851400030".

Tenders should reach us before 14:00 hours on the due date Tenders will be opened at 14:30 hours on the due date Tenders would be opened in presence of the tenderers who have submitted their offers and who may like to be present	Yours faithfully, For <b>BHARAT HEAVY ELECTRICALS LIMITED</b>  Sr. Manager / Capital Equipment / MM
--	--

**T. VENKATESWARAN**  
-Senior Manager  
Capital Equipment / MM  
BHEL, Tiruchirappalli - 620 014.

**PART A****CONTINUOUS DISCHARGE ROLLER HEARTH FURNACE****SECTION – I: QUALIFYING CRITERIA**

The BIDDER has to compulsorily meet the following requirements to get qualified for considering the technical offer:

S.No.	REQUIREMENTS	VENDOR'S RESPONSE
1.0	The Bidder/Vendor (OEM) shall have a minimum of TEN years continuous experience in Design, manufacturing and supply of Continuous Discharge Roller Hearth Furnace. Vendor shall indicate the actual no.of years of experience in this field.	
1.1	<p>Only those vendors (OEMs) should quote, who have commissioned in the last 10 years (as on the original date of tender opening) at least ONE <b>“LPG FIRED CONTINUOUS DISCHARGE ROLLER HEARTH FURNACE with ALL the following conditions:</b></p> <p>a) <b>Charge heating temperature of 800 deg C or higher</b></p> <p>b) <b>Charge weight carrying capacity of roller conveyer to be 7 Tons or more</b></p> <p>c) <b>Job width of 3 metres or more</b></p> <p>EITHER (i) In at least any one country other than the country of origin to establish vendor's global business activity. OR(ii) In India</p> <p>and the referred furnaces are presently working satisfactorily for more than one year from the date of commissioning (as on the original date of tender opening). The name and contact addresses of the customers to whom the above mentioned furnaces were supplied to be furnished with details.</p>	
1.2	<p>Vendor has to submit at least <b>One Performance Certificate</b> from their customers in India or from the customers to whom the furnace was supplied outside the country of origin, referred under clause 1.1 above , for a minimum period of one year from the date of commissioning (as on original date of tender opening).</p> <p>Performance certificate as original certificate or Email directly from the customer may be submitted. The original certificate may be returned after verification by BHEL, if required.</p> <p>For obtaining the Performance certificate, a suggestive format is provided at the end of Part-A</p>	
1.3	<p>BHEL reserves the right to verify the information provided by vendor for the referred furnace at their referred customer's works. It shall be the responsibility of the vendor to facilitate the visit of BHEL's team at their referred customer works. The travel, Board and Lodging expenses for BHEL personnel shall be borne by BHEL. In case the information provided by vendor is found to be false/ incorrect, the offer shall be rejected.</p> <p>BHEL reserves the right to accept or reject the OEMs based on assessment of their technical and financial capability.</p>	

**SECTION – II**

The BIDDER / VENDOR is requested to provide the following information:

<b>S.No.</b>	<b>REQUIREMENTS</b>	<b>VENDOR's RESPONSE</b>
2.1	The BIDDER/VENDOR to furnish Reference List of Customers, with full address, details of contact person, where Continuous Discharge Roller Hearth furnace have been supplied in the past.	
2.2	Details of Continuous Discharge Roller Hearth furnace supplied to other BHEL units, if any. (Year of commissioning, Length, Width, capacity and Operating temperature)	
2.3	Details on SERVICE-AFTER-SALES Set-Up in India including the Address of Agents / Service Centers in Central India.	
2.4	Any Additional Data to supplement the manufacturing capability of the BIDDER for the subject equipment.	

**SECTION – III**

The BIDDER / VENDOR to note:

<b>S.No.</b>	<b>REQUIREMENTS</b>	<b>VENDOR's RESPONSE</b>
3.1	The BIDDER/VENDOR shall submit the offer in TWO parts 1. Technical offer [ <b>with PART A &amp; PART B</b> ] 2. Commercial offer and price bid	
3.2	The Technical Offer shall contain complete details against all clauses of technical specifications given by BHEL	
3.3	The Technical Offer shall be supported by copies of product- catalogues, data sheets and technical details of Bought-Out-Items.	
3.4	The commercial offer (given with technical offer) shall contain the scope of supply and Un-priced part of the Price-Bid, for confirmation	

**Suggestive Format of Performance Certificate:**

The performance should be certified by the customer on **Customer's Letter Head** and to be submitted along with the offer

**PERFORMANCE CERTIFICATE**

1.0	Supplier of the Equipment	
2.0	Make & Model number	
3.0	Month & Year of Commissioning	
4.0	Application for which Equipment is used	
5.0	a) Length of furnace	
	b) Width of furnace	
	c) Height of the furnace	
	d) Operating Temperature	
	e) Weight Carrying Capacity of Rollers Conveyor in Tons	
	f) Burner type: PID with MFC controlled or pulse fired system	
6.0	Performance of the Equipment (Strike off whichever is not applicable)	Satisfactory / Not Satisfactory
7.0	After sales service (Strike off whichever is not applicable)	Satisfactory / Not Satisfactory
8.0	Any Other remarks	
<p>Date: _____ Signature &amp; Seal of the Authority Issuing the Performance Certificate</p>		

**PART B**

**CONTINUOUS DISCHARGE ROLLER HEARTH FURNACE**

Sl.No.	DESCRIPTION	SPECIFICATION	BIDDER'S OFFER
<b>1.0</b>	<b>PURPOSE &amp; JOB MATERIAL:</b>		
1.1	Purpose: Stress Relieving of all tubular coils & Panels forming pressure parts of Utility Boilers ,Industrial and Supercritical Boilers		
1.2	<b>Job Details:</b> Material: Carbon Steel & Alloy Steels Jobs: Tubular Coils & Panels Tube Diameter Range: 28.6 to 76.1 mm OD Wall Thickness: 2.4 to 18 mm Job Length: Up to 24 M Job Width: Up to 3500 mm Weight of Job Lot: Not exceeding 9 Tons		
<b>2.0</b>	<b>FURNACE:</b>		
2.1	<b>Operating Parameters:</b>		
2.1.1	Charge Capacity	9 Tons	
2.1.2	Heat Treatment Cycles to be carried out	Stress Relieving	
2.1.3 a)	Maximum Charge Temperature	800 Deg C	
2.1.3 b)	Maximum Furnace Temperature	Vendor to specify	
2.1.3 c)	Rate of Heating (selection has to be infinitely variable in the range specified)	35 to 200 degC / Hour	
2.1.3 d)	No of Zones	Four	
2.1.4	Job Temperature Uniformity in all 4 zones of the furnace	± 10 DegC	
2.1.5	Fuel	LPG(Propane+Butane)/Propane	
<b>2.2</b>	<b>Furnace Configuration</b>		
2.2.1	Fuel – LPG(Propane+Butane)/Propane Gas Fired firing system		

Continuous Discharge Roller Hearth Furnace

Sl.No.	DESCRIPTION	SPECIFICATION	BIDDER'S OFFER
2.2.2	Roller Hearth Type with Vertical Lifting Doors partially open depending on job height in Continuous Discharge Mode. Vendor to provide proper guide ways for smooth vertical movement of furnace doors to ensure heat loss prevention and to maintain zone temperature		
2.2.3	Automatic Zone Temperature Control with Programming of Heat Treatment Cycle.		
2.2.4	Ceramic Fiber block module Lining( roof and doors)		
2.2.5	Hard refractory brick construction on the side walls and hearth		
2.2.6	Recuperator System for Energy Conservation		
2.2.7	Chamber Rollers. Charge (Infeed) and Discharge Roller Tables		
2.3	<b>Furnace Chamber Inside (Effective) Dimensions</b>		
2.3.1	Width of the furnace(after refractory lining)	3850 mm	
2.3.2	Inside Length from Front Door to Back Door(after refractory lining)	16000 mm	
2.3.3	Inside Height (above Roller to roof refractory lining)	800 mm	
2.4	<b>Combustion System:</b>		
2.4.1	The furnace has to be provided with the required number of nozzle-mix high velocity burners suitably designed for firing LPG(Propane+Butane)/Propane. The positioning of the burners inside the furnace should be designed to create high degree of turbulence in the furnace atmosphere, increased convection heat transfer co-efficient, resulting in better uniformity and thermal efficiency even at lower temperature. Vendor to Confirm		
2.4.2	LPG(Propane+Butane)/Propane line Pressure-BHEL can supply at 1.5 to 2.0 kg/cm <sup>2</sup> Vendor to Confirm		
2.4.3	Max required flow rate of LPG(Propane+Butane)/Propane (Supporting heat calculation details to be enclosed). Vendor to Specify		
2.4.4	Burners Type - (High Velocity Burner of <b>Kromschroder/Eclipse</b> or any reputed make acceptable to BHEL) (Vendor to furnish model no. and technical details of burners). Vendor to furnish details		

Continuous Discharge Roller Hearth Furnace

Sl.No.	DESCRIPTION	BIDDER'S OFFER [with technical details]
2.4.5	Number of rows and arrangement of Burners (Schematic drawing should be furnished along with the offer). Vendor to Specify	
2.4.6	<b>Number of Burners</b> (Calculation details should be submitted with the offer). Vendor to Specify	
2.4.7	Burner Rating. Vendor to Specify	
2.4.8	Burner turn - down ratio (higher ratio is preferred). Vendor to Specify	
2.4.9	Flame Length. Vendor to Specify	
2.4.10	Furnace Control System: The vendor shall offer both the following systems. 1.PID with Mass Flow Control and 2. Pulse-fired system. However the Type of Furnace control system will be finalized by BHEL at the time of technical discussion.Vendor to Confirm.	
2.4.11	No. of Temperature control Zones- Four. Vendor to confirm	
2.4.12	LPG (Propane+Butane)/Propane gas burner material of construction shall be SS 310/Grey Cast Iron inside portion. Vendor to Confirm	
2.4.13	LPG (Propane+Butane)/Propane gas igniter material of construction shall be SS 310/Kanthal A1 with ceramic body. Vendor to Confirm	
2.4.14	Two ways solenoid valve shall be brass/aluminium material and should be flame proof as per IS: 2148 gas group class IIA, IIB. Vendor to Confirm	
2.4.15	Isolation valves shall be fire safe design as per IS: 2148. Vendor to Confirm	
2.4.16	Vent valves opening position to be indicated in the control panel. Vendor to Confirm	
2.4.17	All vent valves shall be routed above roof to better air mix up in atmosphere. Vendor to Confirm	
2.4.18	All valve flanges shall be raised face with serrations. Vendor to Confirm	
2.4.19	Wherever electrical input is available with any instrument in the LPG(Propane+Butane)/Propane line such as Igniter cables, scanner related items, junction boxes, transmitter, limit switches shall be flame proof enclosure with double compression cable gland provision for cable entry/exit. Vendor to Confirm	
2.4.20	All cables should be Flame Retardant Low Smoke design only. Vendor to Confirm	
2.4.21	Copper cladded asbestos gasket to be used for valve flanges. Vendor to Confirm	
2.4.22	The complete piping system with all mechanical components should withstand Max 6 bar pressure during initial testing .Vendor to Confirm	

Continuous Discharge Roller Hearth Furnace

Sl.No.	DESCRIPTION	BIDDER'S OFFER [with technical details]
2.4.23	2 Nos. of "y" type / simplex filter with 4 Nos. of isolation valves to be provided. Vendor to Confirm	
2.4.24	Instrument impulse line shall be SS 316, Sch 40. Vendor to Confirm	
2.4.25	Copper washer shall be provided to all pressure gauges and switches. Vendor to Confirm	
2.4.26	All Flanges should be provided with copper earthing. Vendor to Confirm	
2.4.27	One spectacle blind shall be provided for each furnace near terminal point at gas train piping. Vendor to Confirm	
2.4.28	Full TIG welding shall be carried out for all welding joints in LPG(Propane+Butane)/Propane line. Vendor to Confirm	
2.4.29	Provide one push button-type isolation valve for all pressure gauge /pressure switch. Vendor to Confirm	
2.4.30	<b>Forced Draught (FD) Fan:</b>	
a)	FD Fan with VFD of suitable capacity (including excess air) has to be provided to ensure proper combustion and controlled cooling for SR (whenever required). VFD drive should be of SIEMENS (preferably Sinamics) / YASKAWA/ABB/ ALLEN BRADLEY/MITSUBHISHI makes only. Vendor to Specify.	
b)	Air flow-calculation details to be submitted with offer. Vendor to Confirm	
c)	Air Pressure. Vendor to Specify	
d)	Power Rating (KW). Vendor to Specify	
e)	Type of blower: Centrifugal. Vendor to Confirm	
f)	Make of Blower: C-Doctor/Patel/Flakt preferred. Vendor to specify	
2.4.31	<b>Induced Draught (ID) Fan:</b>	
a)	ID Fan of suitable capacity to be provided before the stack. Vendor to Confirm	
b)	Air flow-Calculation details to be submitted with offer. Vendor to Confirm	
c)	Air Pressure. Vendor to Specify.	
d)	Power Rating (KW). Vendor to Specify.	
e)	Type of blower: Centrifugal- Vendor to Confirm	
f)	Make of Blower: C-Doctor/Patel/Flakt preferred. Vendor to specify	
2.4.32	The FD Fan and ID Fan have to be suitably sized to ensure a Balanced Draught System. Drive mechanism for FD and ID fans should be of belt drive. Vendor to Confirm	
2.4.33	A standby fan each for both FD and ID system has to be provided. Vendor to Confirm	

Sl.No.	DESCRIPTION	BIDDER'S OFFER [with technical details]
2.4.34	Bell mouth (Silencer) inlet to be provided with suitable filter on the suction side of FD fan. Vendor must provide suitable handling facility for cleaning the filter element by one person. Vendor to Confirm	
2.4.35	All the motors used for the fans shall be of Energy efficient (EFF1) class conforming to IEC/IS standards. Vendor to confirm	
2.4.36	<p>All the Fans (FD &amp; ID) should comply with the following test parameters:</p> <ol style="list-style-type: none"> <li>1. Impeller blades are to be fully welded.</li> <li>2. Availability of sufficient strengthening stiffeners in the body / support structure of the blower.</li> <li>3. Noise level: Max. 85 ± 3 dBA @ 1.5 meter distance.</li> <li>4. Vibration level: As per ISO-14694. Up to 4.8 mm/sec (RMS) with foundation</li> <li>5. Dynamic balancing of impeller at rated speed.</li> </ol> <p>Vendor to confirm</p>	
2.4.37	<b>Dampers:</b>	
a)	Damper has to be provided after the furnace hearth and before the stack in the flue gas path to regulate draught. Vendor to Confirm	
b)	The damper has to work on auto mode and its opening should get adjusted automatically depending upon the draught required in the furnace (positive).(Complete details should be furnished with the offer). Vendor to provide details.	
c)	Provision should be there to operate the damper in manual mode also. Vendor to Confirm	
2.5	<p><b>Refractory Lining:</b> (For roof, doors) Ceramic fiber blocks modules with back up layer of suitable density and thickness (conforming to ASTM-892-C-1993) to ensure that the skin temperature of the furnace does not exceed 80 deg C. The anchor material should be SS304.</p> <ol style="list-style-type: none"> <li>1. Vendor to furnish calculations of the insulation material &amp; also data sheet of the insulating material</li> <li>2. The supplier shall provide MSDS for all refractory material (including ceramic wool) – It shall cover “cradle to grave”.</li> <li>3. The supplier shall indicate the applicability of the ceramic material under Hazardous Wastes Management, Handling and Trans boundary Movement) Rules, 2008.</li> </ol> <p>Vendor to Confirm</p>	

Continuous Discharge Roller Hearth Furnace

Sl.No.	DESCRIPTION	BIDDER'S OFFER [with technical details]
2.5.1	<b>Size of Ceramic Fiber Block Modules</b> (Size should be under the standard manufacturing range of the supplier). Vendor to Specify	
2.5.1.1	Density of ceramic fiber block module- Vendor to Specify	
2.5.1.2	Thickness of ceramic fiber block module- Vendor to Specify	
2.5.1.3	Max. Service Temperature of ceramic fiber block module- Vendor to Specify	
2.5.1.4	Make: M/s MMTCL or M/s Unifrax only- Vendor to Specify	
2.5.2	<b>Size of Back up Blanket layer</b> ( Size should be under the standard manufacturing range of the supplier). Vendor to Specify	
2.5.2.1	Density of backup blanket layer- Vendor to Specify	
2.5.2.2	Max. Service Temperature of backup blanket layer- Vendor to Specify	
2.5.2.3	Thickness of backup blanket layer- Vendor to Specify	
2.5.2.4	Make: M/s MMTCL or M/s Unifrax only- Vendor to Specify.	
2.6	<b>Furnace Hearth and side walls:</b>	
2.6.1	Inside the Fixed hearth and side walls to be lined with hard refractory & Insulation brick construction with Calcium silicate board backup of suitable thickness and combination to ensure that the skin temperature of the furnace does not exceed 80 deg.C. Vendor to Confirm	
2.6.2	The peripheral refractory has to be held and supported by a set of heat resisting grey cast iron castings, conforming to IS 4522, grade 9. Vendor to Confirm	
2.6.3	Make of Hard refractory materials: M/s ACE, M/s Maithan refractories, M/s TATA refractories, M/s Corborundam Universal or any other make acceptable to BHEL. (Relevant data sheets to be submitted in the offer). Vendor to Specify.	
2.7	<b>Burner blocks:</b> 90% High Alumina Material or SIC material	
2.8	<b>Furnace Doors:</b>	
2.8.1	Number of Doors - Two	
2.8.2	Steel construction with ceramic fiber modules lining system inside and a set of heat resisting grey cast iron castings, conforming to IS 4522, grade 9 around the periphery of the door and with suitable counter balance arrangement. Vendor to Confirm	
2.8.3	Operation- Vertical. Vendor to confirm.	
2.8.4	Drive: Electric drive with Speed reduction Gear Box, Electromagnetic Brake etc. for each door at ground level. Vendor to confirm	

Sl.No.	DESCRIPTION	BIDDER'S OFFER [with technical details]
2.8.5	Drive Motor Rating. Vendor to Specify	
2.8.6	Door limit switches should be provided suitably. Vendor to confirm.	
2.8.7	The Periphery of the doors has to be designed suitably so that positive sealing is established with the furnace by the door in closed position. Vendor to confirm	
2.8.8	In the unlocked position, and while lifting the door, it should move away from the opening and slide up on the cast iron end plates of the furnace without interfering on any furnace structure. Vendor to confirm	
2.8.9	The counter weight arrangement should be provided on the sides of the doors. The counter weight should be positioned in a cage and should be properly guided inside the cage on either sides of the doors. Vendor to confirm.	
<b>2.9</b>	<b>Furnace Construction (General):</b>	
2.9.1	The complete furnace structure including the sidewalls and roof are to be manufactured from rolled steel sections and plates of suitable thickness (Min 10mm) (Complete details should be furnished with the offer). Vendor to Specify.	
2.9.2	The various load bearing members are to be designed conservatively to ensure rigidity of the complete casing. Vendor to confirm	
2.9.3	A schematic diagram showing the layout of the furnace & associated systems with salient dimensions should be furnished along with the offer. Vendor to confirm	
<b>2.10</b>	<b>RECUPERATOR:</b>	
2.10.1	The recuperator shall be of metallic with counter flow heat transfer arrangement. Material of construction of hot face shall be SS304 (Complete details of construction should be furnished with the offer). Vendor to confirm and furnish details.	
2.10.2	Recuperator has to pre-heat the air to minimum 250 degC. Recuperator Bypass with suitable valves to be provided- <b>Thermal calculation to be enclosed.</b>	
2.10.3	The recuperator has to be located suitably in the flue gas path above the ground. Vendor to confirm	
2.10.4	On line indication of inlet, exit temp of air and flue gas to be available. Vendor to confirm	

Sl.No.	DESCRIPTION	BIDDER'S OFFER [with technical details]
2.11	<b>FLUE DUCT:</b>	
2.11.1	Flue duct Position (Suitably insulated preferably with hard refractory). Flue duct routing to be considered on top/rear/side suitably to ensure high furnace efficiency and to maintain uniform temperature inside the furnace; Flue duct routing below the ground level is not acceptable. Vendor to Specify	
2.12	<b>STACK:</b>	
2.12.1	Furnace is located inside the shop. So the routing/design of stack for flue gas outlet to take care for passing the stack through the roof. The stack for flue gas outlet has to be designed and constructed with suitable insulation and venture suitably to leave the waste gas at a lowest temperature without dilution. Vendor to provide details.	
2.12.2	Stack design should consider the following points <ul style="list-style-type: none"> <li>• The stack will be located approximately at the centre of shop columns and will be passing through the roof</li> <li>• The width/dia of the stack portion located between the columns and passing through the roof should not be more than the width of the column (around 1.2m)</li> <li>• Proper supports for exhaust duct and stack to be provided</li> </ul> Vendor to provide details.	
2.12.3	Chimney/stack height shall satisfy the requirements of <b>Maharashtra Pollution Control Board (MPCB)</b> norms with respect to emission of SO <sub>x</sub> ; NO <sub>x</sub> and Suspended Particulate Matter (SPM). The guidelines to calculate the chimney height is as follows: $H = 14 (Q)^{0.3}$ Q – SO <sub>x</sub> emission rate in Kg/hr; H – Height of stack in meters from ground level.  However the height of the chimney/stack shall be the Height calculated by the above formula OR <b>25m</b> (passing through the shop roof) whichever is higher. Vendor to Specify	
2.12.4	Four port holes at 90 deg shall be provided at two different elevations around the stack. Each porthole shall be of 100 mm inner diameter, welded with a standpipe 100 mm long fixed with a flange and bolted with a dummy plate. Vendor to specify the height/elevation of port holes based on pollution control norms. The exact height/elevation shall be decided during technical discussion. Vendor to confirm	

Continuous Discharge Roller Hearth Furnace

Sl.No.	DESCRIPTION	BIDDER'S OFFER [with technical details]
2.12.5	<ul style="list-style-type: none"> <li>• Vendor to provide ladder with hand rails to reach both the sampling points/platforms.</li> <li>• Platform with toe guard to be provided all around the chimney 1m below the sampling plane preferably. Safe Approach/accessibility to reach the top of the chimney to be provided.</li> </ul> Vendor to provide details of arrangement.	
2.12.6	The stack shall be provided with a weather cowl and red indicating lamp for high rise structure. The lamp should be able to withstand high temperatures of the exhaust/flue gases. Vendor to Confirm	
2.12.7	Stack to be provided with complete lightning arrester system including lightning arrester spike, copper conductor tape from spike to test link, test link, earth pit as per Indian standards. Vendor to Confirm	
2.12.8	Exit temperature, Oxygen, SPM (in mg/cu.m), SPM (Microns), Sox; NOx; CO; flue gas velocity at the outlet tip of the chimney. Vendor to Specify	
2.12.9	The demonstration (proving) of the parameters as per 2.12.8 is in the scope of vendor. Necessary calibrated measuring instruments used for this purpose is in the scope of the supplier. Emission certificate conforming to MPCB norms from authorized body/lab to be provided by the supplier after commissioning the furnace. Vendor to Confirm	
<b>2.13</b>	<b>ROLLER CONVEYOR SYSTEM:</b>	
2.13.1	The Roller Conveyor System shall comprise of an In feed (Charge) Table, Furnace Roller Hearth, and a Discharge Conveyor(Complete details should be furnished with the offer). Vendor to Confirm	
2.13.2	Drive shall be transmitted to the rollers by means of standard roller chain and double sprockets, the sprockets being keyed into the roller shaft. Vendor to Confirm	
2.13.3	The entire installation have a speed range of 75 mm to 450 mm per minute. Vendor to confirm	
2.13.4	Motorized Drive Type and Rating (VVFD). Vendor to Specify	
2.13.5	Make of VVFD--- SIEMENS (preferably Sinamics) / YASKAWA/ ABB /ALLEN BRADLEY/MITSUBHISHI makes only. Vendor to Specify.	
2.13.6	The roller chain drives and associated mechanisms for the charge and discharge tables are to be provided with suitable guards with provision for lubrication and maintenance. (Complete details should be furnished with the offer). Vendor to confirm	
2.13.7	A stand by drive system for Furnace rollers to be provided. If one drive system fails, automatic switch over to the other drive system can be provided. Drive system of furnace rollers should be capable of providing continuous motion and oscillatory motion of furnace rollers. Vendor to provide details.	
<b>2.13.8</b>	<b>In-feed (Charge Table):</b>	
	a) Type - Roller Table	

Continuous Discharge Roller Hearth Furnace

Sl.No.	DESCRIPTION	BIDDER'S OFFER [with technical details]
	b) Length-24000 mm. Vendor to Confirm	
	c) Width- Around 3800 mm. Vendor to specify	
	d) Roller material- Mild Steel	
	e) Number of rollers/Roller Spacing- Preferred spacing 850mm	
	f) Roller size –as per 3M18B1013584/01.Vendor to confirm	
	g) Roller mounting & bearing arrangement. Vendor to specify	
	h) The entire roller table to be supported by a structural steel framework. Vendor to confirm	
	i) Suitable side guides to contain the load on the roller are to be provided. Vendor to confirm	
<b>2.13.9</b>	<b>Discharge Table:</b>	
	a) Type - Roller Table	
	b) Length-24000 mm. Vendor to Confirm	
	c) Width- Around 3800 mm. Vendor to Specify	
	d) Roller material- Mild Steel	
	e) Number of rollers/Roller Spacing- Preferred spacing 850mm- Vendor to Specify	
	f) Roller size –as per 3M18B1013584/01- Vendor to confirm	
	g) Roller mounting & bearing arrangement- Vendor to specify	
	h) The entire roller table to be supported by a structural steel framework. Vendor to confirm	
	i) Suitable side guides to contain the load on the roller are to be provided. Vendor to confirm	
<b>2.13.10</b>	<b>Furnace Rollers:</b>	
	a) Material- Mo-Re No.1 alloy containing a minimum of 25% Ni and 20% chromium. Vendor to confirm	
	b) Type- Centrifugally Cast. Vendor to confirm	
	c) Roller size –as per Drg 2M18B1004708/02. vendor to confirm	
	d) Number of rollers -32 Rollers equally spaced. vendor to confirm	
	e) Roller mounting & bearing (self-aligning) arrangement. Vendor to specify	
	f) Provision to be made on the mountings to enable accuracy of alignment of the rollers. Vendor to specify	
2.13.11	Roller bearing capacity: All the rollers and bearings to be designed for conveying a coil/panel of 9 tons with 16m(length) and 2.5m(width). Vendor to confirm.	

Sl.No.	DESCRIPTION	BIDDER'S OFFER [with technical details]
2.13.12	Vendor to specify the load bearing capacity of conveyor in kg/meter.	
<b>2.14</b>	<b>PIPELINES &amp; VALVES:</b>	
2.14.1	BHEL will provide LPG (Propane+Butane)/Propane at one point near the furnace. All piping for LPG (Propane+Butane)/Propane to the furnace gas control valves and to other points is in the scope of the vendor. 1.5 to 2Kg/sq.cm Regulator to be provided at the start of the Gas train system for fine tuning. Vendor to confirm	
2.14.2	All air piping from the fans to the control valves and to other points is in the scope of the vendor. Vendor to confirm	
2.14.3	Required valve for control of gas and air is in scope of the vendor. Vendor to confirm	
2.14.4	All hot air pipe lines to be insulated. Vendor to confirm	
2.14.5	All the pipe lines to be installed above ground level. Vendor to confirm	
2.14.6	Make of Gas & Air valves used shall be of Kromschroder/Samson Mumbai/IL Palghat/MIL Chennai/ Fouress Bangalore/Fisher Xomas Chennai/ Eclipse/ Dungs/ Audco/ Flowjet. Vendor to specify	
2.14.7	Gas valves, air valves & field instruments in gas line must be fire proof as per NFPA. Vendor to specify.	
<b>2.15</b>	<b>ELECTRICAL:</b>	
2.15.1	Tropicalization: All electrical / electronic equipment shall be tropicalized. Vendor to Confirm	
2.15.2	All Electric enclosures shall have IP 54 protection. Vendor to Confirm	
2.15.3	All electrical components in the cabinets should be mounted on DIN Rail. Vendor to Confirm	
2.15.4	<p>a) 415V with fluctuation of +/- 10%, 50Hz +/-3 %, 3 Phase AC power supply will be provided by BHEL at a single point near the furnace in the control room, as per layout recommended by Vendor.</p> <p>b) All cables, connections, circuit breakers etc. required for connecting BHEL's power supply point to different parts of the equipment/control cabinets, shall be the responsibility of vendor. All cables should be of copper only.</p> <p>c) Requirement of grounding/earthing with required material details should be informed by vendor well in advance so that it could be incorporated during construction of foundation. BHEL will provide earth pits at pre-designated locations. Vendor has to make all required connections to the earth pit. Separate earthing should be provided for main power panels, Burner control panels and Chimney lightning arrester, each to be terminated at individual earth pits. Earth flats should be GI (25 mm X 3 mm). Appropriate length GI flats for earthing are vendor's scope.</p> <p><b>Vendor to Confirm</b></p>	

Sl.No.	DESCRIPTION	BIDDER'S OFFER [with technical details]
2.15.5	All electrical and electronic panels including operator's panel should be provided with fluorescent lamps for sufficient illumination and power receptacles of 220 Volts, 5/15 Amp AC. All adapters / receptacles should have compatibility with Indian equivalents. All single phase power supply/control voltage should be 230 V, 50 Hz. Vendor to Confirm	
2.15.6	Motors & other electrical/Instrumentation components shall conform to IEC or Indian Standards. Only copper core cable to be used. Motors shall be of energy efficient (EFF1) and makes of ABB / Siemens / Kirloskar / Bharat Bijlee / Hindustan / Crompton Greaves/NGEF or any other make acceptable to BHEL. Vendor to Specify.	
2.15.7	All the metallic cable trays required for laying of cables should be included in the offer. Vendor to Confirm	
2.15.8	Vendor should ensure the proper earthing for the furnace and its peripherals. Vendor to Confirm	
2.15.9	All electrical components like contactors, OLRs, Switches, Push buttons etc., should be of BCH/Siemens/ Telemecanique /L&T/ SCHNEIDER/GE make and VVFD for fan shall be of SIEMENS(preferably Sinamics) / YASKAWA/ABB/ ALLEN BRADLEY/MITSUBHISHI make. The VVFDs shall take reference from controller output (4-20mA) to ensure controlled and efficient blower operation during furnace heating and cooling cycles. Vendor to specify	
<b>3.0</b>	<b>SAFETY ARRANGEMENTS:</b>	
3.1	Following safety features in addition to other standard safety features should be provided to the machine: Vendor to Confirm	
3.2	Furnace should have adequate and reliable safety interlocks / devices to avoid damage to the furnace, work piece and the operator due to the malfunctioning or mistakes. Furnace functions should be continuously monitored and alarm / warning indications through lights/ alarm number with messages on panels should be available. Vendor to specify	
3.3	A detailed list of all alarms / indications provided should be submitted by the Vendor. Vendor to specify	
3.4	All the pipes, cables etc. should be well supported and protected. Vendor to Confirm	
3.5	All the rotating parts should be statically & dynamically balanced to avoid undue vibrations and suitably guarded. Vendor to Confirm	
3.6	3 emergency switches to be provided to switch off the whole furnace for safety purpose. The locations are 1. In control Panel 2. Either side of the furnace. Vendor to Confirm	

Sl.No.	DESCRIPTION	BIDDER'S OFFER [with technical details]
3.7	6 Nos Gas leak detector to be provided to cover critical gas leak zone. The system should have independent control with alarm. Alarm should be clearly visible in the furnace control room. Vendor to provide the test certificate with LPG (Propane+Butane)/Propane sample for LEL as per standard. Functional test with same sample to be done after commissioning of the instruments at site. Supply of standard sample gas is under vendor's scope. Ambetronics /Oldham makes gas leak detectors or any other make acceptable to BHEL is preferred. Vendor to Specify	
<b>4.0</b>	<b>INSTRUMENTATION &amp; CONTROL SYSTEM:</b>	
4.1	All controls will be located in a Control Room adjacent to the furnace. BHEL will construct the Control room based on inputs to be provided by the vendor. Vendor to Confirm	
4.2	Furnace temperature control (4 Zones) Auto/Manual with PID tuning through zonal temperature controllers/burner sequence control Or Pulse-firing control. Preferred Makes. Yokogawa, Eurotherm and Chino. Vendor to Confirm	
4.3	Furnace over temperature control (4 Zones) to be made available at control panel only. Vendor to Confirm	
4.4	Vendor to offer temperature control for individual zones with inbuilt error message indication type burner sequential controller for individual burners. (Complete details should be provided along with the offer). Vendor to Confirm	
4.5	Recuparator protection for preheat temperature control. Vendor to Confirm	
4.6	The system shall comprise, but not be limited to the following:	
4.6.1	Zonal Thermocouples: 2 Nos. of Duplex thermocouples to be provided for each zone. One thermocouple for temperature controller, second for excess temperature controller 3rd for recorder and 4th as a spare. Thermocouple type-k with protective sheath to be of Inconel with adjustable flange 1 metre long. Asbestos compensating cables to be provided for heat resisting. Vendor to Confirm	
4.6.2	Suitable rated modulating motors / Control elements for 4 Zones. Vendor to Confirm	
4.6.3	Mass flow-based and Pulse firing-based zonal control system for temperature control to be offered. This has been indicated in 2.4.10	

Continuous Discharge Roller Hearth Furnace

Sl.No.	DESCRIPTION	BIDDER'S OFFER [with technical details]
4.6.4	Minimum 6 Point Micro Processor based temperature recorder with chart width 180 mm along with 50 nos. Of chart paper packs. Preferred Makes. Yokogawa, Eurotherm and Chino. Vendor to Specify.	
4.6.5	Pressure switches with isolation valves, flow transmitters with manifold valves for gas, air and control elements with suitable markings for easy observation of position of the valves to be provided. Vendor to Confirm	
4.6.6	Furnace pressure transmitters and control elements with P&I diagram should be submitted. Vendor to Confirm	
4.6.7	Instrument impulse lines and transmitter to be properly supported in the furnace.	
4.6.8	Instruments cables and compensating cables are to be separated from power cables. All cables should be of Fire Retardant Low Smoke design only. Vendor to Confirm	
4.6.9	Piping lines for instruments to be provided with clamps and neatly routed. Vendor to Confirm	
4.6.10	Metal Junction boxes with suitable terminal blocks and glands to be provided. All the wires should be with marked ferrules for easy identification both in the control panel and for the field instruments. Vendor to Confirm	
4.6.11	Suitable rating UPS with battery to be provided for the Instrument panel and recorder with a minimum backup of 1 hour. Makes: Emerson/APC/Microtek or any other make acceptable to BHEL. Vendor to specify	
4.7	Possibility of over viewing the status in the control room. Vendor to Confirm	
4.8	For excess temperature control of respective zone, it should be possible to set the limit value of each zone in the Control panel. In case of zonal temperature overshoots the maximum set value; it should control all safety systems along with raising audio visual alarm. Vendor to Confirm	
4.9	Other features required:	
	a) Alarm annunciation. Vendor to Confirm	
	b) Gas flow measuring system: Orifice type volumetric flow measurement with totalizer to be indicated in the control panel. Vendor to Confirm	
	c) Safety system and alarm indication required are to be indicated. Vendor to Confirm	

Continuous Discharge Roller Hearth Furnace

Sl.No.	DESCRIPTION	BIDDER'S OFFER [with technical details]
4.10	Separate panel should be provided for instruments, Burner sequence controller. Separate Control transformer (415V/230V) should be provided for the Instrumentation panel. Vendor to Confirm	
4.11	PI Diagram, schematic circuit diagram for instruments control system to be submitted along with offer. Vendor to Confirm	
4.12	Required Motor Control Centers shall be provided for control of all fans and blowers (This point should be separated from instrumentation and control) Vendor to Confirm	
4.13	Gas Train System details to be given for all the components with P and I diagram. Suitable pressure gauge with isolation valve to be provided in the inlet and outlet of the gas train system. An additional pressure gauge in the gas train system after the main safety valve will be provided. All the field instruments in the gas line should be of flame proof enclosure. Vendor to Confirm	
4.14	Burner purge cycles with adequate purging time for safe operation shall be provided. Vendor to Confirm	
4.15	Manual Gas Shut Off Valve shall be provided apart from the safety shutoff valve in the gas train. Vendor to Confirm	
4.16	Push button Control Station shall be provided near the furnace for all manual operations (door movement, locking and roller movement). Vendor to Confirm	
4.17	Local emergency push button stations shall also be provided for roller conveyors, fans and door drives. Vendor to Confirm	
4.18	Maintenance platform at suitable height for instrumentation to be provided. Vendor to Confirm	
4.19	Instruments Calibration: Calibration certificates to be provided for process values measuring instruments, Transmitters, Thermocouples and compensating cables. Test certificates required for Pressure switches and modulating motors etc. are to be provided at the time of inspection of the furnace at vendor works. Vendor has to carry out re-calibration for all the above calibrated items at BHEL site during commissioning. After placement of order vendor has to provide the Calibration certificate and test certificate as per BHEL format. Vendor to Confirm	

Continuous Discharge Roller Hearth Furnace

Sl.No.	DESCRIPTION	BIDDER'S OFFER [with technical details]
4.20	<p>Ignition &amp; Flame Supervision:</p> <p>Spark ignitor of high voltage type (H.V) to be used. The flame monitoring system to be with U.V. scanner or Ionisation rod for its reliability. In case of U.V Scanner, it must be provided with suitable air cooling. The flame supervision circuit is linked to the gas solenoid valve for each burner. This enables to monitor and control the flame of each burner continuously through furnace sequence controller. Vendor to confirm</p>	
5.0	LEVELING & ANCHORING SYSTEM	
5.1	Complete anchoring system including foundation bolts, anchoring materials, leveling shoes etc should be supplied by the vendor. Vendor to confirm	
6.0	TOOLS FOR ERECTION, OPERATION & MAINTENANCE:	
6.1	The Vendor shall bring special tools required for erection of the machine. Necessary tools like Torque Wrench, Spanners, Keys, grease guns etc. for operation and maintenance of the machine should be supplied. List of such tools should be submitted with offer. EOT crane service inside the shop floor for erection will be provided by BHEL. Any Mobile crane arrangements for erection of furnace and its other components are under supplier's scope. Vendor to confirm	
7.0	SPARES:	
7.1	Itemized breakup of mechanical, refractory, electrical, electronic and instrumentation spares used on the furnace in sufficient quantity as per recommendation of Vendor for 2 years of trouble free operation on three shifts continuous running basis should be offered by vendor. (Unit Price of each item of spare should be quoted). Vendor to confirm	
7.2	<p>Following spares to be quoted compulsorily</p> <ul style="list-style-type: none"> <li>a. Burner -- 20% of total quantity</li> <li>b. Burner Blocks -- 20% of total quantity</li> <li>c. Burner Controllers --20% of total quantity</li> <li>d. Gas Solenoid Valve for burners-- 20% of total quantity</li> <li>e. UV Flame Detector/Ionization sensor--20% of total quantity</li> <li>f. Thermocouple-duplex -- 4 Nos.</li> <li>g. Flow transmitter for gas: 1 No.</li> <li>h. Flow transmitter for air: 1 No.</li> </ul>	

Continuous Discharge Roller Hearth Furnace

Sl.No.	DESCRIPTION	BIDDER'S OFFER [with technical details]
	<p>i. Pressure switch for gas: 1 No.  j. Pressure switch for air: 1 No.  k. Furnace Pressure transmitter: 1 No.  l. Actuator for gas: 2 No.  m. Actuator for air : 2 No  n. Push Buttons : 1 Set  o. Relays : 1 Set  p. Contactors :1 Set  q. All types of Fuses :1 set  r. Controller : 1 No  s. Indication lamp : 1 Set  t. Limit switches: 4 Nos.  u. Ribbon cartridge: 3 Nos.  v. Excess temp controller: 1no.  w. All type of Air valves: 10% of quantity in each type used in the furnace  x. All type of Castings: 10% of quantity in each type used in the furnace  y. All type of Gas valves: 10% of quantity used in the furnace  z. All types of refractory bricks (Standard bricks and special shaped bricks): 10% of quantity each used in the furnace  aa. All types of ceramic fiber modules and blankets used in the furnace: 10% of quantity in each type(max. temp and density) used in the furnace  bb. Plummer block with bearing of each type used in the furnace – 1set.  cc. Gas filter – 1 no  dd. Gas filter element – 5 no's  ee. GVT line Pressure Regulator – 1 no  ff. Gas leak detector – 1 no</p> <p>Vendor to Quote.</p>	

Sl.No.	DESCRIPTION	BIDDER'S OFFER [with technical details]
7.3	Vendor to confirm that complete list of spares for machine and accessories, along with item part no / specification /type / model, and name & address of the spare supplier shall be furnished along with documentation to be supplied with the machine.	
<b>8.0</b>	<b>DOCUMENTATION</b>	
<b>8.1</b>	Documents to be submitted along with offer for technical Evaluation:	
<b>8.1.1</b>	<p><b>The vendor to submit the following drawings / details along with offer for technical evaluation:</b></p> <ol style="list-style-type: none"> <li>1. P&amp;I Diagram with bill of materials</li> <li>2. General Arrangement diagram</li> <li>3. Schematic Instrument circuit diagram</li> <li>4. Electrical circuit diagram (power and control circuit) with detailed BOM</li> <li>5. Electrical component layout drawings of all control panels and operator pendants.</li> <li>6. Heat load calculation</li> <li>7. Furnace efficiency calculation</li> <li>8. Complete list of components in Each Burner Assembly</li> <li>9. Burner capacity selection method</li> <li>10. Burner arrangement layout drawing.</li> <li>11. Drive arrangement drawings for Roller drive &amp; door drive with bill of materials.</li> <li>12. Counterbalance &amp; door locking arrangement drawing</li> <li>13. FD &amp; ID Fan calculation</li> <li>14. Refractory arrangement with Bill of materials</li> <li>15. Casting arrangements.</li> <li>16. Recuperator selection and heat transfer calculation.</li> <li>17. Piping routing diagram</li> <li>18. Quality action plan</li> <li>19. MSDS for all insulation and refractory items used in the furnace.</li> <li>20. Panel layout</li> </ol> <p>Vendor to enclose</p>	

Sl.No.	DESCRIPTION	BIDDER'S OFFER [with technical details]
8.2	<b>Documents to be submitted for BHEL approval before manufacturing:</b>	
8.2.1	<p>The vendor to submit the following drawings / details for BHEL approval before manufacturing (drawing should be submitted for approval within one month of ordering date and approval of drawings should be obtained by vendor within 30 days from the date of submission of drawings to BHEL for approval by providing required details/clarifications to BHEL if any):</p> <ol style="list-style-type: none"> <li>1) P&amp;I Diagram with bill of materials</li> <li>2) General Arrangement diagram</li> <li>3) Schematic Instrument circuit diagram</li> <li>4) Electrical circuit diagram (power and control circuit) with detailed BOM</li> <li>5) Electrical component layout drawings of all control panels and operator consoles</li> <li>6) Heat load calculation</li> <li>7) Furnace efficiency calculation</li> <li>8) Skin temperature calculation</li> <li>9) Complete list of components in Each Burner Assembly</li> <li>10) Burner capacity selection method</li> <li>11) Burner arrangement layout drawing.</li> <li>12) Drive arrangement drawing for Roller drive &amp; door drive with bill of materials</li> <li>13) Counterbalance &amp; door locking arrangement drawing</li> <li>14) FD &amp; ID Fan calculation</li> <li>15) Refractory arrangement with Bill of materials and special shaped brick drawings</li> <li>16) Casting arrangements and casting drawings.</li> <li>17) Panel layout</li> <li>18) Quality plan.</li> <li>19) Recuperator selection and heat transfer calculation</li> <li>20) Piping Routing Diagram</li> <li>21) MSDS for all insulation and refractory items used in the furnace</li> </ol> <p>Vendor to confirm</p>	

Continuous Discharge Roller Hearth Furnace

Sl.No.	DESCRIPTION	BIDDER'S OFFER [with technical details]
8.3	<b>Documents to be submitted along with Equipment:</b>	
8.3.1	Three sets of O&M manuals (3 Hard copies) in English language having the following documents should be supplied along with the furnace. Apart from the hard copies, vendor to provide the entire documentation in a single PDF including the catalogues of all bought items and the same shall be provided in a pen drive.	
8.3.2	The O&M Manual should contain the following. <b>Vendor to confirm</b>	
A	One copy of ALL approved drawings	
B	P&I Drawing of furnace	
C	Electrical Wiring Drawings – Power & Control Circuits	
D	Terminal drawings with check points shall be provided for Electronic Controls	
E	Trouble Shooting Chart for Main and all Sub-Systems	
F	Specifications, Catalogues, O&M Manuals and Engineering manuals of all bought out items including drawings, wherever applicable.	
G	All Mechanical drawings for the items manufactured / covered under scope of vendor. Mechanical drawing includes GA & Sub-assembly drawings with major and critical dimensions, material and weight.	
H	Furnace Operation Procedure for startup, purging, shutdown, Power failure interruption, Gas fluctuation condition, etc. with all safety instructions.	
I	Complete refractory lay out and shaped brick drawings with dimensions, including specification of refractory materials used.	
J	Complete Casting lay out and individual casting drawings with dimensions, including specification of casting materials used.	
K	Drive arrangement drawings for Roller drive & door drive with bill of materials including specification of materials used.	
L	Counterbalance and door locking arrangement drawings for door with bill of materials including specification of materials used.	
M	Doors sealing/locking arrangement drawings.	
N	Complete details of Combustion system- Operation and maintenance.	

Sl.No.	DESCRIPTION	BIDDER'S OFFER [with technical details]
<b>O</b>	Complete Master List of spare parts used along with item part number/ specification/ type, name and address of the spare supplier	
<b>P</b>	Calibration certificates for all the Panel instruments, Transmitters, Flow meters, Thermocouples and test certificates for Pressure switches, modulating motors and regulators.	
<b>Q</b>	Complete Printed Circuit Board Schematics indicating check points (Test Points) for Electronic Controls.	
<b>R</b>	Complete calculations for heat load, skin temperature, burner selection, FD fan selection, refractory selection, efficiency, fuel consumption, etc.	
<b>S</b>	Panel layout with details for panel size, Painting, Cable entry, etc. Details and specification for contactor, MCB, Push buttons, OLR, Indication lamps, ON/OFF rotary switches, Isolators, selector switches, safety devices, etc to be provided.	
<b>T</b>	List of all alarms / indications / annunciator.	
<b>U</b>	The vendor shall submit complete Master List of parts used in the machine.	
<b>V</b>	Dimensional Sketches (plan, front and side view) of the entire panel and detailed view of position and layout of controls, display and other man machine interface will be submitted for ergonomics	
<b>W</b>	Furnace control schematic	
<b>X</b>	Engineering manual for the controller	
8.4	One set of all the documents (hard copy and soft copy) to be shown to the BHEL inspector at the time of inspection at vendor's works. Vendor to confirm	
<b>9.0</b>	<b>TRAINING:</b>	
9.1	The Vendor shall impart training to BHEL's Operators & Maintenance crew in Operation & Maintenance (Mechanical, Electrical & Control System) after the commissioning, at BHEL for 15 working days. Vendor to confirm	
<b>10.0</b>	<b>FOUNDATION:</b>	
10.1	Vendor shall submit the preliminary layout drawing for getting BHEL's approval within one month from the date of ordering. The layout should consist of all requirements pertaining to complete furnace including space requirement for Control Room, Blowers, and Stack etc. Vendor shall furnish the foundation layout and static and dynamic load details within 3 months of Purchase order. BHEL shall design and construct complete foundation for the furnace as per the Vendor's recommendation. Vendor to confirm	

Continuous Discharge Roller Hearth Furnace

Sl.No.	DESCRIPTION	BIDDER'S OFFER [with technical details]
11.0	<b>ERECTION &amp; COMMISSIONING</b>	
11.1	Vendor to take full responsibility for carrying out the erection, start up, testing and commissioning of the furnace & it's controls & all types of other supplied equipment. The vendor shall arrange required manpower & tools for the same. Vendor to confirm	
11.2	Service requirement like power, air & water shall be provided by BHEL at only one point to be indicated by Vendor in their foundation/layout drawings free of cost. Fabrication requirements like gas, three phase welding machine, welding electrodes and mobile crane at site are in the scope of vendor. Welding electrode used for Mild Steel should be of 7018 grade and for other alloy materials & pipeline welding suitable grade electrodes acceptable to BHEL should be used. Vendor to confirm	
11.3	Successful proving of BHEL components by the Vendor shall be considered as part of commissioning. All tests, as mentioned in clause 12.0 (Furnace Inspection & acceptance) shall form part of the commissioning activity.	
11.4	The Vendor should bring tools, Tackles, gas cutting and welding equipments and other necessary equipment required to carry out all above activities.	
11.5	Vendor shall bring commissioning spares required for commissioning of the machine on returnable basis within stipulated time	
11.6	Schedule of E & C shall be submitted with the offer.	
11.7	Vendor should furnish charges, duration, terms & conditions for E&C in detail separately along with offer.	
<b>12.0</b>	<b>FURNACE INSPECTION &amp; ACCEPTANCE</b>	
12.1	<b>Inspection at Vendor's works:</b> The furnace materials and bought-out items shall be offered for inspection to BHEL for completeness of supply at supplier's works prior to dispatch. Vendor to Confirm	
12.1.1	Complete sub-systems as per the contract-Verification of functions to the extent possible	
12.1.2	Blowers (FD & ID fans) to be offered for checking the performance. If required it shall be offered at supplier's works.	
12.1.3	Verification of Calibration certificates of instruments	
12.1.4	Verification of documents as per clause (8.4)	

Sl.No.	DESCRIPTION	BIDDER'S OFFER [with technical details]									
12.2	<p><b>Inspection at BHEL works:</b>                      The furnace shall be tested by the vendor for its performance prove-out as per BHEL Specifications, at BHEL after erection and Commissioning                      Furnace calibration to be tested and proved by vendor for the jobs &amp; Stress relieving cycles given by BHEL at the time of job prove out.                      Stress relieving cycles:</p> <table border="1" data-bbox="831 460 1347 697"> <thead> <tr> <th data-bbox="831 460 1145 519">Soaking Temp for various materials</th> <th data-bbox="1145 460 1347 519">Soaking time</th> </tr> </thead> <tbody> <tr> <td data-bbox="831 519 1145 550">610 +/- 15 deg.C</td> <td data-bbox="1145 519 1347 697" rowspan="6">60 Minutes maximum.</td> </tr> <tr> <td data-bbox="831 550 1145 581">635 +/- 15 deg.C</td> </tr> <tr> <td data-bbox="831 581 1145 613">655 +/- 15 deg.C</td> </tr> <tr> <td data-bbox="831 613 1145 644">695 +/- 15 deg.C</td> </tr> <tr> <td data-bbox="831 644 1145 675">730 +/- 10 deg.C</td> </tr> <tr> <td data-bbox="831 675 1145 697">745 +/- 15 deg.C</td> </tr> </tbody> </table> <p>The heat treatment charts have to be approved by BHEL.</p>	Soaking Temp for various materials	Soaking time	610 +/- 15 deg.C	60 Minutes maximum.	635 +/- 15 deg.C	655 +/- 15 deg.C	695 +/- 15 deg.C	730 +/- 10 deg.C	745 +/- 15 deg.C	
Soaking Temp for various materials	Soaking time										
610 +/- 15 deg.C	60 Minutes maximum.										
635 +/- 15 deg.C											
655 +/- 15 deg.C											
695 +/- 15 deg.C											
730 +/- 10 deg.C											
745 +/- 15 deg.C											
12.2.1	Verification of Calibration certificates of instruments.										
12.2.2	Verification of Control logic for all functions by simulation.										
12.2.3	Verification of Pollution control norms, skin temperature, etc.										
12.2.4	Verification of Documents as per clause <b>(8.3.2)</b>										
13.0	<b>PAINTING:</b>										
13.1	For Furnace, Recuperator & Stack. Vendor to Confirm										
13.1.1	Primer painting: One coat of primer painting at vendor's works and one coat of primer after erection. Vendor to Confirm										
13.1.2	Final painting: Vendor to paint the complete furnace chamber with 2 coats of heat resistant Al paint (of grade 250 deg C) and the entire chimney, recuperator & flue path with 2 coats of heat resistant Al paint (of grade 400 deg C). All new fabricated items to be painted after one coating of primer paint. Vendor to Confirm										
13.2	For Fans & control Panel: Two coats of IS 281 Synthetic Enamel Apple Green Color Paint. Vendor to confirm										
13.3	Air & Gas Pipelines: Two coats of Blue & Yellow color synthetic enamel paint or as per instructions of BHEL and with indication of direction of flow marked at suitable intervals. Vendor to confirm										

Continuous Discharge Roller Hearth Furnace

Sl.No.	DESCRIPTION		BIDDER'S OFFER [with technical details]
13.4	Any painting rubbed off / peeled off during transit or erection should be repainted and merged with the original paint by the vendor.		
<b>14.0</b>	<b>PACKING:</b>		
14.1	Rigid packing for items like fans, blowers, drives, electric / electronic panels and controls and such other items susceptible to damage during transit. Vendor to confirm		
<b>15.0</b>	<b>GUARANTEE:</b>		
15.1	The complete furnace with accessories and all systems shall be guaranteed for a period of 12 months from commissioning or 18 months from date of dispatch whichever is earlier. Vendor to confirm		
<b>16.0</b>	<b>GENERAL:</b>		
	a) Furnace Model No.- Vendor to specify		
	b) Total connected load (KVA): Vendor to specify		
	c) Approximate Floor area required (Length x Width) and Height for complete Furnace & accessories. Vendor to specify		
	d) Total weight of the furnace. Vendor to specify		
17.0	Scope of Supply		
17.1	Supplier Scope	<ol style="list-style-type: none"> <li>1. Design, Manufacture, Supply, Erection, Commissioning and prove out of LPG(Propane+Butane)/Propane Fired Continuous discharge roller hearth furnace including roller conveyor system.</li> <li>2. All anchoring &amp; foundation bolts, levelling plates for the complete furnace and its accessories and chimney</li> <li>3. Levelling Instruments, Power Tools / Hand Tools for erection.</li> <li>4. Mobile Crane / Winches for erection and other peripherals where there is no reach of shop EOT crane.</li> <li>5. Welding machines and consumables required for erection</li> <li>6. Commissioning Engineer with erection crew</li> <li>7. Furnace calibration and Heat treatment cycles prove out</li> </ol> <p>Vendor to confirm</p>	

Continuous Discharge Roller Hearth Furnace

Sl.No.	DESCRIPTION		BIDDER'S OFFER [with technical details]
17.2	BHEL Scope	<ol style="list-style-type: none"> <li>1. Drawings approval</li> <li>2. Civil foundation work as per manufacturer's drawing</li> <li>3. Jobs for prove out</li> <li>4. EOT Crane inside shop</li> <li>5. Compressed air supply and LPG(Propane+Butane)/Propane supply at one location as indicated in the drawing</li> <li>6. Electrical Power Supply point at one location as indicated in the drawing</li> </ol> <p>Vendor to confirm.</p>	

CAUTION: THE DRAWING IS OUR SOLE PROPERTY AND SHOULD NOT BE USED IN ANY FORM FOR ANY PURPOSE WITHOUT THE WRITTEN PERMISSION OF BHARAT HEAVY ELECTRICALS LIMITED, PICHAMPALLY - 500 011.

ALL DIMENSIONS ARE IN MM

#62.5h6	-0.000	#65k6	+0.021	18P9	+0.030
#65h6	-0.019		+0.002		+0.000

3.2/1.6/0.8

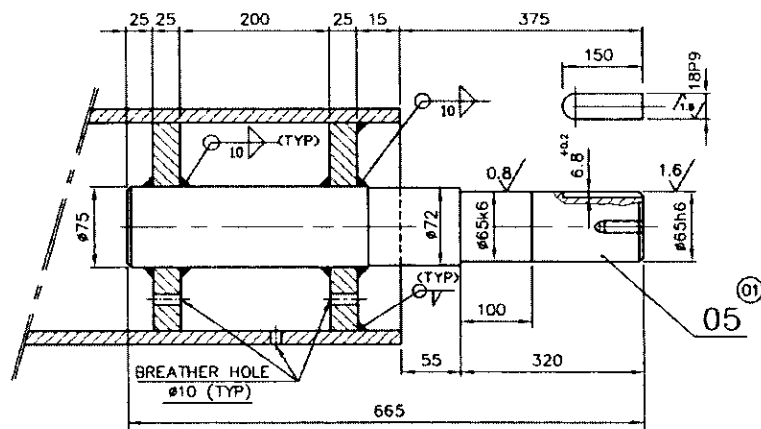
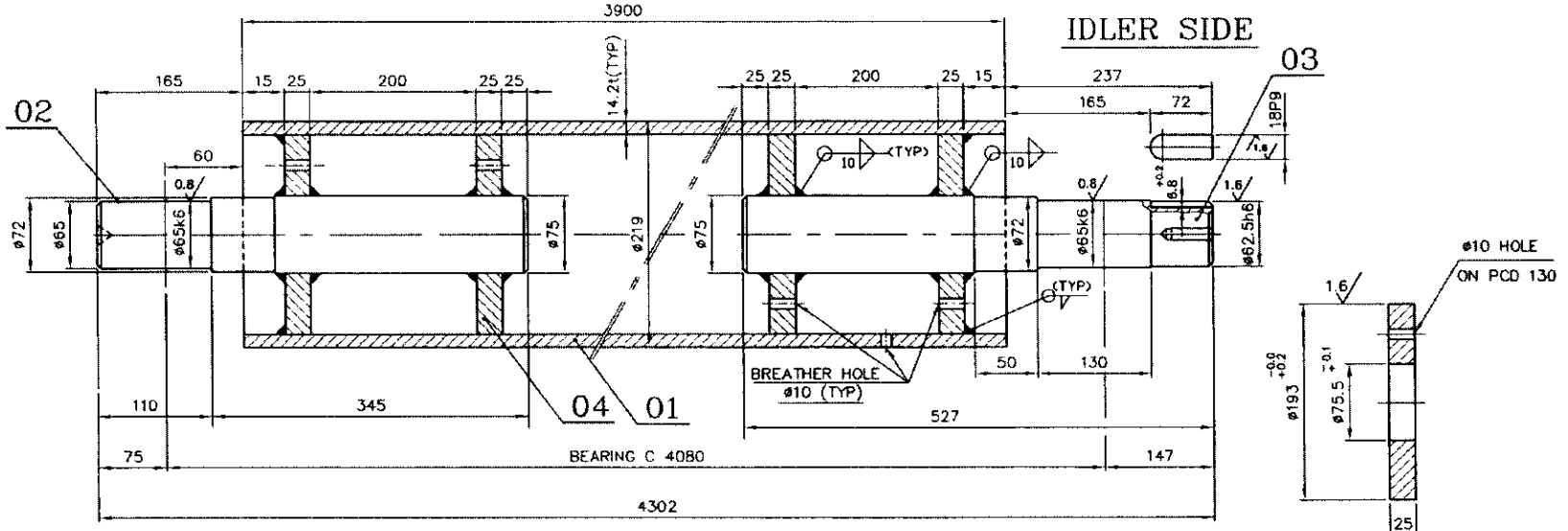

NOTE:-  
ALL WELDED CONSTRUCTIONS

ITEM No.04

01	STUB AXLE #75x665 L	45 CB	IS: 7283	23.06		05
04	PL.25xID.75xOD.190.6	Fe: 410 WB	IS: 2062	22.96		04
01	STUB AXLE #75x527 L	45 CB	IS: 7283	18.27		03
01	STUB AXLE #75x455 L	45 CB	IS: 7283	15.77		02
01	PIPE#219x14.2x...3900L	SA.106 Gr.B	ASME	279.82		01
				359.88		
DESCRIPTION		MATERIAL	STANDARD	NET.WT.IN KGS.	DRAWING No.	ITEM No.
REFERENCE: 4793/03/11		ALTERATIONS:		DCN REF	DATE	SIGN.
		ITEM No.05 ADDED			23/07/09	CSJ
SCALE	DRAWN	P.A.ROSS				
N.T.S.	CHECKED					
	APPROVED					
	DATE	08-07-08				
MACHINE: CONTINUOUS DISCHARGE FURNACE				TYPE: PRECISION CONTROLS-CDF		REV:
TITLE: CHARGE TABLE & DISCHARGE TABLE ROLLER ASSY.				DRAWING No.		
				3M18B101358401		
Sheet No				No. of Sheets		

