

# **3 X 660 MW NORTH KARANPURA STPP**

***VOLUME – IIB***

***TECHNICAL SPECIFICATION FOR  
PUBLIC ADDRESS SYSTEM***

***BHEL DOCUMENT NO. : PE-TS-405-557-E001, REV-00***



**BHARAT HEAVY ELECTRICALS LIMITED  
POWER SECTOR  
PROJECT ENGINEERING MANAGEMENT  
NOIDA – 201301**

	3 X 660 MW NORTH KARANPURA STPP	Doc. No PE-TS-405-557-E001
		Volume: IIB
	TECHNICAL SPECIFICATION FOR PUBLIC ADDRESS SYSTEM	Section
		Rev. : 00 Page : 1 of 1

**CONTENTS**

S.NO.	CONTENT	PAGE NO.
<b><u>VOLUME II B:</u></b>		
1.	<b>INSTRUCTIONS TO BIDDERS FOR PREPARING TECHNICAL OFFERS</b>	<b>1</b>
2.	<b>PREAMBLE</b>	<b>2</b>
3.	<b>SECTION-A</b> SCOPE OF SUPPLY	<b>1</b>
4.	<b>SECTION-B</b>  PROJECT INFORMATION	  <b>7</b>
5.	<b>SECTION-C</b>  SPECIFIC TECHNICAL REQUIREMENTS	  <b>9</b>
	ANNEXURE 1- ZONE WISE DISTRIBUTION OF HANDSET STATIONS & PLOT PLAN	<b>5</b>
	ANNEXURE 2- BILL OF QUANTITY	<b>5</b>
	ANNEXURE 3- PA SYSTEM DRAWINGS & DOCUMENTS	<b>1</b>
	ANNEXURE 4-LIST OF DRAWINGS/ DOCUMENTS DISTRIBUTION	<b>1</b>
	ANNEXURE 5- QUALITY PLAN	<b>7</b>
	ANNEXURE 6- LIST OF TYPE TEST FOR PUBLIC ADDRESS SYSTEM	<b>1</b>
6.	<b>SECTION-D</b>  STANDARD SPECIFICATION OF PUBLIC ADDRESS SYSTEM	  <b>26</b>
	DATA SHEET-A	<b>4</b>
	DATA SHEET-C	<b>6</b>
	<b>TOTAL NO. OF SHEETS (INCLUDING COVER SHEET,CONTENT SHEET &amp; SEPARATOR SHEETS)</b>	<b>= 87</b>

IT IS CONFIRMED THAT OUR TECHNICAL OFFER COMPLIES WITH THE SPECIFICATION IN TOTAL & THAT THERE ARE NO TECHNICAL DEVIATIONS.

-----  
BIDDER'S STAMP & SIGNATURE

# **VOLUME – II B**

	3 X 660 MW NORTH KARANPURA STPP	Doc. No. PE-TS-405-557-E001	
		Volume	Section
	TECHNICAL SPECIFICATION FOR PUBLIC ADDRESS SYSTEM	IIB	
		Rev. : A	
		Page : 1 of 1	

### **INSTRUCTIONS TO BIDDERS FOR PREPARING TECHNICAL OFFERS**

1. Two signed and stamped copies of the following shall be furnished by all bidders as technical offer :
  - a. Unpriced Price Schedule (Annexure-2A,2B,2C,2D & 2E) with bidder's signature and company stamp.
  - b. A copy of this sheet ("Instructions to Bidders for Preparing Technical Offer"), with bidder's signature and company stamp.
  - c. A copy of previous sheet ("List of Contents"), with bidder's signature and company stamp.
2. No technical submittal such as copies of type test certificates, data Sheets, write-up, drawing, technical literature, etc. is required during tender stage. Any such submission, even if made, shall not be considered as part of offer.
3. Confirmations/ comments (if any) regarding delivery schedules shall be furnished as part of the commercial offer. Any reference elsewhere/ covering letter of technical offer shall not be considered by BHEL.
4. Any comments/ clarifications on technical/ inspection requirements furnished as part of bidder's covering letter shall not be considered by BHEL, and bidder's offer shall be construed to be in conformance with the specification.
5. Any changes made by the bidder in the price schedule with respect to the item description/ quantities, notes etc. from those given in Annexure-2 of specification [Bill Of Quantities] shall not be considered (i.e., technical description, quantities, notes etc. as per specification shall prevail).

-----  
BIDDER'S STAMP & SIGNATURE

---



3 X 660 MW NORTH KARANPURA STPP

TECHNICAL SPECIFICATION FOR PUBLIC  
ADDRESS SYSTEM

Doc. No

PE-TS-405-557-E001

Volume: IIB

Section

Rev. : 00

Page : 1 of 2

### PREAMBLE

1.0 The Tender documents contain two (2) volumes. The bidder shall meet the requirements of all the volumes.

#### 1.1 VOLUME - I CONDITIONS OF CONTRACT

This consists of four parts as below:-

**Volume – IA** This part contains Instructions to bidders for making bids to BHEL.

**Volume – IB** This part contains General Commercial Conditions of the Tender & includes provision that vender shall be responsible for the quality of item supplied by their sub-vendors.

**Volume – IC** This part contains Special Conditions of Contract.

**Volume – ID** This part contains Commercial conditions for Erection & Commissioning site work, as applicable.

#### 1.2 VOLUME – II TECHNICAL SPECIFICATIONS

Technical requirements are stipulated in Volume – II, which comprises of:-

**Volume – IIA** General Technical Conditions.

**Volume – IIB** Technical Specification including Drawings, if any.

##### 1.2.1 VOLUME – IIB

This volume is sub-divided in to following sections:-

**Section – A** This section outlines the Intent of Specification

**Section – B** This section provides “Projection Information”.

**Section – C** This section indicates Technical Requirements specific to Contract, not covered in Section - D

**Section – D** This section comprises of Technical Specifications of Equipments Complete with Data Sheets A , B , C.

	<b>3 X 660 MW NORTH KARANPURA STPP</b>	Doc. No PE-TS-405-557-E001
		Volume: IIB
<b>TECHNICAL SPECIFICATION FOR PUBLIC ADDRESS SYSTEM</b>		Section
		Rev. : 00
		Page : 1 of 2

**Data sheet - A :-** Specific data and other requirements pertaining to the equipments.

**Data sheet – B :-** Indicates data / documents to be furnished at the time of submission of Offer by vendor

**Data sheet – C :-** Indicates data / documents to be furnished after the award of Contract as per agreed schedule by the vendor (as applicable)

***SECTION – A***

**SCOPE OF SUPPLY**

	<b>3 X 660 MW NORTH KARANPURA STPP</b>	Doc. No PE-TS-405-557-E001
		Volume: IIB
<b>TECHNICAL SPECIFICATION FOR PUBLIC ADDRESS SYSTEM</b>		Section :A
		Rev. : 00
		Page : 1 of 1

### SCOPE OF SUPPLY

1. This specification covers the design, manufacture, inspection and testing at manufacturer's works, proper packing and delivery to site, system engineering, testing, erection and commissioning of PUBLIC ADDRESS SYSTEM as mentioned in different sections of this specification for 3 X 660 MW NORTH KARANPURA STPP.
2. It is not the intent to specify herein all the details of design & manufacture. However, the equipment shall conform in all respects to high standards of design, engineering and workmanship and shall be capable of performing in continuous commercial operation.
3. The general terms and conditions, instructions to bidders and other attachment referred to elsewhere are hereby made part of the Technical Specification.
4. The bidders shall be responsible for and governed by all requirements stipulated hereinafter.
5. The documents shall be in English language and MKS system of units.
6. Bidder shall quote for all type of PA system items as per specification, failing which their offer shall be rejected.
7. For every shipment made to site, a shipping list containing item reference (item no. & description as per specification Bill of material of package drawing) and quantity of the same (nos.) shall be provided by the vendor at the time of dispatch of material to site.

***SECTION – B***

**PROJECT INFORMATION**



CLAUSE NO.	PROJECT INFORMATION			
1.04.02	<p>Cabinet Committee on Investment (GOI) in its meeting on 20.02.13 decided in-principle to restore the original coal linkage granted to NKSTPP (i.e. from Magadh Coal Block) with the stipulation that the coal supply will commence during the 13th Five Year Plan. MOC vide letter dated 09.05.2013 restored the coal linkage with the stipulation that the coal supply will commence during the 13<sup>th</sup> five year plan.</p> <p><b>Coal Transportation</b></p> <p>Coal from Magadh block of North Karanpura Coalfields is proposed to be transported to the project site through conveyor belt system. One external coal handling plant and one internal coal handling plant are envisaged.</p>			
1.05.00	<p><b>Meteorological Data</b></p> <p>Important meteorological data from nearest observatory at Hazaribag is placed at Annexure-II.</p>			
1.06.00	<p><b>Plant Water Scheme</b></p> <p>The Plant water scheme is described below.</p>			
1.06.01	<p><b>Condenser Cooling System</b></p> <p>It is proposed to adopt Air Cooled Condenser for the project.</p>			
1.06.02	<p><b>Equipment Cooling Water (ECW) System (Unit Auxiliaries)</b></p> <p>All plant auxiliaries shall be cooled by De-mineralized water (DM) in a closed circuit. The primary circuit DM water shall be cooled through heat exchangers by auxiliary cooling water system. The hot secondary circuit cooling water shall be cooled in the cooling towers and shall be returned back to the system.</p>			
1.06.03	<p><b>Ash Water System</b></p> <p>It is proposed to have HCSD (High concentration Slurry Disposal) system for combined fly ash and bottom ash. No recirculation of ash water from ash disposal area is envisaged.</p>			
1.06.04	<p><b>Other Miscellaneous Water Systems</b></p> <p>(a) Raw water shall be used for meeting the Fly ash and bottom ash system requirement etc.</p> <p>(b) The service water shall be taken from clarified water tank of Pretreatment plant. Service water (wash water) collected from various areas shall be treated using oil water separators, tube settlers, coal settling pits etc. as per requirement and treated water from liquid effluent treatment plant shall be recycled back to the service water system for re-use.</p> <p>(c) The drinking water requirement of the plant shall be provided from water treatment plant.</p>			
<p><b>NORTH KARANPURA STPP (3 X 660 MW) EPC PACKAGE</b></p>		<p><b>TECHNICAL SPECIFICATION SECTION – VI, PART-A BID DOC. NO.:CS-4410-001-2</b></p>	<p><b>SUB-SECTION-IB PROJECT INFORMATION</b></p>	<p><b>PAGE 2 OF 10</b></p>

CLAUSE NO.	PROJECT INFORMATION			
1.07.00	<p>(d) Steam Cycle make-up water, makeup to the primary circuit of ECW (unit auxiliaries) system, boiler fill water and makeup to the hydrogen generation plant shall be provided from Demineralising plant.</p> <p>(e) The quality of Raw water is enclosed with this sub-section as Annexure-III.</p> <p><b>Criteria for Earthquake Resistant Design of Structures and Equipment</b></p> <p>All power plant structures and equipment, including plant auxiliary structures and equipment shall be designed for seismic forces as given in the Part - B of this section.</p>			
1.08.00	<p><b>Criteria for Wind Resistant Design of Structures and Equipment</b></p> <p>All structures and equipment of the power plant, including plant auxiliary structures and equipment, shall be designed for wind forces as given as given in Part B of this section.</p>			
<p>NORTH KARANPURA STPP (3 X 660 MW) EPC PACKAGE</p>	<p>TECHNICAL SPECIFICATION SECTION – VI, PART-A BID DOC. NO.:CS-4410-001-2</p>	<p>SUB-SECTION-IB PROJECT INFORMATION</p>	<p>PAGE 3 OF 10</p>	

VICINITY PLAN

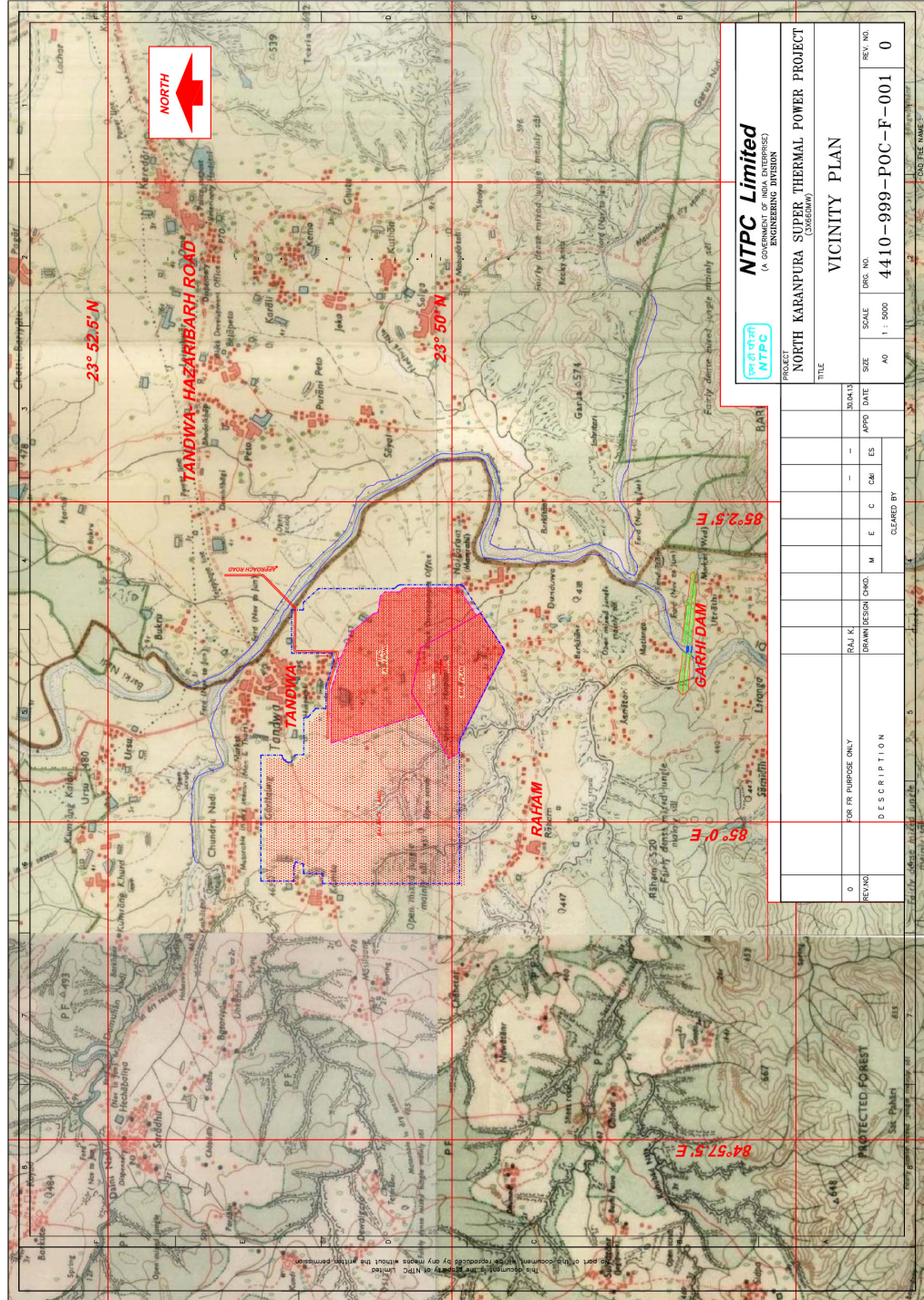

 <b>NTPC Limited</b> <small>(A COMPANY OF NTPC)</small> <small>ENGINEERING DIVISION</small>	
<b>PROJECT</b> NORTH KARANPURA SUPER THERMAL POWER PROJECT <small>(3000MW)</small>	
<b>TITLE</b> VICINITY PLAN	
NO. FOR PURPOSE ONLY	SCALE
0	1 : 5000
REVISION	DATE
DESCRIPTION	APPROVED BY
	DATE
	REV. NO.
	0



CLIMATOLOGICAL TABLE

CLIMATOLOGICAL TABLE

1951 से 1980 तक के अवधि पर आधारित  
BASED ON OBSERVATIONS FROM 1951 TO 1980

STATION : Hazaribagh  
STATION : Hazaribagh  
LAT 23°59' N LONG 85°22' E  
सही तल मध्य से ऊँचाई मीटर  
HEIGHT ABOVE M. S. L. 611 METRES

माह	वायु तापमान				वायु आर्द्रता				वायु चलाव				वायु वर्षा					
	शुष्क बल्ब ताप	तम ताप	दैनिक औसत ताप	सर्वोच्च ताप	शुष्क बल्ब ताप	तम ताप	दैनिक औसत ताप	सर्वोच्च ताप	सर्वोच्च ताप	सर्वोच्च ताप	सर्वोच्च ताप	सर्वोच्च ताप	सर्वोच्च ताप	सर्वोच्च ताप	सर्वोच्च ताप	सर्वोच्च ताप		
JAN	14.7	9.3	26.7	4.6	30.6	18.1	0.9	07	82	10.4	1.4	0.5	1.7	113.0	0.0	86.1	06	6.2
FEB	15.9	12.0	30.5	6.9	33.6	18.1	1.7	09	49	10.4	1.8	0.5	1.4	1919	0.0	66.1	1945	7.3
MAR	17.9	16.6	35.6	11.4	38.9	18.1	6.7	04	52	10.3	1.3	0.4	1.4	1907	0.0	63.5	23	7.3
APR	23.4	21.3	39.3	16.4	41.7	18.1	10.6	01	39	10.8	1.5	0.3	1.7	184.3	0.0	44.2	20	7.9
MAY	28.6	24.0	41.5	19.3	43.9	18.1	15.6	22	36	13.3	1.8	0.3	1.4	81.6	0.0	60.5	22	6.6
JUN	32.4	24.1	40.1	21.0	46.6	18.1	18.3	02	43	15.7	2.9	0.7	2.9	197.2	0.0	84.1	27	9.1
JUL	35.6	23.0	35.2	21.4	39.6	18.1	19.3	18	67	25.0	5.3	1.8	9.2	774.5	0.5	249.2	24	8.7
AUG	34.5	22.7	31.5	21.3	34.2	18.1	20.0	29	86	28.2	6.5	3.6	16.2	693.2	99.8	221.7	06	7.9
SEP	31.5	22.2	31.5	20.4	33.3	18.1	17.8	29	88	28.3	6.4	3.8	16.2	706.1	83.8	180.1	17	7.6
OCT	23.9	18.9	31.3	14.3	34.0	18.1	9.7	12	84	26.8	5.1	2.9	11.6	530.9	40.7	167.4	28	7.3
NOV	20.2	13.3	28.3	9.0	31.7	18.1	4.4	25	73	21.4	2.4	1.2	4.1	378.6	0.0	149.4	24	5.2
DEC	15.7	9.3	26.2	5.1	29.4	18.1	0.5	24	68	21.3	2.9	1.3	0.4	160.0	0.0	95.0	08	4.8
ANNUAL MEAN	23.3	18.1	41.9	3.8	46.6	18.1	0.5	05	63	16.2	3.0	1.3	67.2	2146.0	739.6	249.2	13	7.2
दैनिक औसत ताप	25.9	27	27	28	83	83	27	27	55	17.7	3.3	1.5	29	1893	1968	99	99	23
वर्षावर्षा	28	28	28	28	28	28	28	28	28	27	29	23	29	99	99	99	99	99

CLAUSE NO.	PROJECT INFORMATION																			
1.00.00	<b>General Requirements</b>																			
1.01.00	For the purpose of design of equipment/systems, an ambient temperature of 50 deg. Centigrade and relative humidity of 95% shall be considered. The equipment shall operate in a highly polluted environment. However, for equipment in air conditioned areas, design ambient temperature shall be 35 deg.C, if 2x100% air conditioning system is provided.																			
1.02.00	All equipments shall be suitable for rated frequency of 50Hz with a variation of +3% & -5%, and 10% combined variation of voltage and frequency unless specifically brought out in the specification. The step-up voltage level for the project shall be 400 KV. The turbo generator unit will be connected to its own step-up transformers for feeding power into the EHV grid. The overall system shall be designed considering voltage variation of +/- 5% and fault level of 50kA for 400KV and 40kA for 220 KV system. Under black start condition the minimum fault level of 1000 MVA shall be considered at 400KV voltage level and voltage variation at 400kV may be considered as +/-10% till system stabilization.																			
1.03.00	Contractor shall provide fully compatible electrical system, equipments, accessories and services for the entire station/plant in his scope as well as those specifically required by the Employer.																			
1.04.00	All the equipment, material and systems shall, in general, conform to the latest edition of relevant National and International Codes & Standards, especially the Indian Statutory Regulations.																			
1.05.00	<p>The auxiliary AC voltage supply arrangement shall have 33 kV, 11 kV, 3.3KV and 415V systems. It shall be designed to limit voltage variations as given below under worst operating condition:</p> <table border="0" data-bbox="344 1077 1445 1234"> <tr> <td>a)</td> <td>33KV/11KV/3.3KV (MV)</td> <td>+/- 6%</td> </tr> <tr> <td>b)</td> <td>415 V/240 V</td> <td>+/- 10%</td> </tr> <tr> <td>c)</td> <td>220V DC</td> <td>-15% to +10% However the nominal continuous DC power supply shall be 240V.</td> </tr> </table>				a)	33KV/11KV/3.3KV (MV)	+/- 6%	b)	415 V/240 V	+/- 10%	c)	220V DC	-15% to +10% However the nominal continuous DC power supply shall be 240V.							
a)	33KV/11KV/3.3KV (MV)	+/- 6%																		
b)	415 V/240 V	+/- 10%																		
c)	220V DC	-15% to +10% However the nominal continuous DC power supply shall be 240V.																		
1.06.00	<p>The voltage level for motors shall be as follows:</p> <table border="0" data-bbox="344 1312 1414 1570"> <tr> <td>a)</td> <td>Upto 0.2 KW</td> <td>:</td> <td>Single phase 240V AC / 3 phase 415V AC</td> </tr> <tr> <td>b)</td> <td>Above 0.2 KW and upto 200 KW</td> <td>:</td> <td>3 phase, 415V AC</td> </tr> <tr> <td>c)</td> <td>Above 200 KW and upto 1500 KW</td> <td>:</td> <td>3 phase, 3.3 kV AC</td> </tr> <tr> <td>d)</td> <td>Above 1500 KW</td> <td>:</td> <td>11 kV</td> </tr> </table> <p>The bidder may adopt 415V/3.3 KV for the drives rated in the range of 160-210 KW.</p> <p>For CHP conveyer motor's rating above 160 kW, 3.3 KV, three phase AC supply is to be used.</p> <p>The voltage rating of the drives indicated above is for basic guideline. Minor variations in above can be accepted on case to case basis based on techno-economic considerations of the various sub-systems.</p> <p>Voltage rating for special purpose motors viz, VFD and screw compressors, shall be as per manufacturer's standard. All the motors ratings on Stacker/ reclaimers shall be 415V ac supply only.</p>				a)	Upto 0.2 KW	:	Single phase 240V AC / 3 phase 415V AC	b)	Above 0.2 KW and upto 200 KW	:	3 phase, 415V AC	c)	Above 200 KW and upto 1500 KW	:	3 phase, 3.3 kV AC	d)	Above 1500 KW	:	11 kV
a)	Upto 0.2 KW	:	Single phase 240V AC / 3 phase 415V AC																	
b)	Above 0.2 KW and upto 200 KW	:	3 phase, 415V AC																	
c)	Above 200 KW and upto 1500 KW	:	3 phase, 3.3 kV AC																	
d)	Above 1500 KW	:	11 kV																	
<p align="center"><b>NORTH KARANPURA STPP</b> (3 X 660 MW) EPC PACKAGE</p>	<p align="center"><b>TECHNICAL SPECIFICATIONS</b> SECTION – VI, PART-B</p>	<p align="center"><b>SUB-SECTION-B0</b> GENERAL ELECTRICAL SPECIFICATION</p>	<p align="center"><b>PAGE</b> 1 OF 11</p>																	

CLAUSE NO.	PROJECT INFORMATION			
1.07.00	<p>The preferred AC control supply voltage shall be 110V for all 415 V non breaker controlled feeders. Control supply voltages other than above may be offered by bidder based on the bidder's standard proven practice.</p>			
1.08.00	<p>The designed fault levels for 11 KV &amp; 3.3 KV systems shall be restricted to 40 kA rms for 1 second and 50 kA rms for 1 second for 415 V systems. The 33 KV system equipments shall have a minimum short circuit fault withstand rating of 12.5 kA for 1 second.</p>			
1.09.00	<p>The nominal voltage of main DC system shall be 220V. DC batteries shall be designed for continuous float operation with trickle charge, hence all the associated components like batteries, battery chargers, DC motors, relays, contactors, timers etc shall be suitable for continuous operation at the maximum continuous battery float voltage including suitable temperature correction factors. The operational limits of variation of DC voltage is (+)10 % to (-)15%.</p> <p>In addition, the bidder may propose 110V, 48V or 24V systems as per requirements of control and instrumentation of his equipment and design.</p>			
1.10.00	<p>The Contractor shall furnish calculations of maximum loading and fault levels under the most onerous conditions for the various equipment/systems as defined else where in the specification to prove adequacy of their parameters. In case any equipment or system is found to be inadequate, it shall be changed/ modified without any additional liability to the Employer.</p>			
<p align="center"><b>NORTH KARANPURA STPP (3 X 660 MW) EPC PACKAGE</b></p>	<p align="center"><b>TECHNICAL SPECIFICATIONS SECTION – VI, PART-B</b></p>	<p align="center"><b>SUB-SECTION-B0 GENERAL ELECTRICAL SPECIFICATION</b></p>	<p align="center"><b>PAGE 2 OF 11</b></p>	

***SECTION – C***

**SPECIFIC TECHNICAL  
REQUIREMENTS**

	<b>3 X 660 MW NORTH KARANPURA STPP</b>	Doc. No PE-TS-405-557-E001
		Volume: IIB
<b>TECHNICAL SPECIFICATION FOR PUBLIC ADDRESS SYSTEM</b>		Section : C
		Rev. : 00
		Page : 1 of 7

## 1.0 INTENT OF SPECIFICATION

This specification covers the design, manufacture, assembly, testing and inspection at vendor's/sub-vendor's works, packing, despatch to site, system engineering and erection & commissioning of central exchange type Public Address System as described in the various sections of this specification. Public Address System shall generally conform to IS. It is not the intent to completely specify all details of design and construction herein.

## 2.0 SCOPE OF SUPPLY AND SERVICES

- 2.1 The scope of supply and services covers the complete supply of equipment and services for central exchange type distributed amplifier Public Address System in accordance with the requirements of various sections of this specification.
- 2.2 The scope of supply and E & C shall be as per Price Schedule enclosed as Annexure-2.
- 2.3 Public address system shall be provided for the entire plant including switchyard, CHP, AHP and other offsite areas.
- 2.4 Consumables such as cable glands, cable lugs, ferrules, tags, self locking clamps, screws, supports, fixing hardware and special supporting structure, as required for outdoor/indoor equipment erection shall be included as part of supply. Wherever the quantity has been specified as on as required basis, the same are to be supplied on as required basis without any cost implication to the Contractor from the quoted lump sum price.
- 2.5 The successful bidder shall furnish the system write-up, complete erection/mounting drawing for each of the equipment, testing & commissioning procedure for individual equipment and for complete PA system during contract stage.
- 2.6 The Bidder's scope shall also include successful demonstration of performance testing specified herein complete in all respects along with cables, junction boxes, earth wire and accessories like standard brackets, nut-bolts, glands, lugs, conduit sleeves, etc., as required, to complete the proper installation conforming to IS: 1881, IS: 1882 of all the equipments supplied as covered in this specification.

## 3.0 TERMINAL POINTS

Incoming power supply to Power Distribution Box (PDB)

## 4.0 POWER SUPPLY:

The system shall be suitable for operation from 240V AC 1-phase supply. For TG building central exchange, there will be two UPS supply feeders. In event of failure of one UPS supply, it will switch automatically to another UPS supply through auto changeover. In CHP area, PA system shall be fed from UPS system.

	<b>3 X 660 MW NORTH KARANPURA STPP</b>	Doc. No PE-TS-405-557-E001
		Volume: IIB
<b>TECHNICAL SPECIFICATION FOR PUBLIC ADDRESS SYSTEM</b>		Section : C
		Rev. : 00
		Page : 2 of 7

## 5.0 ZONE WISE DISTRIBUTION OF SYSTEM

5.1 PA system shall comprise five separate zones:

- a) Zone-I for Unit-1 area
- b) Zone-II for Unit-2 area
- c) Zone-III for Unit-3 area
- d) Zone-IV for common plant area
- e) Zone-V for coal handling area with two sub-zones, sub-zone-I and sub-zone-II.

5.2 All the above zones shall be connected with a central exchange to be located in Control Equipment room of Unit-1. Another exchange to be located in Coal Handling Plant (CHP) Control room, shall connect all the sub-zones of Coal Handling Plant. The Sub zones of CHP areas shall be connected to the central exchange through this exchange only.

5.3 There will be three master control stations for central exchange for three units which will be located in unit control room and another master control station parallel with earlier, shall be located in shift incharge room. Another master control station shall be located in switchyard control room. Each zone shall have number of subscriber stations. Each station can do conversation with other stations and with master control station.

5.4 The master control station for CHP sub-exchange shall be located on CHP control desk. CHP sub-exchange shall be connected to the central exchange for communication with other zones from handsets in CHP sub-zones.

5.5 Typical utility block diagram of different zones & their interconnections is enclosed as per dwg no: PE-DG-405-557-E001. Similarly the system block diagram for PA system is enclosed as per dwg no: PE-DG-405-557-E002.

## 6.0 OPERATION:

6.1 Communication within a zone:

The system shall have two independent channels, which function simultaneously for communication viz page channel & party channel. Each of the two modes shall be open line, common talking type. Paging mode shall be used for locating a person and for general instructions. Party mode shall be used for conversation between individuals without broadcasting the same over the loudspeaker. Whenever the 'Press to page' push button is pressed on any of the handset stations, a pleasant chime shall be broadcast over all the loudspeaker except the one associated with that handset station to attract attention. Conversation, in paging mode shall be heard over all loudspeakers except the loudspeaker associated with the handset station whose 'Press to Page' push button is being held in pressed condition. When 'Press to Page' push button is released, the associated handset shall return to party mode.

	<b>3 X 660 MW NORTH KARANPURA STPP</b>	Doc. No PE-TS-405-557-E001
		Volume: IIB
<b>TECHNICAL SPECIFICATION FOR PUBLIC ADDRESS SYSTEM</b>		Section : C
		Rev. : 00
		Page : 3 of 7

During party channel mode, page channel is free to receive any announcement. A mute switch is provided to mute the associated loudspeaker, if required when engaged in party channel. Simultaneous operation on both modes, i.e. Some handsets on party channel and some handsets on paging channel, shall be possible without any crosswalk between the two channels. During conversation on 'page' mode within a zone, the centralised equipment/hardware of the associated zone shall have the feature to monitor and identify the handset from where conversation is being continued with the 'page' button depressed and the access code of the person.

#### 6.2 Inter zone communication:

It shall be possible from a station in one zone to communicate with another station in a different zone, both in party/page mode through the master control units only located on each unit control desk at control room and shift Incharge room. Further, it shall be possible to broad cast recorded speech, music etc. over the loudspeakers. Communication/announcements within a zone shall not be heard in loudspeakers of other zones.

#### 7.0 TYPES OF HANDSET STATIONS

Following types of handset stations are envisaged:

- a) Type-A: Outdoor Wall/column mounted station with built-in amplifier and horn type speaker. Degree of protection shall be IP 55 for main plant area and IP-65 for CHP area.
- b) Type-B: Indoor desktop mounted station with cone type speaker. Degree of protection shall be IP 32.
- c) Type-C: Indoor control desk Flush mounted type station with built-in amplifier and speaker. Degree of protection shall be IP 32.

Each of the above handset station shall have following:

One - telephone handset, One Cradle switch for resetting the handset., One "Press to Page" push button, One "Press to Mute Loudspeaker" push button, Pre-amplifier and Power amplifier, Indication for 'POWER SUPPLY ON' and Indication for 'PARTY CHANNEL BUSY'. The Type-A handset shall be inside an enclosure with transparent glass door which can be opened through number padlock only.

- d) Type-D: Master control station with built-in amplifier and speaker. Degree of protection shall be IP 32.
- e) Type-E: Portable station complete with handset, speaker, amplifier, push buttons, indication lamps and coupling cable terminated by a plug.
- f) Type-S: Socket for Portable Handset

	<b>3 X 660 MW NORTH KARANPURA STPP</b>	Doc. No PE-TS-405-557-E001
		Volume: IIB
<b>TECHNICAL SPECIFICATION FOR PUBLIC ADDRESS SYSTEM</b>		Section : C
		Rev. : 00
		Page : 4 of 7

Handset transmitter/microphone shall be noise canceling type and all switches and pushbuttons provided on the handset station shall be of encapsulated contact type. Handset transmitter/microphone shall have filters to protect from dust. Each handset shall be provided with one meter (extended) retractable coiled type of cable. All handsets shall have a compact , robust, rust resistant, shock resistant body.

The wall/column mounting handset stations shall be tamper-proof, using internal anchoring bolts and peculiar (e.g. triangular head, counter-sunk) screws which can be loosened only with special keys.

## 8.0 TECHNICAL PARAMETERS

- For overall installation bandwidth (+/-3 dB) shall be 400-6000 Hz.
- For amplifier bandwidth (+/-3 dB) shall be 200-10,000 Hz. Total harmonic distribution shall not be more than 1% at rated output at 1 kHz. Signal/Noise ratio shall be 60 dB.
- For microphone bandwidth (+/-3 dB) shall be 200-7000 Hz. Type shall be noise cancelling type.
- For outdoor wall/column mounted horn type loudspeakers capacity and bandwidth (+/-3 dB) shall be 15W (RMS) and 500-4500 Hz respectively.
- For indoor wall/column mounted cone type loudspeakers, capacity and bandwidth (+/-3 dB) shall be 4W (RMS) and 200-7000 Hz respectively.
- All handset stations and their components shall be capable of continuous satisfactory operation at an ambient temperature of 55 degree centigrade.

9.0 Amplifiers shall be solid state, class-B, Push-pull type, in built with the handset fully conforming to IS: 1301 & IS: 10426 or equivalent international standard. Amplifiers shall have 0-100% volume control setting. with facility for coarse and fine setting alongwith following controls which shall be located inside the Handset Station. - Input sensitivity control, Receiver volume control, Bass cut filter and Anti side tone control feature.

10.0 **CENTRAL EXCHANGE:** Central exchange shall be wide band microprocessor based having associated circuitry for calling station identification and of modular design. This exchange shall consist of all the necessary control hardware, required for operation, monitoring, protection, indication, switching, testing, measurement of all the voltages and load conditions of the entire system, facility for checking of the operation of all the stations and quality of speech from the master control units etc. Systems bandwidth shall be at least 200-10 kHz ( $\pm 10$  dB) and shall not alter frequency response of the open line system. All the central exchange shall be enclosed in a freestanding cabinet to be located in control equipment room all the cable entries shall be from bottom only. Further, all the programming tools that will be required to program/reprogram the system shall also be provided. Central exchange shall be able to cater all the specified zones along with the ability to interconnect at least ten (10) more zones for future expansion.

	<b>3 X 660 MW NORTH KARANPURA STPP</b>	Doc. No PE-TS-405-557-E001
		Volume: IIB
<b>TECHNICAL SPECIFICATION FOR PUBLIC ADDRESS SYSTEM</b>		Section : C
		Rev. : 00
		Page : 5 of 7

11.0 MASTER CONTROL UNIT: Master Control Units shall be microprocessor based and of modular design. These units shall be table top type along with luminous miniature push buttons for interzone communications, alarm tone generation, fire alarm tone generation etc.

#### 12.0 JUNCTION BOXES:

All junction boxes (JB) shall be made of Fibreglass reinforced polyester material with thickness 4 mm, door handle, self-locking with common key, door gasket shall be of synthetic rubber & provided with rail mounted cage clamp type terminal blocks suitable for conductor size upto 2.5 mm<sup>2</sup>. A M6 earthing stud shall be provided. Degree of protection shall be IP 55 minimum for indoor & IP-65 for outdoor applications. The mounting clamps & accessories shall be suitable for mounting on walls, columns, structures etc. The brackets, bolts, nuts, screws, glands required for erection shall be of SS. Colour shall be RAL 7305.

#### 13.0 SIGNAL LOOP LENGTH

The signal loop length will be around 4 Km in unit area, around 8 Km in coal handling plant area and around 7 Km in common plant area from the central exchange. Further, the distance between two stations in areas other than unit may be more than 1 Km. Bidder shall provide necessary repeaters, power supply modules etc to meet the requirement of the same.

#### 14. COLOUR OF EQUIPMENT

Paint shades for all equipments are subjected to BHEL/customer approval during contract stage without commercial implications. All painting shall be through powder coated epoxy base paint.

#### 15. CABLES & CABLING

15.1 The cables shall be armoured FRLS type. Colour of the outersheath shall be YELLOW.

Following power, signal & loudspeaker cables will be used:

- a) Power cable : 3C-2.5 mm<sup>2</sup> Cu armoured.
- b) Signal cable : 4P-0.5 mm<sup>2</sup> (7/0.3mm) Cu overall screened armoured.
- c) Loud speaker cable: 2P-0.5 mm<sup>2</sup> (7/0.3mm) Cu overall screened armoured.

15.2 The cable size between MDF to SDF will be 24P-0.5 mm<sup>2</sup> / 12P-0.5 mm<sup>2</sup> as per requirement.

15.3 The PA system cables will be laid in ready trays routed in different areas of power plant for power & signal cables. Power cable will run in separate trays, similarly the signal cables will run in separate trays.

	<b>3 X 660 MW NORTH KARANPURA STPP</b>	Doc. No PE-TS-405-557-E001
		Volume: IIB
<b>TECHNICAL SPECIFICATION FOR PUBLIC ADDRESS SYSTEM</b>		Section : C
		Rev. : 00
		Page : 6 of 7

15.4 Cable glands shall be double compression type.

#### 16.0 ACOUSTIC HOOD:

An industrial type free standing, floor mounted acoustic hood will be provided in noisy area like Turbine Hall , BFPs, Mill Area etc. The acoustic hood will be made of MS 1.6mm thick/ FRP material 4mm thick. The design noise level within the hood shall be limited to a maximum of 60 dB SIL.

#### 17.0 INTERFACES WITH EXISTING EXCHANGE:

PA system central exchange and/or Master Control Unit shall be interfaced with the existing Telephone Exchange so that it shall be possible to communicate with any station in any zone from any telephone set through Central Exchange and/or Master Control Unit.

Earthing shall be through GI Wire

- 18.0 PA system shall be interfaced with fire alarm panel. Bidder's to provide necessary provision for the same in schemes.
- 19.0 Tentative Locations in different zones for different type of handset stations and loudspeakers and the plot plan of the plant has been attached as annexure 1. Final zonewise locations for various handsets shall be decided during detailed engineering.
- 20.0 Bidder shall furnish separately the power supply requirements (in watts) for both central exchanges along with different stations attached to each exchange to decide the feeder size.
- 21.0 Design engineering includes submission of data sheets of each equipment along with GA drawings, technical write-up of the system, schemes & interconnection dwgs as per equipment layout in different zones, various schedules and bill of material. Mounting arrangement drawings of different equipments, testing & commissioning guidelines, operation & maintenance manuals for complete system.
- 22.0 Makes of equipment/components shall be subject to BHEL/OWNER approval during detailed engineering. However, bidder shall furnish the list of makes along with the offer.
- 23.0 After completion of work at site, bidder shall prepare 'AS BUILT and O&M Manuals'. The number of copies of documents/data to be submitted as distribution print shall be as per enclosed Annexure-4.
- #### 24.0 INSPECTION & TESTING
- 24.1 All equipment shall be subjected to routine test as per relevant standards.

	<b>3 X 660 MW NORTH KARANPURA STPP</b>	Doc. No PE-TS-405-557-E001
		Volume: IIB
<b>TECHNICAL SPECIFICATION FOR PUBLIC ADDRESS SYSTEM</b>		Section : C
		Rev. : 00
		Page : 7 of 7

- 24.2 A sample copy of Quality Plan is enclosed (as Annexure-5) with the specification for compliance. During detailed engineering, the bidder shall furnish this QP for purchaser/customer approval. The changes in the Quality Plan (QP) during customer approval shall be without any implication on cost and delivery.
- 24.3 The bidder shall furnish the type tests certificates as specified in the specification (Annexure 6) for purchaser/customer review/acceptance. If type tests are found non-satisfactory then the bidder has to carry out the type test without any price and delivery implication to BHEL.
- 24.4 For all components / materials, for which Type tests have not been specified in the specification, only type test reports shall be furnished by the bidder. In absence of such type tests reports or in case such reports are not found to be meeting the specification/standards requirements, bidder shall conduct, free of cost to the purchaser, all such type tests according to the relevant standards and reports shall be submitted to the owner for approval.
- 25.0 OTHER IMPORTANT CONSIDERATIONS:-
- 25.1 For price comparison purpose Annexure-2(A ,B & C) shall be considered.
- 25.2 In case of clash of requirement between section-C and section-D, the requirement of section-C will prevail.
- 25.3 Following to be furnished with the technical bid:
- Unpriced Price Schedule (Annexure-2A,2B,2C,2D &2E) with bidder's signature and company stamp.
  - A copy of this sheet ("Instructions to Bidders for Preparing Technical Offer"), with bidder's signature and company stamp.
  - A copy of previous sheet ("List of Contents"), with bidder's signature and company stamp.
- 25.4 DOCUMENTS TO BE FURNISHED BY THE SUCCESSFUL BIDDER in addition to those specified in Section D. GA Drawings with applicable technical details and other drawings/documents as per attached drawing schedule (Annexure 3) shall be furnished after award of contract.

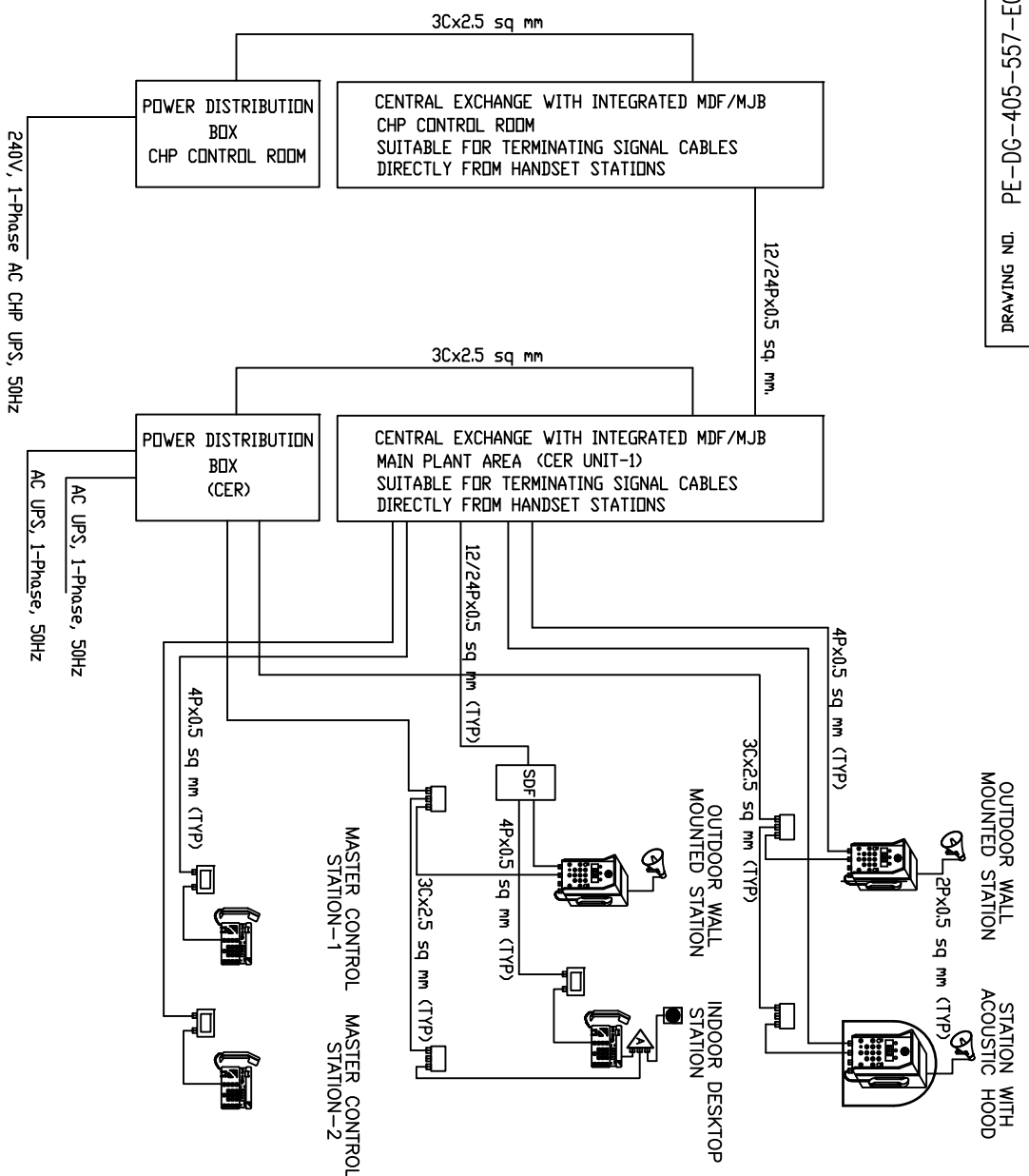

**NOTE:**  
1. SIMILAR CABLE & STATIONS CONNECTION WILL BE FOLLOWED FOR CHP EXCHANGE ALSO.

REV.	DATE	ALTD.	CHD.	APPD.	REV.	DATE	ALTD.	CHD.	APPD.	JOB NO.	298
										STATUS	CONTRACT
										DISTRIBUTION	
										NO.	

# NORTH KARANPURA STPP (3X660 MW)

**PROJECT**  
BHARAT HEAVY ELECTRICALS LTD.  
POWER SECTOR  
PROJECT ENGINEERING MANAGEMENT  
NOIDA

**TITLE**  
SYSTEM BLOCK DIAGRAM FOR  
PUBLIC ADDRESS SYSTEM

MDF/MJB : MAIN DISTRIBUTION FRAME/MAIN JUNCTION BOX  
SDF : SUB DISTRIBUTION FRAME

LEGEND	DESCRIPTION
	AMPLIFIER FOR DESK TOP STATION
	SDF 24 PAIR
	POWER JB
	SIGNAL JB FOR DESKTOP, FLUSH MOUNTED STATION & MASTER CONTROL STATION
	CONE TYPE SPEAKER
	HORN TYPE SPEAKER
	DESK MOUNTED / FLUSH MOUNTED & MASTER CONTROL STATION
	FIELD STATION WITH ACOUSTIC HOOD
	FIELD STATION

DEPT.	CDDE	DRNL.	NAME	SGN	DATE
		DSGN.	SG		
		CHD.	PD		
		APPD.	RG		
DRAWING NO. PE-DG-405-557-E002					
SHEET 1 OF 1 REV. 01					





3 X 660 MW NORTH KARANPURA STPP

**TECHNICAL SPECIFICATION FOR PUBLIC ADDRESS SYSTEM**

Doc. No

PE-TS-405-557-E001

Volume: IIB

Section

Rev. : 00

Page : 1 of 1

**ANNEXURE-1**

**ZONE WISE DISTRIBUTION OF HANDSET STATIONS:**

**1. Zone I/II/III**

Sl. No.	Description	Total Qty	Type
1	ESP Control Room	1	B
2	ID Fan-A	1	A
3	ID Fan-B	1	A
4	Boiler Elevations	9	A
5	FD/PA Fan-A	1	A
6	FD/PA Fan-B	1	A
7	Near ESP Structure	1	A
8	Near Dearator	1	A
9 *	Near TDBFP/HPHeater	1	A
10 *	TG Hall	2	A
11 *	Near TG Main Oil Tank	1	A
12 *	Near MDBFP/LPH	1	A
13	Charger/UPS room (8.5 mtrs)	1	S
14	Near Gas cylinder room	1	A
15	Near TG Seal oil unit	1	A
16	Near Hotwell	1	A
17	Near Clean oil/Dirty oil tank	1	A
18	Control fluid room	1	A
19	Boiler MCC Room	1	B
20	LT Switchgear Room	1	B
21	MV Switchgear Room	1	B
22	CCR (On UCD)	2	C
23	CER	1	B
24	Shift Incharge Room	1	S
25	C&I Shift Engr Room	1	S
26	Programmer Room	1	S
27*	Mill area (Left)	1	A
28*	Mill area(Right)	1	A
29	ACC MCC Room	1	B
30	TG Hall A row	2	S
31	CCR	1	D

	<b>3 X 660 MW NORTH KARANPURA STPP</b>	Doc. No PE-TS-405-557-E001
		Volume: IIB
	<b>TECHNICAL SPECIFICATION FOR PUBLIC ADDRESS SYSTEM</b>	Section
		Rev. : 00 Page : 2 of 1

Notes-

1. Handset stations at Sr. no. marked with "\*" will be provided with acoustic hood. Also, 1 acoustic hoods shall be provided at 1 boiler elevation also which shall be decided during detailed engineering.
2. Exact location of handset stations on boiler platform shall be decided during detailed engineering.

### 3. Zone-IV( Common Area)

Sl. No.	Description	Total Qty	Type
1	Air Compressor House	1	A
2	DM Plant Area	1	A
3	PT Plant Area	1	A
4	Chlorination Plant	1	A
5	Fire Water Pump House (FWPH)	1	A
6	Ash Silo Control Room	1	B
7	Switchyard CR	1	B
8	ACW P/H	1	A
9	Chimney	1	A
10	CPU Regeneration Building	1	A
11	Transformer Yard	1	A
12	FO Pump House	1	A
13	<b>Service Building</b>	<b>1</b>	<b>B</b>
14	Mill Reject compressor house	1	A
15	STP	1	A
16	H2 Plant building	1	A
17	<b>Administrative building</b>	<b>1</b>	<b>B</b>
18	Water System Control Room	1	B
19	AHP Control Room	1	B
20	Ash water pump house	1	B
21	Transport air compressor house	1	A
22	Ash slurry pump house	1	A
23	Fire station	1	A
24	Switchyard bay	1	A
25	Workshop	1	A
26	ACC Area	1	A
27	Shift In charge room	1	D
28	Switchyard Control Room	1	D
29	Canteen	1	A

	<b>3 X 660 MW NORTH KARANPURA STPP</b>	Doc. No PE-TS-405-557-E001
		Volume: IIB
	<b>TECHNICAL SPECIFICATION FOR PUBLIC ADDRESS SYSTEM</b>	Section
		Rev. : 00
		Page : 3 of 1

NOTES:

1. These are tentative locations, Exact location of handset stations shall be decided during detailed engineering.

**3 Zone V- CHP Area**

Sl. No.	Description	Total Qty	Type
1	Bunker Floors	4	A
2	CHP CR	1	C
3	Machinery Wells	4	A
4	MCC Rooms	3	B
5	Pent Houses	6	A
6	Pump Houses	1	A
7	TPs	14	A
8	wagon triplers	6	A
9	Crusher Houses	5	A
10	Track Hopper (at different points)	3	A
11	Reclaimer hopper	2	A
12	other locations (to be decided during detailed engg.)	15	A
13	CHP CR	1	D

Notes-

1. Exact location of handset stations shall be decided during detailed engineering.

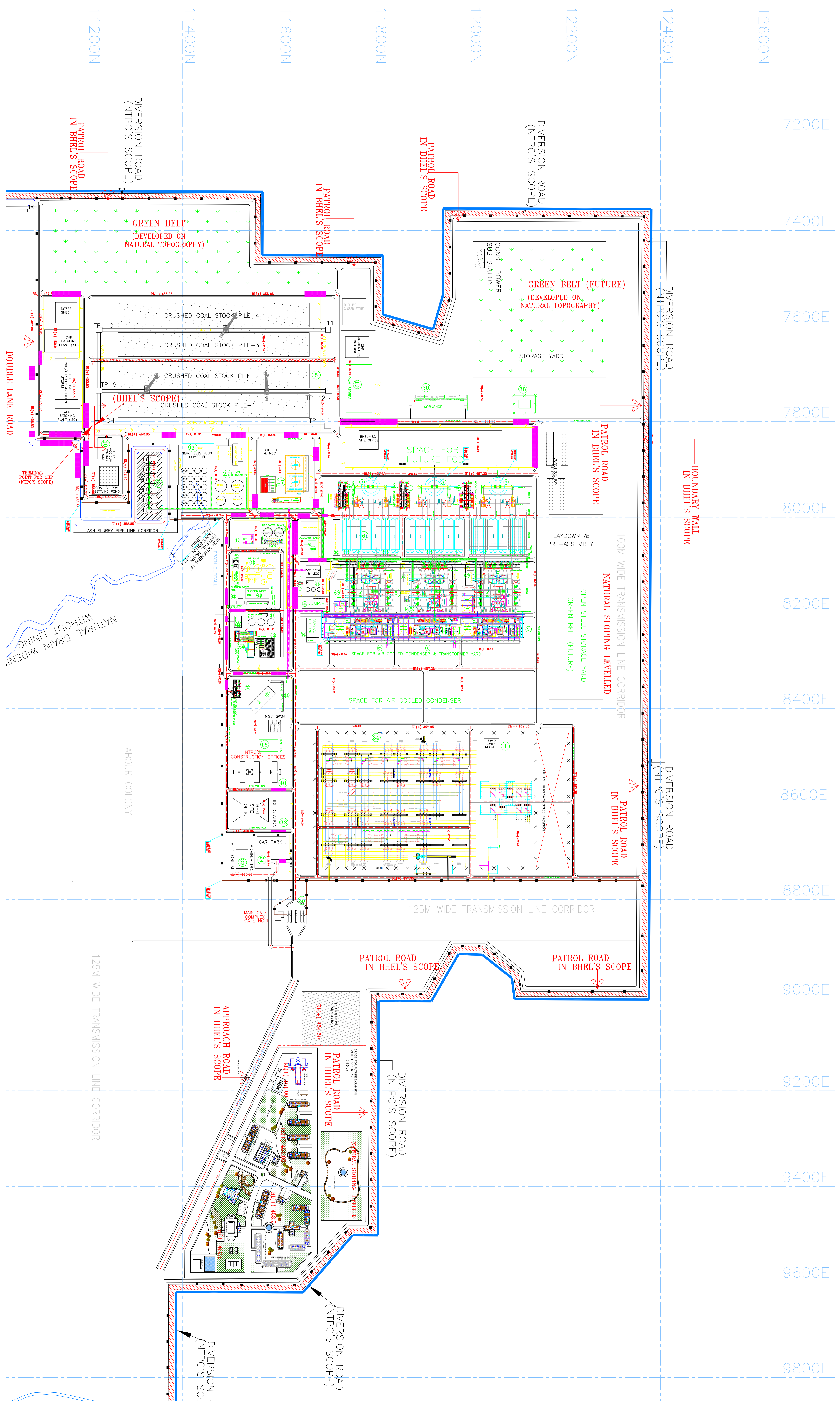

LIST OF BUILDING/EQUIPMENT SHOWN

NO	DESCRIPTION
1	SWITCHYARD
2	TRANSFORMER YARD
3	POWER HOUSE BUILDING
4	BOILER
5	MILL BAY
6	ELECTROSTATIC PRECIPITATOR
7	STACK
8	COAL STOCK YARD
9	ASH HANDLING PLANT
10	MCC CUM CONTROL ROOM FOR CHP
11	PT PLANT
12	D.M PLANT(RO/CONVENTIONAL)
13	D.M. WATER TANKS & PUMP HOUSE
14	SEWAGE TREATMENT PLANT
15	EFFLUENT TREATMENT PLANT
16	CW TREATMENT & CHLORINATION PLANT
17	F.O. UNLOADING, STORAGE & FORWARDING AREA
18	CANTEEN
19	O&M STORES
20	WORKSHOP
21	COOLING TOWER
22	A.C.W. PUMP HOUSE
23	COMPRESSOR HOUSE
24	ADMINISTRATIVE BUILDING COMPLEX
25	FLY ASH SILO / ASH DESPATCH AREA
26	CONSTRUCTION YARD
27	DG SET
28	ESP CONTROL ROOM
29	CONDENSATE STORAGE TANK
30	ASH COMPRESSOR HOUSE
31	CHEMICAL HOUSE-PT PLANT
32	FIRE STATION
33	AUDITORIUM
34	SWITCHYARD CONTROL ROOM
35	MAIN GATE
36	SERVICE BUILDING
37	ASH WATER TANK/ PUMP HOUSE
38	HYDROGEN GENERATION PLANT
39	AUXILIARY BOILER
40	NTPC'S CONSTRUCTION OFFICE SPACES
41	CLARIFIED WATER TANK & PUMP HOUSE
42	FILTERED WATER TANK & PUMP HOUSE
43	CHEMICAL LAB-DM PLANT
44	FIRE WATER TANKS & PUMP HOUSE
45	FIRE WATER BOOSTER PUMP HOUSE
46	CPU REGENERATION AREA
47	BA SLURRY PUMP HOUSE

IE

***BILL OF QUANTITY***

**ANNEXURE- 2 A**

**3X660 MW North Karanpura STPP - Bill of Quantity for Main Items for Public Address System(SUPPLY)**

Item No.	DESCRIPTION	MAKE	MODEL NO.	QUANTITY	Unit	SUPPLY (Rs)		Remarks
						Unit Ex-works	Total Ex-works	
<b>(A)</b>	<b>MAIN EQUIPMENT</b>							
1	Central exchange for unit & common area with integrated MDF/MJB* Microprocessor controlled, digital, programmable central control unit (CCU) equipped for 176 stations and ability to interconnect atleast 10 more zones for future expansion.			1	No.			
2	Central exchange for CHP area with integrated MDF/MJB* Microprocessor controlled, digital, programmable central control unit (CCU) equipped for 80 stations.			1	No.			
3	Master Control Station (MCS) Built-in mic & speaker, handset			6	Nos.			
4	Flush mounted station (FMS) Built-in mic & speaker, handset			10	Nos.			
5	Desktop Station Built-in mic & speaker, handset			32	Nos.			
6	Extension amplifier for FMS and desktop station			42	Nos.			
7	Wall/column mounted, weatherproof field call station with handset and built-in power amplifier with 15W (RMS) and provided with Enclosure with transparent glass door which can be opened through number padlock only**							
(i)	For main plant area with DOP IP-55			110	Nos.			
(ii)	For CHP area with DOP IP-65			60	Nos.			
8	Sub-distribution frame (SDF) 24 pairs *			32	Nos.			
9	Portable handset station with multi-pin plug			6	Nos.			
10	Socket box for Portable handset station			30	Nos.			
11	Wall/ column mounted 4W Cone type loudspeaker			42	Nos.			
12	Wall/ column mounted 15W Horn type loudspeaker							
(i)	For main plant area with DOP IP-55			110	Nos.			
(ii)	For CHP area with DOP IP-65			60	Nos.			
13	Power junction box							
(i)	For indoor area with DOP IP 55			43	Nos.			
(ii)	For outdoor area with DOP IP 65			172	Nos.			
14	Signal junction box			48	Nos.			
15	Weather protecting canopy for field call station			6	Nos.			
16	Sound protecting floor mounted Acoustic hood			24	Nos.			
17	Power distribution box			2	Nos.			
18	Special tools and tackles			1	lot			
19	E & C spares			1	set			
20	Additional item which is not appearing in BHEL's unpriced price schedule format/BOQ but is required for the completeness of system (bidder to give detailed description of same alongwith prices or state nil)			1	lot			Include signal line booster in sufficient nos. (if applicable)

**NOTES:**

- Bidder must indicate the **make & model number** of each item else the offer can not be evaluated.
- The unit rates of supply for all equipment quoted by the bidder shall be firm for a variation of quantities limited to:
  - ±20% of total order value till finalization of engineering details & BOQ.
  - +10% of the total order value in addition to (a) above, till the completion of job.
- Design and engineering charges shall form part of main equipment.
- Main equipment Items, which are not applicable for their system, bidder to mention in "Remarks" column and same shall appear in the unpriced copy of the bid also.
- Any additional item/equipment if required(as per system quoted by the bidder), bidder shall quote it separately with their unit rate & quantities at S. No 20 above.
- \* Bidder shall quote either SCHEME I or SCHEME II of Section D. Whichever is not applicable Bidder shall write N/A in front of that item.
- Bidder to furnish list of special tools & tackles and E & C spares alongwith the offer.
- \*\*Bidder to furnish breakup of unit prices for S. No. 7 (i) & (ii) above in annexure 2 D.

**ANNEXURE- 2 B**

**3X660 MW North Karanpura STPP - Price Schedule E & C for Public Address System**

Item No.	DESCRIPTION	QUANTITY	Unit	E & C(Rs)		Remarks
				Unit	Total	
<b>(B)</b>	<b><u>ERECTION &amp; COMMISSIONING</u></b>					
1	Central exchange for unit & common area with integrated MDF/MJB* Microprocessor controlled, digital, programmable central control unit (CCU) equipped for 176 stations and ability to interconnect atleast 10 more zones for future expansion.	1	No.			
2	Central exchange for CHP area with integrated MDF/MJB* Microprocessor controlled, digital, programmable central control unit (CCU) equipped for 80 stations.	1	No.			
3	Master Control Station (MCS) Built-in mic & speaker, handset	6	Nos.			
4	Flush mounted station (FMS) Built-in mic & speaker, handset	10	Nos.			
5	Desktop Station Built-in mic & speaker, handset	32	Nos.			
6	Extension amplifier for FMS and desktop station	42	Nos.			
7	Wall/column mounted, weatherproof field call station with handset and built-in power amplifier with 15W (RMS) and provided with Enclosure with transparent glass door which can be opened through number padlock only **	170	Nos.			
8	Sub-distribution frame (SDF) 24 pairs *	32	Nos.			
9	Socket box for Portable handset station	30	Nos.			
10	Wall/ column mounted 4W Cone type loudspeaker	42	Nos.			
11	Wall/ column mounted 15W Horn type loudspeaker	170	Nos.			
12	Power junction box	215	Nos.			
13	Signal junction box	48	Nos.			
14	Weather protecting canopy for field call station	6	Nos.			
15	Sound protecting floor mounted Acoustic hood	24	Nos.			
16	Power distribution box	2	Nos.			
17	E & C of any additional item which is not appearing in BHEL's unpriced price schedule format/BOQ but is required for the completeness of system (bidder to give detailed description of same alongwith prices or state nil)	1	lot			

**NOTES:**

1. The unit rates of E&C for all equipment quoted by the bidder shall be firm for a variation of quantities limited to:
  - a)  $\pm 20\%$  of total order value till finalization of engineering details & BOQ.
  - b)  $+10\%$  of the total order value in addition to (a) above, till the completion of job.
2. Fabrication & painting of support structure for various equipment shall be in bidders scope. However, structural steel will be free issue from BHEL.
3. Instruments required for testing & commissioning shall be arranged by the bidder.
4. Cables laying is not in the scope of the bidder (except the local cable from JB to station). However, termination of cables on bidder's equipment is in bidder's scope.
- 5 \* Bidder shall quote either SCHEME I or SCHEME II of Section D. Whichever is not applicable Bidder shall write N/A in front of that item.
6. \*\*Bidder to furnish breakup of E & C unit prices for S. No. 7 above in annexure 2 D.

**ANNEXURE- 2 C**

**3X660 MW North Karanpura STPP - Bill of Quantity for Mandatory Spares for  
Public Address System**

S. NO.	ITEM	QUANTITY	Unit Ex-works(in Rs)	Total Ex-works (in Rs)
	<b>HANDESETS</b>			
(i)	Handset with cord for outdoor station	10 nos.		
(ii)	Handset with cord for indoor station (desk top mounted)	2 nos.		
(iii)	Handset with cord indoor flush mounted	1 no.		
(iv)	Portable Handset	1 no.		
	<b>LOUDSPEAKERS</b>			
(i)	Outdoor horn type loudspeaker	10 nos.		
(ii)	Indoor cone type loudspeaker	2 nos.		
(iii)	Cradle switch	2 nos. of each type		
(iv)	Push buttons of all types and model.	2 nos. of each type		
(v)	Amplifier PCB with all components mounted for wall mounted Handset station	10% of each type		
(vi)	Extension Amplifier PCB with all components mounted for wall mounted Handset station (in case different from (v) above)	2 nos. of each type		
(vii)	JB's of Handset.	2 nos.		
(viii)	JB's of Loudspeaker	2 nos.		
(ix)	Electronic modules of all types.	10% of each type and model		

**ANNEXURE- 2 D****3X660 MW North Karanpura STPP**

<b>Item No.</b>	<b>DESCRIPTION</b>	<b>Unit</b>	<b>SUPPLY (Rs)</b>	<b>E &amp; C (Rs)</b>
<b>(A)</b>	<b><u>MAIN EQUIPMENT</u></b>		<b>Unit Ex-works</b>	<b>Unit prices</b>
7 A	Wall/column mounted, weatherproof field call station with handset and built-in power amplifier with 15W (RMS)			
(i)	For main plant area with DOP IP-55	Nos.		
(ii)	For CHP area with DOP IP-65	Nos.		
7 B	Enclosure with transparent glass door which can be opened through number padlock only	Nos.		

## ANNEXURE- 2 E

### 3X660 MW North Karanpura STPP

<b>PRICE SCHEDULE (RECOMMENDED SPARES FOR 3 YEARS OF OPERATION) - OPTIONAL</b>				
	ITEM DESCRIPTION	QTY	UNIT	UNIT RATE ( EX-WORKS)
(a)	RECOMMENDED SPARES FOR 3 YEARS OF OPERATION	I SET		

NOTE : Bidder to furnish the detailed list of recommended spares with their Unit rate & quantities alongwith the offer.

**ANNEXURE-3****3 X 660 MW NORTH KARANPURA STPP - PA SYSTEM [LIST OF DOCUMENTS & NUMBERING]**

<b>Sl.No</b>	<b>BHEL DRAWING NO.</b>	<b>TITLE</b>
1	PE-V0-405-557-E001	DATA SHEET FOR PA SYSTEM
2	PE-V0-405-557-E002	SYSTEM DESCRIPTION WITH CABLES & EARTHING DETAILS
3	PE-V0-405-557-E003	PA SYSTEM O&M MANUAL
1	PE-V0-405-557-E101	GA OF CENTRAL EXCHANGE (WITH INTEGRATED MDF/MJB) FOR UNIT & COMMON AREA
2	PE-V0-405-557-E102	GA OF CENTRAL EXCHANGE( WITH INTEGRATED MDF/MJB) FOR CHP AREA
3	PE-V0-405-557-E103	GA OF DESKTOP MOUNTED STATION
4	PE-V0-405-557-E104	GA OF MASTER CONTROL STATION
5	PE-V0-405-557-E105	GA OF FLUSH MOUNTED STATION
7	PE-V0-405-557-E107	GA OF FIELD STATION WITH ENCLOSURE WITH TRANSPARENT GLASS DOOR WHICH CAN BE OPENED THROUGH NUMBER PADLOCK
8	PE-V0-405-557-E108	GA OF PORTABLE STATION
9	PE-V0-405-557-E109	GA OF SOCKET FOR PORTABLE STATION
10	PE-V0-405-557-E110	GA OF 4W CONE TYPE LOUD SPEAKER
11	PE-V0-405-557-E111	GA OF 15W HORN TYPE LOUD SPEAKER
13	PE-V0-405-557-E113	GA OF SUB DISTRIBUTION FRAME (SDF) 24 PAIRS
14	PE-V0-405-557-E114	GA OF EXTENSION AMPLIFIER
15	PE-V0-405-557-E115	GA OF SOUND PROTECTING (ACOUSTIC) HOOD (FLOOR MOUNTED)
16	PE-V0-405-557-E116	GA OF CANOPY FOR FIELD STATION
17	PE-V0-405-557-E117	GA OF POWER DISTRIBUTION BOX
18	PE-V0-405-557-E118	GA OF POWER JUNCTION BOX
19	PE-V0-405-557-E119	GA OF SIGNAL BOX
20	PE-V0-405-557-E120	GA MOUNTING ARRANGEMENT DWG
1	PE-V0-405-557-E201	QUALITY PLAN FOR PA SYSTEM
1	PE-V0-405-557-E301	BLOCK DIAGRAM FOR PA SYSTEM
2	PE-V0-405-557-E302	INTERCONNECTION DIAGRAM FOR PA SYSTEM
3	PE-V0-405-557-E303	CABLE LISTING FOR PA SYSTEM
1	PE-V0-405-557-E401	TEST PROCEDURES FOR PA SYSTEM
2	PE-V0-405-557-E402	TYPE TEST REPORTS FOR PA SYSTEM

## ANNEXURE 4

CLAUSE NO.

एन.के.पी.सी.  
NTPC

S.No	Description of Drgs/Docs	No of Prints	No of ROMs/DVDs/Portable Hard Disk	CD
1	Drawings, Data sheets, Design calculations, Purchase specifications and other documents			
	First submission and submission with major changes			
	▪ Layout (A0&A1 sizes)	4	-	
	▪ Other Drawings/Documents (A0&A1 sizes)	2	-	
	▪ P&ID (All sizes)	4	-	
	a) Final drawings/documents (Directly to site)	6	2	
	b) "As Built" Drawing/Documents (Directly to site)	6	2	
	c) Analysis reports of Equipments / piping /structures components/system employing software packages as detailed in the specifications.	2	2	
2	Erection Manual (Directly to site)	4 sets	2	
3	Operation & Maintenance manual	1 set	--	
	i) First Submission			
	ii) Final Submission (Directly to site)	4 sets	2	
4	Plant Hand Book			
	i) First Submission	1	1	
5	Commissioning and Performance Test Procedure manual	1 set	--	
	i) First Submission			
	ii) Final Submission (Directly to site)	4 sets	2	

NORTH KARANPURA STPP  
(3X660 MW)  
EPC PACKAGETECHNICAL SPECIFICATION  
SECTION - VI, PART-C  
BID DOC.NO.:CS-4410-001-2GENERAL TECHNICAL  
REQUIREMENTS  
Annexure-VIPAGE  
83 OF 100

# ***QUALITY PLAN***

**ANNEXURE 5**

		<b>MANUFACTURING QUALITY PLAN</b>						PROJECT :												
		ITEM : Public Address System						BHEL DOC NO: _____												
		<b>SUB-SYSTEM: Master Control Station (MCS)</b>						REV. : 01												
								DATE _____												
								PAGE : 1 OF 5												
								PACKAGE : Main Plant Package												
								MAIN SUPPLIER : BHEL												
SL. NO.	COMPONENT & OPERATIONS	CHARACTERISTICS	CLASS	TYPE OF CHECK	QUANTUM OF CHECK	REFERENCE DOCUMENT	ACCEPTANCE NORMS	FORMAT OF RECORD					REMARKS							
1	2	3	4	5	6	7	8	9	D*	**	10		11							
1.0	PRODUCT																			
1.1	Master Control Station (MCS) & Desk Top Station	1	Aesthetic	Major	Visual	100%	App.Drg.	App.Drg./I. Rep.	I. Report		P	W	W	NTPC/BHEL to witness on 5% samples selected at Random.						
		2	Mechanical	Major	Dim.	100%	App.Drg.	App.Drg./I. Rep.	I. Report		P	W	W							
		3	Electrical	Major	Electrical	100%	Approved Data Sheet	Approved Data Sheet	I. Report			P	W		W					
			Rated input voltage															P	W	W
			Rated output voltage															P	W	W
			THD at 1 KHz.															P	W	W
			Frequency Response															P	V	V
			Input impednce at 1KHz.															P	W	W
		Signal to Noise Ratio								P	W	W								
1.1.1	(Electronic Modules)	5	Burn in test at 50 deg.for 48 hours in energised condition.	Major	Electrical	100%	Approved TP	Approved TP	I. Report		P	W	V							
		<b>BHEL</b>	<u>LEGEND: * RECORDS IDENTIFIED WITH "TICK" SHALL BE ESSENTAILLY INCLUDED BY CONTRACTOR IN QA DOCUMENTATION. ** M:</u>						NTPC DOC NO.:9464-108-01PE-PVQ-Q-061											
MANUFACTURER/SUB-CONTRACTOR SIGNATURE		CONTRACTOR	MANUFACTURER/SUB-CONTRACTOR B: BHEL NOMINATED INSPECTION AGENCY. C:CUSTOMER/CONSUMER NOMINATED AGENCY.				FOR BHEL USE		REVIEWED BY	APPROVED BY	APPROVAL SEAL									

		<b>MANUFACTURING QUALITY PLAN</b>						PROJECT				
		ITEM : Public Address System						BHEL DOC NO:				
		<b>SUB-SYSTEM: Central Exchange</b>						REV. : 01				
								DATE :				
								PAGE : 1 OF 5				
								MAIN SUPPLIER : BHEL				
SL. NO.	COMPONENT & OPERATIONS	CHARACTERISTICS	CLASS	TYPE OF CHECK	QUANTUM OF CHECK	REFERENCE DOCUMENT	ACCEPTANCE NORMS	FORMAT OF RECORD		AGENCY	REMARKS	
1	2	3	4	5	6	7	8	9	D*	**	10	11
1.2	Central Exchange	1 Aesthetic	Major	Visual	100%	App.Drg.	App.Drg.	I. Report		P	W	W
		2 Mechanical		Dim.	100%	App.Drg.	App. Drg.	I. Report		P	W	W
		3 Electrical	Major	Electrical	100%	Approved TP	Approved TP	I. Report				
		Rated input voltage								P	W	W
		Rated output voltage							P	W	W	
1.2.1	(Electronic Modules)	4 Burn in test at 50 deg. C for 48 hours in energised condition.	Major	Electrical	100%	Approved TP	Approved TP	I. Report		P	W	W
		<b>BHEL</b>	<u>LEGEND: * RECORDS IDENTIFIED WITH "TICK" SHALL BE ESSENTIALLY INCLUDED BY CONTRACTOR IN QA DOCUMENTATION. ** M:</u>						NTPC DOC NO.:9464-108-01PE-PVQ-Q-061			
MANUFACTURER/SUB-CONTRACTOR		CONTRACTOR	<u>MANUFACTURER/SUB-CONTRACTOR B:</u>				FOR					
SIGNATURE			<u>BHEL NOMINATED INSPECTION AGENCY.</u>				BHEL					
			<u>C:CUSTOMER/CONSUMER NOMINATED AGENCY</u>				USE		REVIEWED BY	APPROVED BY	APPROVAL SEAL	

		<b>MANUFACTURING QUALITY PLAN</b>						PROJECT :					
		ITEM : Public Address System											
		<b>SUB-SYSTEM: J. Box.(Loud Speaker), Looping JB, MDB, Socket Box for portable Station, Field Call Station, SL1004D</b>						BHEL DOC NO:		PACKAGE : Main Plant Package			
								REV. : 01					
								DATE : .....		MAIN SUPPLIER : BHEL			
								PAGE : 1 OF 5					
SL. NO.	COMPONENT & OPERATIONS	CHARACTERISTICS	CLASS	TYPE	QUANTUM	REFERENCE	ACCEPTANCE	FORMAT OF	AGENCY			REMARKS	
				OF	OF	DOCUMENT	NORMS	RECORD					
				CHECK	CHECK				M	B	C		
1	2	3	4	5	6	7	8	9	D*	**	10	11	
2.0	PRODUCT												
2.1.	J.BOX.( Loudspeaker), Looping J. Box., Main J. Box, Main Distribution Box, MDF, Socket Box for Portable station.	1	Aesthetic	Major	Visual	100%	App.Drg.	App.Drg./I. Rep.	I. Report	P	W	W	NTPC/BHEL to witness on 5% samples selected at Random.
		2	Mechanical	Major	Dim.	100%	App.Drg.	App.Drg./I. Rep.	I. Report	P	W	W	
		3	HV/IR	Major	Electrical	100%	Approved TP	Approved TP	I. Report	P	W	W	
2.2.	FIELD CALL STATION, PORTABLE STATION SL 1004D	1	Aesthetic	Major	Visual	100%	App.Drg.	App.Drg./I. Rep.	I. Report	P	W	W	NTPC/BHEL to witness on 5 samples selected at random of each type per Lot.
		2	Mechanical	Major	Dim.	100%	App.Drg.	App.Drg.	I. Report	P	W	W	
		3	Electrical	Major	Electrical	100%	Approved TP	Approved Data Sheet /Approved TP	I. Report				
											P	W	
			Rated input voltage							P	W	W	
			Rated output voltage							P	W	W	
			THD at 1 KHz.							P	W	W	
			Frequency Response							P	V	V	
	Signal to Noise Ratio							P	W	W			
	Input impedance at 1 KHz							P	W	W			
		<b>BHEL</b>	<u>LEGEND: * RECORDS IDENTIFIED WITH "TICK" SHALL BE ESSENTAILLY INCLUDED BY CONTRACTOR IN QA DOCUMENTATION. ** M:</u>						NTPC DOC NO.:9464-108-01PE-PVQ-Q-061				
MANUFACTURER/SUB-CONTRACTOR SIGNATURE		CONTRACTOR	MANUFACTURER/SUB-CONTRACTOR B: BHEL NOMINATED INSPECTION AGENCY. C:CUSTOMER/CONSUMER NOMINATED AGENCY				FOR BHEL USE		REVIEWED BY	APPROVED BY	APPROVAL SEAL		

		<b>MANUFACTURING QUALITY PLAN</b>						PROJECT :					
		ITEM : Public Address System				BHEL DOC NO:		PACKAGE : Main Plant Package					
		<b>SUB-SYSTEM: Extension Amplifier ,Cone type speaker, Horn Loud Speaker</b>				REV. : 01		MAIN SUPPLIER : BHEL					
						DATE :							
						PAGE : 1 OF 5							
SL. NO.	COMPONENT & OPERATIONS	CHARACTERISTICS	CLASS	TYPE	QUANTUM	REFERENCE	ACCEPTANCE	FORMAT OF RECORD	AGENCY			REMARKS	
							NORMS		M	B	C		
1	2	3	4	5	6	7	8	9	D*	**	10	11	
2.3	EXTENSION AMPLIFIER	1 Aesthetic	Major	Visual	100%	App.Drg.	App.Drg./I. Rep.	I. Report	P	W	W	NTPC/BHEL to witness 3 samples/ Lot selected at random.	
		2 Mechanical	Major	Dim.	100%	App.Drg.	App.Drg./I. Rep.	I. Report	P	W	W		
		3 Electrical	Major	Electrical	100%	Approved Data Sheet/ Approved TP	Approved Data Sheet/ Approved TP	I. Report		P	W		W
		Input sensitivity at 1KHz								P	W		W
		Rated output power								P	W		W
		THD at 1 Khz.								P	W		W
		Frequency Response								P	V		V
		Input impedance at 1 KHz								P	W		W
		Signal to noise ratio								P	W		W
		HV/IR								P	W		W
2.4	CONE TYPE SPEAKER, HORN LOUD SPEAKER	1 Aesthetic	Major	Visual	100%	App.Drg.	App.Drg.I. Rep.	I. Report	P	W	W	NTPC/BHEL witness on 5 sample/ Lot	
		2 Mechanical	Major	Dim.	100%	App.Drg.	App.Drg.I. Rep.	I. Report	P	W	W		
		3 Electrical	Major	Electrical	100%	App. Data Sheet/ Approved TP	App. Data Sheet/ Approved TP	I. Report		P	W		W
		DC Resistance								P	W		W
		4 Functional test											
		SPL at rated output								P	W		W
Sweep test response		P	W	W									
		<b>BHEL</b>	<b>LEGEND: * RECORDS IDENTIFIED WITH "TICK" SHALL BE ESSENTAILLY INCLUDED BY CONTRACTOR IN QA DOCUMENTATION. ** M:</b>				NTPC DOC NO.:9464-108-01PE-PVQ-Q-061						
MANUFACTURER/SUB-CONTRACTOR SIGNATURE		CONTRACTOR	MANUFACTURER/SUB-CONTRACTOR B: BHEL NOMINATED INSPECTION AGENCY, C:CUSTOMER/CONSUMER NOMINATED AGENCY				FOR BHEL USE	REVIEWED BY	APPROVED BY	APPROVAL SEAL			

		<b>MANUFACTURING QUALITY PLAN</b>							PROJECT :						
		ITEM : Public Address System					BHEL DOC NO:		PACKAGE : Main Plant Package						
		<b>SUB-SYSTEM: Weather prot. Canopy Sound Protecting Hood</b>					REV. : 01		MAIN SUPPLIER : BHEL						
							DATE :								
							PAGE : 1 OF 5								
SL. NO.	COMPONENT & OPERATIONS	CHARACTERISTICS	CLASS	TYPE	QUANTUM	REFERENCE	ACCEPTANCE	FORMAT OF	AGENCY			REMARKS			
				OF	OF	DOCUMENT	NORMS	RECORD		M	B	C			
				CHECK	CHECK										
1	2	3	4	5	6	7	8	9	D*	**	10	11			
3.0	Weather protectiong canopy, sound protecting hood	1 Aesthetic	Major	Visual	100%	App.Drg.	App.Drg.	I. Report		P	W	W	NTPC/BHEL to witness 3 samples of each type.		
		2 Mechanical	Major	Dim.	100%	App.Drg.	App.Drg.	I. Report		P	W	W			
4.0	Integrated Testing on PA System	1 Functional	Major	Visual	100%	Approved TP	Approved TP	I. Report					NTPC/BHEL to witness on 5 no. of stations or Min 5 % connected to central exchange.		
		Party call										P		W	W
		Paging call										P		W	W
		Busy tone										P		W	W
		Alert tone										P		W	W
5.0	TYPE TEST	—	—	—	—	—	—	Report	—	—	—	—	Review of type test clearance from NTPC/BHEL Engg. - CHP and Customer		
Note- For Mandatory Spare BHEL has to forword C.O.C for issuance of MDCC.															
		<b>BHEL</b>	<u>LEGEND: * RECORDS IDENTIFIED WITH "TICK" SHALL BE ESSENTAILLY INCLUDED BY CONTRACTOR IN QA DOCUMENTATION. ** M:</u>						NTPC DOC NO.:9464-108-01PE-PVQ-Q-061						
MANUFACTURER/SUB-CONTRACTOR	CONTRACTOR		<u>MANUFACTURER/SUB-CONTRACTOR B:</u>				FOR								
SIGNATURE		<u>BHEL NOMINATED INSPECTION AGENCY.</u>				BHEL									
		<u>C:CUSTOMER/CONSUMER NOMINATED AGENCY</u>				USE		REVIEWED BY	APPROVED BY	APPROVAL SEAL					

PUBLIC ADDRESS SYSTEM						
TESTS						
ITEMS	Test as per standard (A)	Service feature like call station identification, page /party communication, communication between zones etc. (A)	System band width (A)	Effect of input voltage variation (A)	Regulation of output (A)	HV/IR(R)
<b>Public address system *</b>						
Hand Set Stations(IS-9302 Part-III) /IEC-268-3/IS 2147	Y					
Amplifiers ( IS-9302 Part-II)/ IEC-268-2/IS 10426	Y					
Loud Speaker(IS-9302 Part-IV) /IEC-268-3/ IS 2147	Y					
Power Supplies				Y	Y	Y
Central Exchange / Integrated testing		Y	Y	Y		
EPABX As per (DOT/TEC)/Spec	Y					
R-Routine Test A- Acceptance Test Y – Test applicable						
<p><b>Note:</b> 1) Detailed procedure of Environmental Stress Screening test shall be as per Quality Assurance Programme in General Technical Conditions</p> <p>2) This is an indicative list of tests/checks. The manufacturer is to furnish a detailed quality plan indicating the Practices and Procedure adopted along with relevant supporting documents.</p>						

## **Environmental Stress Screening**

All solid state electronic system / equipment / sub assembly shall be free from infant mortile components. For establishing the compliance to this requirement, the contractor / sub – contractor should meet the following.

- 1) The Contractor / Sub – contractor shall furnish the established procedure being followed for eliminating infant mortile components. The procedure followed by the Contractor / Sub – contractor should be substantiated along with the statistical figures to validate the procedure being followed. The necessary details as required under this clause shall be furnished at the stage of QP finalization.

Or

In case the Contractor / Sub – contractor do not have any established procedure to eliminate infant mortile components then two or 10% whichever is less, most densely populated Panels shall be tested for Elevated Temperature Cycle Test as per the following procedure.

### **Elevated Temperature Test Cycle**

During the elevated temperature test which shall be for 48 hours, the ambient temperature shall be maintained at 50° C. The equipment shall be interconnected with devices and kept under energized conditions so as to repeatedly perform all operations it is expected to perform in actual service with load on various components being equal to those which will be experienced in actual service.

During the elevated temperature test the cubicle doors shall be closed (or shall be in the position same as they are supposed to be in the field) and inside temperature in the zone of highest heat dissipating components / modules shall be monitored. The temperature rise inside the cubicle should not exceed 10° C above the ambient temperature at 50° C.

In case of any failure during the test cycle, the further course of action should be mutually discussed for demonstrating the intent of the above requirement.

### **2) Burn in Test Cycle**

The test shall be conducted on all the panels fully assembled and wired including the panels having undergone the above mentioned elevated temperature test.

The period of Burn in Test Cycle shall be 120 hrs and process shall be similar to the elevated temperature test as above except that the temperature shall be reduced to the ambient temperature prevalent at that time.

During the above tests, the process I/O and other load on the system shall be simulated by simulated inputs and in the case of control systems; the process which is to be controlled shall also be simulated. Testing of individual components or modules shall not be acceptable.

During the Burn in Test the cubicle doors shall be closed (or shall be in the position same as they are supposed to be in the field) and inside temperature in the zone of highest heat dissipating components / modules shall be monitored. The temperature rise inside the cubicle should not exceed 10° C above the ambient temperature.

## ANNEXURE-6

## LIST OF TYPE TEST FOR PUBLIC ADDRESS SYSTEM

S No	Equipment	Type test description	Referred standard	Test to be specifically conducted (Yes/No)	BHEL/Customer's approval Req. on test certificate (Yes/No)
1	Central Exchange	• High frequency radiated magnetic field test	IEC 61000-4-3	NO	YES
		• Electrostatic discharge test	IEC 61000-4-2		
		• Susceptibility test	IEC 61000-4-6		
		• Vibration test	IEC 60068-2-6		
		• Dry heat & damp heat test	IEC 60068-2-2 & IEC 60068-2-30		
		• Surge protection test	IEC 61000-4-5		
2	Field call stations, Junction box, power distribution box, Central Exchange, Master Control station, Desktop station, Flush mounted station, MDF/MJB (if not integrated in central exchange)	DOP test (dust test & water test)	Relevant IS / IEC	NO	YES
3	Cone type speaker	Sound pressure level (SPL) before & after DOP test (dust test & water test)	Relevant IS / IEC	NO	YES
		• Type tests as per IS: 9302 Part- IV	IS: 9302 Part- IV		
4	Horn type speaker	• Sound pressure level (SPL) before & after DOP test (dust test & water test)	Relevant IS / IEC	NO	YES
		• Type tests as per IS: 9302 Part- IV	IS: 9302 Part- IV		
		• Dry heat & damp heat test	IEC 60068-2-2 & IEC 60068-2-30		
5	Field Call station	• Dry heat & damp heat test	IEC 60068-2-2 & IEC 60068-2-30	NO	YES
		• Vibration test	IEC 60068-2-6		
		• Electrostatic discharge test	IEC 61000-4-2		
		• Electromagnetic immunity test	As per relevant standard		
		• Surge protection test	IEC 61000-4-5		
		• RF immunity test	As per relevant standard		
6	Amplifier	• Type tests as per IS: 9302 Part- II	IS: 9302 Part- II	NO	YES
7	Microphones	• Type tests as per IS: 9302 Part- III	IS: 9302 Part- III	NO	YES

***SECTION – D***

**STANDARD SPECIFICATION  
FOR  
PA SYSTEM**



TITLE

Technical Specification  
for  
PUBLIC ADDRESS SYSTEM

SPECIFICATION NO. PE-SS-999-557-E001

VOLUME II B

SECTION D

REV 01 DATE 23/03/2012

SHEET 1 OF 26

*PUBLIC ADDRESS SYSTEM*

*SPECIFICATION NO. PE-TS-999-557-E001, Rev. 1*



TITLE

Technical Specification  
for  
PUBLIC ADDRESS SYSTEM

SPECIFICATION NO. PE-SS-999-557-E001

VOLUME II B

SECTION D

REV 01 DATE 23/03/2012

SHEET 2 OF 26

**SUPPLY**



TITLE

**Technical Specification  
for  
PUBLIC ADDRESS SYSTEM**

SPECIFICATION NO. PE-SS-999-557-E001

VOLUME II B

SECTION D

REV 01 DATE 23/03/2012

SHEET 3 OF 26

## CONTENTS

- 1.0 GENERAL
- 2.0 CODES AND STANDARDS
- 3.0 DESIGN REQUIREMENTS (CONCEPTUAL VIEW)
- 4.0 POWER SUPPLY AND GROUNDING
- 5.0 SYSTEM DESIGN ENGINEERING
  - 5.1 ENGINEERING INPUTS
  - 5.2 ENGINEERING OUTPUTS
- 6.0 CONSTRUCTIONAL FEATURES
  - 6.1 CENTRAL EXCHANGE
  - 6.2 MAIN DISTRIBUTION FRAME (MDF)
  - 6.3 SUB DISTRIBUTION FRAME (SDF)
  - 6.4 MAIN JUNCTION BOX (MJB)
  - 6.5 DISTRIBUTED AMPLIFYING SYSTEM
  - 6.6 HANDSET STATIONS
  - 6.7 LOUD SPEAKERS
  - 6.8 JUNCTION BOXES
  - 6.9 MAIN DISTRIBUTION BOARD (MDB)
  - 6.10 WEATHER PROTECTION CANOPY
  - 6.11 SIGNAL LOOP LENGTH
  - 6.12 CABLES AND CABLING
  - 6.13 ENCLOSURES FOR INSTRUMENTS
  - 6.14 INTERFACING WITH EXISTING EXCHANGE
  - 6.15 OTHER
  - 6.16 COMMON REQUIREMENTS OF VARIOUS EQUIPMENT OF SUPPLY
    - 6.16.1 Surface Treatment
    - 6.16.2 Labels



TITLE

**Technical Specification  
for  
PUBLIC ADDRESS SYSTEM**

SPECIFICATION NO. PE-SS-999-557-E001

VOLUME II B

SECTION D

REV 01 DATE 23/03/2012

SHEET 4 OF 26

6.16.3 Earthing

6.16.4 Packing

## 7.0 INSPECTION AND TESTING

## 7.1 INSPECTION

## 7.2 TESTING

7.2.1 Tests at Works

7.2.2 Site Tests

7.2.3 General Requirements of Site Testing

## 8.0 PRICES

## 9.0 PERFORMANCE GUARANTEES

## 10.0 INSTALLATION AND MAINTAINANCE MANUAL

## 11.0 DOCUMENTATION

11.1 DOCUMENTS TO BE FURNISHED WITH THE BID

11.2 DOCUMENTS TO BE FURNISHED BY THE SUCCESSFUL  
BIDDER ALONG WITH DATA SHEET C11.3 DOCUMENTS TO BE FURNISHED BY THE VENDOR DURING  
DETAILED ENGINEERING STAGE



TITLE

**Technical Specification  
for  
PUBLIC ADDRESS SYSTEM**

SPECIFICATION NO. PE-SS-999-557-E001

VOLUME II B

SECTION D

REV 01 DATE 23/03/2012

SHEET 5 OF 26

## 1.0 GENERAL

- 1.1 The scope of this specification covers engineering, design, manufacturing, inspection & testing at works, packing, supply, delivery, unloading and handling at site of Public Address System for efficient and trouble free operation after installing the same at site.
- 1.2 Engineering: The “Engineering” shall broadly cover the detailed design of PA System as per the requirements of this specification, selection of equipment, materials, estimation of quantities etc. and preparation of all drawings necessary for the erection of the system. Complete engineering shall be as per the guidelines of purchaser and shall be subject to the approval.
- 1.3 It is not the intent to specify complete details of design and construction of equipment. However, the equipment shall conform in all respects to acceptable standards of design, engineering and workmanship and shall be capable of performing the required duties in a manner acceptable to purchaser, who shall be entitled to reject any work or materials, which in his opinion is not in conformity with the duty requirements.
- 1.4 Review of the bidder’s documents by the purchaser shall not relieve the bidder from his responsibility for the design and supply.
- 1.5 The Bidder shall guarantee satisfactory performance of the equipment under stipulated variations of voltage and frequency. The design and manufacture shall be such that equipments/components of same type and rating shall be interchangeable.
- 1.6 Bill of Quantities is enclosed in Section C.
- 1.7 Exclusions: Unless mentioned otherwise in Section C,  
 1.7.1 Civil foundations of central exchange, main distribution frames, main distribution boards & civil works like foundations and cable trenches are excluded from the scope of bidder.  
 1.7.2 Supply of Armoured/ unarmoured power cables, screened control cables  
 1.7.3 laying of cables, conduits and grounding materials
- 1.8 In case of any deviation, the bidder shall indicate the same clause-by-clause in the enclosed “Schedule of Deviations”. In the absence of duly filled schedule it will be construed that the bid conforms strictly to the specification.

## 2.0 CODES AND STANDARDS

- 2.1 The equipment covered under this specification shall be designed, constructed and tested in accordance with latest revisions of applicable codes/ standards.
- 2.2 The equipments furnished under this specification shall conform to the latest revisions of the following standards.
- |         |  |
|---------|--|
| IS10426 | PA System amplifiers-recommendations for minimum performance requirements and PA System amplifiers-recommendations for general requirements. |
| IS1882  | PA system-code of practice for out door installations.   |
| IS1881  | Indoor amplifying and sound reinforcement system-code of practice for installation.  |
| IS1031  | Method of measurements on loudspeaker and loud speakers systems.   |
| IS2382  | Recommended mounting dimensions of loud speakers.  |



TITLE

**Technical Specification  
for  
PUBLIC ADDRESS SYSTEM**

SPECIFICATION NO. PE-SS-999-557-E001

VOLUME II B

SECTION D

REV 01 DATE 23/03/2012

SHEET 6 OF 26

IS9302	Characteristics and Methods of Measurement for sound System equipment.
IS616	Code of safety requirement for mains operated electronic and related apparatus.
IS7741	Specification for loudspeaker.
IS13947	Degrees of protection provided by enclosures for low voltage switchgear and control gear.
IS9537	Specification for conduits for Electrical (Part-I, II) installation/wiring

Equivalent IEC in lies of IS are also acceptable.

The system shall be adequately protected from signal and power line noise and meet the Surge Withstand Capability (SWC) requirements of ANSI C37.90 A/IEEE standard 472-1989 equivalent.

### 3.0 DESIGN REQUIREMENTS (CONCEPTUAL VIEW)

- 3.1 The PA system shall essentially comprise of a number of communication handset stations each of which will be provided with a telephone handset, amplifier, hook micro-switch (if provided, will be spring return to normal type), loudspeaker muting switch (spring return to normal or push button type Volume control, any other associated equipment and the loud speaker.
- 3.2 The PA system shall be of two channel open type having facilities for simultaneous communication on two modes namely 'PAGING' and 'PRIVATE' without any interference.
- 3.3 On the PAGING MODE, conversation shall be heard over the loud speakers for all to hear and this shall normally be used to locate people and also to convey messages of general nature.
- 3.4 On the PRIVATE MODE, conversation shall not be heard over the loud speakers, but it shall be carried over the telephone handsets. This mode shall be used for actual conversation, exchange of information and issue of specific instructions.

### 3.5 ZONE WISE DISTRIBUTION OF SYSTEM

The central exchange type PA system shall comprise of a number of separate zones as specified in section-C. The various zones shall be connected with a central exchange to be located In Control room/Control Equipment room. There will be a corresponding number of master control stations. Each zone shall have number of subscriber stations. Each station can do conversation with other stations and with master control station.

### 3.6 Communication within a zone

- 3.6.1 It shall be possible to make a paging call by lifting the hand set hook switch / hand free mode by pressing the page switch on all call / selected group basis. This shall initiate a call attention tone to be transmitted to all the speakers and gets off automatically after a preset time. The paging message shall then be transmitted over all the loudspeakers when the paging person shall speak in the microphone of the handset. While paging under this channel it shall be possible to mute the loudspeaker near the paging handset to eliminate the acoustic feed back. The page switch shall then be released to allow the paged person to come to the nearest hand set station. After lifting the handset off the hook of the nearest handset station it shall be possible for the paged persons to carry on the conversation on the private mode with the party. The system shall have the conference facility in either of the channels by any no. of persons by simply lifting the handset off the hook and selecting the required channel \_



<b>TITLE</b>  <b>Technical Specification for PUBLIC ADDRESS SYSTEM</b>	<b>SPECIFICATION NO.</b>	PE-SS-999-557-E001
	<b>VOLUME</b>	II B
	<b>SECTION</b>	D
	<b>REV</b> 01	<b>DATE</b> 23/03/2012
	<b>SHEET</b>	7    OF    26

3.6.2 The system shall have minimum following features:

- Normal call- Communication between two handsets within(ref S.N. 3.4 Above)
- Paging\_ -Ref S.N. 3.3 above
- All call- All the field stations terminated on the MCD can be contacted by using this feature. Group call- More than two handsets should be able to join the conversation
- Priority call- Reset feature on MCD, using this feature an existing conversation can be superseded for making any emergency announcement
- Interfacing facility with existing PA system/EPBAX System

3.6.3 Unless requested to be routed through the central exchange, announcements/ communication within a zone shall not be audible in other zones.

3.7 Interzone communication

3.7.1 Each of the zones shall be connected to a central exchange.

3.7.2 For sub-zones of zone, all the communication facilities like paging and party mode communication as described above between the two sub-zones shall be possible as if any have now become a single zone.

3.7.3 It shall be possible to communicate from a station in one zone to another station of different zone through a master control unit to be located on unit control desk. Another master control unit, in parallel with earlier ones, shall be located in shift incharge room. Further, suitable interface with telephone exchange (existing/new) shall be provided so that it shall be possible to communicate with any station in any zone through master control unit from any telephone set. The central exchange shall have the capacity of future expansion in number of stations, as specified in section-C. diagnostic facility of individual equipment shall be provided.

4.0 **POWER SUPPLY AND GROUNDING**

4.1 Unless specified otherwise in Data Sheet-A, the system shall be suitable for operation from 240V AC 1-phase UPS supply. There will be two feeders of 240V AC 1-phase UPS supply. In event of failure of one UPS supply, it will switch automatically to another UPS supply.

4.2 All panels, desks, cabinet shall be provided with a continuous bare copper ground bus. The ground bus shall be bolted / welded to the panel structure and efficiently ground the entire structure.

4.3 If microprocessor control, monitoring and information system or backup control system requires its own unique and isolated grounding requirements, then these requirement should be clearly stated and shall be provided, so as to ensure proper operation of the above mentioned system.

4.4 Connections of cables and changeover facility for power supply connections shall be the scope of the vendor.

5.0 **SYSTEM DESIGN ENGINEERING**



TITLE

**Technical Specification  
for  
PUBLIC ADDRESS SYSTEM**

SPECIFICATION NO. PE-SS-999-557-E001

VOLUME II B

SECTION D

REV 01 DATE 23/03/2012

SHEET 8 OF 26

5.1 ENGINEERING INPUTS: Complete engineering shall be done by the vendor on the basis of following documents to be furnished by purchaser:

- a) Area wise allocation of handsets & loudspeakers and their type.
- b) Layout drawings of areas.

5.2 ENGINEERING OUTPUTS: Vendor shall prepare and submit following documents and drawings for purchaser's approval:

- a) Technical write-up (system Description).
- b) Bill of quantities for all items.
- c) GA drawing cum technical datasheet of all the equipments as per BOQ.
- d) Mounting arrangement drawings.
- e) Interconnection diagram showing the interconnection among Main Distribution Box, Master Handset Station, JBs, Handsets, Loud Speakers and also covering the sizes of cable.
- f) Conductor sizes of cables and wires with voltage drop calculations.
- g) Cable schedule.
- h) Testing and commissioning guidelines
- i) O& M Manuals
- j) Type test report
- k) Test procedure if required

## 6.0 CONSTRUCTIONAL FEATURES

Public Address system shall comprise of central exchange, Handset stations, master control stations along with their associated distributed amplifier and loud speakers, Main distribution box/Junction box, a number of communication handset stations along with their associated loud speakers and other associated equipment. Details of each of these and other items required to make the system complete are furnished below.

### 6.1 CENTRAL EXCHANGE

Microprocessor controlled electronic exchange unit is stored programme controlled (SPC) unit with distributive processing. Switching shall be fully digital using Time Division Multiplexing (TDM) and Pulse Amplitude Modulation (PAM)/Space switching technique. The fully digital switching provides higher number of simultaneous communication links, better reliability, advanced features with no cross talk and other problems related to conventional systems.

The electronic exchange is a central control unit (CCU) comprising of rack, power supply arrangement, and control processors with control wiring. In the CCU, microprocessor controls the operation and power supplies of the system. Central Exchange shall have modular type construction for the purpose of easy expansion, maintenance, operation and fault detection. The racks are the modular mechanical structures mounted in a cabinet.

Central exchange shall be wide band microprocessor based modular design. This exchange shall consist of all the necessary control hardware, required for operation, monitoring, protection, indication, switching, testing, measurement of all the voltages and load conditions of the entire system, facility for checking of the operation of all the stations and quality of speech from the master control units etc. All the card etc. shall be plug in type. Solder less termination shall be provided for every wiring. Systems bandwidth shall be at least 200-10 kHz ( $\pm 10$  dB) and shall not alter frequency response of the open line system. The various oscillators for the ring tone, all tones shall be mounted inside the exchange and shall be complete in all respects. The central exchange shall be enclosed in a freestanding cabinet to be located in control equipment room all the cable entries shall be from bottom only. The working of the



<b>TITLE</b>  <b>Technical Specification for PUBLIC ADDRESS SYSTEM</b>	<b>SPECIFICATION NO.</b>	PE-SS-999-557-E001
	<b>VOLUME</b>	II B
	<b>SECTION</b>	D
	<b>REV</b> 01	<b>DATE</b> 23/03/2012
	<b>SHEET</b>	9    OF    26

system shall be noiseless such that the same can be installed in the office area.

Further, all the programming tools that will be required to program/reprogram the system shall also be provided.

Unless otherwise specified in Section C, Main Distribution Frame (MDF) /MJB as specified below at 6.2 shall form part of the central exchange cabinet ie Central exchange shall be suitable for terminating signal cables directly from Handset stations.

#### **SCHEME I:**

##### 6.2 MAIN DISTRIBUTION FRAME (MDF)

6.2.1 The main distribution frame (MDF) shall consist of two sides. On one side the cables from exchange equipment shall be brought and terminated, on the other side the cables from extension stations are brought and terminated. Thus providing interconnections through jumper wires. The MDF connectors shall have screwless cage clamp (WAGO) type terminals.

6.2.2 The MDF shall be suitable for wall/floor mounting and shall be flexible by way of connecting any extension line to any other exchange line.

6.2.3 The MDF shall be complete with fuse mountings and shall be fitted with delayed action fused on the extension side. It shall be complete with requisite number of test jack assemblies on the exchange side.

6.2.4 The MDF shall be dust proof and shall be suitable for floor/ wall mounting along with all facilities and hardwares. The mounting shall be done by means of nuts and rawl plug of appropriated size. Degree of protection shall be IP-55.

##### 6.3 SUB-DISTRIBUTION FRAME (SDF)

6.3.1 The sub-distribution frame (SDF) shall be of 24 pairs with screwless cage clamp (WAGO) type terminals module. SDF shall be of minimum 14 SWG MS sheet enclosed over suitable angle iron framework with base channel, pedestal etc as required for outdoor installation with flush/wall mounting arrangement. Degree of protection shall be IP-55.

#### **SCHEME II :**

##### 6.4 MAIN JUNCTION BOX

6.4.1 Main Junction Box shall have provision for cable termination for looping of handsets. Handsets with in zone are connected in serial connection and will be terminated to MJB. The MJB will establish link between handsets and central exchange.

Maximum 10 No's handset can be connected in one serial connection of MJB with limitation upto 1.5Km loop length exceeding which signal line booster shall be provided.

##### 6.5 DISTRIBUTED AMPLIFYING SYSTEM

The amplifier system shall be distributed type i.e. each handset station/ loudspeaker shall have its own preamplifier, line amplifiers (wherever required, shall be provided for long line signal transmission) and power amplifiers to suit the loudspeaker capacity. The system shall be as below:

a) Unit amplifying system shall be designed to deliver the wattage of connected load in the unit system.

b) The amplifiers shall be designed for high quality amplification. The amplifiers shall be class-B



TITLE

**Technical Specification  
for  
PUBLIC ADDRESS SYSTEM**

SPECIFICATION NO. PE-SS-999-557-E001

VOLUME II B

SECTION D

REV 01 DATE 23/03/2012

SHEET 10 OF 26

push-  
pull type as per IS616, IS10426 or equivalent and the range of frequency response shall not make the amplifiers liable to pick up low and high frequency noise which might disturb the original speech

reproduction. Frequency response shall be as per Data Sheet A.

- c) The amplifiers shall be heavy-duty type.
- d) The amplifiers shall be of solid-state electronic type and compact in construction.
- e) Pre-amplifying stages shall be furnished to make it suitable for operation with low level input such as microphone.
- f) Suitable arrangement shall be provided for amplifiers as well as preamplifier, to cut down the power requirement during standby or idling time in order to minimise open line hum as well as unnecessary loss of power.
- h) Controls to be provided.
  - i. 0 - 100% volume control setting with facility of coarse and fine setting.
  - ii. Input sensitivity control.

All these controls shall be located inside the handset station.
- i) Wherever a number of loud speakers are connected to one handset, suitable amplifier shall be provided.
- j) Amplifier set of a handset station shall be complete with power amplifier, voltage stabiliser, mike preamplifier, etc. and housed in the control box of handset station.
- k) The various amplifiers shall be modular in construction (preferably card type edge connectors) for ease of maintenance and trouble shooting.

## 6.6 HANDSET STATIONS

6.6.1 The following type of handset stations shall be offered as per BOQ:

- a) Desk mounted master type
- b) Desk mounted indoor type
- c) Wall/ Column mounted indoor type
- d) Wall/ Column mounted outdoor type
- e) Portable handsets

### 6.6.2 Facilities

- a) Master Station:

Master Control Units shall be microprocessor based and of modular design. These units shall be mosaic grid compatible flush mountable/table mounted type along with flexible goose neck type microphone, luminous miniature push buttons for interzone communications, alarm tone generation, fire alarm tone generation etc.

However, master control unit for CHP zone (if required) shall be table/desktop monitoring type.

The master station of each group shall have following operational features:

- i. Originate calls within its own group on "Normal" as well as on "Priority" basis.
- ii. Communicate with handset stations of a particular group.
- iii. Call handset stations of all groups on "All Call Basis".
- iv. Facility for generating and introducing the siren tone in page channel.

- b) Handset Station:

Each of the handset stations shall have the following facilities:



TITLE

**Technical Specification  
for  
PUBLIC ADDRESS SYSTEM**

SPECIFICATION NO. PE-SS-999-557-E001

VOLUME II B

SECTION D

REV 01 DATE 23/03/2012

SHEET 11 OF 26

- i. Originate and receive calls within its own group.
- ii. Receive calls from any of the group masters.
- iii. Communicate with handset stations as well as the group master of other group via his group master station.

Each handset station shall have following:

- (i) One (1) - telephone handset.
- (ii) One (1) - Cradle switch for resetting the handset.
- (iii) One (1) - "Press to Page" push button.
- (iv) One (1) - "Press to Mute Loudspeaker" push button.
- (v) Pre-amplifier and Power amplifier.
- (vi) Indication for "A.C. SUPPLY ON".
- (vii) Indication for "PARTY CHANNEL BUSY".

#### 6.6.3 Material

- a) The desk/ wall mounted indoor handsets shall be of elegant look and be made of die cast aluminium/ mild steel/ fibre glass/ reinforced polyester or any other material subject to prior approval of purchaser.
- b) Wall mounted outdoor handsets shall be made of high impact polystyrene/ fibre glass/ reinforced polyester or any other suitable material to prevent it from breaking due to fall or rough handling etc.
- c) However the material of handsets shall be subject to purchaser's approval.

6.6.4 The outdoor wall/ column mounted handsets shall be of weatherproof construction and shall be provided with neoprene gaskets. Suitable pilfer protection of wall/ column mounted handset stations shall be provided with the help of internal anchoring bolts and special (e.g. triangular) screws which can be operated only by special spanners.

Outdoor handsets shall be provided with lockable type cover for protection against pilferage. Alternatively, pilfer protected wall/column mounted handset stations with built-in microphone/ loudspeaker shall be provided. Vendor to provide either or both the alternatives as specified in BOQ.

6.6.5 Wall/ column mounted instruments shall be heavy duty type and shall also be suitable for dust and noise laden atmosphere.

6.6.6 Desk mounting type (indoor) and wall mounting column type (outdoor) handset stations shall have a degree of protection as follows:

Indoor desktop mounted - IP32

Outdoor (including CHP Area) Wall/column mounted - IP55

6.6.7 All the switches, including the hook switch shall be encapsulated dustproof micro-switches. Alternatively, in place of micro-switches, reed relays/ tactile push switches can be offered. Any other suitable mechanism may be used subject to prior approval of purchaser (before placement of order). All switches shall be suitably protected from the prevalent atmosphere and shall have an extremely long life.

6.6.8 Each handset shall be provided with sensitive dynamic noise cancelling type retractable coil type of cord of length not less than 1.2 metres when stretched.

6.6.9 The amplifier units in the handset station shall be plug-in type so that maintenance of the faulty unit can be done without much downtime. These amplifiers shall be of special design suitable for industrial use such that while providing high line drive audio signal, it shall also provide a special anti side tone



<p>TITLE</p> <p style="text-align: center;"><b>Technical Specification for PUBLIC ADDRESS SYSTEM</b></p>	SPECIFICATION NO.	PE-SS-999-557-E001
	VOLUME	II B
	SECTION	D
	REV 01	DATE 23/03/2012
	SHEET	12 OF 26

circuit.

6.6.10 The db level of the announcement at any station by its own handset shall be lower than the announcement at the same station by any other handset. This shall be provided to ensure that after all the line losses, the db level of announcement from any other station at a particular station is not less than the db level of announcement of that station itself. Vendor shall demonstrate the above at site.

6.6.11 For intelligibility of the human speech, the microphones of the handsets shall be noise cancelling along with directional features by providing necessary acoustic tailoring of frequency response for external noise. Frequency response and type of microphone shall be as per Data Sheet A.

6.6.12 The handset shall be mounted on or within a control box complete with matching transformer, cradle switch, page switch, loud speaker mute switch, power indication lamp, terminal strips, call master switches etc. The handset shall also contain amplifying system of the station. "Private Channel Busy" indication shall also be provided.

6.6.13 Power terminals shall be shrouded. Isolating switch & fuses for incoming power supplies shall be mounted inside handset.

6.6.14 Portable Handsets/ Sockets

- a) For portable handsets, multi-pin sockets with inbuilt power supply unit shall be provided. Multi-pin socket shall be suitable for outdoor operation with IP55 degree of protection.
- b) Degree of protection of portable handsets shall be as specified in Data Sheet A.
- c) Portable handsets shall be light in weight (upto 5Kg) but sturdy in design and shall be housed in a weather proof enclosure with shoulder straps.
- d) Separate provision of power supply for portable handset will not be provided by BHEL
- e) Length of connecting wire from socket to portable handset should be 5 meter minimum.

6.7 LOUD SPEAKERS

6.7.1 Re-entrant type

- a) Re-entrant horn type speakers shall be provided with line matching transformer, and bracket suitable for wall/ column mounting.
- b) Material and degree of protection shall be as specified in Data Sheet A.
- c) For distributed system, volume level adjustment shall be provided at handset if the line-matching transformer is not provided.
- d) The mounting bracket shall be with adjustable base suitable for vertical movement. However, it shall be possible to change the axis of rotation by loosening the screws. Firm fixing arrangement with spring lock washers shall be provided.
- e) Other technical parameters for re-entrant horn type speakers shall be as per Data Sheet A.

6.7.2 Cone Type

- a) Permanent magnet, cone type speaker with line matching transformer shall be housed in a sturdy metal cabinet suitable for wall/ column or ceiling mounting as specified in the schedules and drawings.
- b) Material and degree of protection shall be as specified in Data Sheet A.
- c) For distributed system, volume level adjustment will be provided at handset if the line-matching transformer is not provided.
- d) The cabinet shall have gridded metal faceplate to diffuse high frequencies and prevent damage to the speaker. Housing shall be treated with acoustic under-coats to prevent resonance.
- e) Other technical parameters for cone type speakers shall be as specified in Data Sheet A.



TITLE  <b>Technical Specification for PUBLIC ADDRESS SYSTEM</b>	SPECIFICATION NO.	PE-SS-999-557-E001
	VOLUME	II B
	SECTION	D
	REV 01	DATE 23/03/2012
	SHEET	13 OF 26

## 6.8 JUNCTION BOXES

### 6.8.1 Type of Junction Boxes

- a) Power Junction Box: This type of junction box shall be used for looping of incoming and outgoing power cables for handset stations.
- b) Signal Junction Box: If required, this type of junction box shall be used for looping of incoming and outgoing signal cables for handset stations.

If Signal JB is not the part of Power junction Box it should be provided for Desktop station, flush mounted and master control station separately. In case Power Junction Box can accommodate Signal cable termination and power cable termination both then Bidder shall not quote for SJB.

Number of ways	12/24/36/48/64/72/96/128 with 20% spare terminals
Material & thickness	Fibre glass reinforced polyester (FRP) 4 mm thick/ Mild Steel (MS) 2mm thick/ Al LM6 3 mm thick
Surface	Hot dip galvanised(except for Al Alloy LM6 which shall be painted )
Type	Screwed at all four corners for door. Door handle shall be of stainless steel (SS). Self-locking . Door gasket shall be of synthetic rubber
Mounting clamps & Accessories	Suitable for mounting on walls / columns / structures etc. The brackets bolts, nuts, screws, glands and lugs required for erection shall be of brass.
Type of terminal block	Rail mounted maxitermi or cage-clamp type suitable for conductor size upto 2.5 mm <sup>2</sup> . A M6 earthing stud shall be provided
Protection class	IP-55 (minimum) for all applications including CHP AREA.

- 6.8.2 It shall be possible to isolate any part of the circuit during maintenance/ testing without affecting the other circuits.

## 6.9 MAIN DISTRIBUTION BOARD (POWER Distribution Board)

- 6.9.1 Main distribution board shall be used for distribution of incoming power supply to different loops. Construction of main distribution board shall be similar to other junction boxes. Degree of protection and material shall be as specified in Data Sheet A.

- 6.9.2 Main distribution Board shall consist of two separate units:

- a) Auto changeover Box  
Auto changeover box shall have provision for terminating incoming AC normal and UPS supply and the outgoing line to PA System distribution box. Suitable switch-fuse units/MCB shall be provided independently for both the incoming supplies.  
Heavy-duty auto changeover contactor(s) and indicating lamps for "Supply Healthy" indication shall be provided. Vendor to ensure that no supply paralleling or fault coupling occurs during changeover.

- b) Distribution box  
Distribution box shall be used for distribution of power supply to the different loops. Suitable number of outgoing switch-fuses and incoming switches shall be provided.

Auto changeover box and distribution box may be accommodated in a single box.

Main distribution box shall be of MS sheet with thickness 16 SWG. MDB shall have provisions of two inputs with auto changeover and 12 outputs (minimum), MCB at input and MCB & HRC fuse at output.

- 6.10 PDB shall be wall/column mounted. Necessary glands required for cable entry shall be provided along with PDB.WEATHER PROTECTING CANOPY / ACOUSTIC HOOD



<p>TITLE</p> <p style="text-align: center;"><b>Technical Specification for PUBLIC ADDRESS SYSTEM</b></p>	SPECIFICATION NO. PE-SS-999-557-E001	
	VOLUME	II B
	SECTION	D
	REV 01	DATE 23/03/2012
	SHEET	14 OF 26

#### 6.10.1 WEATHER PROTECTING CANOPY

Weather protecting canopy shall be provided for outdoor field call station to meet the DOP IP-65 for CHP area and IP-55 for all other outdoor areas. The canopy shall be made of 18SWG MS/ 1.75 mm minimum glass fiber material to house the field call stations.

#### 6.10.2 ACOUSTIC HOOD

The handset stations in the noisy areas like turbine Hall, BFP, firing floor, mill area, etc., shall be housed in Acoustic hoods. The acoustic hood will be made of MS material (Minimum 1.6mm thick)/FRP material (3 mm thick), identical to panels, paint finish. An industrial type free standing, wall mounted hood shall be used for providing the above requirements. The design noise level within the hood shall be limited to a maximum of 60 dB SIL. The Stations envisaged inside the acoustic hood shall not be provided with canopy.

#### 6.10.3 ACOUSTIC BOOTH : Sound protecting Industrial type free standing booth

Floor mounted Acoustic booth shall be 850(L)X700(W)X2200(H) mm and made of MS 1.6mm thick/ FRP material 4mm thick. The degree of protection for acoustic booth shall be IP -55. Hinged door entry shall be provided. Suitable table /Mounting arrangement shall be provided inside the booth for mounting the handset.

#### 6.11 SIGNAL LOOP LENGTH

The signal loop length will be around 4 Km in unit area, around 8 Km in coal handling plant area and around 7 Km in common plant area from the central exchange. Further, the distance between two stations in areas other than unit may be more than 1 Km. Bidder shall provide necessary repeaters, power supply modules etc to meet the requirement of the same. No. of Repeaters will be indicated in BOQ section C/

#### 6.12 CABLES & CABLING

Following power, signal & loudspeaker cables will be used:

- a) Power cable : 3C-2.5 mm<sup>2</sup> Cu armoured.
- b) Signal cable : 4P-0.5 mm<sup>2</sup> (7/0.3mm) Cu overall screened armoured.
- c) Loud speaker cable : 2P-0.5 mm<sup>2</sup> (7/0.3mm) Cu overall screened armoured.

The cable size between MDF to SDF will 24P-0.5 mm<sup>2</sup> / 12P-0.5 mm<sup>2</sup> as per requirement.

**If different size of cable is required, bidder must intimate in their offer.**

6.12.1 The PA system cables will be laid in ready trays routed in different areas of power plant for power & signal cables. Power cable will run in separate trays, similarly the signal cables will run in separate trays.

#### 6.13 ENCLOSURE FOR INSTRUMENTS & OTHER EQUIPMENTS

Unless otherwise indicated with the equipment, all panels, desks, cabinets and enclosures furnished shall at least comply with the requirements of protection classes as indicated below:

Indoor air-conditioned (AC) areas	-	IP22
Indoor non air-conditioned (AC) areas	-	IP42
Ventilated enclosures	-	IP42
Non-Ventilated	-	IP54
Outdoor(included CHP)	-	IP55

The design of panels, cabinets, enclosures and packaging density of components mounted therein shall be such that the temperature rise does not exceed 10<sup>0</sup> C above the ambient under the worst conditions. All panels/ cabinets housing electronic equipment in non-air-conditioned area shall be provided with redundant cooling fans along with filters.



<b>TITLE</b>  <b>Technical Specification for PUBLIC ADDRESS SYSTEM</b>	<b>SPECIFICATION NO.</b> PE-SS-999-557-E001	
	<b>VOLUME</b>	II B
	<b>SECTION</b>	D
	<b>REV</b> 01	<b>DATE</b> 23/03/2012
	<b>SHEET</b>	15 OF 26

#### 6.14 INTERFACE WITH EXISTING EXCHANGE:

PA system central exchange for the unit will be interfaced with existing/new EPABX/ PA System.

#### 6.15 OTHER

6.15.1 Locations in different zones for different type of handset stations and loudspeakers are indicated in Section – C.

6.15.2 Bidder shall furnish separately the power supply requirements (in watts) for both central exchanges along with different stations attached to each exchange to decide the feeder size.

6.15.3 Makes of equipment/ components shall be subject to purchaser's approval during detailed engineering. However, bidder shall furnish the list of makes along with the offer.

6.15.4 Three sets of hard as well soft copies (in pdf form) of dwg/ documents will be required for the purchaser's review/ approval.

6.15.5 After completion of work at site, bidder shall prepare "AS BUILT DRAWINGS" and "O&M Manuals" as per distribution list enclosed with Section – C.

#### 6.16 COMMON REQUIREMENTS OF VARIOUS EQUIPMENT OF SUPPLY

##### 6.16.1 Surface Treatment

##### 6.16.1.1 Painting:

- a) Pre-treatment: In the first step, complete surface shall be cleaned with sand paper and/ or cotton cloth to remove accumulated dust and dirt. Surface pre-treatment shall generally conform to IS: 6005. Pre-treated surface shall be provided with one coat of red oxide paint.
- b) Surface Finish: Two coats of abrasion resistant, anticorrosive synthetic enamel shall be applied on the pre-treated surface. Second coat shall be applied only when the first coat has completely dried-up. Surface finish after the painting shall be smooth, uniform and free from spots.
- c) Thickness of paint shall be 80 microns.

##### 6.16.1.2 COLOUR OF EQUIPMENT

Following colour paint shade shall be followed for different items. All painting shall be through powder coated epoxy base paint.

Central Exchange Interior and exterior	: As per project requirement
Any misc. item including wall mounted MDB in CCR/EER area	: As per project requirement
Field Stations, junction boxes, horn type speakers, extension amplifier and cone type speakers, Flush mounted, desktop and master stations	: As per project requirement /As per manufacture standard color shade
weather protecting canopy, acoustic hood ,MDB	: As per project requirement

##### 6.16.1.3 Galvanizing

- a) Pre-treatment: In the first step, complete surface shall be cleaned with sand paper and/ or cotton cloth to remove accumulated dust and dirt. Surface pre-treatment shall be done before galvanization, which shall conform to the requirements of IS: 6005.
- b) Surface-Finish: Articles shall be hot dip galvanized after fabrication, surface cleaning and pre-treatment. The galvanizing shall be done according to IS: 2629. The galvanizing shall be



TITLE

**Technical Specification  
for  
PUBLIC ADDRESS SYSTEM**

SPECIFICATION NO. PE-SS-999-557-E001

VOLUME II B

SECTION D

REV 01 DATE 23/03/2012

SHEET 16 OF 26

- c) uniform, clean, smooth, continuous and free from acid spots. If the galvanizing of the samples is found defective, the entire batch of steel will have to be regalvanized at vendor's cost.
- Weight and thickness of zinc deposited shall not be less than 610 gm/m<sup>2</sup> and 75 microns respectively. The purchaser reserves the right to measure the thickness of zinc deposit by an Elkometer or any other instrument acceptable to purchaser and reject any component, which shows thickness of zinc at any location to be less than the value specified.

#### 6.16.2 Labels

All components whether mounted inside or on the surface of the main equipment, shall have identifying references as per the arrangement drawings and wiring diagrams. The labels shall be of non-rusting metal or 3 ply lamicaid and shall have white inscriptions on black background. The label size shall be subject to the purchaser's approval.

#### 6.16.3 Earthing

6.16.3.1 Earthing of all sheet metallic parts of enclosures of all equipments covered in this specification which are non-current carrying shall be bonded to an earth stud provided in the equipment. The Contractor shall ensure that proper earthing terminals are provided in all equipment covered in this specification.

6.16.3.2 Earthing of cabling system: Armour of cables shall be earthed at both ends of cable.

For earthing of power supply cable, an additional core shall be provided or else a continuous ground conductor of 16 SWG GI wire shall be run along each conduit run.

6.16.3.3 The supply and installation of all earthing wires, earthing plates and other materials for earthing the entire PA System shall be under the scope of the Contractor. The Contractor shall properly earth the system so that there is no interference in the communication system due to electromagnetic noise.

#### 6.16.4 Packing

The material shall be packed as per manufacturer's standard to ensure the protection against mechanical damage, jerks, rain etc. during transit and for a prolonged period of storage. Packing procedure shall be subject to the purchaser's approval.

### 7.0 INSPECTION AND TESTING

#### 7.1 INSPECTION

7.1.1 The following stages of manufacture shall be stage inspected by Purchaser or his duly authorised representative.

- a) Inspection of manufacturing processes such as shearing, punching, bending, welding, galvanizing, painting etc.
- b) Inspection of finished products.
- c) Inspection of packing material and procedure.

7.1.2 All materials, components and equipments covered under this specification shall be procured, manufactured, inspected and tested as per the purchaser's standards and quality plan of vendor duly approved by purchaser.



TITLE

**Technical Specification  
for  
PUBLIC ADDRESS SYSTEM**

SPECIFICATION NO. PE-SS-999-557-E001

VOLUME II B

SECTION D

REV 01 DATE 23/03/2012

SHEET 17 OF 26

- 7.1.3 All material used for the construction of the equipment shall be new and shall be in accordance with the requirements of this specification. Materials utilized shall be those, which have established themselves for use in such applications.
- 7.1.4 All acceptance and routine tests as per relevant standards and specification shall be carried out by the manufacturer. Charges for all these routine and acceptance tests for all the materials shall be deemed to be included in the bid price.
- 7.1.5 Bidder shall prepare and submit along with the bid the quality plan on the prescribed format. Quality plan shall include details of quality control and testing at different stages of manufacture, testing of completely assembled items.
- 7.2 TESTING
- 7.2.1 Tests at Works
- 7.2.1.1 The supplier shall perform all tests necessary to ensure that the material and workmanship conform to the relevant standards and that such tests are adequate to demonstrate that the equipment will comply with the requirements of this specification. Copy of the standards/ test methods to which the tests will be conducted are to be furnished during detailed engineering stage.
- 7.2.1.2 Test certificates shall be submitted for purchaser's approval before despatch of the equipment. The purchaser may witness the test at supplier's works, for which sufficient advance notice shall be given before testing.
- 7.2.1.3 The following tests shall be conducted as acceptance tests at manufacturer's works:
- a) Printed Circuit Boards  
Following tests are to be performed on different PCBs and those shall also conform to approved Quality Plan:
    - i. Burn-in test for all PCBs (Routine test)
    - ii Climatic and Durability tests (Vibration, dry heat test, damp heat cycle, low temperature and transportation)
  - b) Amplifier & Handset
    - i. Rated output power
    - ii. Rated input voltage
    - iii. Power consumption
    - iv. Current drain
    - v. Harmonic distortion
    - vi. Input/ Output Impedance
    - vii. Insulation resistance
  - c) Speakers  
All the speakers shall be tested as per IS: 7741. Apart from these during assembly, the components like transistors, ICs, resistances, capacitors, switches, relays etc. shall be tested and a certificate shall be obtained from the manufacturer which may be verified by others.
  - d) Junction Boxes  
All junction boxes shall be checked for 100% IR, HV and dimensional checks.
  - e) Tests for painting  
The painting of articles shall meet the requirements of IS: 1477 (Part 1 & Part 2) in general.
  - f) Tests for galvanizing  
Weight, thickness and uniformity of zinc, coating shall be determined in accordance with IS: 6745 and IS: 2633 shall conform to the specification requirements.

	<p style="text-align: center;">TITLE</p> <p style="text-align: center;"><b>Technical Specification for PUBLIC ADDRESS SYSTEM</b></p>	SPECIFICATION NO.	PE-SS-999-557-E001
		VOLUME	II B
		SECTION	D
		REV 01	DATE 23/03/2012
		SHEET	18 OF 26

### 7.2.2 Site Tests

7.2.2.1 After assembly, all major equipment together are to be site tested to establish the workability of the system at site.

7.2.2.2 Following tests are to be performed at site:

- a) Insulation resistance, HV test for cables.
- b) Rated output power.
- c) Performance of PAGE and PRIVATE channels for all equipments in the entire Public Address System.
- d) Proper functioning of auto-changeover unit.
- e) Test to ensure that db level of announcement at any station by its own handset shall be lower than announcement at the same station by any other handset.

7.2.2.3 Bidder to perform all site tests as per the Field Quality Plan. During contract stage bidder to furnish details of these tests & the standards to which these conform for purchasers approval.

### 7.2.3 General Requirements of Site Testing

7.2.3.1 The Owner may ask for any tests at site which in his opinion are necessary to determine that the works comply with the specification, manufacturer's instruction or the applicable IS code of installation. The

Contractor shall be responsible for conducting the tests and shall bear the cost of such additional tests.

7.2.3.2 The contractor shall have to bring all testing equipment & instruments to carry out the job. All instruments shall be calibrated to the satisfaction of the Engineer before actual testing and tests shall be conducted by qualified & experienced personnel.

7.2.3.3 All documents/ records regarding test data and all other measured values shall be submitted to Engineer for approval and subsequent record and reference. The results of all tests shall conform to the specification requirements as well as any specific performance data guaranteed during finalisation of contract.

### 7.2.4 Type test

Type test reports should be furnished as per enclosed Annexure A of Quality plan.

## 9.0 PRICES

9.0.1 The bidder shall quote his prices for equipment of complete Public Address System, supply, as per BOQ format enclosed with Section – C.

9.0.2 The unit rates of supply for all equipment and service quoted by the bidder shall be firm for a variation of quantities limited to:

- a.  $\pm 20\%$  of total order value till finalisation of engineering details & BOQ.
- b.  $+10\%$  of the total order value in addition to (a) above, till the completion of job.

9.0.3 Purchaser reserves the right to delete/add any equipment or services from the bidder's scope and, for price adjustment in such cases, unit prices quoted by the bidder will be considered.

9.0.4 The bidder shall furnish unpriced "Price Schedule" of all equipment and services, as per BOQ along with the technical bid.



<b>TITLE</b>  <b>Technical Specification for PUBLIC ADDRESS SYSTEM</b>	SPECIFICATION NO.	PE-SS-999-557-E001
	VOLUME	II B
	SECTION	D
	REV 01	DATE 23/03/2012
	SHEET	19 OF 26

9.0.5 Bidder to note that the price for System Engineering Design shall form part of main equipment and will not vary with the change in scope of supply of equipment.

9.0 PERFORMANCE GUARANTEES

Bidder shall guarantee that the system offered shall meet the requirement as indicated in this specification and as confirmed by them in various clauses of technical data sheets. If it is proved that the system doesn't conform to performance guarantee, the bidder shall be ready to replace the faulty equipment/components at site without any extra cost.

10.0 INSTALLATION AND MAINTENANCE MANUAL

10.1 Instruction manuals for the installation, operation and maintenance of PA System shall be furnished before despatch of the equipment.

10.2 Draft manual shall first be submitted for Purchaser's approval. The manual shall contain minimum following details:

- a) General description of equipment
- b) Brief system description for which equipment is meant
- c) Technical data
- d) Salient constructional details
- e) Technical leaflets of important components used in the system
- f) All drawings
- g) Type and routine test certificates
- h) Instructions to be followed on receipt of equipment at site and for storage
- i) Material handling instructions
- j) Erection procedure and checks
- k) Pre-commissioning checks
- l) Commissioning procedures
- m) Operation instructions
- n) Maintenance instructions
- o) Trouble shooting
- p) Safety instructions

11.0 DOCUMENTATION

11.1 DOCUMENTS TO BE FURNISHED WITH THE BID

- a) Brief System Description.
- b) Filled and stamped Data Sheet B

11.2 DOCUMENTS TO BE FURNISHED BY THE VENDOR DURING DETAILED ENGINEERING STAGE

- a) Full description and design of the equipment and its operation.
- b) General arrangement drawings cum Technical Datasheet for various equipment as per drawing list.
- c) Detailed write up on the method of testing.
- d) Interconnection diagram showing the interconnection between main distribution board, master station(s), JB's, handsets, loud speakers covering the size of cable.
- e) Cable schedule
- f) Operation and maintenance (O&M) manual.
- g) Signed and stamped Standard Quality Plan.
- h) Minimum 3 copies of all test certificates for the tests actually conducted on the equipment



TITLE

Technical Specification  
for  
PUBLIC ADDRESS SYSTEM

SPECIFICATION NO. PE-SS-999-557-E001

VOLUME II B

SECTION D

REV 01 DATE 23/03/2012

SHEET 20 OF 26



TITLE

Technical Specification  
for  
PUBLIC ADDRESS SYSTEM

SPECIFICATION NO. PE-SS-999-557-E001

VOLUME II B

SECTION D

REV 01 DATE 23/03/2012

SHEET 21 OF 26

## Erection and Commissioning



TITLE

**Technical Specification  
for  
PUBLIC ADDRESS SYSTEM**

SPECIFICATION NO. PE-SS-999-557-E001

VOLUME II B

SECTION D

REV 01 DATE 23/03/2012

SHEET 22 OF 26

## CONTENTS

- 1.0 GENERAL
- 2.0 CODES AND STANDARDS
- 3.0 INSTALLATION
  - 3.1 PA SYSTEM EQUIPMENT INSTALLATION
  - 3.2 ITEMS OF SUPPLY FOR CABLING INSTALLATION WORK
  - 3.3 INSTALLATION OF CABLES AND CONDUITS
  - 3.4 ADDITIONAL POINTS OF CONSIDERATION
- 4.0 QUANTITY MEASUREMENT AND WASTAGE ALLOWANCE
  - 4.1 MEASUREMENT OF QUANTITIES
  - 4.2 CUTTING AND WASTAGE ALLOWANCE
- 5.0 TESTING
  - 5.1 SITE TESTS
  - 5.2 GENERAL REQUIREMENTS OF SITE TESTING
- 6.0 PRICES
  - 6.1 GENERAL
  - 6.2 UNIT PRICES OF INSTALLATION WORK



TITLE

**Technical Specification  
for  
PUBLIC ADDRESS SYSTEM**

SPECIFICATION NO. PE-SS-999-557-E001

VOLUME II B

SECTION D

REV 01 DATE 23/03/2012

SHEET 23 OF 26

**1.0 GENERAL**

The scope of this specification covers handling and storage at site; installation, testing and commissioning of Public Address System for efficient and trouble free operation after installing the same at site.

**2.0 CODES AND STANDARDS**

The installation shall comply with all currently applicable statutes, regulations and safety codes in the locality where the equipment will be installed. Nothing in this specification shall be construed to relieve the vendor of his responsibility.

**3.0 INSTALLATION**

The contractor shall carry out total installation work as per the requirements of the specification and instructions of Engineer.

**3.1 PA SYSTEM EQUIPMENT INSTALLATION**

3.1.1 Installation of PA System equipment shall include erection, connection, grounding, testing and commissioning of the equipment. Installation activity shall also include provision of all fittings, supports, hangers and other accessories which are not specifically mentioned but are required to complete the installation work.

3.1.2 Equipment shall be brought to the place of work only at the time of erection. Unpacking, handling, assembling and erection shall be as per the guidelines of installation manual and Field Quality Plan.

3.1.3 Erection shall commence in an area only after the clearance has been obtained from the Engineer. Vendor shall ensure that all activities, which are liable to damage the equipment in that area, have been completed.

3.1.4 The drilling and welding of building steel work for fixing supports and brackets shall not be done without the prior approval of Engineer.

3.1.5 Wherever drilling and welding of building steel work for fixing supports and brackets is done, the same shall be re-painted and restored to the same paint shade as per site requirement at no extra cost to purchaser.

**3.2 ITEMS OF SUPPLY FOR CABLING INSTALLATION WORK**

The supply of below listed items shall be considered to be part of cabling installation work:

**3.2.1 Cable glands**

Cable glands shall be single or double compression type. Material of glands shall be brass. Nickel plating shall be provided if indicated in Data Sheet A. Rubber components used in the gland shall be of neoprene. Name/ trade name of manufacturer, type no. and applicable range of outer diameter of cable shall be engraved/ printed on the cable gland.

**3.2.2 Cable lugs**

Cable lugs shall be of tinned copper. Name/ trade name and size shall be engraved/ printed on each cable lug.

**3.2.3 Self Locking Clamps**

Clamps shall be of nylon material having self-locking feature when the cord is looped. They shall be provided with manual lock release. Clamp cord shall not move in the backward direction once it has been locked, unless the lock release is depressed.

**3.2.4 Ferrules**

Ferrules shall be required for individual core of cables hence they shall be suitable for the insulated

	<b>TITLE</b>  <b>Technical Specification for PUBLIC ADDRESS SYSTEM</b>	<b>SPECIFICATION NO.</b> PE-SS-999-557-E001
		<b>VOLUME</b> II B
		<b>SECTION</b> D
		<b>REV</b> 01 <b>DATE</b> 23/03/2012
		<b>SHEET</b> 24 OF 26

conductor diameter. They shall be of plastic material. Numbering on the ferrules shall be engraved type. Colour of base shall be yellow and that of engraving shall be black. Engrave colouring shall be of durable quality to match the entire life of the plant. Engraving shall be legible from a distance of 600 mm. Ferrules shall be interlocked type such that the interlocked ferrules take the shape of tube with complete ferrule number marked in a straight line.

### 3.2.5 Tags

For identification, cables shall be provided with cable number tags of durable fibre, aluminium or stainless steel sheets. Cable numbers shall be engraved type in case of aluminium or stainless steel tags, and printed type in case of fibre sheet. Tags shall be of durable quality of size 60mm x 12mm with a tie hole at each end and shall be provided with non-corrosive wire of sufficient strength for tagging.

## 3.3 INSTALLATION OF CABLES AND CONDUITS

3.3.1 All cables shall be provided with identification tags indicating the cable numbers in accordance with the cable circuit schedule. Tags shall be fixed at both ends of cables and on both sides of floor/ wall crossings.

3.3.2 All cable entries in the equipment shall be sealed by cable glands.

3.3.3 Power cable terminations shall be carried out in such a manner as to avoid strain on the terminals by providing suitable clamps near the terminals.

3.3.4 Control cable cores entering the equipment or control panels shall be neatly bunched and strapped with PVC perforated tapes/ nylon ties and suitably supported to keep them in position at the terminal block. Copper conductor control cables shall be terminated directly into screw type terminals provided in the equipment.

3.3.5 Wherever control cables are to be terminated by means of terminal lugs, the same shall be of tinned copper compression type.

3.3.6 All spare cores shall be connected to spare terminals wherever possible. If spare terminals are not available, spare cores shall be neatly dressed and suitably taped at both ends.

3.3.7 Individual cores of control cables shall have ferrules for identification. Ferrule numbers shall be provided as per the control schemes and other related documents supplied by the purchaser.

## 3.4 ADDITIONAL POINTS OF CONSIDERATION

3.4.1 The installation work shall be carried out in a neat workman-like manner by skilled, experienced and competent workmen.

3.4.2 Installation shall be properly coordinated at site with other services and wherever necessary suitable adjustment shall be made to avoid interference with any part of the building, structures, equipment, utilities and services. Any such adjustment shall be done with the approval of Engineer.

3.4.3 All materials being supplied or consumed during erection by the vendor in the process of erection work shall be of the best quality and according to the relevant standards. All materials shall be got inspected and approved by the Engineer before the same is used for erection work.

3.4.4 Any work like chipping/ breaking of existing structure like walls, floors, fabrications, etc. shall be done after taking prior approval of Engineer.

3.4.5 Any wrong erection shall be removed & re-erected promptly to comply with the design requirements to the satisfaction of Engineer. Re-erection shall be done at no extra cost to the purchaser.

	TITLE	SPECIFICATION NO.	PE-SS-999-557-E001
	<p style="text-align: center;"><b>Technical Specification for PUBLIC ADDRESS SYSTEM</b></p>	VOLUME	II B
		SECTION	D
		REV 01	DATE 23/03/2012
		SHEET	25 OF 26

3.4.6 While testing and commissioning, if the system is observed to be not functioning, it shall be the responsibility of the contractor to check, rectify and demonstrate that the defect has been removed to the satisfaction of purchaser.

3.4.7 Before energisation of system, physical inspection shall be carried out and all foreign bodies shall be removed and loose connecting bolts etc. shall be tightened.

#### 4.0 QUANTITY MEASUREMENT AND WASTAGE ALLOWANCE

##### 4.1 MEASUREMENT OF QUANTITIES

4.1.1 For all payment purposes, measurement shall be made on the basis of the execution drawings/ physical measurements. Physical measurements shall be made by the contractor in the presence of the Engineer.

4.1.2 Wastage allowance shall be kept in consideration while making material appropriation of supplied items.

##### 4.2 CUTTING AND WASTAGE ALLOWANCE

Vendor shall carefully plan the cutting schedule of each cable drum such that wastages are minimised and any resultant short lengths can be used where appropriate route lengths are available.

#### 5.0 TESTING

##### 5.1 Site Tests

5.1.1 After assembly, all major equipment together are to be site tested to establish the workability of the system at site.

5.1.1.1 Following tests are to be performed at site:

- a) Insulation resistance, HV test for cables.
- b) Rated output power.
- c) Performance of PAGE and PRIVATE channels for all equipments in the entire Public Address System.
- d) Proper functioning of auto-changeover unit.
- e) Test to ensure that db level of announcement at any station by its own handset shall be lower than announcement at the same station by any other handset.

5.1.1.2 Bidder to perform all site tests as per the Field Quality Plan. During contract stage bidder to furnish details of these tests & the standards to which these conform for purchasers approval.

##### 5.2 General Requirements of Site Testing

5.2.2.1 The Owner may ask for any tests at site which in his opinion are necessary to determine that the works comply with the specification, manufacturer's instruction or the applicable IS code of installation. The Contractor shall be responsible for conducting the tests and shall bear the cost of such additional tests.

5.2.2.2 The contractor shall have to bring all testing equipment & instruments to carry out the job. All instruments shall be calibrated to the satisfaction of the Engineer before actual testing and tests shall be conducted by qualified & experienced personnel.

5.2.2.3 All documents/ records regarding test data and all other measured values shall be submitted to Engineer for approval and subsequent record and reference. The results of all tests shall conform to the specification requirements as well as any specific performance data guaranteed during finalisation of contract.



<b>TITLE</b>  <b>Technical Specification for PUBLIC ADDRESS SYSTEM</b>	<b>SPECIFICATION NO.</b>	PE-SS-999-557-E001
	<b>VOLUME</b>	II B
	<b>SECTION</b>	D
	<b>REV</b> 01	<b>DATE</b> 23/03/2012
	<b>SHEET</b>	26    OF    26

## 6.0 PRICES

### 6.1 GENERAL

Unit prices listed out in this clause shall be applicable for payment to the contractor for activities covered under this specification. The following shall be kept in consideration while quoting the prices:

### 6.2 UNIT PRICES OF INSTALLATION WORK

Detailed requirement for all the items are given in the specifications, Data Sheet A and Annexures.

- a) Unit price of installation shall include transportation of materials from Vendor's/ Owner's storage yard to work site, handling, testing before erection, testing after erection and commissioning of materials including supply and installation of all associated materials (including support materials) and consumables, carrying out of all associated minor civil works and furnishing of all skilled/ unskilled labour, supervisory and commissioning staff.
- b) Price of earth connections are to be included in the erection price of equipment as above.
- c) No separate prices shall be applicable for termination of cables. Cable termination shall include drilling of gland plates, fixing of glands, ferrules and lugs and connection to the equipment.
- d) Purchaser reserves the right to delete/ add any of the equipment or services from the bidder's scope of work.
- e) The unit prices quoted shall be for supply and/ or installation as explained in detail in the clauses in subsequent paragraphs. No other prices shall be applicable for the purpose of payment.
- f) While quoting the prices for installation, the following shall be considered as part of job:
  - i. Cable glands and lugs
  - ii. Clamps, ferrules, aluminium/ stainless steel tags as per the project requirements
  - iii. Fasteners like nuts, bolts, washers, spring washers, rawl plugs, anchoring bolts and lugs etc.
  - iv. Conduit plugs, gaskets, couplers, and insulated bushings
  - iv. Sealing compounds for wall and floor openings
  - v. Consumables like enamels, cold zinc paint, electrodes for welding etc.
  - vi. Materials for minor civil works
- g) The following shall be arranged by the contractor at no extra cost:
  - i. All unskilled and skilled labour
  - ii. All supervisory and commissioning staff
  - iii. All facilities/ equipment for site fabrication such as cutting, bending and drilling equipment
  - iv. Welding set(s)
  - v. Material handling equipment
  - vi. All special tools and tackles for erection
  - viii. All testing equipment
- h) Requirement of Quality Plan and Field Quality Plan shall be considered in the quoted prices.
- i) E & C spares required shall be part of E & C charges.
- j) Instruments required for testing & commissioning shall be arranged by the contractor and shall be taken back after E & C.
- k) Fabrication and painting of support structures of various equipments shall be in contractor's scope. However structural steel shall be free issue by BHEL.

# ***DATASHEET A***

	TITLE	SPECIFICATION NO.	PE-TS-405-557-E-001
	<b>PUBLIC ADDRESS SYSTEM</b>  <b>Datasheet A</b>	VOLUME	IIB
		SECTION	C
		REV 00	DATE 19.01.2015
		SHEET	1 OF 3

S No.	Description	Unit	Data (□ - not applicable / ■ - applicable)
<b>1.0</b>	<b>SYSTEM DESIGN DATA</b>		
1.1	Design ambient temperature	°C	50
1.2	Relative humidity		
a)	Average	%	refer project information
b)	Maximum	%	refer project information
<b>2.0</b>	<b>POWER SUPPLY</b>		
2.1	AC Normal Supply		
i.	Rated voltage	V	240V AC
ii.	Rated frequency	Hz	50Hz
iii.	Voltage variation	%	±10%
iv.	Frequency variation	%	+3% & -5%
v.	Combined voltage & frequency variation (sum of absolutes)	%	10%
2.2	AC UPS		
i.	Rated voltage	V	240V AC
ii.	Rated frequency	Hz	50Hz
iii.	Voltage variation	%	±10%
iv.	Frequency variation	%	+3% & -5%
v.	Combined voltage & frequency variation (sum of absolutes)	%	10%
<b>3.0</b>	<b>EARTHING</b>		
3.1	Type		
3.2	Size	mm	
3.3	Type of power cable for earthing		□ Additional core    ■ GI wire
<b>4.0</b>	<b>SYSTEM REQUIREMENTS</b>		
4.1	Frequency response	Hz	400-6000Hz (±3 dB)
<b>5.0</b>	<b>CENTRAL EXCHANGE</b>		
5.1	Capacity (Main area & CHP area)	Lines	176 (Main exchange )& 80 (CHP sub-exchange)
5.2	Frequency response	Hz	200-10000Hz (±10 dB)
5.3	Rated voltage / frequency		240V 50Hz AC UPS
5.4	Central Exchange Interior and exterior paint		Shall be decided during detailed engg.
5.5	Any misc. item		Integrated MDF/MDB
5.6	Degree of protection		IP-22
5.7	Material		MS, 2mm thick minimum
<b>6.0</b>	<b>MASTER / DESK TOP STATION</b>		
6.1	Type of protection		Electronic circuit protection
6.2	Material		high impact polystyrene or equivalent /ABS plastic/CRCA sheet
6.3	Colour		Shall be decided during detailed engg.
6.4	Degree of protection		IP-32 min
<b>7.0</b>	<b>HAND SET STATION</b>		
7.1	Gain	dB	50 dB
7.2	Microphone		
	Type		Noise cancelling type
	Frequency response	Hz	200- 7000Hz (±3 dB)
7.3	Receiver type		High efficiency dynamic type



TITLE  <b>PUBLIC ADDRESS SYSTEM</b>  <b>Datasheet A</b>	SPECIFICATION NO.	PE-TS-405-557-E-001
	VOLUME	IIB
	SECTION	C
	REV 00	DATE 19.01.2015
	SHEET	2 OF 3

S No.	Description	Unit	Data (□ - not applicable / ■ - applicable)
7.4	Enclosure material, thickness		■ Al (3 mm) ■ FRP (4 mm) ■ PVC (3 mm) ■ high impact polystyrene or equivalent
7.5	Degree of protection		IP-55 for main plant area. IP-65 for CHP area
7.6	Paint shade		Shall be decided during detailed engg.
7.7	Type of mounting		Wall / column mounting
<b>8.0</b>	<b>AMPLIFIER</b>		
8.1	Class		Class-B push-pull type
8.2	Frequency response	Hz	200 -10000 Hz (±3 dB)
8.3	Total harmonic distribution at 1000 Hz	%	Not more than 1%
8.4	Signal to noise ratio	dB	60dB
8.5	Supply voltage	Volt	240 V AC
8.6	Enclosure material, thickness		Aluminium, 3 mm
8.7	Degree of protection		IP-55
8.8	Paint shade		Shall be decided during detailed engg.
<b>9.0</b>	<b>HORN TYPE LOUD SPEAKER</b>		
9.1	Power Handling capacity	Watts	15 watts (rms) minimum
9.2	Frequency response	Hz	500-4500 Hz (±3 dB)
9.3	Sound pressure level at 1k Hz at 1Mtr	dB	102 Db (min)
9.4	Bell diameter		10 inch minimum
9.5	Enclosure material		18 SWG Aluminium (Spin)
9.6	Degree of protection		IP-55 for main plant area , IP-65 for CHP area
9.7	Paint shade		Shall be decided during detailed engg.
<b>10.0</b>	<b>CONE TYPE LOUD SPEAKER</b>		
10.1	Power Handling capacity	Watts	4 watts (rms) minimum
10.2	Frequency response	Hz	200-7000 Hz (±3 dB)
10.3	Sound pressure level at 1k Hz at 1Mtr	dB	84 dB (min)
10.4	Enclosure material		16 SWG MS sheet (Spin)
10.5	Degree of protection		IP-52
10.6	Paint shade for all areas		Shall be decided during detailed engg
10.7	Paint shade for CCR/EER		Shall be decided during detailed engg
<b>11.0</b>	<b>JUNCTION BOX(POWER/SIGNAL)</b>		
11.1	Degree of protection		IP-55 for indoor & IP-65 for outdoor
11.2	Enclosure material & thickness		■ FRP, 4MM
11.3	Paint shade		RAL 7305
<b>12.0</b>	<b>POWER DISTRIBUTION BOX</b>		
12.1	Capacity		2 inputs( Auto change over switch) & 32 outputs
12.2	Enclosure material		16 SWG MS Sheet
12.3	Degree of protection		IP-55
12.4	Paint shade		As per manufacturer's standard practice
12.5	Paint finish		Powder coated, textured
12.6	MCB provided		■ YES □ No
<b>13.0</b>	<b>Signal Loop Length</b>		
13.1	Unit area	km	4
13.2	CHP/LHS area	km	8
13.3	Common area	km	7
<b>14.0</b>	<b>Scope</b>		
14.1	Cables		Free issue by BHEL
14.2	Conduits		Free issue by BHEL



TITLE  <b>PUBLIC ADDRESS SYSTEM</b>  <b>Datasheet A</b>	SPECIFICATION NO.	PE-TS-405-557-E-001
	VOLUME	IIB
	SECTION	C
	REV 00	DATE 19.01.2015
	SHEET	3 OF 3

S No.	Description	Unit	Data ( <input type="checkbox"/> - not applicable / <input checked="" type="checkbox"/> - applicable)
14.3	Cable trays and support structure	BHEL	
<b>15.0</b>	<b>Type Tests</b>		
15.1	Type tests to be conducted for this contract, despite availability of valid & acceptable test certificates	<input type="checkbox"/> Yes	<input checked="" type="checkbox"/> No (Type test certificate should be furnished )
15.2	If yes, list of type tests to be conducted		
16.0	Special tools & tackles		
16.1	Special tools & tackles to be quoted for this contract		
	<input checked="" type="checkbox"/> Yes <input type="checkbox"/> No		
16.2	If yes, list of Special tools & tackles	Bidder to furnish the list	



TITLE

**3 X 660 MW NORTH KARANPURA STPP  
PUBLIC ADDRESS SYSTEM**

SPECIFICATION NO. PE-TS-405-557-E-001

VOLUME IIB

SECTION D

REV 0 DATE 19.01.2015

SHEET 1 OF 1

## ANNEXURE I OF DATASHEET A

**List of applicable codes & standards**

- 1.0 The equipment covered under this specification shall be designed, constructed and tested in accordance with latest revisions of applicable codes/ standards.
- 2.0 The equipments furnished under this specification shall conform to the latest revisions of the following standards.
- |                           |  |
|---------------------------|--|
| IS10426                   | PA System amplifiers-recommendations for minimum performance requirements and PA System amplifiers-recommendations for general requirements. |
| IS1882                    | PA system-code of practice for out door installations.   |
| IS1881                    | Indoor amplifying and sound reinforcement system-code of practice for installation.  |
| IS1031                    | Method of measurements on loudspeaker and loud speakers systems.   |
| IS2382                    | Recommended mounting dimensions of loud speakers.  |
| IS9302                    | Characteristics and Methods of Measurement for sound System equipment.   |
| IS616                     | Code of safety requirement for mains operated electronic and related apparatus.  |
| IS7741(Part-I,II and III) | Specification for loudspeaker.   |
| IS9000                    | Basic environmental testing procedures for electric and electronic items.  |
| IS2147                    | Degree of protection provided by enclosures for low voltage switchgear and control gear.   |
| IS9537(Part-I and II)     | Specification for conduits for Electrical (Part-I, II) installation/wiring.  |
| IS:1301                   | Code of safety requirement for electric mains operated audio amplifiers  |
| IS:1982                   | Code of practice for outdoor installation of PA system   |
| IS:732                    | Code of practice of electrical wiring installations (System voltage not exceeding 650 volts)   |
| IS:2667                   | Fittings for rigid steel conduits for electrical wiring  |

The system shall be adequately protected from signal and power line noise and meet the Surge Withstand Capability (SWC) requirements of ANSI C37.90 A/IEEE standard 472-1989 or equivalent.

# ***DATASHEET C***



TITLE <b>3 X 660 MW NORTH KARANPURA STPP</b> <b>PUBLIC ADDRESS SYSTEM</b> <b>Datasheet C</b>	SPECIFICATION NO.	PE-TS-405-557-E-001
	VOLUME	IIB
	SECTION	D
	REV 0	DATE 19.01.2015
	SHEET	1 OF 6

S.NO.	DESCRIPTION	PARTICULARS	UNIT
1.0	SYSTEM DESIGN DATA		
1.1	Design ambient temperature	:	°C
2.0	APPLICABLE STANDARDS		
2.1	Whether all standards specified in Annexure I of Data Sheet A followed	: <input type="checkbox"/> Yes <input type="checkbox"/> No	
3.0	COMPLETE SYSTEM REQUIREMENTS		
	a) Frequency response	:	Hz
	b) Hum & noise level or signal to noise level	:	
4.0	SCOPE OF SYSTEM DESIGN ENGINEERING	: <input type="checkbox"/> Included <input type="checkbox"/> Excluded	
5.0	POWER SUPPLY		
5.1	Whether the system suitable for operation for power supply details given in specification and Data Sheet A.	: <input type="checkbox"/> Yes <input type="checkbox"/> No	
5.2	Power supply requirement at 240V AC	:	kVA
6.0	CONSTRUCTIONAL REQUIREMENTS		
6.1	AMPLIFIERS (To be furnished separately for each type of amplifier)	: Pre-Amplifier    Line Amplifier    Loud Speaker Amplifier	
	a) Name of the manufacturer	:	
	b) Type and manufacturer's catalogue no.	:	
	c) Power supply details	:	
	d) Full load consumption(VA)	:	
	e) Rated load/ (W/Ohm) output impedance	:	
	f) Max. ambient conditions	:	
	g) Output voltage (V)	:	
	h) Frequency response (Hz)	:	
	i) Total harmonic (%)	:	
	j) Noise level (db)	:	
	k) Power band width (Hz)	:	
	l) Construction	:	
	m) Controls provided	:	
	i. Cont. variable	: <input type="checkbox"/> Yes <input type="checkbox"/> No	



<b>TITLE</b> <b>3 X 660 MW NORTH KARANPURA STPP</b> <b>PUBLIC ADDRESS SYSTEM</b> <b>Datasheet C</b>	<b>SPECIFICATION NO.</b>	PE-TS-405-557-E-001
	<b>VOLUME</b>	IIB
	<b>SECTION</b>	D
	<b>REV</b> 0	<b>DATE</b> 19.01.2015
	<b>SHEET</b>	2 OF 6

S.NO.	DESCRIPTION	PARTICULARS	UNIT
	volume control ii. Standby and idle time power supply cut-off arrangement arrangement iii. Bass & treble control n) Sensitivity w.r.t. (mV) nominal output o) Output connections p) Indications	: [ ] Yes [ ] No : [ ] Yes [ ] No : : :	
6.2	<b>HANDSETS</b>		
6.2.1	<b>Master Handset Station(s)</b> a) Name of the manufacturer b) Type and manufacturer's catalogue no. c) Material d) Degree of protection e) Surface treatment f) Whether all features provided on master handset station as per specification requirements g) Type of circuit protection h) Mounting arrangement i) Dimensions (L*D*H) j) Weight	: : : : : : [ ] Yes [ ] No : : : :	mm kg
6.2.2	<b>HANDSETS (To be furnished            separately for each type)</b>	<b>Outdoor/            Indoor            Wall mtd</b>	<b>Indoor            desk mtd</b>
	a) Name of the manufacturer b) Type and manufacturer's catalogue no. c) Material d) Impedance of the transmitter e) Frequency response of the transmitter f) Impedance of the receiver g) Receiver output h) Receiver frequency response i) Details of provision for noise cancellation features j) Details of provision for directional features k) Whether all features provided on handset	: : : : : : : : : : : [ ] Yes [ ] No	Ohm Hz Ohm mV Hz



<b>TITLE</b> <b>3 X 660 MW NORTH KARANPURA STPP</b> <b>PUBLIC ADDRESS SYSTEM</b> <b>Datasheet C</b>	<b>SPECIFICATION NO.</b>	PE-TS-405-557-E-001
	<b>VOLUME</b>	IIB
	<b>SECTION</b>	D
	<b>REV</b> 0	<b>DATE</b> 19.01.2015
	<b>SHEET</b>	3 OF 6

S.NO.	DESCRIPTION	PARTICULARS	UNIT
	station as per specification requirements		
	l) Degree of protection	:	
	m) Surface treatment	:	
	n) Mounting	:	
	o) Dimension with control box (L*D*H)	:	mm
	p) Weight	:	kg
6.3	LOUDSPEAKERS (To be furnished separately for each type)	Reentrant	Cone
	a) Name of the manufacturer	:	
	b) Type and manufacturer's catalogue no.	:	
	c) Material	:	
	d) Degree of protection	:	
	e) Surface treatment		
	i. Exterior surface	:	
	ii. Interior surface	:	
	f) Impedance matching volts (Transformer details)	:	Ohm
	g) Output power		
	i. rms	:	Watt
	ii. Peak	:	Watt
	h) Frequency response	:	Hz
	i) Cut-off frequency	:	Hz
	j) Sound level at 1000 Hz db/watt mtr. distance	:	
	k) Controls provided	:	
	l) Bell diameter	:	mm
	m) Acoustic length	:	mm
	n) Dispersion angle	:	Deg.
	o) Speaker diameter	:	mm
	p) Weight	:	kg
6.4	MAIN DISTRIBUTION BOX		
	a) Name of the manufacturer	:	
	b) Type	:	
	c) Construction	:	
	d) Material	:	
	e) Sheet steel thickness	:	mm
	f) Number of ways	:	
	g) Degree of protection	:	
	h) Surface treatment	:	
	i) Dimensions (L*D*H)	:	mm
6.5	JUNCTION BOX (to be furnished separately for each type)	JB-1 JB-2	JB-3
	a) Name of the manufacturer	:	
	b) Type	:	
	c) Construction	:	
	d) Material	:	



<b>TITLE</b> <b>3 X 660 MW NORTH KARANPURA STPP</b> <b>PUBLIC ADDRESS SYSTEM</b> <b>Datasheet C</b>	<b>SPECIFICATION NO.</b>	PE-TS-405-557-E-001
	<b>VOLUME</b>	IIB
	<b>SECTION</b>	D
	<b>REV</b> 0	<b>DATE</b> 19.01.2015
	<b>SHEET</b>	4 OF 6

S.NO.	DESCRIPTION	PARTICULARS	UNIT
	e) Sheet steel thickness	:	mm
	f) Number of ways	:	
	g) Degree of protection	:	
	h) Surface treatment	:	
	i) Dimensions (L*D*H)	:	mm
6.6	<b>COMMON REQUIREMENTS OF VARIOUS EQUIPMENTS</b>		
6.6.1	<b>Surface Treatment</b>		
	a) If painted;		
	i. Application	:	
	ii. Colour of paint		
	1. Inside	:	
	2. Outside	:	
	iii. Minimum thickness	:	microns
	b) If galvanized;		
	i. Method	:	
	ii. Applicable Standard	:	
	iii. Minimum thickness of zinc deposit on all points	:	microns
	iv. Weight of zinc	:	g/m <sup>2</sup>
6.6.2	<b>Labels</b>		
	a) Material	:	<input type="checkbox"/> Anodised Aluminium <input type="checkbox"/> Stainless Steel
6.6.3	<b>Earthing</b>		
	a) Name of the manufacturer	:	
	b) Type	:	
	c) Size	:	mm
	d) Details of earthing arrangement	:	
7.0	<b>OTHER MAJOR EQUIPMENTS OF SUPPLY</b>		
7.1	<b>CABLES (To be furnished separately for each type of cable)</b>		
7.1.1	<b>Applicable Standard</b>		
	IS:1554 Part 1 & IS:694 (In general)	:	<input type="checkbox"/> Yes <input type="checkbox"/> No
7.1.2	<b>Name of the manufacturer for</b>		
	a) Power cable	:	
	b) Signal cable	:	
	c) Loud Speaker cable	:	
7.1.3	<b>Whether FRLS type cable provided for</b>		
	a) Power cable	:	<input type="checkbox"/> Yes <input type="checkbox"/> No



<b>TITLE</b> <b>3 X 660 MW NORTH KARANPURA STPP</b> <b>PUBLIC ADDRESS SYSTEM</b> <b>Datasheet C</b>	<b>SPECIFICATION NO.</b>	PE-TS-405-557-E-001
	<b>VOLUME</b>	IIB
	<b>SECTION</b>	D
	<b>REV</b> 0	<b>DATE</b> 19.01.2015
	<b>SHEET</b>	5 OF 6

<b>S.NO.</b>	<b>DESCRIPTION</b>	<b>PARTICULARS</b>	<b>UNIT</b>
	b) Signal & loud speaker cable	: [ ] Yes [ ] No	
7.1.4	Voltage Grade for		
	a) Power cable	:	Volts
	b) Signal & loud speaker cable	:	Volts
7.1.5	Conductor		
	a) Material		
	i. Power cable	:	
	ii. Signal & loud speaker cable	:	
	b) No. of pairs/cores, conductor cross sectional area, no. of strands and dia. of each strand for		
	i. Power cable	:	
	ii. Signal cable	:	
	iii. Loud Speaker cable	:	
7.1.6	Insulation		
	a) Material	:	
	b) Application	:	
	c) Volume resistivity	:	
7.1.7	Identification of cores/pairs		
	a) Power cables, Control cables upto 5 core & Paired cables	:	
	b) Control cables above 5 core	:	
7.1.8	Paired cables		
	a) Min. number of twists per metre for paired cables	:	
7.1.9	Inner sheath		
	a) Material	: [ ] Type ST1 [ ] Type ST2	
	b) Whether FRLS	: [ ] Yes [ ] No	
	c) Fillers provided	:	
	d) Material of filler	:	
	e) Method of application		
	i. with fillers	: [ ] Pressure Extruded [ ] Vacuum Extruded	
	ii. without fillers	:	
7.1.10	Armour	:	
7.1.11	Outer sheath		
	a) Material	: [ ] Type ST1 [ ] Type ST2	
	b) Application	:	
	c) Colour	:	



<b>TITLE</b> <b>3 X 660 MW NORTH KARANPURA STPP</b> <b>PUBLIC ADDRESS SYSTEM</b> <b>Datasheet C</b>	SPECIFICATION NO.	PE-TS-405-557-E-001
	VOLUME	IIB
	SECTION	D
	REV 0	DATE 19.01.2015
	SHEET	6 OF 6

S.NO.	DESCRIPTION	PARTICULARS	UNIT
7.1.12	Characteristics of FRLS sheath a) Oxygen index (min.) b) Temp. index (min.) c) Acid gas generation (max.) d) Smoke density rating (max.)	: : : :	
7.1.13	Progressive sequential length marking provided on outer sheath	: <input type="checkbox"/> Yes <input type="checkbox"/> No	
7.2	<b>CONDUITS</b> a) Name of the manufacturer b) Type c) Gauge d) Size	: : : :	mm
7.3	<b>ITEMS OF SUPPLY FOR CABLING INSTALLATION WORK</b>		
7.3.1	Cable Glands a) Type b) Whether Nickel plating done	: <input type="checkbox"/> Single compression <input type="checkbox"/> Double compression : <input type="checkbox"/> Yes <input type="checkbox"/> No	
8.0	<b>DOCUMENTATION</b> Whether following documents enclosed :		
	a) Full description and design of the equipment and its operation.	: <input type="checkbox"/> Yes <input type="checkbox"/> No	
	b) Dimensional and mounting details of all equipments.	: <input type="checkbox"/> Yes <input type="checkbox"/> No	
	c) General arrangement drawings for handset station (all types), loud speakers (all types), JB's, Auto changeover Box, distribution box etc.	: <input type="checkbox"/> Yes <input type="checkbox"/> No	
	d) Auto changeover switching scheme.	: <input type="checkbox"/> Yes <input type="checkbox"/> No	
	e) Bill of quantities of cables, JB boxes, conduits etc.	: <input type="checkbox"/> Yes <input type="checkbox"/> No	
	f) Detailed write up on the method of testing.	: <input type="checkbox"/> Yes <input type="checkbox"/> No	
	g) Copies as specified in Section C of all test certificates for the tests actually conducted on the equipment.	: <input type="checkbox"/> Yes <input type="checkbox"/> No	
	h) Final Quality Plan (enclosed in Vol III)	: <input type="checkbox"/> Yes <input type="checkbox"/> No	
	i) Field quality plan	: <input type="checkbox"/> Yes <input type="checkbox"/> No	