

THE INFORMATION ON THIS DOCUMENT IS THE PROPERTY OF BHARAT HEAVY ELECTRICALS LIMITED.
IT MUST NOT BE USED DIRECTLY OR INDIRECTLY IN ANY WAY DETRIMENTAL TO THE INTEREST OF THE COMPANY.

INVENTORY NO.	SIGN. AND DATE	REF. DRG. NO.
---------------	----------------	---------------

REV.	DATE	ALTERED	REV.	DATE	ALTERED
ZONE		CHECKED	ZONE		CHECKED

		BHARAT HEAVY ELECTRICALS LTD. HYDERABAD	
DEPT. TITLE GRADE OF TDR DIM. C/M/F		SCALE WEIGHT(KG)	
SA HOUSING		SA HOUSING	
DSN NAME A1	SIGN. 	DATE 07.02.15	NO. OF VARS. 01
CNO APPD MMRAO	REF. TO RD DG 4 35 0520 6600	DATE 15.02.15	NO. OF ITEMS 01
CARD CODE RD DG 4 35 0520 6600	DRAWING NO. RD DG 4 35 0520 6600	SHEET NO.	NO. OF SHEETS

ITEM NO.	DESCRIPTION	DRAWING NO.	VAR.	ITNO.	MATL. CODE	A	UNIT WT.	QTY.	NON
02	DISH ASSY	RD DG 4 35 0520 6620			SS-304L	01			
01	SA ENCLOSURE	RD DG 4 35 0520 6610			SS-304L	01			

TYPE OF PRODUCT
NAME OF CUSTOMER
GSM-245

THE INFORMATION ON THIS DRAWING IS THE PROPERTY OF BHARAT HEAVY ELECTRICALS LIMITED.
 IT MUST NOT BE USED DIRECTLY OR INDIRECTLY IN ANY WAY DETRIMENTAL TO THE INTEREST OF THE COMPANY.

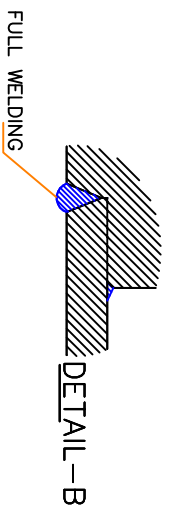
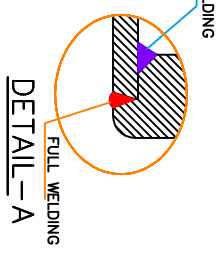
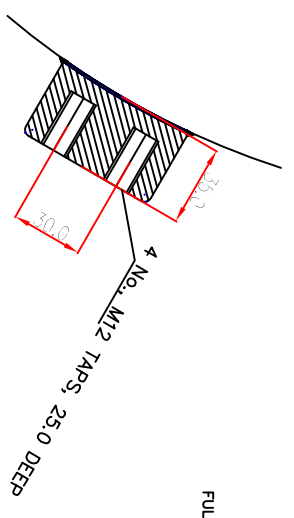
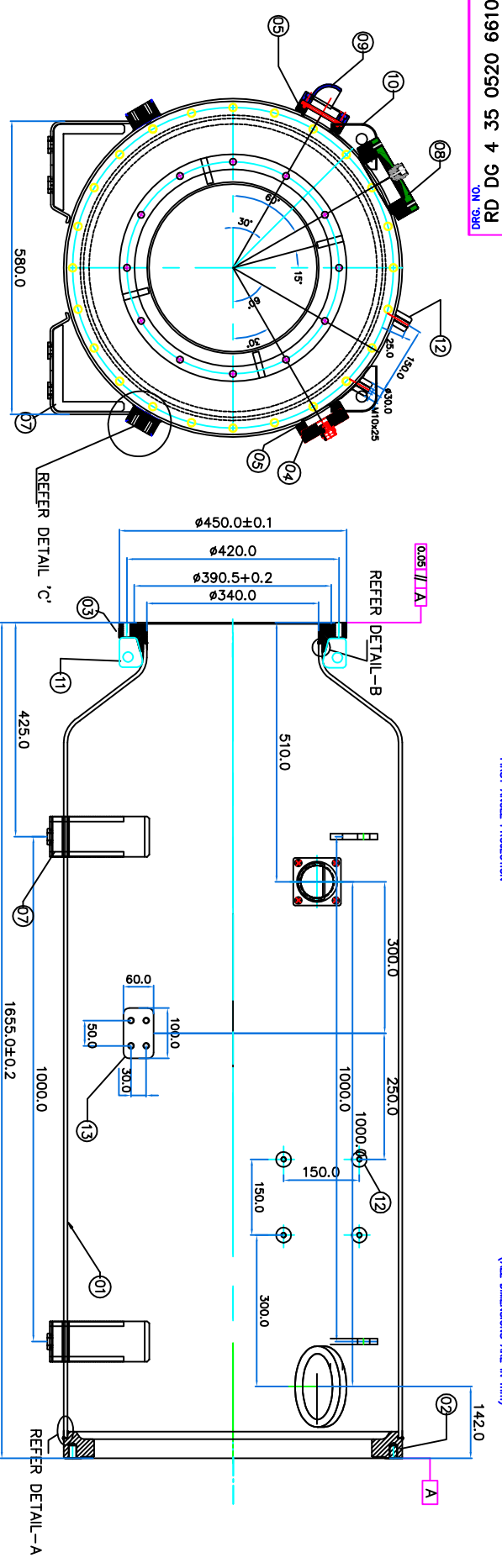

Note:

DETAIL - C

1. FLANGE TO BE TIG / MIG WELDING WITH SUITABLE SS ELECTRODE
2. THE ROOT SHOULD BE HOMOGENEOUS AND CONTINUOUS.
3. PRESSURE TEST AS PER ENCLOSED SPECIFICATION.
4. TESTED ASSEMBLIES TO BE DEGREASED, SAND BLASTED AND POWDER COATED ON OUTSIDE.
5. ELECTRO POLISH INSIDE SURFACE.
6. LIFTING LUGS AND SUPPORT BRACKETS SHALL BE FULLY WELDED TO PIPE AND FLANGE.
7. ALL WELDINGS SHALL BE GROUNDED TO DIMENSIONS.
8. FLANGES SHALL BE MACHINED TO DRAWING AFTER WELDING TO PIPE.

ITEM NO.	DESCRIPTION	QTY	UNIT	WT.	MATERIAL	ITEM NO.	DESCRIPTION	QTY	UNIT	WT.	MATERIAL
13	EARTHING PLATE	02			100X60X35	01	PIPE	01			RD DG 4 35 0520 6611
12	GUIDE RODS	01			25X30.0	02	FLANGE - I	01			RD DG 4 35 0520 6612
11	LIFTING LUG - I	04			RD DG 4 35 0520 6614	03	FLANGE - II	01			RD DG 4 35 0520 6613
10	LIFTING BRACKET	04			RD DG 4 35 1133 4140	04	DUMMY FLANGE	01			RD 99 320 640
09	RUPTURE DISK COVER	01			RD 99 320 630	05	FLANGE IV	02			RD 99 320 610
08	FLANGE V	01			RD DG 4 35 0617 983	06	FLANGE III	01			RD DG 4 35 1133 4160
07	SUPPORT BRACKET ASSY.	04			RD DG 4 35 1133 4130	07	FLANGE - I	01			RD DG 4 35 0520 6612

GSM-245

TYPE OF PRODUCT: NAME OF CUSTOMER: **BHARAT HEAVY ELECTRICALS LTD. HYDERABAD**

DEPT: **ENGINEERING** SCALE: **1:1** WEIGHT(KG):

DATE: 15.02.15

APPD: **MMRAO** REF. TO: **RD DG 4 35 0520 6600**

TITLE: **SA ENCLOSURE**

CARD CODE: **RD DG 4 35 0520 6610**

SHEET NO. **1** NO. OF SHEETS **1**

INVENTORY NO.	SIGN. AND DATE	REF. DRG. NO.
---------------	----------------	---------------

REV.	DATE	ALTERED	CHECKED	ZONE

REV.	DATE	ALTERED	CHECKED	ZONE

REV.	DATE	ALTERED	CHECKED	ZONE

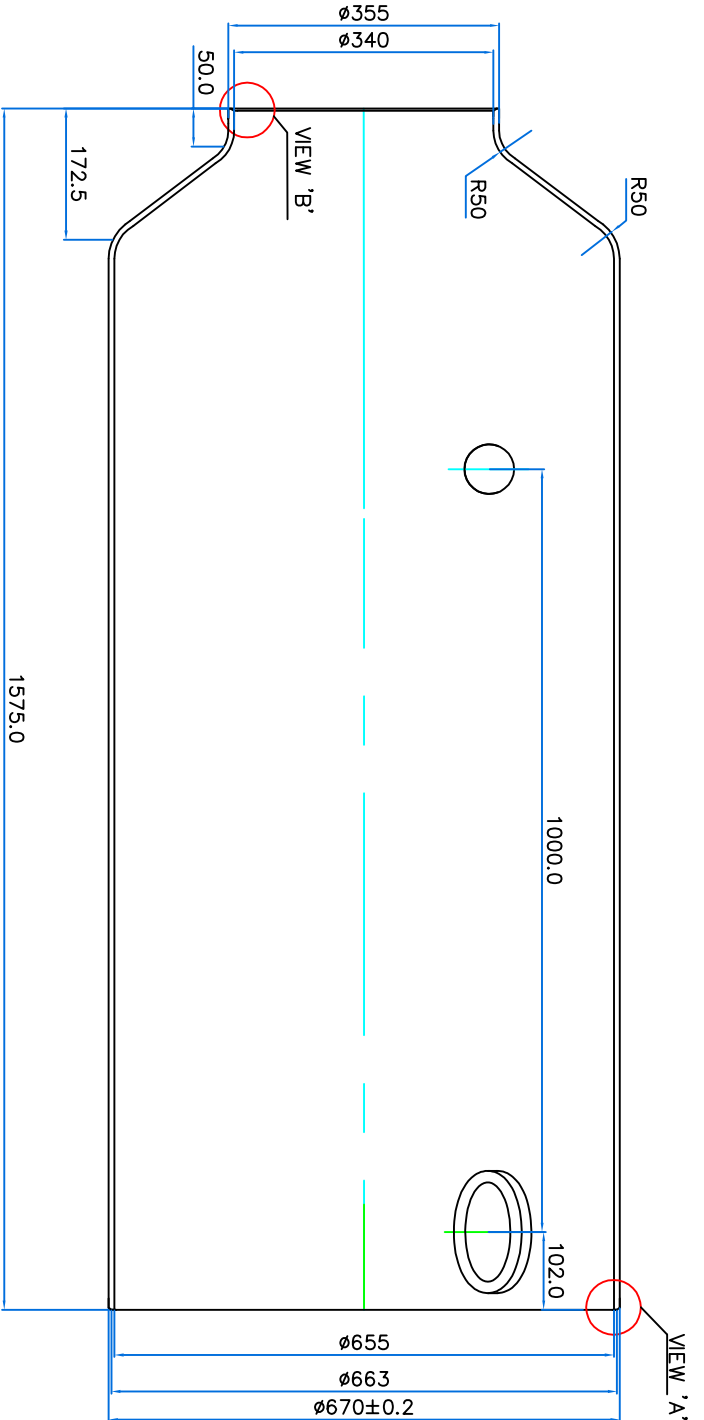
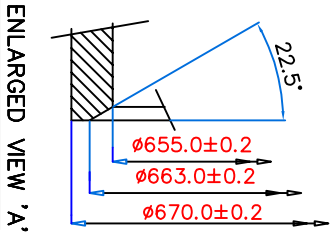
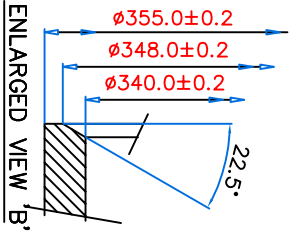
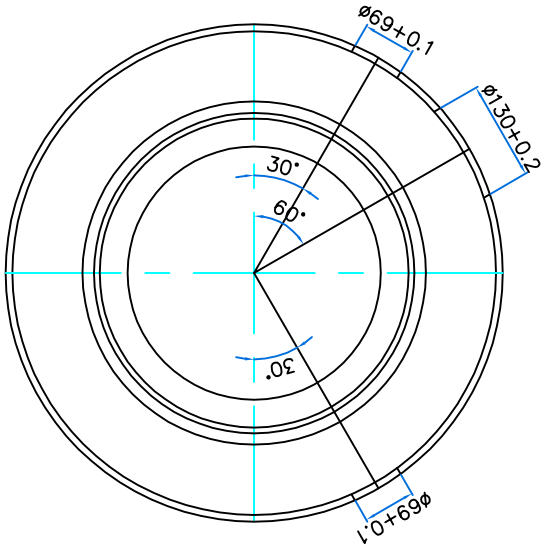

VAR. NO.	REMARKS	VAR. NO.	ITEM NO.	DESCRIPTION	QTY.	ZONE
		1		PIPE	1	

TYPE OF PRODUCT
NAME OF CUSTOMER
GSM-245

DEPT. CODE	GRADE OF TOL. DIM. C/M/F	SCALE	WEIGHT(KG)	DRAWING NO.	REF. TO
				RD DG 4 35 0520 6611	RD DG 4 35 0520 6600

DRN. NAME	SIGN.	DATE	NO. OF VARS.
AL		15.02.15	
MMRRAO		15.02.15	

REV.	DATE	ALTERED	ZONE	REV.	DATE	ALTERED	ZONE
		CHECKED				CHECKED	

CARD CODE	DRAWING NO.	SHEET NO.	NO. OF SHEETS
RD DG 4 35 0520 6611			

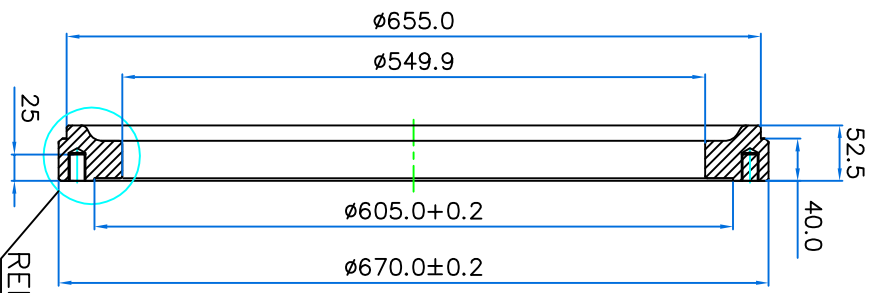
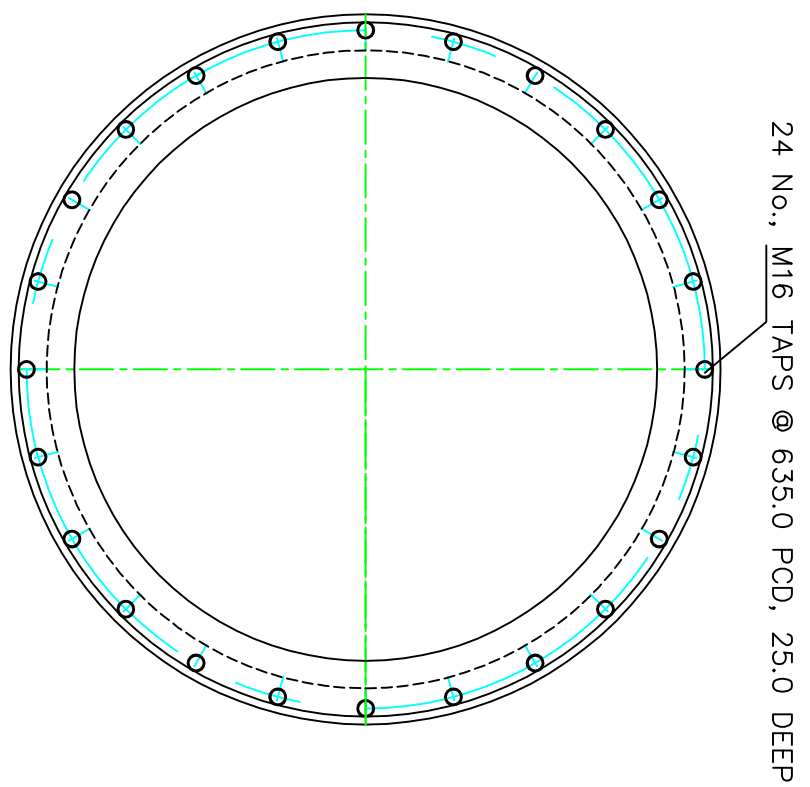

REFER DETAIL 'A'

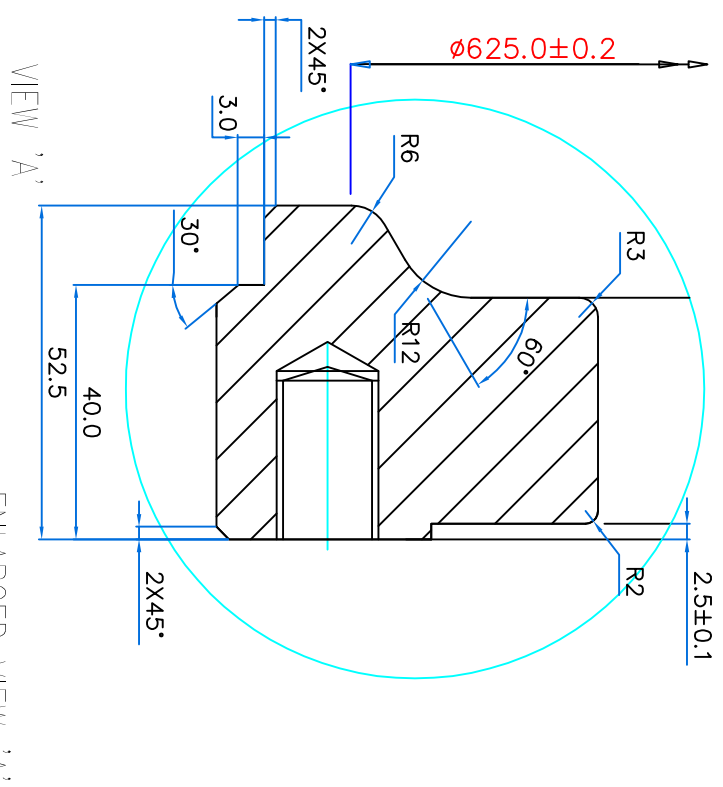

- Note:**
1. Sealing area shall be polished to RA 0.8 or better.
 2. M 16.0 Taps shall be chamfered uniformly (0.8x45°).
 3. PCD and flange centre shall be concentric within ±0.05
 4. Finished flange shall be degreased and packed in 125 micron poly bag and sealed.
 5. Component shall be Machined to dimensions after welding to pipe

VAR. CD	REMARKS	VAR. NO.	ITEM NO.	DESCRIPTION	DRAWING NO.	IT. NO.	MATL. CODE	A	UNIT WGT.	QTY.	ZONE
		01		BLOCK			SS-304L			01	

TYPE OF PRODUCT
NAME OF CUSTOMER
GSM-245

DEPT. CODE
GRADE OF TOL. DIM. C/M/F

SCALE

WEIGHT(KG)

APPRO. MARRAO
REF. TO RD DG 4 35 0520 6610

DATE 15.02.15

NO. OF SHEETS

REV.	DATE	ALTERED CHECKED	REV.	DATE	ALTERED CHECKED	TITLE	CARD CODE	SHEET NO.	NO. OF SHEETS
						FLANGE I	RD DG 4 35 0520 6612		

THE INFORMATION ON THIS DOCUMENT IS THE PROPERTY OF BHARAT HEAVY ELECTRICALS LIMITED.
IT MUST NOT BE USED DIRECTLY OR INDIRECTLY IN ANY WAY DETRIMENTAL TO THE INTEREST OF THE COMPANY.

INVENTORY NO.	SIGN. AND DATE	REF. DRG. NO.
---------------	----------------	---------------

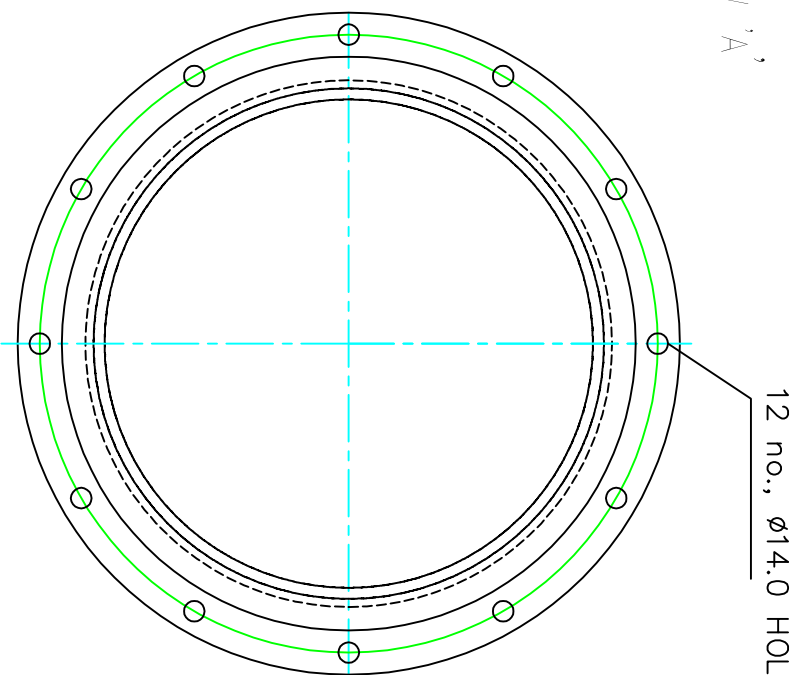
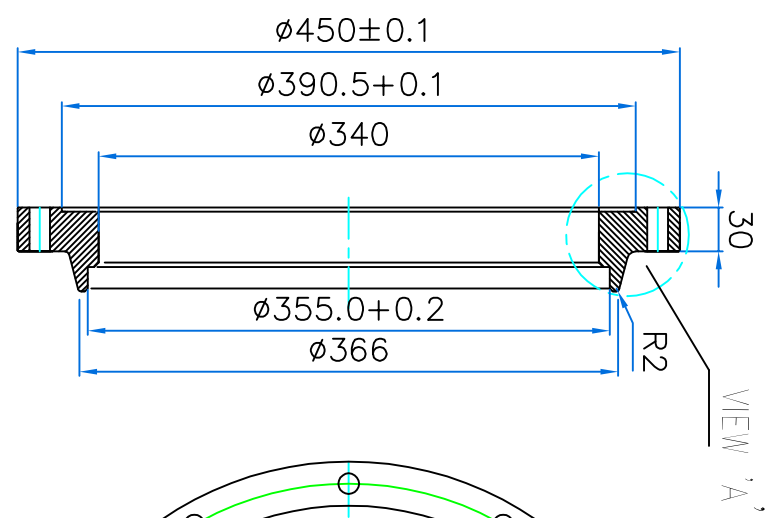

12 no., $\phi 14.0$ HOLES @ 420.0 PCD

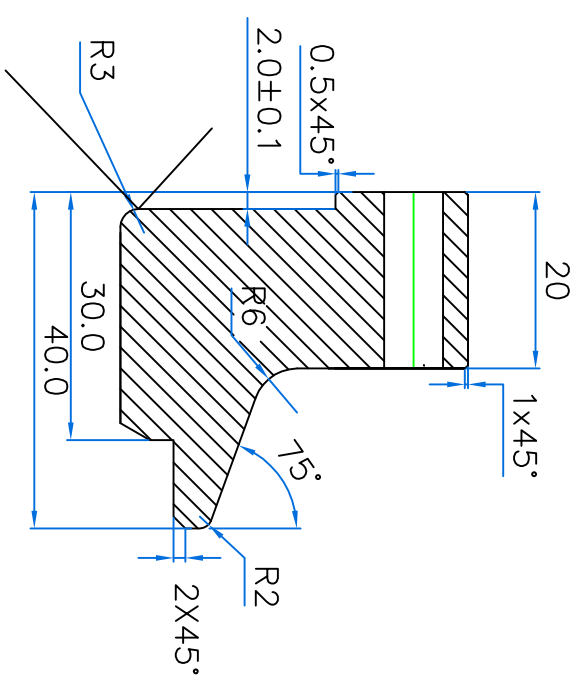

ENLARGED VIEW 'A'

- Note:
1. Sealing area shall be polished to RA 0.8 or better.
 2. All sharp edges shall be machined to 0.4x45°.
 3. PCD and flange centre shall be concentric within ± 0.05
 4. Finished flange shall be degreased and packed in 125 micron poly bag and sealed.
 5. Component shall be Machined to dimensions after welding to pipe

VAR. NO.	REMARKS	VAR. ITEM NO.	DESCRIPTION	DATE	DRWING NO.	IT. NO.	MATL. CODE	A	UNIT WGT.	NO. OF	ZONE
01							SS-304L		01		

TYPE OF PRODUCT: GSM-245
NAME OF CUSTOMER: BHARAT HEAVY ELECTRICALS LTD. HYDERABAD

DEPT. CODE	GRADE OF TOL. DIM. C/M/F	SCALE	WEIGHT(KG)

DRN. NAME	SIGN.	DATE	NO. OF
AL		15.02.15	VAR.
APPD. NAME	SIGN.	DATE	NO. OF
AMRAO		15.02.15	ITEM
REF. TO			NO. OF
RD DG 4 35 0520 6610			ITEMS

REV.	DATE	ALTERED CHECKED	REV.	DATE	ALTERED CHECKED	ZONE	TITLE	CARD CODE	SHEET NO.	NO. OF SHEETS
							FLANGE II	RD DG 4 35 0520 6613		

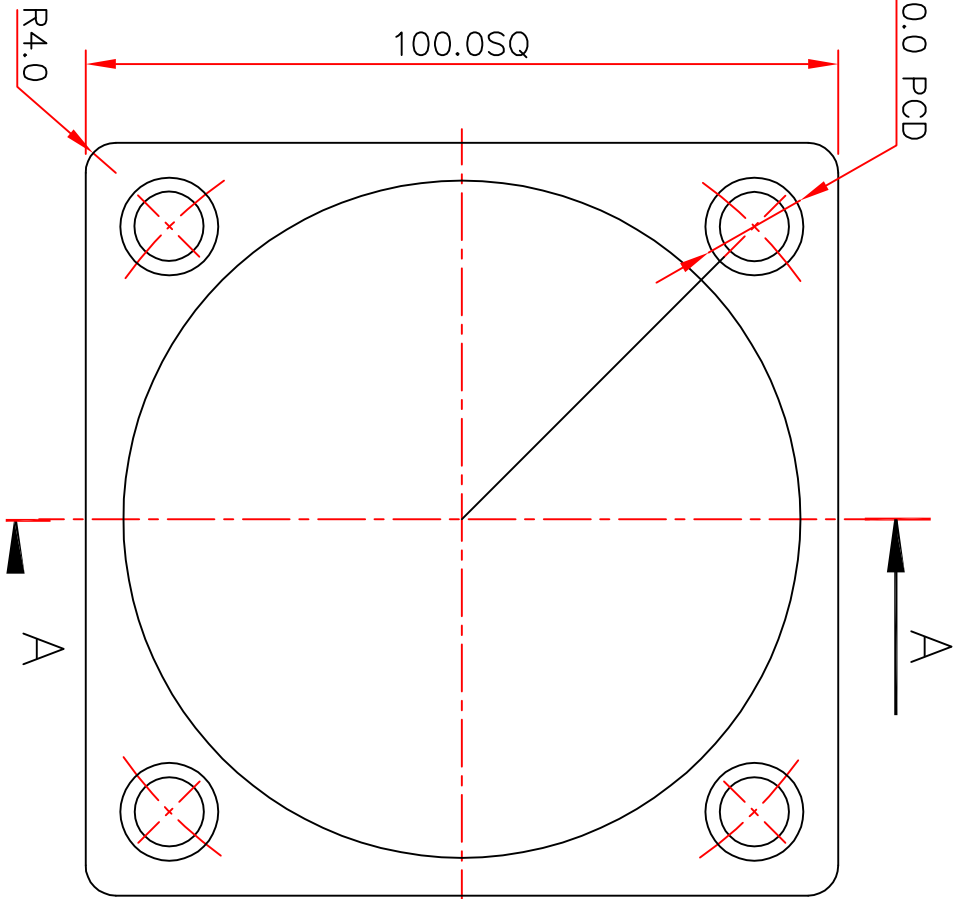
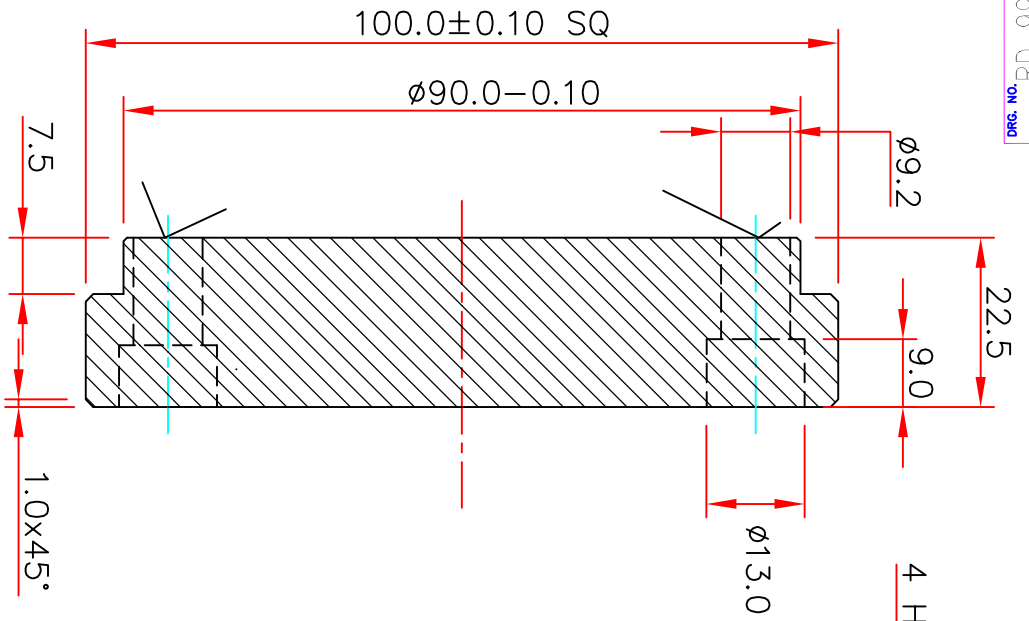

SECTION AA

MARKED SURFACE SHALL BE FINISHED TO RA 1.6

FINAL ON 15/11/08

VAR. NO.	REMARKS	VAR. NO.	ITEM NO.	DESCRIPTION	QTY	DRAWING NO.	ITNO.	MATL. CODE	A	UNIT WGT.	QTY.	ZONE
		01		SS PLATE	105.0 SQ x 25.0			SS 304				

TYPE OF PRODUCT
NAME OF CUSTOMER
GSM 145

DEPT. CODE	35	SCALE	N.TS	WEIGHT(KG)	
GRADE OF					
TOL. DIM.					
C/M/F					



BHARAT HEAVY ELECTRICALS LTD.
HYDERABAD

REV.	DATE	ALTERED	CHECKED	REV.	DATE	ALTERED	CHECKED	ZONE

DRN. NO.	AS REC.	DATE	NO. OF
APPD.	BY	02/02/08	VAR.
REF. TO			
RD 99 320 600			
ITEM NO.	2		
NO. OF	5		
ITEMS			

CARD CODE	RD 99 320 640	DRAWING NO.	RD 99 320 640
SHEET NO.		NO. OF SHEETS	

DUMMY FLANGE

THE INFORMATION ON THIS DOCUMENT IS THE PROPERTY OF BHARAT HEAVY ELECTRICALS LIMITED.
 IT MUST NOT BE USED DIRECTLY OR INDIRECTLY IN ANY WAY DETRIMENTAL TO THE INTEREST OF THE COMPANY.

INVENTORY NO. SIGN. AND DATE REF. DRG. NO.

O-RING GROOVE SURFACE SHALL BE FINISHED TO RA 0.8
 MARKED SURFACE SHALL BE FINISHED TO RA 1.6

ENLARGED VIEW 'A'

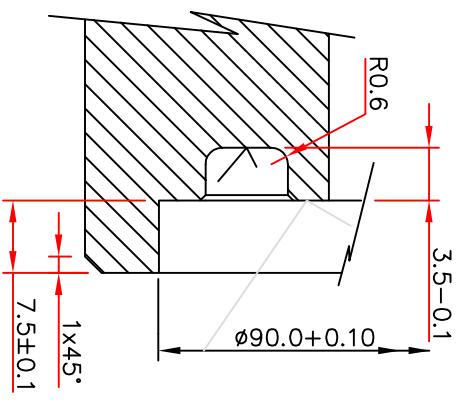

ENLARGED VIEW 'B'

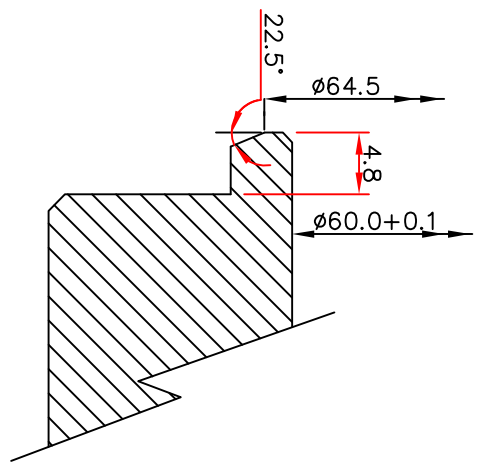

SECTION AA

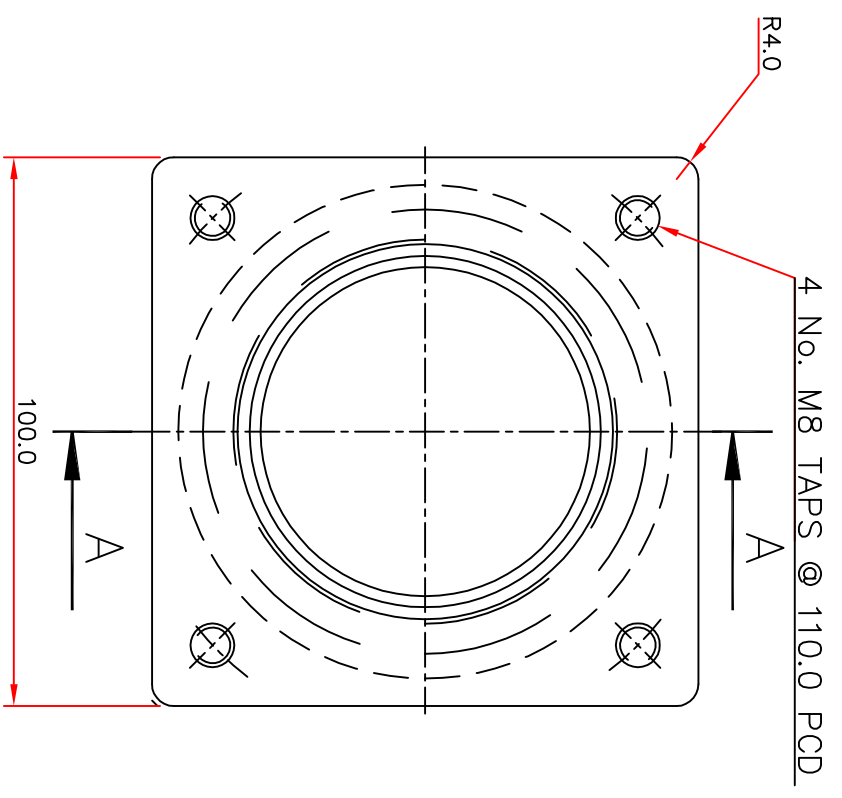
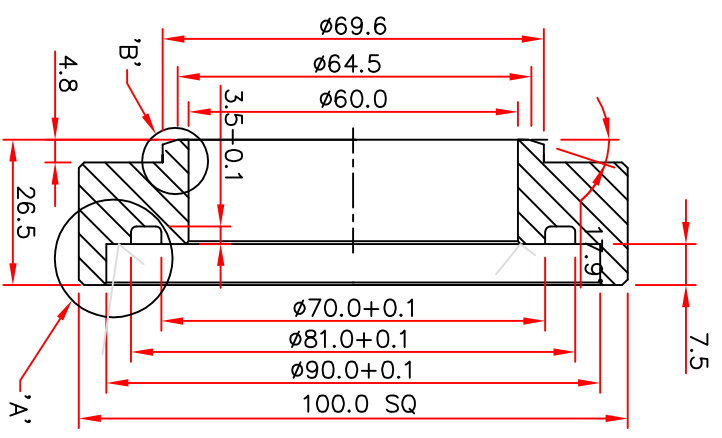

REV.	DATE	ALTERED	REV.	DATE	ALTERED
		CHECKED			CHECKED
		ZONE			ZONE

BHARAT HEAVY ELECTRICALS LTD.
 HYDERABAD

TYPE OF PRODUCT: **GSM 145**
 NAME OF CUSTOMER: **GSM 145**

DRN	NAME	DATE	NO. OF
APPD	BY	REV.	VAR.
REF. TO	REF. TO	ITEM	NO. OF
RD 99 320 600	RD 99 320 600	NO.	ITEMS
2	2		

VAR. NO.	ITEM NO.	DESCRIPTION	DRAWING NO.	ITNO.	MATL. CODE	UNIT WGT.	QTY.	ZONE
01	SS PLATE	105.0 SQ x 30.0		SS 304	A			

DEPT. CODE: 35
 GRADE OF TOL. DIM. C/M/P: NTS
 SCALE: NTS
 WEIGHT(G):
 TITLE: **FLANGE**
 CARD CODE: RD 99 320 610
 SHEET NO.:
 NO. OF SHEETS:

THE INFORMATION ON THIS DOCUMENT IS THE PROPERTY OF BHARAT HEAVY ELECTRICALS LIMITED.
IT MUST NOT BE USED DIRECTLY OR INDIRECTLY IN ANY WAY DETRIMENTAL TO THE INTEREST OF THE COMPANY.

INVENTORY NO.	SIGN. AND DATE	REF. DRG. NO.
---------------	----------------	---------------

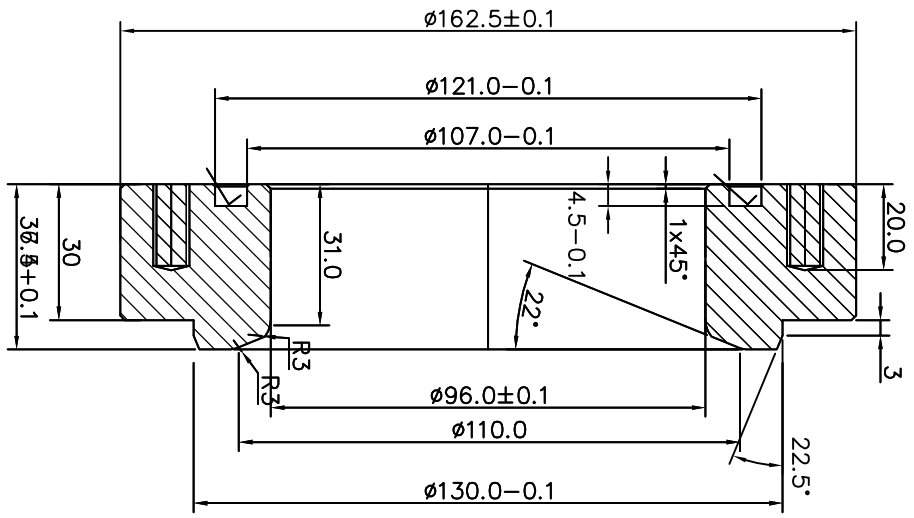

8 No. M8 TAPS @ 140.0 PCD, 20.0 deep

ALL SHARP EDGES SHALL BE MACHINED TO 0.4x45°
MARKED SURFACE SHALL BE FINISHED TO RA0.8

12/05/15

REV.	DATE	ALTERED	REV.	DATE	ALTERED
ZONE		CHECKED	ZONE		CHECKED

VAR. NO.	REMARKS	VAR. NO.	ITEM NO.	01	SS BLANK

TYPE OF PRODUCT	NAME OF CUSTOMER	SS-304L	01
CGSM-145			

DEPT. CODE	GRADE OF TUB. DIM. C/M/F	SCALE	WEIGHT(KG)
		NTS	

DRAWING NO.	VAR.	IT. NO.	MATL. CODE	A	L	N	UNIT WGT.

DRN. NAME	SIGN.	DATE	NO. OF
KSRAO		26/12/06	VAR.
AL		02/01/08	01
APPD. MM/RAO		09/01/08	

REF. TO	NO. OF
RD DG 4 35 1133 4100	1

CARD CODE	DRAWING NO.	NO. OF SHEETS
RD DG 4 35 1133 4160		

THE INFORMATION ON THIS DOCUMENT IS THE PROPERTY OF BHARAT HEAVY ELECTRICALS LIMITED.
IT MUST NOT BE USED DIRECTLY OR INDIRECTLY IN ANY WAY DETRIMENTAL TO THE INTEREST OF THE COMPANY.

INVENTORY NO.	SIGN. AND DATE	REF. DRG. NO.
---------------	----------------	---------------

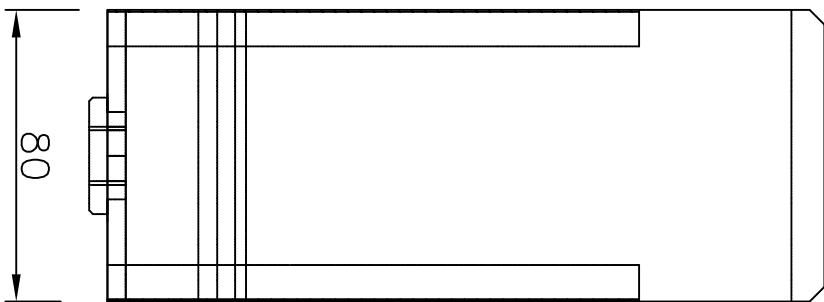
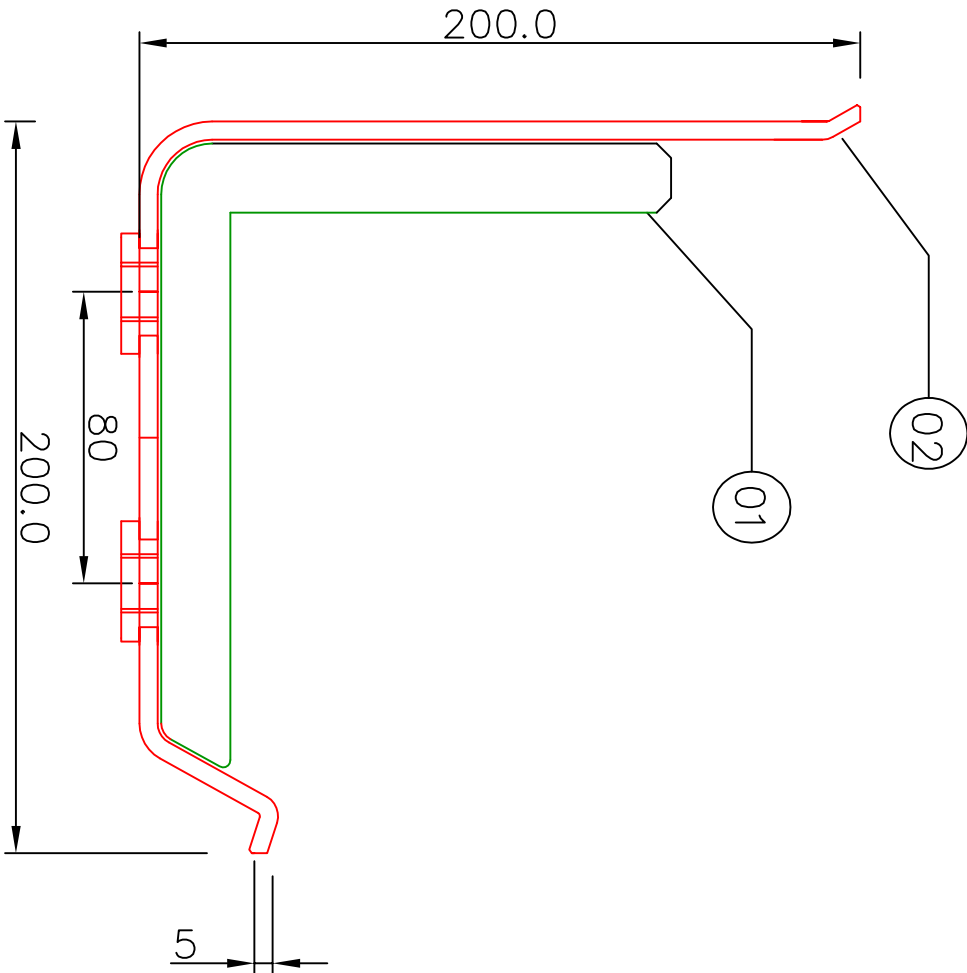

1. ALL SHARP EDGES SHALL BE MACHINED TO 0.4x45°
2. PIPE AND FLANGE TO BE TIG / MIG WELDING WITH SUITABLE SS ELECTRODE
3. THE ROOT SHOULD BE HOMOGENEOUS AND CONTINUOUS.

VAR/00	REMARKS	VAR NO.	ITEM NO.	DESCRIPTION	STD	DRAWING NO.	T.NO.	MATL. CODE	A	UNIT	UNIT WGT.	QTY.	ZONE
			02	SUPPORT BRACKET		RD DG 4 35 1133 4130B		SS-304L				01	
			01	SUPPORT PLATE		RD DG 4 35 1133 4130A		SS-304L				02	

TYPE OF PRODUCT
NAME OF CUSTOMER
CGSM-145

DEPT.	GRADE OF TOL DIM	SCALE	NTS	WEIGHT(KG)

DRN	NAME	SIGN.	DATE	NO OF
04	KSRNAO		04.01.12	VAR.
APPD	MNRAO		04.01.12	01

TITLE	CARD CODE	DRAWING NO.	SHEET NO.	NO. OF SHEETS
SUPPORT BRACKET ASSY.		RD DG 4 35 1133 4130		

REV.	DATE	ALTERED	ZONE
		CHECKED	

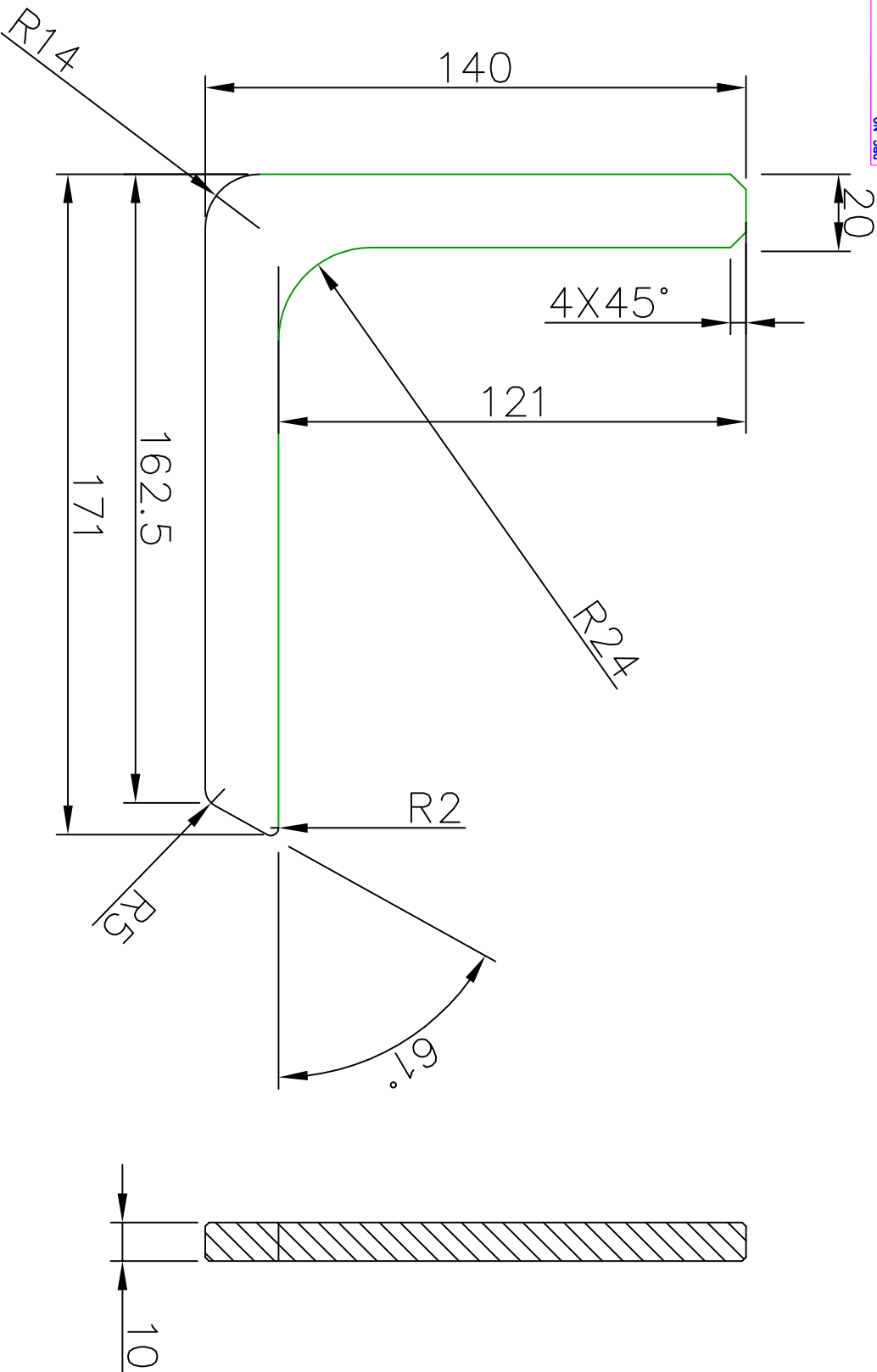

ALL SHARP EDGES SHALL BE MACHINED TO 0.4x45°.

VAR.00	REMARKS	VAR. NO.	ITEM NO.	01	SS PLATE	DESCRIPTION	STD	DRAWING NO.	ITEM NO.	MATL. CODE	A	UNIT	UNIT WGT.	QTY.	GS	ZONE
										SS-304L			08			

TYPE OF PRODUCT		NAME OF CUSTOMER		CGIS-145				
DEPT.	GRADE OF TOL. DIM. C/M/F	SCALE	WEIGHT(KG)	DRN. NO.	NAME	SIGN.	DATE	NO. OF
		NTS		04	KSRAO		04.01.12	VAR.
				01	AL		04.01.12	NO.
					MMRRAO		04.01.12	ITEM
								NO. OF
								ITEMS

REV.	DATE	ALTERED	REV.	DATE	ALTERED	CARD	TITLE	DRAWING NO.	NO. OF SHEETS
ZONE		CHECKED	ZONE		CHECKED	RD DG 4 35 1133 4130A	SUPPORT PLATE	RD DG 4 35 1133 4130A	1

THE INFORMATION ON THIS DOCUMENT IS THE PROPERTY OF BHARAT HEAVY ELECTRICALS LIMITED. IT MUST NOT BE USED DIRECTLY OR INDIRECTLY IN ANY WAY DETRIMENTAL TO THE INTEREST OF THE COMPANY.

INVENTORY NO.	SIGN. AND DATE	REF. DRG. NO.
---------------	----------------	---------------

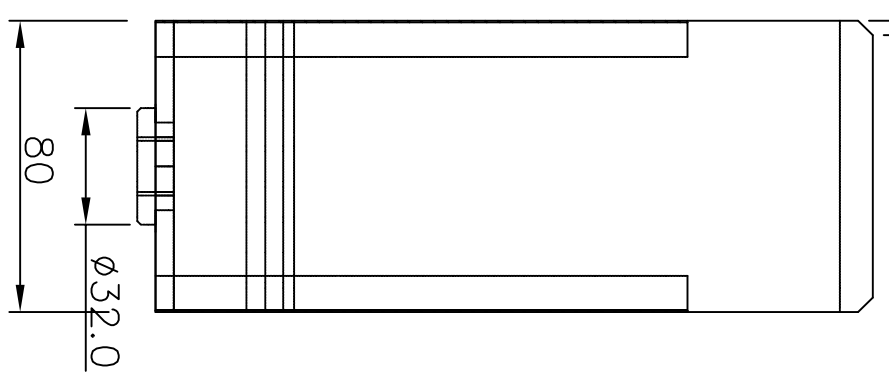
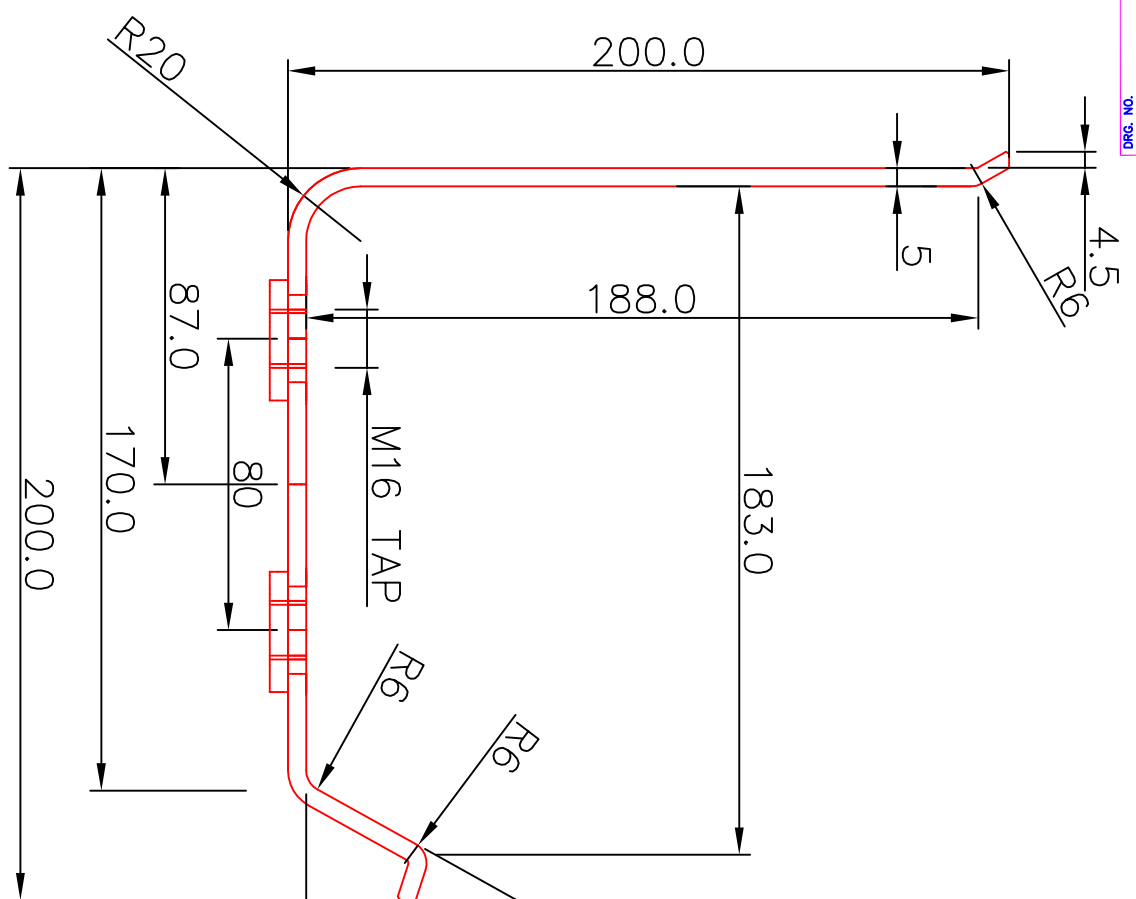

ALL SHARP EDGES SHALL BE MACHINED TO 0.4x45°

REV.	DATE	ALTERED	ZONE
		CHECKED	

REV.	DATE	ALTERED	ZONE
		CHECKED	

TYPE OF PRODUCT		CGSM-145	
NAME OF CUSTOMER			
DEPT.			
SCALE		NTS	
DWN			
CHKD			
APPR			
REF. TO			
DRA			
SHE			

VAR.00	REMARKS	VAR. NO.	ITEM NO.	01	SS SHEET	SS-304L	04	UNIT	QTY.	GS	ZONE

TITLE	SUPPORT BRACKET
DRAWING NO.	RD DG 4 35 1133 4130B
SHEET NO.	
NO. OF SHEETS	

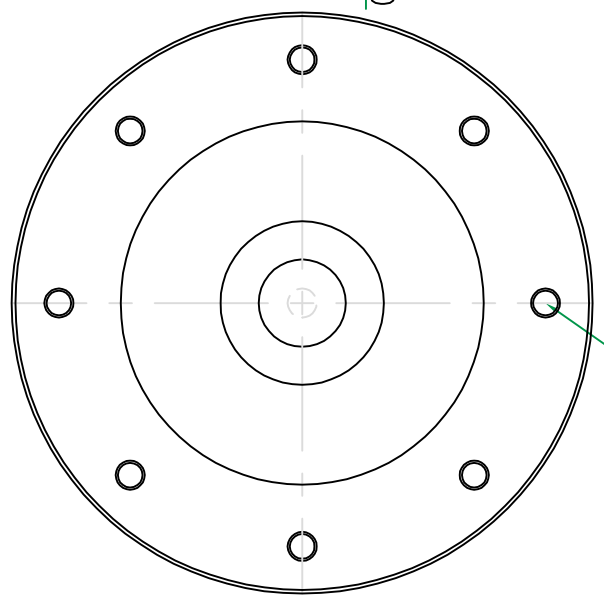
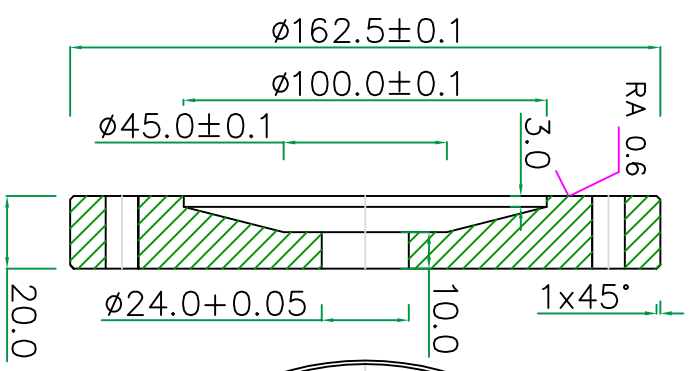

8 NO., 9.2 CLEAR HOLES
@135±0.07 PCD WITH 0.4X45° C/F

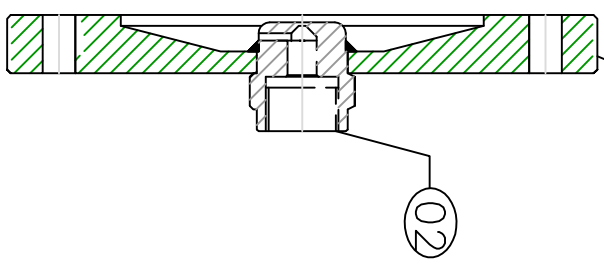

ASSEMBLY

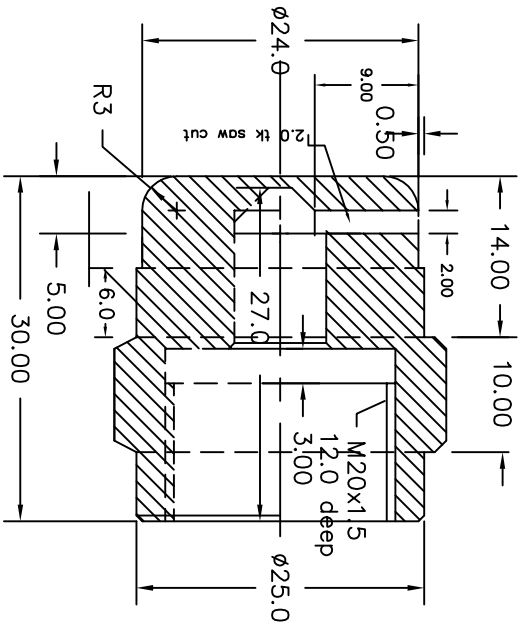

SECTION AA

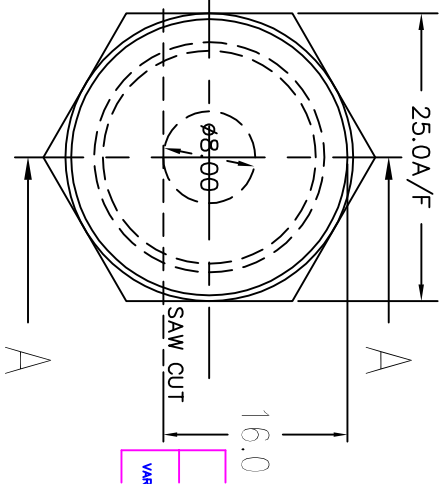

GAS STUD (2)

VAR. NO.	REMARKS

VAR. NO.	ITEM NO.	DESCRIPTION	DRAWING NO.	ITNO.	MATL. CODE	MATL. SPECN.	UNIT WT.	QTY.	ZONE
02	01	GAS STUD	-		SS-304L		0.16 KG	01	
		FLANGE - III	RD RD 4 35 0617 0983		SS-304L		2.3 KG	01	

TYPE OF PRODUCT
NAME OF CUSTOMER
GSM-420

DEPT. CODE	GRADE OF C/M/F	SCALE	WEIGHT(KG)
		NTS	2.5



BHARAT HEAVY ELECTRICALS LTD.
HYDERABAD

DRN. NO.	NAME	SIGN.	DATE
CMD	KSRRAO		26/12/05
APPD	HISJAIN		02/01/06

REV.	DATE	ALTERED CHECKED	ZONE	REV.	DATE	ALTERED CHECKED	ZONE

TITLE	FLANGE-V
CARD CODE	
DRAWING NO.	RD DG 4 35 0617 0983
SHEET NO.	
NO. OF SHEETS	

4 No., $\phi 9.2$ Clear Holes With Counters @ 110.0 PCD

(~1.6)

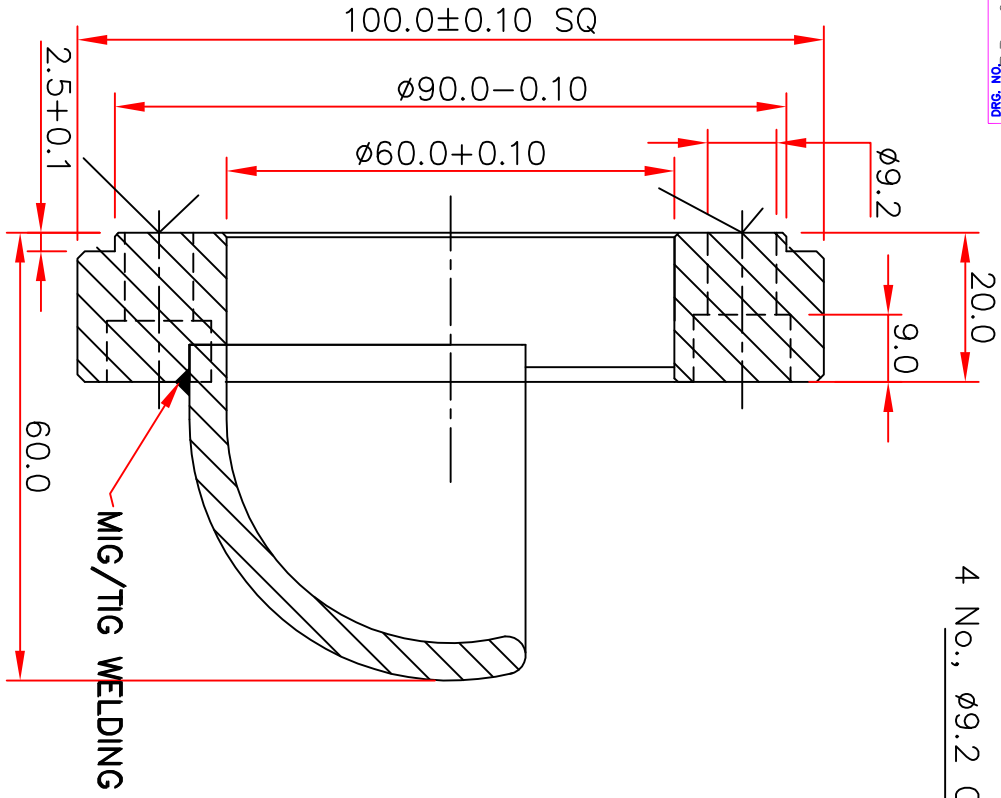

SECTION AA

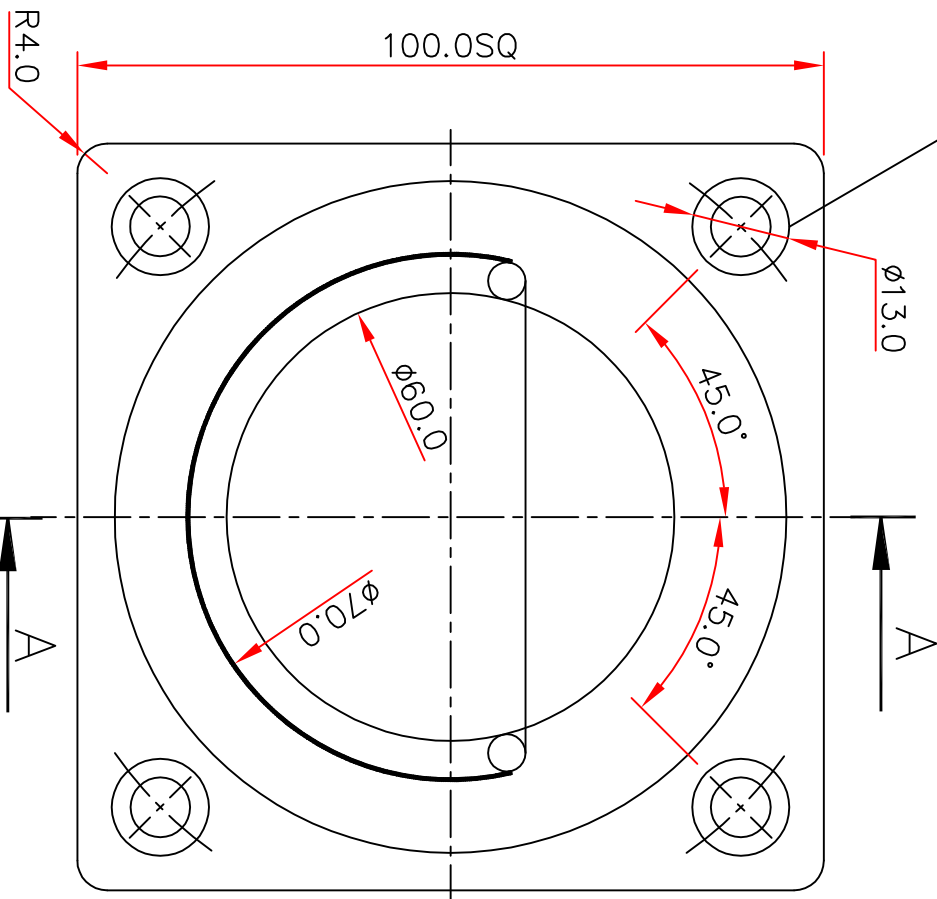
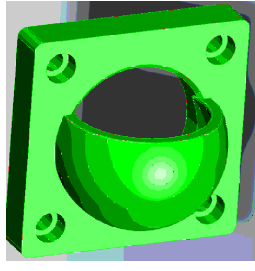

WELDING SHALL BE HOMOGENEOUS AND CONTINUOUS.
 MARKED SURFACE SHALL BE FINISHED TO RA 1.6

VAR. NO.	ITEM NO.	DESCRIPTION	DRAWING NO.	ITNO.	MATL. CODE	MATL. SPECN.	UNIT WGT.	QTY.	ZONE
	02	PROTECTIVE COVER	RD 99 320 632		SS 304-L		0-		
	01	FLANGE	RD 99 320 631		SS 304-L		01		

TYPE OF PRODUCT
 NAME OF CUSTOMER
GSM 145

DEPT. / SEC. / TOL. DIM. / C/M/P	SCALE	WEIGHT(KG)	DRN. AS REC.	NAME	SIGN.	DATE	NO. OF VAR.
	1:1						

REV.	DATE	ALTERED CHECKED	REV.	DATE	ALTERED CHECKED

TITLE	CARD CODE	DRAWING NO.	SHEET NO.	NO. OF SHEETS
RUPTURE DISK COVER	RD 99 320 630	RD 99 320 630	2	5

THE INFORMATION ON THIS DOCUMENT IS THE PROPERTY OF BHARAT HEAVY ELECTRICALS LIMITED. IT MUST NOT BE USED DIRECTLY OR INDIRECTLY IN ANY WAY DETRIMENTAL TO THE INTEREST OF THE COMPANY.

INVENTORY NO. SIGN. AND DATE REF. DRG. NO.

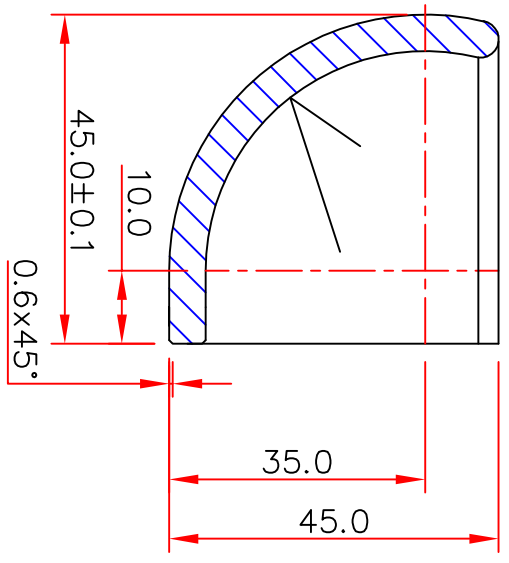

SECTION AA

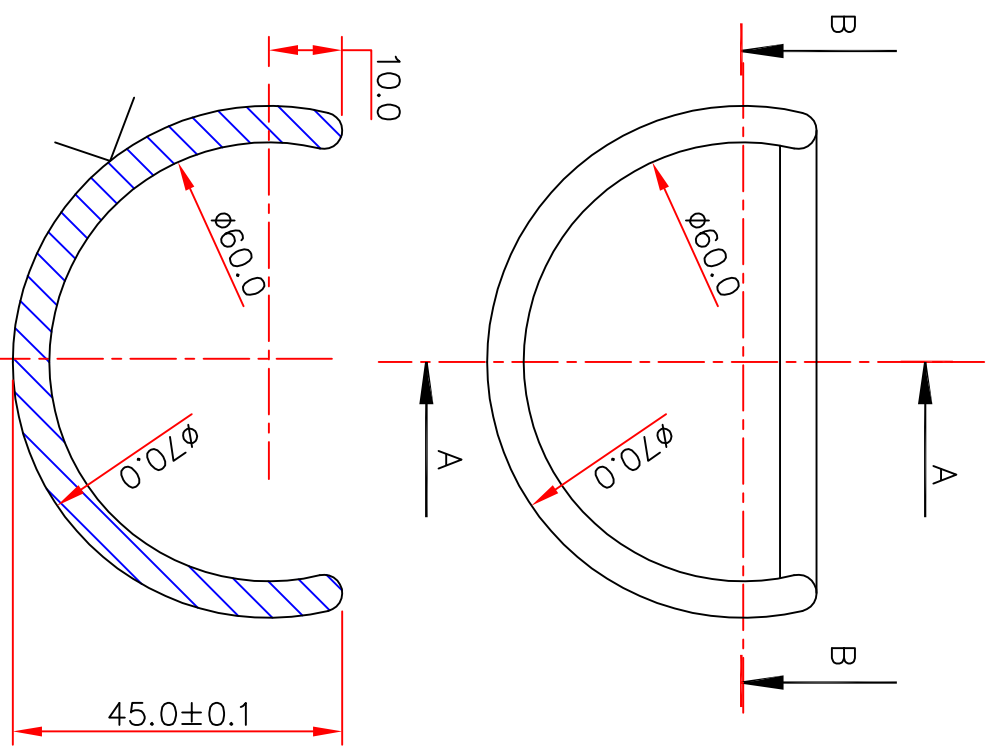

SECTION BB

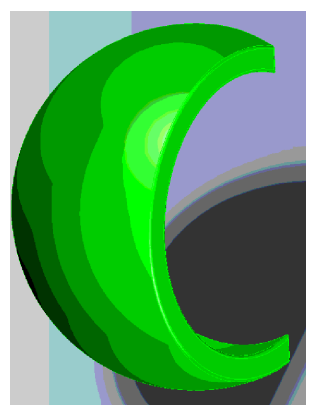
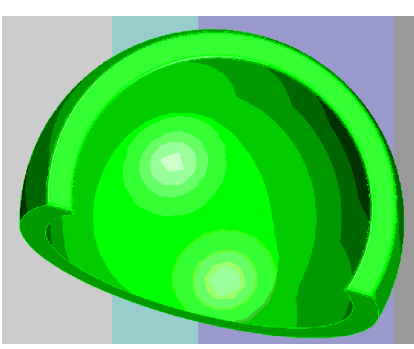

SURFACE SHALL BE FINISHED TO RA1.6
 COMPONENT SHALL BE MADE USING SUITABLE PATTERN.
 ALL SHARP EDGES SHALL BE MACHINED TO 0.4x45°

REV.	DATE	ALTERED	REV.	DATE	ALTERED	ZONE
		CHECKED			CHECKED	

DEPT. CODE	ISS. TOL. DIM. C/M/E	SCALE	WEIGHT(KG)
33		1:1	

CHD	DRN	NAME	SIGN.	DATE	NO. OF
					ITEMS

REV.	NO. OF
RD 99 320 632	2

CHD	DRN	NAME	SIGN.	DATE	NO. OF
					ITEMS

REV.	NO. OF
RD 99 320 632	0

VAR.00	REMARKS	VAR. ITEM NO.	01	SS PLATE
--------	---------	---------------	----	----------

TYPE OF PRODUCT: GSM 145
 NAME OF CUSTOMER: BHARAT HEAVY ELECTRICALS LTD. HYDERABAD

TITLE: PROTECTIVE COVER

THE INFORMATION ON THIS DOCUMENT IS THE PROPERTY OF BHARAT HEAVY ELECTRICALS LIMITED.
IT MUST NOT BE USED DIRECTLY OR INDIRECTLY IN ANY WAY DETRIMENTAL TO THE INTEREST OF THE COMPANY.

INVENTORY NO.	SIGN. AND DATE	REF. DRG. NO.
---------------	----------------	---------------

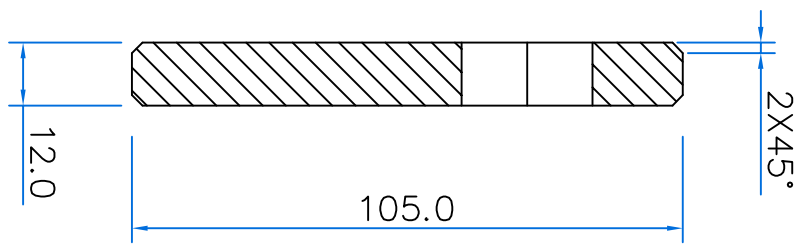
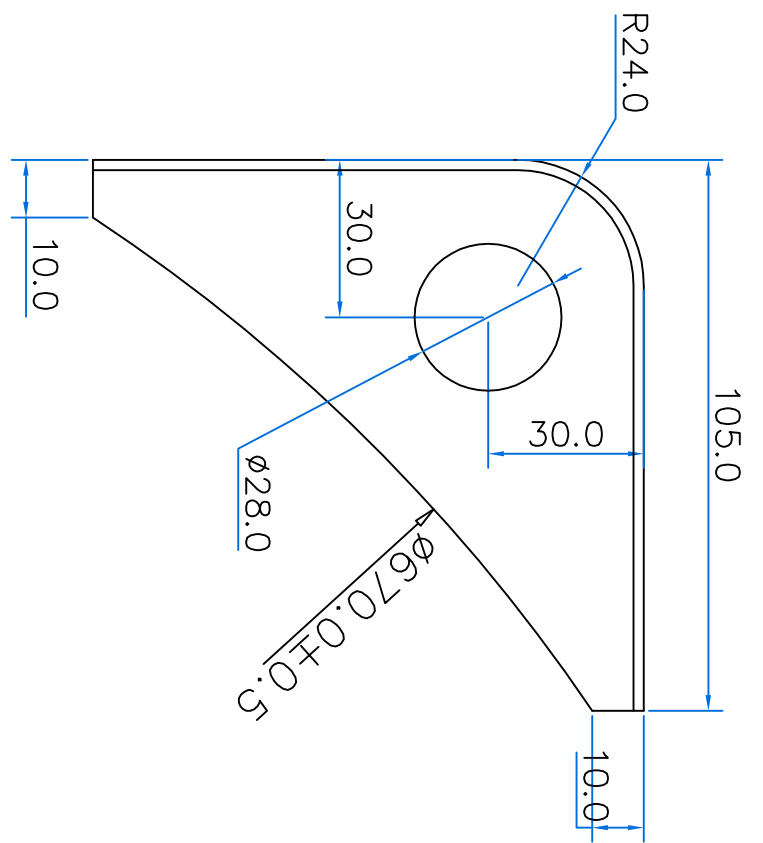

ALL SHARP EDGES SHALL BE MACHINED TO 0.4x45°.

VAR. NO.	REMARKS	VAR. NO.	ITEM NO.	SS PLATE	SS-304L	04
				DESCRIPTION		
				DRAWING NO.		
				VAR.		
				MATL. SPECN.		
				A		
				C		
				L		
				N		
				S		
				ZONE		

TYPE OF PRODUCT
NAME OF CUSTOMER
CGIS-145

DEPT.	GRADE OF TOL. DIM. C/M/F	SCALE	WEIGHT(KG)	DRAWING NO.	REF. TO	NO. OF SHEETS
		NTS		RD DG 4 35 1133 4100		

REV.	DATE	ALTERED	REV.	DATE	ALTERED
		CHECKED			CHECKED
ZONE			ZONE		

TYPE OF PRODUCT	NAME OF CUSTOMER	SS-304L	04
DRAWING NO.	REF. TO	NO. OF SHEETS	
RD DG 4 35 1133 4140			

REV.	DATE	ALTERED	REV.	DATE	ALTERED
		CHECKED			CHECKED
ZONE			ZONE		

INVENTORY NO.	SIGN. AND DATE	REF. DRG. NO.
---------------	----------------	---------------

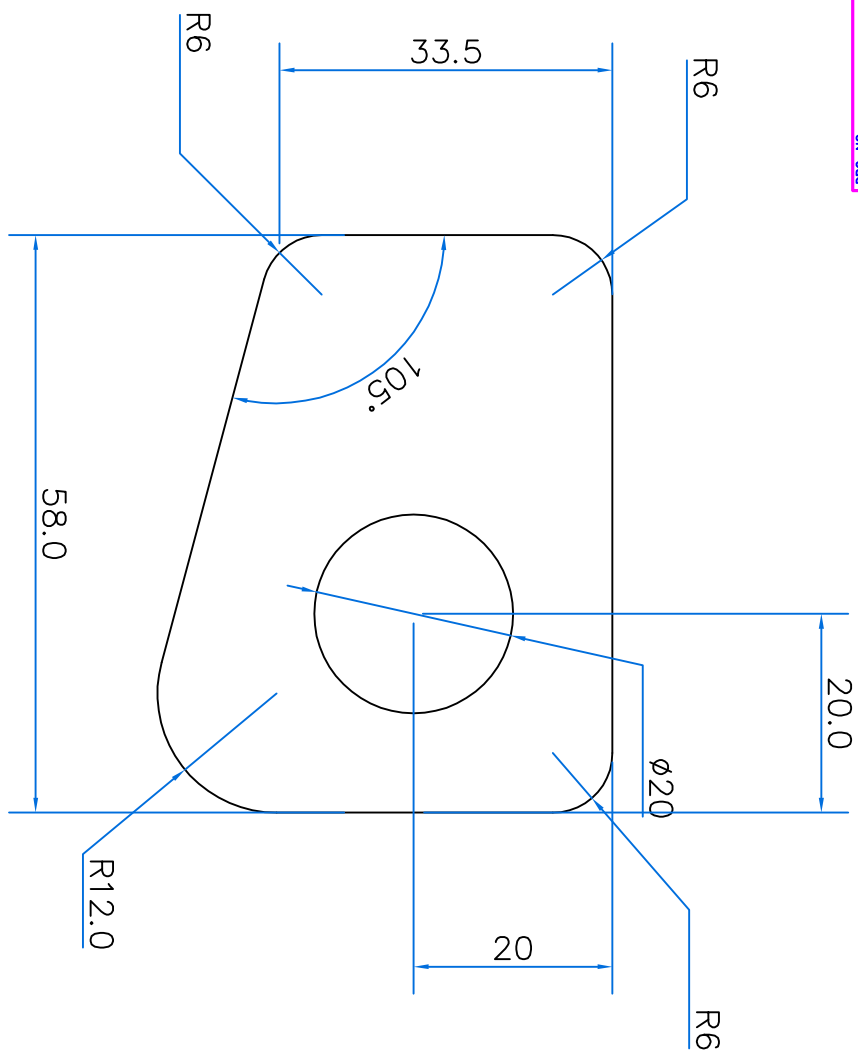

VAR. NO.	REMARKS	VAR. NO.	ITEM NO.	DESCRIPTION	UNIT	DRIVING NO.	ITAND.	MATL. CODE	A	UNIT	UNIT WT.	QTY.	ZONE
		01		SS BLANK				SS-304L			04		

TYPE OF PRODUCT: GSM 245
 NAME OF CUSTOMER: BHARAT HEAVY ELECTRICALS LTD. HYDERABAD

DEPT. CODE	GRADE OF TOL. DIM. C/M/F	SCALE	WEIGHT(KG)	DEN. AL	NAME	SIGN.	DATE	NO. OF
				AL	HYDERABAD		15.02.15	15.02.15

REV.	DATE	ALTERED	REV.	DATE	ALTERED	ZONE	ZONE
		CHECKED			CHECKED		

DEPT. CODE: RD DG 4 35 0520 6610
 TITLE: LIFTING LUG I
 CARD CODE: RD DG 4 35 0520 6614
 SHEET NO.:
 NO. OF SHEETS:

THE INFORMATION ON THIS DOCUMENT IS THE PROPERTY OF BHARAT HEAVY ELECTRICALS LIMITED.
IT MUST NOT BE USED DIRECTLY OR INDIRECTLY IN ANY WAY DETRIMENTAL TO THE INTEREST OF THE COMPANY.

INVENTORY NO.	SIGN. AND DATE	REF. DRG. NO.
---------------	----------------	---------------

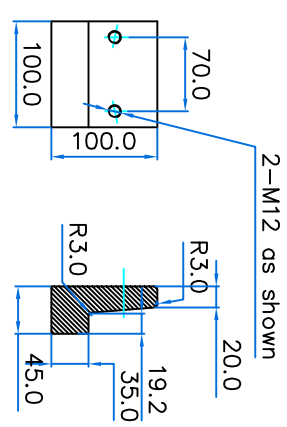
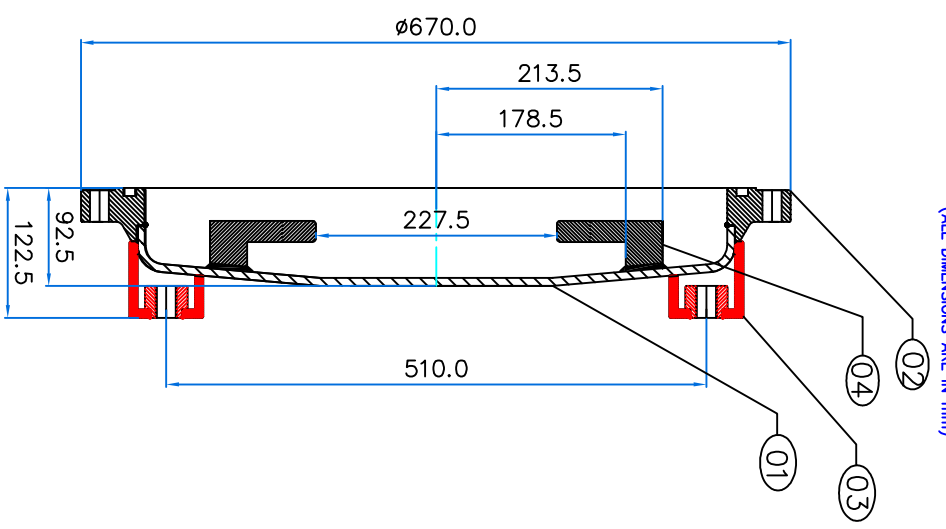
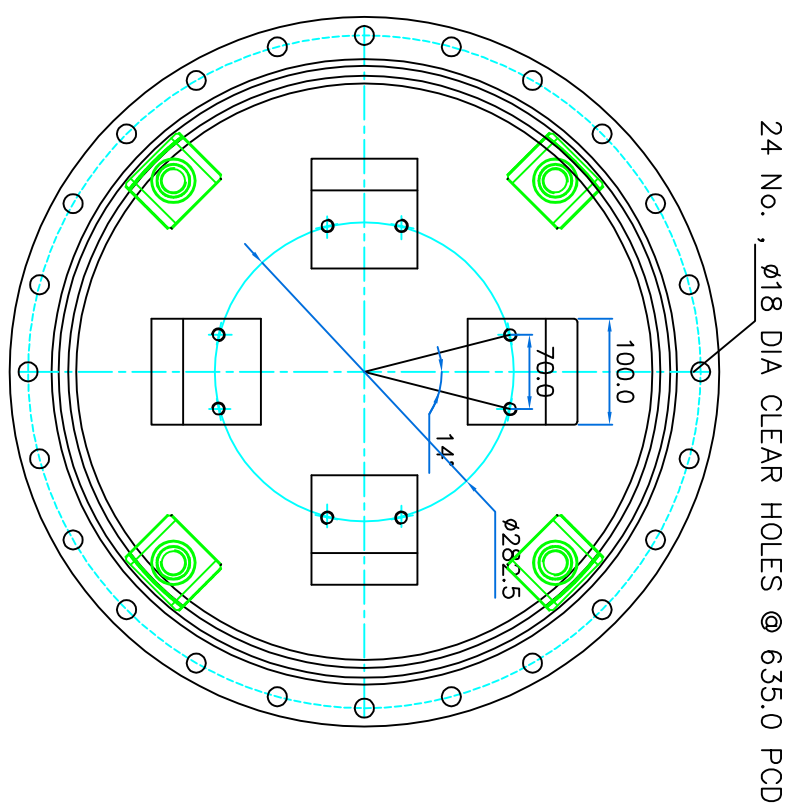

02 SUPPORT
QTY : 4 Nos

Note:

1. FLANGE TO BE TIG / MIG WELDING WITH SUITABLE SS ELECTRODE
2. THE ROOT SHOULD BE HOMOGENEOUS AND CONTINUOUS.
3. TESTED ASSEMBLIES TO BE DEGREASED, SAND BLASTED AND POWDER COATED ON OUTSIDE.
4. ELECTRO POLISH INSIDE SURFACE.
5. ALL WELDINGS SHALL BE GROUNDED TO DIMENSIONS.
6. FLANGES SHALL BE MACHINED TO DRAWING AFTER WELDING TO DISH.

VAR. NO.	REMARKS	VAR. NO.	ITEM NO.	DESCRIPTION	IS	DRAWING NO.	ITNO.	MATL. CODE	MATL. SPECN.	A	UNIT	QTY.	ZONE
			04	SUPPORT				SS-304L				04	
			03	BRACKET		RD 99 320 700		SS-304L				04	
			02	FLANGE		RD DG 4 35 0520 6622		SS-304L				01	
			01	DISH		RD DG 4 35 0520 6621		SS-304L				01	

TYPE OF PRODUCT
NAME OF CUSTOMER
GSM-245

DEPT.	GRADE OF TOL. DIM. C/M/F	SCALE	WEIGHT(KG)
BHARAT HEAVY ELECTRICALS LTD. HYDERABAD			

REV. DATE	ALTERED CHECKED	REV. DATE	ALTERED CHECKED
ZONE	ZONE	ZONE	ZONE

DRN	NAME	SIGN.	DATE	NO. OF
AL	AL		07/02/15	VAR.
APPD	NAME		07/02/15	
AL	AMRAO			
REF. TO	REP. TO			
RD DG 4 35 0520 6600	RD DG 4 35 0520 6600			
CARD CODE	DRAWING NO.			
RD DG 4 35 0520 6620				
SHEET NO.	NO. OF SHEETS			

DISH ASSY

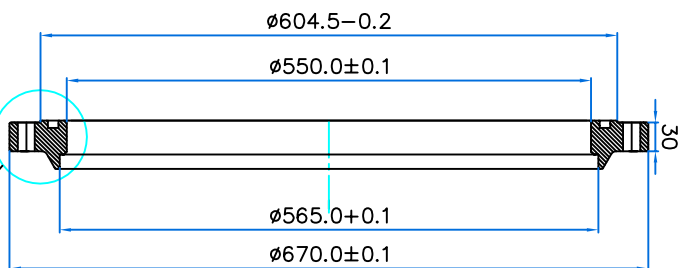
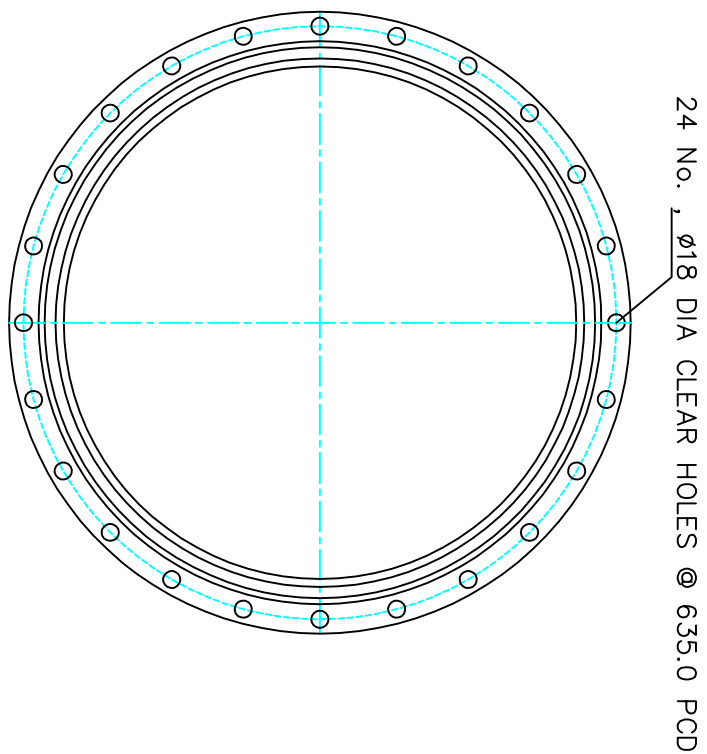

REFER DETAIL 'A'

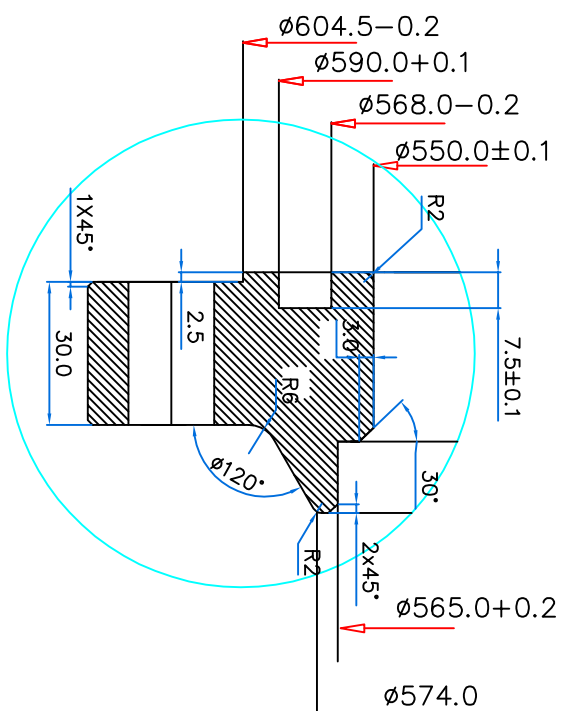

DETAIL 'A'

- Note:
1. Sealing area shall be polished to RA 0.8 or better.
 2. M 16.0 Taps shall be chamfered uniformly (0.8x45°).
 3. PCD and flange centre shall be concentric within ± 0.05
 4. Finished flange shall be degreased and packed in 125 micron poly bag and sealed.
 5. Component shall be Machined to dimensions after welding to dish

VAR. NO.	REMARKS	VAR. NO.	ITEM NO.	DESCRIPTION	DR. NO.	IT. NO.	MATL. CODE	A	UNIT	QTY.	ZONE
		01		FLANGE			SS-304L			01	

TYPE OF PRODUCT
 NAME OF CUSTOMER
GSM-245



DRN	AL	SIGN.	DATE	NO. OF
CHKD	AL		07/02/15	VAR.
APPD	MMRAO		07/02/15	ITEM
REF. TO	RD DG 4 35 0520			NO. OF
REV.				ITEMS

REV.	DATE	ALTERED	REV.	DATE	ALTERED	DEPT.	GRADE OF	SCALE	WEIGHT(KG)	CARD	DRAWING NO.	SHEET NO.	NO. OF SHEETS
		CHECKED			CHECKED		TOL. DIM. C/M/F			RD DG 4 35 0520	6600	RD DG 4 35 0520	6622

FLANGE

