

THE INFORMATION ON THIS DOCUMENT IS THE PROPERTY OF BHARAT HEAVY ELECTRICALS LIMITED. IT MUST NOT BE USED DIRECTLY OR INDIRECTLY IN ANY WAY DETRIMENTAL TO THE INTEREST OF THE COMPANY

COMPUTER FILE NAME
36103025.DWG

REF. DRG. NO.

SIGN. AND DATE

INVENTORY NO

DRG. NO. 3-61-104-03239

SH T. 0 1 OF 0 1

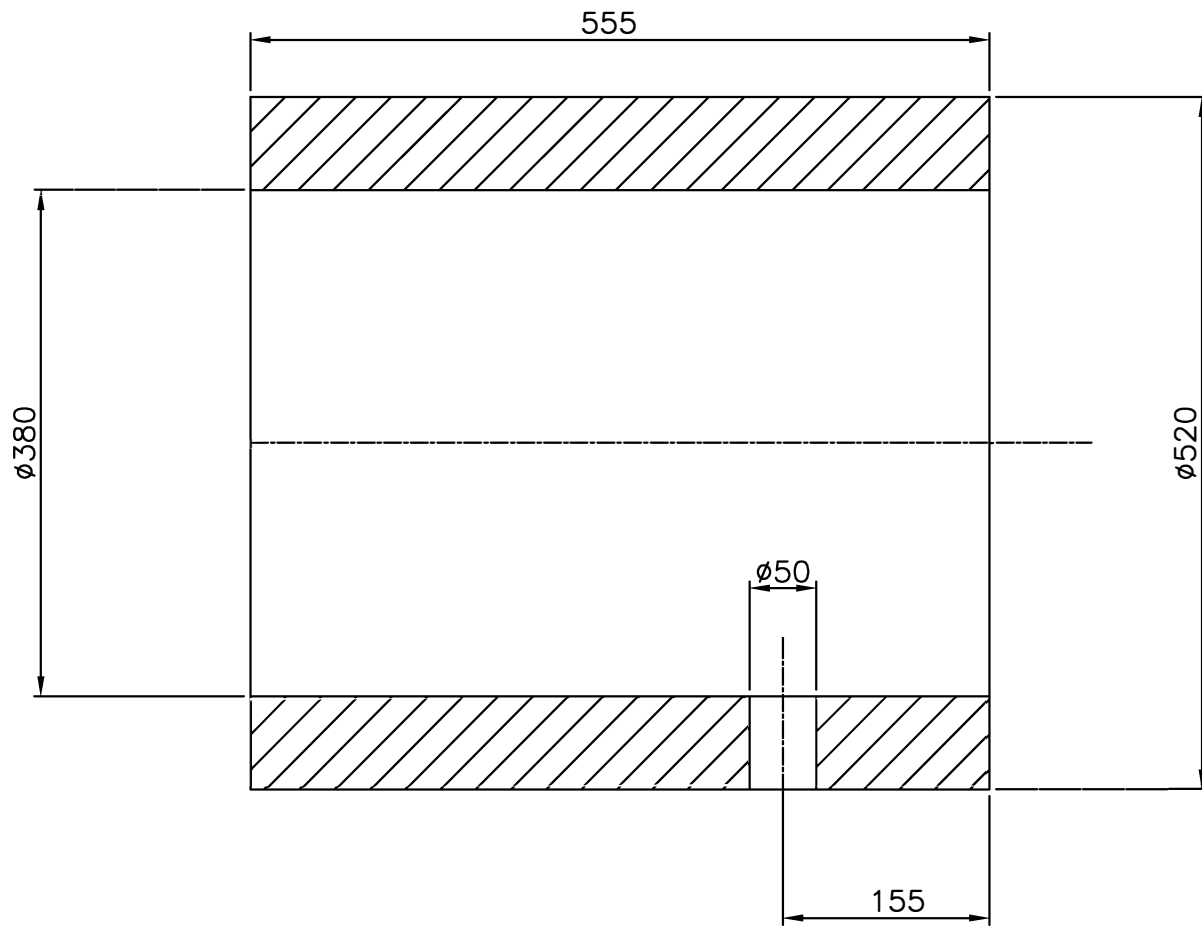

6.3/

NOTE

1. FORGING TO BE ROUGH MACHINED TO DIMENSIONS INDICATED IN THE DRAWING
2. CHAMFER, CORNERS TO BE R2 FILLET RADIUS TO BE R3.
3. TEST ULTRASONICALLY AS PER SPECIFICATION AA0850118 CAT-3
4. TOLERANCE ON DIAMETERS AND LENGTHS ±1MM

01	FORGING			BA9413150010	430	431
				AA19331		1
ITEM NO	DESCRIPTION	DRAWING NO.	VAR. NO.	MATERIAL CODE	NET WT.	GROSS WT.
				MATERIAL SPECN.	QUANTITY	

THE FOLLOWING CONDITIONS APPLY EXCEPT OTHERWISE STATED...

1. REF. TO HY0230261 FOR UNSPECIFIED TOLERANCES.
2. CHAMFER M/CD SHARP EDGES 1.2 TO 1.0 AT 45°.
3. INTERNAL M/CD CORNER RADII 1 TO 0.7.
4. THE SURFACE ROUGHNESS WHEREVER NOT SHOWN SHALL BE TAKEN FROM THE SURFACE ROUGHNESS SHOWN OUT SIDE BACK SLASHES GIVEN AT THE TOP MOST RIGHT CORNER OF THE DRG.

TYPE OF PRODUCT OR NAME OF CUSTOMER/PROJECT		XRP 1043 BOWL MILL				
BHARAT HEAVY ELECTRICALS LTD. HYDERABAD		NAME	SIGN.	DATE	NO. OF VAR.	
		DRN.				
		CHD.	NDS/AS	11.3.09	-NA-	
		APPD.	S.GHATGE	11.3.09		
DEPT. PULV. ENGG CODE 446	UNTOL. DIMS. GR. ϕ /M/F	SCALE 1:5	WEIGHT (KG) 430	REF. TO ASSY. DRG. 0-61-104-00759	ITEM NO.	NO. OF ITEMS -NA-
TITLE RING II (R/M FORGING-KMP 350)			DRAWING NO. 3-61-104-03239		REV. 00	
			SHT. No 01	NO. OF SHT. 01		

REV.	DATE	ALTERED	REV.	DATE	ALTERED
		CHD/APPD			CHD/APPD
ZONE			ZONE		