

FIRST ANGLE PROJECTION

(ALL DIMENSIONS ARE IN mm)

DRG.NO. 3-61-388-02135

THE INFORMATION ON THIS DOCUMENT IS THE PROPERTY OF BHARAT HEAVY ELECTRICALS LTD. IT MUST NOT BE USED DIRECTLY OR INDIRECTLY IN ANY WAY DETRIMENTAL TO THE INTEREST OF THE COMPANY.

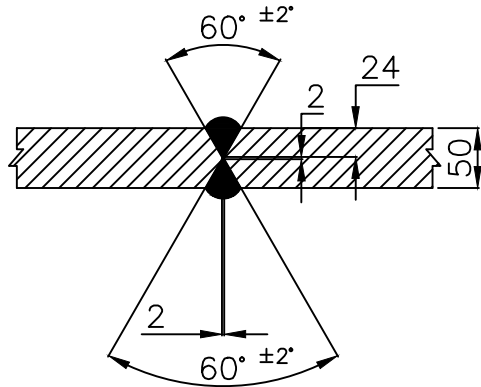

WELDING DETAIL

NOTES:-

1. FLAT END TO BE MAINTAINED TO 330mm
2. WELDING TO BE AS PER WPS:WE001
3. ALL BUTT WELDS TO BE FULL PENETRATION 'X' WELDS.
4. CARRY OUT LPI AFTER BACK CHIPPING.
5. ALL BUTT WELDS TO BE 10% SPOT RT TESTED AS PER HY0850170
6. MINIMUM THICKNESS AT RADIUS SHALL NOT BE LESS THAN 46 mm.

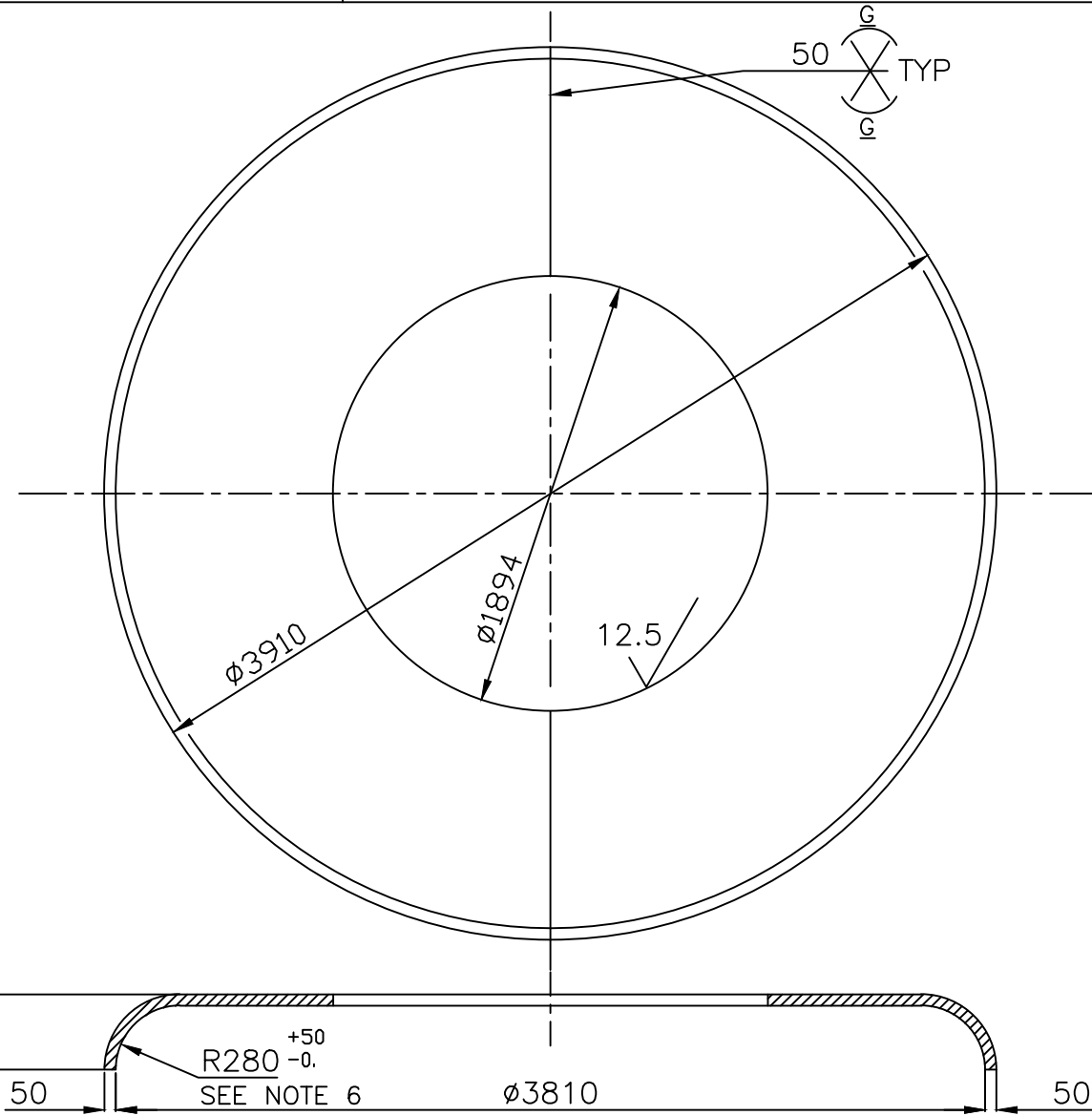

01	PLATE	4-61-388-03083				5117.00	7240
ITEM NO	DESCRIPTION	DRAWING NO.	VAR. NO.	RAW MATERIAL SIZE OR CASTING DRG.NO. OR FORGING DRG.NO.	MATERIAL CODE	NET WT.	GROSS WT.
					MATERIAL SPECN.	QUANTITY	

36102135 FILE NAME

REF.DRG.NO.

REV.	DATE	ALTERED	REV.	DATE	ALTERED
06	19.11.09	CHD.AMAN APPD. SG	05	31.1.06	CHD.AMAN APPD. SG
ZONE DRG 46138803083 ADDED			ZONE DIM Ø1894 WAS Ø1905.		

INVENTORY NO.

REV.	DATE	ALTERED	REV.	DATE	ALTERED
04	29.11.05	CHD.AMAN APPD. SG	03	26.5.05	CHD. APPD.
ZONE NOTE NO.6 ADDED.			ZONE PETALS REMOVED. NOTES 3,4,&5 ADDED.		

THE FOLLOWING CONDITIONS APPLY EXCEPT OTHERWISE STATED...

1. REF.TO HY0230261 FOR UNSPECIFIED TOLERANCES.
2. CHAMFER M/CD SHARP EDGES 1.2 TO 1.0 AT 45°.
3. INTERNAL M/CD CORNER RADII 1 TO 0.7.
4. THE SURFACE ROUGHNESS WHEREVER NOT SHOWN SHALL BE TAKEN FROM THE SURFACE ROUGHNESS SHOWN OUT SIDE BACK SLASHES GIVEN AT THE TOP MOST RIGHT CORNER OF THE DRG.

TYPE OF PRODUCT OR NAME OF CUSTOMER/PROJECT **883 XRP BOWL MILL**



BHARAT HEAVY ELECTRICALS LTD. HYDERABAD

DEPT. PULVE.ENGG	SCALE 1:30	WEIGHT (KG) 5117.00	REF. TO ASSY DRG. 0.61.388.00521	ITEM NO. 03	NO.OF ITEMS 09
CODE 446	TITLE PRESSING FOR SEPARATOR TOP		DRAWING NO. 3-61-388-02135	REV. 06	
			SHEET NO. 01	NO OF SHEETS 01	

NAME	SIGN.	DATE	NO.OF VAR.
DRN. RAZVI		1.10.03	
CHD. AMAN/NDS	<i>[Signature]</i>	1.10.03	
APPD. SGHATGE	<i>[Signature]</i>	1.10.03	