



ISO 9001:2000  
& 14001:2004  
MAHARATNA  
COMPANY

**MATERIAL MANAGEMENT (PURCHASE)**  
**CENTRAL FOUNDRY FORGE PLANT, BHEL HARDWAR**  
**RANIPUR, HARIDWAR (INDIA) – 249403**  
Phone No. 01334-281277/285635, FAX No. 01334-225892  
**e-mail : ranjank@bhelhwr.co.in, svn@bhelhwr.co.in**

**Sub: Tender Enquiry No: 3655 P/ 920/2/0763U2 due on 22/03/2013 at 2.00 PM (IST)**

Dear Sir,

We are pleased to invite offer as per enclosed specification with terms and conditions in sealed envelop for the under mentioned material.

Sl No	Tender No	Description of Material	Qty (MT)	Date & Time of Tender Opening
01	3655 P/ 920/2/0763U2	SUSPENSION ROD & NUT	28 NOS.	22/03/2013 at 2.00 PM (IST)

Kindly read terms and conditions carefully. Offer not submitted in accordance with the instructions is liable to be disqualified or ignored.

Please visit [www.bhel.com](http://www.bhel.com) or [www.bhelhwr.co.in](http://www.bhelhwr.co.in) for more details and tender documents.

Please also download Supplier Registration Form and submit same dully filled.

Thanking You,

Yours Faithfully,  
For & On behalf of CFFP BHEL Hardwar

(Ranjankumar)  
Sr.DGM (Purchase)

**Note: Corrigendum if any shall not be published, kindly visit web-site for any changes.**



निविदा सूचना  
**TENDER ENQUIRY**

AA-17001

भारत हेवी इलैक्ट्रिकल्स लिमिटेड

**Bharat Heavy Electricals Ltd**

सेन्ट्रल फाउन्ड्री फॉर्ज प्लांट- हरिद्वार - २४६४०३ (भारत)

**Central Foundry Forge Plant, Haridwar-249403 (INDIA)**

Phone : (0091) 01334- 281639,281385,285336

Fax : 01334 225892 / 226458

TIN NO. 05001763485  
C S T NO. HR-5018287 Dt. 16-03-1995

निविदा सूचना सं. ENQUIRY NO.*	3655 P/ 920/2/0763U2	दिनांक Date	01-03-2013
-------------------------------	----------------------	-------------	------------

कृपया निम्नलिखित के लिए निविदा दें। PLEASE QUOTE FOR THE FOLLOWING :

M/S. ::

DUEDATE

22-03-2013

::

Vendor Code

09285

INDIA

SL	MATERIAL CODE ITEM DESCRIPTION	QUANTITY	UNIT	LOTNO	LOT DELIVERY QTY SCHEDULE
----	-----------------------------------	----------	------	-------	------------------------------

1	FF9138090015 DRG: 01-GEN-141 REV: 03 FORGED FINISH MACHINED, SOLUTION ANNEALED CHARGE SUSPENSION DEVICE BOLTS WITH NUTS FITTED TOGETHER DULY ULTRASONICALLY TESTED TO CAT.II OF SPEC 0850118 .MATERIAL 304L.SPECIFICATION NO. FF04018. SPEC: FF04018 REV: 01	16	NO		
---	---	----	----	--	--

2	FF9531841403 DRG: THL-139 REV: 01 FORGED FINISH MACHINED, SOLUTION ANNEALED CHARGE SUSPENSION DEVICE BOLTS WITH NUTS FITTED TOGETHER DULY ULTRASONICALLY TESTED TO CAT.II OF SPEC 0850118 .MATERIAL 304L.SPECIFICATION NO. FF04018. SPEC: FF04018 REV: 01	12	NO		
---	--	----	----	--	--

\*\* IMPORTANT: This enquiry is 2 part tender. Techno-Commercial bid (Part-1) & Price Bids (Part-2) should be submitted in separate envelopes. These two envelopes should be submitted in a common sealed envelope. Techno-Commercial Bid shall contain detailed Technical Specification, Drawings Technical documents, Catalogues, taxes & duties, payment terms, delivery period, Validity of offer, Replica of Price Bid (Copy of price bid without price part) etc. The confirmation to the special terms & conditions must be submitted alongwith Techno-Commercial bid.

Standard Instructions:

TEST CERTIFICATE REQUIRED.

GUARANTEE CERTIFICATE REQUIRED.

PRE-INSP AT YOUR WORKS PRIOR DESP.

BASIC RATES, TAXES DUTIES SEPERATELY

CENVATABL DUPLICATE COPY OF INVOICE.



निविदा सूचना  
**TENDER ENQUIRY**

भारत हेवी इलेक्ट्रिकल्स लिमिटेड

**Bharat Heavy Electricals Ltd**

सेन्ट्रल फाउन्ड्री फॉर्ज प्लांट- हरिद्वार - २४६४०३ (भारत)

**Central Foundry Forge Plant, Haridwar-249403 (INDIA)**

Phone : (0091) 01334- 281639,281385,285336

Fax : 01334 225892 / 226458

TIN NO. 05001763485  
C S T NO. HR-5018287 Dt. 16-03-1995

निविदा सूचना सं. ENQUIRY NO.*	3655 P/ 920/2/0763U2	दिनांक Date	01-03-2013
-------------------------------	----------------------	-------------	------------

कृपया निम्नलिखित के लिए निविदा दें। PLEASE QUOTE FOR THE FOLLOWING :

MATERIAL CODE	QUANTITY	UNIT	LOTNO
ITEM DESCRIPTION			

## Special Instructions:

- Two Part Bid.
- Vendor will submit the manufacturing Plan.
- Vendor to furnish Inspection Certificate. Inspection can be anyone out of five viz. M/s BVQI, M/s LLOYD, M/s DNV, M/s TUV, M/s ALFRED H KNIGHT.
- Delivery will be one of the criteria for selecting the Vendor.
- The suspension nut and Bolts will be required in both VSF.
- PREQUALIFICATION CRITERIA IS MENTIONED ANNEXURE-1.

- =====
- (A) VALIDITY OF OFFER SHOULD BE MIN90 DAYS FROM DATE OF OPENING.
  - (B) OFFER MUST BE SUBMITTED STRICTELY IN LINE WITH SPECIFICATION, TERMS & CONDITIONS OF ENQUIRY ELSE OFFER MAY LIKELY BE IGNORED.
  - (C) ALL TAXES/DUTIES/LEVIIES ETC. MUST BE SPECIFIED SEPERATELY IN AMOUNT OR IN PERCENTAGE. INCOMPLETE OFFER SHALL NOT BE ACCEPTABLE.
  - (D) PLEASE QUOTE ON F.O.R. DESTINATION (CFFP/BHEL), FREIGHT PRE PAID BASIS ONLY.
  - (E) IN CASE VENDOR DO NOT ACCEPT CFFP,S PAYMENT TERMS AS PER ENQUIRY PROPER LOADING SHALL BE DONE
  - (F) FINAL INSPECTION AS PER BASED ON TC/GC OF THE PARTY WORKS
  - G) DULY FILLED & SIGNED WITH COMPANY SEAL"ANNEXURE-I TO BE SUBMITTED
  - (H) SPECIFICATION NO. 04018 REV 01 IS ENCLOSED.

## General Instructions:

1. Please submit authorization letter (format enclosed) for facilitating e-payment/electronic transfer of funds
  2. 100% payment within 30 days after receipt & acceptance of material at CFFP BHEL, Hardwar through e-payment.
  3. CFFP/BHEL RESERVES THE RIGHT TO PRE-INSPECT THE MATERIAL AT VENDOR'S WORKS / GODOWN/ PREMISES BEFORE DESPATCH.
  4. ORIGINAL MANUFACTURER'S TEST CERTIFICATE IS REQUIRED ALONG WITH DESPATCH DOCUMENTS. IN CASE SUPPLIES ARE FROM TRADERS, IT SHALL BE THE RESPONSIBILITY OF THE TRADER TO PROVIDE ORIGINAL MANUFACTURER'S TEST CERTIFICATE WITH LINKAGE TO TRADER'S INVOICE STATING BATCH NO.
  5. CFFP/BHEL Reserves the right to procure from more than one vendor.
  6. Please quote prices in figures & words both. In case the prices quoted in words and figures are different, the values indicated in words will be considered for evaluation & establishing Ll status.
- \* The offers of the bidders who are on the banned list as also the offers of the bidders, who engage the services of the banned firms, shall be rejected. The list of banned firms is available on web site [www.bhel.com](http://www.bhel.com)



D S RAWAT

ENGINEER ( PUR.)



संस्थान क्रय विनिर्देश  
(सी.एफ.एफ.पी. - हरिद्वार)  
**PLANT PURCHASE SPECIFICATION**  
(CFFP - HARDWAR)

**FF-04018 Rev 01**

पृष्ठ 1 का 2  
Page 1 of 2

**SPECIFICATIONS FOR SUSPENSION BOLT AND NUT**

**1.0 DESCRIPTION:**

Suspension bolts and nuts for Vertical Shaft Furnaces.

**2.0 OBJECTIVE:**

Suspension Bolts and Nuts are parts of Charge Suspension Device for Rotors and used in Heat Treatment Shop.

**3.0 SCOPE:**

Supply of the Suspension Bolts and Nuts in Forged, Solution treated & quenched and in machined condition.

**4.0 TECHNICAL REQUIREMENTS:**

4.1 Grade : ASTM A-182 F304L

4.2 Chemical Composition (As per Grade A-182 F304L):

Element	C	S	P	Si	Mn	Ni	Cr	Mo	V	Al
Min.	---	---	---	---	---	8.00	18.00	---	---	---
Max.	0.035	0.030	0.040	0.750	2.00	10.50	20.00	0.50		

\* Maximum Nitrogen content should be 0.10%.

4.3 Bolt forging should be one piece. The Head should be made by Forging, preferably by upset forging. Machining out the bolt from long cylindrical stock without forging of head as a step is not acceptable.

4.4 Heat Treatment [Solution treatment & quenching] shall be done as per Spec ASTM A-182 F304L.

4.5 Test piece samples for mechanical properties should be taken & tested from production forging (on prolongations). Test piece samples taken from separately forged test blanks are not acceptable. Mechanical Properties shall be as per Spec ASTM A-182 F304L.

4.6 Finished Forging should be machined as per drawing mentioned in the enquiry.

क्रय संकेत  
DATE

संस्थान  
INVENTORY NO





**COPYRIGHT AND CONFIDENTIAL**  
The information on this document is the property of Bharat Heavy Electricals Limited. It must not be used directly or indirectly in any way detrimental to the interest of the company.

संस्थान के अधिकार एवं गोपनीयता  
इस दस्तावेज़ में दी गई सूचना भारत भारती इलेक्ट्रिकल लिमिटेड की संपत्ति है। इस दस्तावेज़ को बिना अनुमति के किसी भी व्यक्ति को प्रकट नहीं किया जा सकता है।

संस्थान  
INVENTORY NO

अनुवादक TRANSLATED BY		
निर्मणकर्ता WORKED BY	P KALHAN	
जांचकर्ता CHECKED BY	SHAMEEM N V	
पर्यवेक्षणकर्ता SUPERVISED BY	A K KUSHWAH	
सहमत विभाग AGREED DEPTT	नाम NAME	दिनांक DATE
FORGE -QC	K CHAKRABORTY	
स्वीकृत APPROVED	संस्थान मानक समिति PLANT STANDARDS COMMITTEE	
तैयार PREPARED	जारी ISSUED	दिनांक DATE
FOUNDRY TECH	FORGE TECHNOLOGY	25-06--2012 25-06--2012



दिनांक एवं हस्ताक्षर SIGN & DATE		संस्थान क्रय विनिर्देश (सी.एफ.एफ.पी-हरिद्वार) <b>PLANT PURCHASE SPECIFICATION</b> (CFFP - HARDWAR)	<b>FF-04018 Rev 01</b> पृष्ठ 2 का 2 Page 2 of 2
SUPERVISOR'S INVENTORY NO सुपरिवाइजर का संयोजन संख्या	<p><b>4.7</b> The bolts and nuts must pass the following non Destructive Tests:</p> <ul style="list-style-type: none"> <li>(i) Ultrasonic Test as per Cat II of AA0850118</li> <li>(ii) Die Penetrant Test as per ASTM (no indications allowed)</li> </ul> <p>Acceptance shall be based upon chemistry, Heat Treatment record, Mechanical properties, Dimensions, UT and DP Tests. The necks of bolt heads must be free from tool marks and blended smoothly with the body of the bolts and the head.</p>		
COPYRIGHT AND CONFIDENTIAL The information on this document is the property of Bharat Heavy Electricals Limited. It must not be used directly or indirectly in any way detrimental to the interest of the company.	<p><b>5.0 GENERAL REQUIREMENTS:</b></p> <p><b>5.1 PACKING:</b> The Suspension Bolt and Nut shall be dispatched in packing with proper identification, to avoid any damage during handling, transit, and storage.</p> <p><b>5.2 GUARANTEE:</b> Guarantee Certificate for freedom from manufacturing defects to be furnished by the supplier.</p> <p><b>5.3 DOCUMENTS:</b> Three (3) sets of documents shall be supplied which includes:</p> <ul style="list-style-type: none"> <li><b>5.3.1</b> Ingot used for forging and Top and Bottom discards removed.</li> <li><b>5.3.2</b> Schematic forging sequence mentioning Reduction Ratio.</li> <li><b>5.3.3</b> Heat Treatment Cycle.</li> <li><b>5.3.4</b> Mechanical properties achieved.</li> <li><b>5.3.5</b> Test certificate and guarantee certificate for the equipment as a whole and test certificates of individual components</li> </ul>		
स्वत्वधिकार एवं गोपनीय : इस प्रलेख में कोई भी भाग हथौड़े इलेक्ट्रिकल्स की सम्पत्ति है इसका प्रत्यक्ष एवं अप्रत्यक्ष रूप से किसी भी तरह प्रयोग, जो की कंपनी के हित में हानिकारक हो न किया जाय।	<p><b>6.0 OTHER REQUIREMENTS:</b></p> <ul style="list-style-type: none"> <li><b>6.1</b> Offer should be clear in the all respects and accompanied by technical details of forging sequence and heat treatment.</li> <li><b>6.2</b> Vendor must confirm each clause of the specifications.</li> </ul> <p><b>7.0 REJECTION AND REPLACEMENT:</b></p> <ul style="list-style-type: none"> <li><b>7.1</b> The final decision regarding acceptance or rejection rests with BHEL, if the forging is not found as per specification or drawing at any time during further operation on the forging.</li> <li><b>7.2</b> The supplier shall replace the rejected forging at his own cost.</li> </ul>		
दिनांक एवं हस्ताक्षर SIGN & DATE	निर्माणकर्ता WORKED BY P KALHAN 	स्वीकृती APPROVED : 	संस्थान मानक समिति PLANT STANDARDS COMMITTEE निर्माण : फॉर्ज उत्पादन PREPARED : FORGE PROD. जारी : फॉर्ज टेक्नोलोजी ISSUED : FORGE TECHNOLOGY दिनांक : 25-06-2012 DATE : 25-06-2012
जांचकर्ता CHECKED BY INVENTORY NO	SHAMEEM 		



**SUSPENSION ROD (WT. 180 KG)**

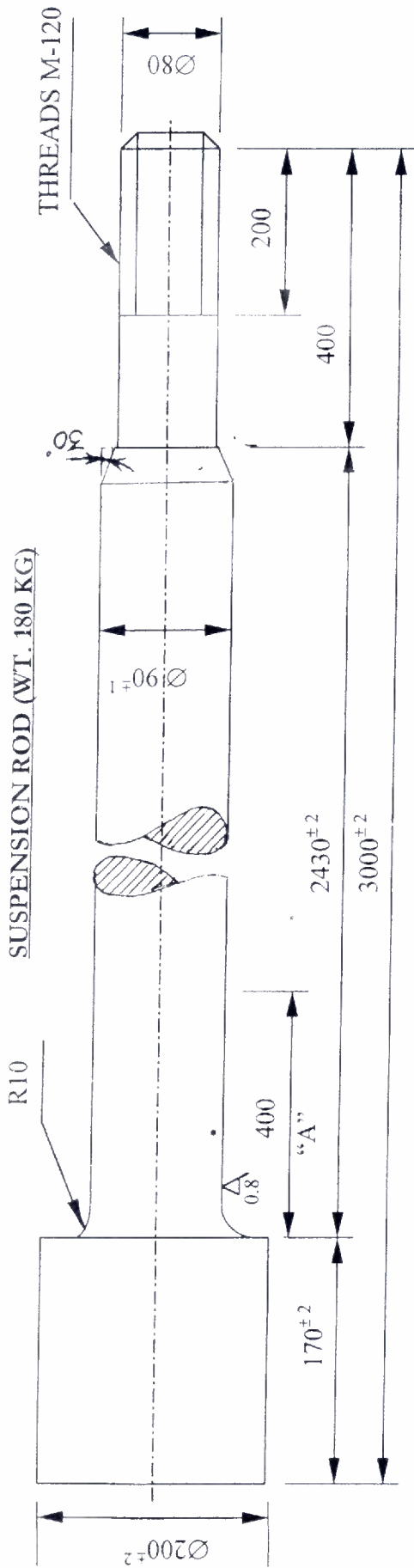

**NUT (WT. 30 KG)**

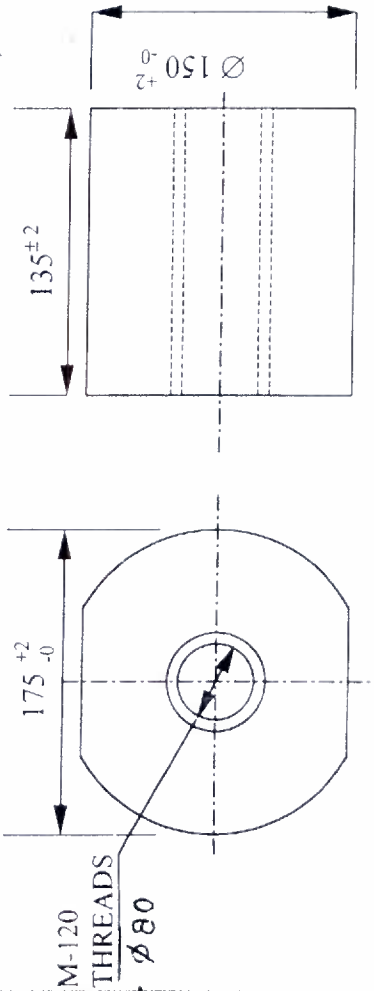

NOTE :-

(1.) FOR SUSPENSION ROD:-

TOLERANCE  $\pm 1$  UNLESS SPECIFIED  
 SURFACE FINISH: - ZONE "A" 0.8 $\mu$  &  
 ELSEWHERE 3.2 $\mu$

(2.) FOR NUT:-

TOLERANCE ON DIMENSIONS: +2.0  
 UNLESS SPECIFIED

NOTE: NUT AND SUSPENSION ROD TO BE FITTED TOGETHER

REV.	DATE	ALTERED	REV	DATE	ALTERED	AKK
		CHECKED	01	18/8/02	CHECKED	BPG

DRN	AKK	CHD	APP	BPG	COND.
					FINISHED M/C



**SUSPENSION  
 ROD & NUT**

W. O. C.F.P. INTERNAL

MATERIAL: SS 304 L

SCALE: N.T.S. WT. (180+30)KG

NAME: INTERNAL

DRG NO. ---

01-GEN-141

REV. 03

Commercial Terms

Item - Suspension Rod &amp; Nut

39

Confirmation/comments on the conditions given below are mandatory. Please confirm the following or else your offer is liable to be rejected.

	Description	Vendor Confirmation /Comment.
01	Material shall be supplied as per enquiry no <b>3655P/920/2/0763U2 dated 20.02.2013</b> in all respects without deviation.	
02	Guarantee / Test certificate required.	
03	Delivery shall be made on FOR Destination basis, destination being Stores/CFFP/BHEL Haridwar, Freight & Insurance charges to vendor's account.	
04	Payment Term: 100% within 30 days after receipt & acceptance (commissioning) of material at CFFP / BHEL, Haridwar through e-payment. Foreign Suppliers – Payment through USANCE L/C on 70 day from B/L date.	
05	Validity of offer: Minimum 90 days from tender opening date.	
06	Prices shall be firm till execution of Order.	
07	Provide name of contact person, mobile no. & email address.	
08	CFFP Reserves the right to open the price bid through Reverse Auction. Confirm your acceptance / participation.	
09	LATE DELIVERY PENALTY CLAUSE (LD) : Penalty for late delivery shall be applicable @ 0.5% per week and part thereof subject to a maximum of 10% for total P.O. value (Total material cost + packing and forwarding + freight) from the date of scheduled delivery of Purchase Order.	
10	Replica of price bid (without price part) required along with offer.	
11	For new vendors who are not registered with CFFP BHEL Haridwar, duly filled up "Supplier Registration Form" (available at www.bhel.com) along-with all the supporting documents has to be submitted along-with techno-commercial bid of offer. Please confirm that SRF is being submitted with your offer if applicable. However please note that if in any case duly filled up SRF along-with all the supporting documents is not received within 15 days of tender opening, your offer will liable to be ignored.	
12	Disputes: In event of any dispute arising out of contractual obligation, the order being finalized at Haridwar, India will be subject to Indian laws and falls under jurisdiction of the court of Law at Haridwar, India. The overseas supplier hereafter referred to as "Vendor" shall therefore abide by the verdict of court of Law at Haridwar, India.	
13	BHEL will prefer to deal directly with foreign vendor/ original manufacturer. In case, vendor engages any Indian agent or take service of any Indian agent, copy of agent agreement required along with offer in line with Annexure-IV attached.	
14	Pre-Qualification Criteria (P Q C): - Vendor should have supplied vertical shaft furnace of 40T or more capacity in past along with suspension device. OR Forging manufactures with forging facilities for forging & heat treatment. Please submit proof of prior supply of suspension bolt & nut or forgings in Grade A-182 F304L.	
15	- Delivery 60 days	

- 16 - In case any column is left blank, it shall be deemed to be accepted by vendor.
- If any difference is found for any term and condition in the offer and this annexure "A", the terms quoted in this annexure 'A' shall be deemed as final and binding on vendor.
  - Evaluation shall be on the basis of delivered cost (i.e.) "total cost to BHEL".

38

Date:

Signature with Seal of the Company.

GENERAL TERMS AND CONDITIONS OF TENDER ENQUIRY  
ANNEXURE-B

01 Submit the tender in two parts i.e.

- Part-I Techno-Commercial Bid**
- Part-II Price Bid**

Techno - Commercial (part one) Price Bid (part two) should be put in separate sealed envelopes. Both envelopes should be super scribed with **Tender Number, Date of opening & Technical / Commercial Bid and Price Bid** respectively along with name of firm.

Both the envelopes i.e. containing Techno-Commercial Bid and Price Bid should again be kept in one envelope super scribed again with Tender No. and Date of opening and the name of firm submitting the tender and send it to **AGM (MM), Purchase Department, CFFP/BHEL, Hardwar, Ranipur, Hardwar 249403, Uttarakhand, India before due date / tender opening date & time**. Normally tender opening time is 2.00 PM on due date or as mentioned in enquiry.

**Responsibility for submission of tender in time solely lies with vendor. Late offers received after specified time / Date shall not be considered.**

1. Part-I Envelopes super scribed with **Techno-Commercial Bid** must contain all information especially-
  - (a) Specification of the material offered should be strictly as per CFFP/BHEL specifications of enquired material in tender documents **Deviations if any must be indicated clearly in the offer. Rates to be quoted on For Destination Basis.**
  - (b) All commercial terms i.e. packing, forwarding Custom duty, Additional Duty, ST/STT/VAT/CST, Excise Duty/CVD, Bank charges, payment terms & insurance etc as applicable (**except price**) should be clearly mentioned in Techno-Commercial bid. Also mention present rate of applicable taxes & duties even if inclusive in rates along with the concessional forms required if any.
  - (c) Confirm to submit all required commercial documents (tax invoice centvatable duplicate copy of invoice, packing list, transit sale agreement etc.) & technical documents (TC/GC/QP etc).
  - (d) Registration Numbers of SSI, Central Excise, Sales tax, Income Tax, DGS & D.ECC etc.
  - (e) **Un-priced copy of Price Bid.**

Part-II Envelopes super scribed with Price Bid should contain priced copy of Price Bid. The price should be mentioned both in figures and words.

2. Authorized Signatory should authenticate all tender documents.
3. **Techno-commercial bid (Part-I)** will be opened on the due date at 2.00 PM in the presence of participating vendors or authorized representatives, who may wish to be present. Representative deputed to witness tender opening must produce an authority letter from the signatory of offer. After evaluation of technical bids & finalization of technical, commercial terms & conditions, price bid of only successful vendors will be opened. Priced bid opening date shall be intimated separately.
4. The material offered must conform to the required BHEL specifications and drawings as well as instructions and details made available.
5. For new vendors, Vendor Registration form duly filled must be submitted along with the offer which can be downloaded from our web site [www.bhel.com](http://www.bhel.com) or [www.bhelhwr.co.in](http://www.bhelhwr.co.in).
6. Original manufacturer's Test Certificate is required along with dispatch documents. In case supplies are from traders, it shall be the responsibility of the trader to provide original manufacturer's test certificate with linkage to traders invoice stating batch no.
7. **Validity** of offers should be minimum 90 working days from the date of tender (Techno-Commercial Bid) opening.

8. **Delivery** in the promised period is the essence of contract. Confirm to supply according to delivery schedule mentioned.

9. **Payment terms:**  
For indigenous suppliers: 100% within 30 days after receipt & acceptance of material at CFFP / BHEL, Haridwar through e-payment.  
For foreign suppliers: Payment through USANCE LC on 70<sup>th</sup> day of bill of lading date. All bank charges shall be to vendor's account.

\* In case vendor does not agree, proper loading shall be done. Also in that case, third party inspection shall have to be arranged by supplier from any of the five inspection agencies namely: LRS/ BVQI/ DNV/ TUV/ Alfred H.Knight at their cost.

10. CFFP/BHEL, Hardwar reserves the right to accept or reject any or all tenders without assigning any reason thereof.

11. Tenders not submitted in the prescribed manner are likely to be ignored / rejected.

12. Agent/Agency Commissioning: Payment of any kind at any stage will not be made to agent on account of agent commission or otherwise by CFFP/BHEL, Hardwar.

13. CFFP/BHEL, Hardwar may opt for E-auction/Reverse auction for obtaining best prices for part or full tendered quantity. BHEL also reserve the right to negotiate price with L1 vendor after reverse auction.

14. Please do intimate the personal contact details like Name, Mobile Number, Email-id etc of authorized executive for correspondence.

15. **Penalty:** Orders placed against this enquiry will be subject to normal clauses for imposing penalty. Liquidated Damages, Risk purchases, cancellation, arbitration as per terms and conditions of Tender Enquiry and Purchase orders in case of delay in effecting supply and/ or other defaults.

**Liquidated damage:** The delivery of the goods shall be made strictly as per time limit specified in delivery schedule, failure to supply within this period will make the supplier liable to an conditional penalty of 1/2 (half) percent of the price of the goods in arrears per week subject to a maximum of 10%.

16. **Inspection:** Final inspection of material shall be done after receipt of material at CFFP/BHEL, Hardwar. Acceptance of material shall be after final inspection and shall be binding. However, CFFP reserves the right to pre Inspect the material at supplier works. In case material is found defective during warranty period, the same will be returned for repair and/ or replacement. For this vendor has to bear all the charges such as Freight, to and fro insurance etc. Bank Guarantee for the equal amount to the cost of the item is to be furnished by vendor. In case the repair is done at CFFP/BHEL the amount on actual shall have to be reimbursed by the Vendor and or adjusted on actual from their bill.

17. **Currency of Payment:** Mention the currency in which payment has to be made. For evaluation of price bids, exchange rate (TT selling rate of SBI) as on scheduled date of tender opening (Part-1 bid in case of two part bid) shall be considered.

18. Traders should submit authorization letter from their principal alongwith offer.

19. Disputes: In event of any dispute arising out of contractual obligation, the order being finalized at Hardwar, India will be subject to Indian Laws and falls under jurisdiction of the court of Law at Haridwar, India. The overseas supplier hereafter referred to as "Vendor" shall therefore abide by the verdict of Court of Law at Hardwar, India.

OR

All disputes arising out of or in connection with the present contract, if any shall be finally settled under the rules of arbitration of International chamber of commerce by one or more arbitrator appointed in accordance with the said Rules in India.

20. BHEL reserves the right to place P.O. for part / full qty and on one or more than one sources.

21. Any Term & condition of the specific tender (if specified in tender & contradicts with above term) will supersede the above general terms & conditions.

**Terms and conditions regarding Indian agent of foreign suppliers:**

01. BHEL shall deal directly with foreign vendors, wherever required, for procurement of goods. However, if the foreign principal desires to avail of the services of an Indian agent, then the foreign principal should ensure compliance to regulatory guidelines- which require mandatory submission of an Agency agreement.
02. It shall be incumbent on the Indian agent and the foreign principal to adhere to the relevant guidelines of Government of India, issued from time to time.
03. The agency agreement should specify the precise relationship between the foreign OEM/Foreign principal and their Indian agent and their mutual interest in the business. All services to be rendered by agent/associate, whether of general nature or in relation to the particular contract, must be clearly stated by the foreign supplier / Indian agent. Any payment, which the agent or associate receives in India or aboard from the OEM, whether as commission or as a general retainer fee should be brought on record in the agreement and be made explicit in order to ensure compliance to laws of the country.
04. Any agency commission to be paid by BHEL to the Indian agent shall be in Indian currency only.
05. Tax deduction at source is applicable to the agency commission paid to the Indian agent as per the prevailing rules.
06. In the absence of any agency agreement, BHEL shall not deal with any Indian agent (authorized representatives/ associate/consultant, or by whatever name called) and shall deal directly with the foreign principal only for all correspondence and business purposes.
07. The "Guidelines for Indian Agents of Foreign Suppliers" enclosed at annexure- 'A' shall apply in all such cases.
08. The supply and execution of the Purchase Order (including indigenous suppliers/service) shall be in the scope of the OEM/ Foreign principal. The OEM/ Foreign principal should submit their offer inclusive of all indigenous suppliers/services and evaluation will be based on 'total cost to BHEL'. In case OEM/ foreign principal recommends placement of order(s) towards indigenous portion of supplies/services on Indian Supplier (s)/ agent on their behalf, the credentials/capacity/capability of the Indian Supplier (s)/ agent to make the supplies/Services shall be checked by BHEL as per the extant guidelines of Supplier Evaluation, Approval and Review Procedure (SEARP), before opening of price bids. In this regards, details may be checked as per Annexure- 'B' (copy enclosed). It will be the responsibility of the OEM/ Foreign Principal to get acquainted with the evaluation requirements of Indian supplier/agent as per SEARP available on [www.bhel.com](http://www.bhel.com).

The responsibility for successful execution of the contract (including indigenous supplies/services) lies with the OEM/ foreign principal. All bank guarantees to this effect shall be in the scope of the OEM/Foreign principal.

**Guidelines for Indian Agents of Foreign Suppliers**

- 1.0 There shall be compulsory registration of agents for all Global (Open) Tender and Limited Tender. An agent who is not registered with BHEL shall apply for registration in the registration form in line with SEARP.
  - 1.1 Registered agents will file an authenticated Photostat copy duly attested by a Notary Public/Original certificate of the Principal confirming the agency agreement and giving the status being enjoyed by the agent and the commission/ remuneration/ salary/ retainership being paid by the principal to the agent before the placement of order by BHEL.
  - 1.2 Wherever the Indian representatives have communicated on behalf of their principals and the foreign parties have stated that they are not paying any commission to the Indian agents, and the Indian representative is working on the basis of salary or as retainer, a written declaration to this effect should be submitted by the party (i.e. Principal) before finalizing the order.
- 2.0 Disclosure of particulars of agents/ representatives in India, if any.**
- 2.1 Tenderers of Foreign nationality shall furnish the following details in their offers:
    - 2.1.1 The Bidder(s)/ Contractor(s) of foreign origin shall disclose the name and address of the agents/ representatives in India if any and the extent of authorization and authority given to commit the Principals. In case the agent/ representative be a foreign Company, it shall be confirmed whether it is existing Company and details of the same shall be furnished.
    - 2.1.2 The amount of commission/ remuneration included in the quoted price(s) for such agents/ representatives in India.
    - 2.1.3 Confirmation of the Tenderer that the commission/ remuneration, if any, payable to his agents/ representatives in India, may be paid by BHEL in Indian Rupees only.
  - 2.2 Tenderers of Indian Nationality shall furnish the following details in their offers:
    - 2.2.1 The Bidder(s)/ Contractor(s) of Indian Nationality shall furnish the name and address of the foreign principals, if any, indicating their nationality as well as their status, i.e. whether manufacturer or agents of manufacturer holding the Letter of Authority of the Principal specifically authorizing the agent to make an offer in India in response to tender either directly or through the agents/ representatives.
    - 2.2.2 The amount of commission/ remuneration included in the price (s) quoted by the Tenderer for himself.
    - 2.2.3 Confirmation of the foreign principals of the Tenderer that the commission/ remuneration, if any, reserved for the Tenderer in the quoted price(s), may be paid by BHEL in India in equivalent Indian Rupees on satisfactory completion of the Project or supplies of Stores and Spares in case of operation items.
  - 2.3 In either case, in the event of contract materializing, the terms of payment will provide for payment of the commission/ remuneration, if any payable to the agents/ representatives in India in Indian Rupees on expiry of 90 days after the discharge of the obligations under the contract.
  - 2.4 Failure to furnish correct and detailed information as called for in paragraph 2.0 above will render the concerned tender liable to rejection or in the event of a contract materializing, the same liable to termination by BHEL. Besides this there would be a penalty of banning business dealings with BHEL or damage or payment of a named sum.

## Annexure-B

This format is applicable only to Indian Suppliers/ Agents supplying indigenous portion of Foreign Purchases.

\* In all other cases, extant guidelines of SEARP, 2010 are to be followed.

SEARP (SRF) Clause No	Detail
	<b>Name &amp; address of the firm</b>
<b>1.0</b>	<b>Products/ Systems / Services being considered for</b>
<b>2.0</b>	<b>General Information</b>
2.2	Name of Chief Executive
2.3	Details of authorized signatory
<b>3.0</b>	<b>Ownership Information</b>
3.1	Type of firm
3.2	Nature of Business <ul style="list-style-type: none"> <li>• Attach <b>authorization letter</b> and <b>agency agreement</b> from Principal ( from whom capital equipment is procured)</li> <li>• Attach copy of declaration from Foreign Principal for <b>total guarantee/ warranty of indigenous supplies</b></li> </ul>
3.3	Year of establishment
3.4	Year of commencement of business
<b>4.0</b>	<b>Registration particulars</b>
4.1	Permanent Account No.
4.2 / 4.3	Sales Tax / TIN no
4.6	Service tax no. (in case of E&C)
<b>5.0</b>	<b>Organisational strength</b>
<b>6.0</b>	<b>Other particulars</b>
6.1	If the company is already registered with other units
6.2	Directors/ Partners, if related to any BHEL Employee
6.9	If any Ex BHEL Personnel employed by the Company
6.12	Details of pending legal issues with BHEL
6.13	Bank Account information
<b>9.0</b>	<b>Financial information</b>
9.6	Sales/ Turnover details of last 3 years (or from the date of incorporation whichever is less )

---X---