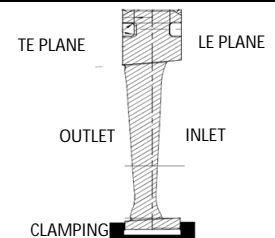
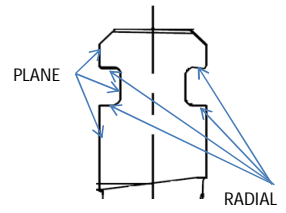
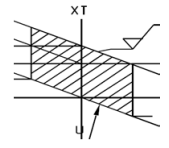

**PROCEDURE FOR 3DS\_GUIDE\_BLADE CMM INSPECTION**

HY/QC/CMM Inspection/3DS Guide Blades

Date: 10-12-2013

Prepared by : Ravinder Kumar

ACTIVITY	STEPS	DETAIL	ELEMENT NAME	NOTE
BLADE HOLDING CONDITION	STEP-1	BLADE SHROUD RESTS ON FIXTURE- BLADE VERTICAL	OPERATOR	
	STEP-2	TE PLANE PARALLEL TO X AXIS		
		TE END IN FRONT SIDE (TOWARDS OPERATOR)		
PRE-ALIGNMENT	STEP-1	MEASURE ROOT TE PLANE (6 POINTS MIN.)	PLA_TE	PROCEED ONLY IF FLATNESS $\leq 5\mu\text{M}$
	STEP-2	MEASURE ROOT LE PLANE (6 POINTS MIN.)	PLA_LE	
	STEP-3	MEASURE ROOT & SHROUD PRESSURE SIDE PLANE (6+4 POINTS MIN.)	PLA_PS	PROCEED ONLY IF FLATNESS $\leq 10\mu\text{M}$
	STEP-4	MEASURE ROOT BOTTOM PLANE (CONSIDER AS A PLANE) (4 POINTS MIN.)	PLA_BTM	
	STEP-5	CREATE A "MID PLANE" WITH TE & LE PLANE	PLA_MID_LE_TE	
	STEP-6	CREATE AN "AXI_PS_MID" WITH "PLA_MID_LE_TE" AND "PLA_PS" BY INTERSECTION	AXI_PS_MID	
	STEP-7	<b>BUILD "ROOT_CSY_PRE" :-</b> SPATIAL ALIGNMENT>AXI_PS_MID PLANAR ALIGNMENT>TE PLANE ORIGIN> X-AXIS, Y-MID PLANE, Z-BOTTOM PLANE	ROOT_CSY_PRE	
			SHIFT "ROOT_CSY_PRE" BY 15.06 IN X- DIRECTION ROOT_CSY_PRE1	
			NOTE:- CHECK COORDINATE SYSTEM MANUALLY	
FINAL ALIGNMENT	STEP-1	SCAN BOTTOM ROOT RADIUS (R701) FIND OUT "HIGHEST POINT"	ROOT_CSY	
	STEP-2	BUILD "ROOT_CSY" FINAL AND USE "HIGHEST POINT" FOR ORIGIN IN Z-DIRECTION		
	NOTE:-	CHECK COORDINATE SYSTEM MANUALLY		
ROOT MEASUREMENT	STEP-1	MEASURE ROOT SUCTION SIDE PLANE	PLA_SS	
	STEP-2	MEASURE ROOT TE SIDE ELEMENTS AS PER DRAWING		
	STEP-3	MEASURE ROOT LE SIDE ELEMENTS AS PER DRAWING		
	STEP-4	SHIFT Z ZERO BY BOTTOM RADIUS (R701) TOWARDS ROTOR CENTRE		
	STEP-5	SCAN-RADII ON ROOT eg:- R701-12=R689 AND R701-24=R677 BOTH TE & LE. (IF POINT SCANNING FACILITY NOT AVAILABLE ON CMM) MULTIPLE POINTS MEASUREMENT FOR R689 & 677 AT 1MM INTERVALS IN X, BOTH TE & LE.		
SHROUD MEASUREMENT	STEP-1	SHIFT 'Z' ZERO BACK TO ORIGINAL POINT SHIFT MEASURE ELEMENTS AS PER DRAWING	MEASUREMENT OF SHROUD-Pressure Side plane, Suction Side Plane, LE Plane & TE PLANE	
MEASUREMENT OF HEIGHT RELATED PARAMETER	STEP-1	MEASURE HEIGHT PARAMETER (TOTAL HEIGHT, S, D DIMENSIONS)		

PROFILE MEASUREMENT			
CREATE "Strak" FILE	STEP-1	CREATE A STRAK FILE IN .geo FORMAT, FOR DIFFERENT SECTION MEASUREMENT AND INSERT .geo FILE IN CMM SOFTWARE <b>Or</b> INSERT SPERATE SUCTION SIDE POINTS AND PRESSURE SIDE POINTS AS PER DRAWING	A(1), A(2), A(3) <b>OR</b> A_PS(1), A_SS(1), A_PS(2), A_SS(2), A_PS(3), A_SS(3)
	STEP-3	DISPLAY AND CHECK THE DATA WHETHER IT IS CORRECT OR NOT	
CREATE A "PROFILE CSY"	STEP-1	SHIFT 192MM "ROOT CSY" FOR PROFILE COORDINATE IN Z DIRECTION (R701-R509=192MM)	
PROFILE PRE ALIGNMENT	STEP-1	MEASURE POINT ON PROFILE FOR PROFILE PRE-ALIGNMENT	IF REQUIRED
	STEP-2	USE POINTS FOR PROFILE PRE ALIGNMENT	
MEASUREMENT OF PROFILE	STEP-1	MEASURE PROFILE FOR EACH CHECKING SECTION BY USING "ScanOnCurve (known path)" COMMAND FOR BOTH PRESSURE & SUCTION SIDE SEPARATELY.	
	STEP-2	MERGE THE PRESSURE AND SUCTION SIDE PROFILES.	

**REPORT-PROTOCOL(SHROUD & ROOT PARAMETER)**

GENERATE PLANE FOR DIFFERENT SECTION & VIEW EVALUATION	FOR SECTION DD AND VIEW-X EVALUATION
<p><b>EVALUATION OF SECTION DD</b>:- SHROUD PITCH, SHROUD HALF PITCH, PRESSURE SIDE RHOMBOID ANGLE, SUCTION SIDE RHOMBOID ANGLE AND ALL OTHER PARAMETERS SHOWN IN SKETCH (VIEW-DD)</p>	
<p><b>EVALUATION OF VIEW-X</b>:- ROOT PITCH, ROOT HALF PITCH, PRESSURE SIDE RHOMBOID ANGLE, SUCTION SIDE RHOMBOID ANGLE AND ALL OTHER PARAMETERS SHOWN IN SKETCH (VIEW-X)</p>	

**EVALUATION OF SECTION BB & TAPER ANGLE :-**

**EVALUATION OF SECTION BB:-**

FOOT DIM (12-0.1), FOOT RADIALITY (PERPENDICULARITY & CYLINDRICITY WITHIN 0.05)  
 ROOT GROOVE (12+0.1), NECK DIM, ROOT WIDTH, SHROUD WIDTH, ROOT OFFSETS,  
 SHROUD OFFSETS, OTHER DIMENSIONS EVALUATION AS PER SKETCH DRAWING.  
 EVALUATION OF TAPER ANGLE (2.616)

**CRITICAL REQUIREMENT (REFER STEP 5 OF 'ROOT MEASUREMENT'):-**

- (1)
  - a) RANGE OF DISTANCES OF R677 (TE & LE ) MEASURED POINTS, FROM ROTOR ZERO ,SHALL BE WITHIN 0.05MM
- (2)
  - a) LIST DISTANCES OF ALL TE & LE R689 MEASURED POINTS FROM ROTOR ZERO
  - b) FIND |MAX-MIN| OF ALL DISTANCES ..... SHALL BE  $\leq 0.05$ MM
  - c) ALL R689 ACTUAL DISTANCES SHALL BE  $689 \pm 0.1 / -0.0$
- (3)
  - a) LIST DISTANCES OF ALL TE & LE R677 MEASURED POINTS FROM ROTOR ZERO
  - b) FIND MAX & MIN R689 AND MAX & MIN R677
  - c)  $(R689_{max} - R677_{min})$  AND  $(R689_{min} - R677_{max})$  SHOULD BE WITHIN  $12 \pm 0.1 / -0.00$
- (4) REPORT FOOT DIM 12-0.1 AT LE AND TE (THIS CORRESPOND TO MEASURED R689 AT X=0;; (+) IN R689 WILL BE REPORTED AS (-) IN 12-0.1 I.E. MEASURED DISTANCE 689.05 WILL BE REPORTED AS 11.95)

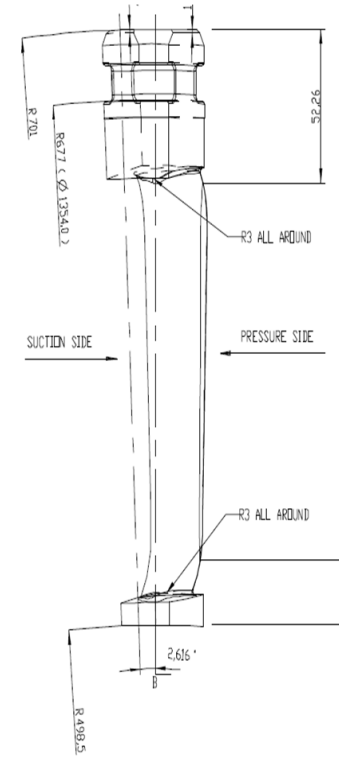
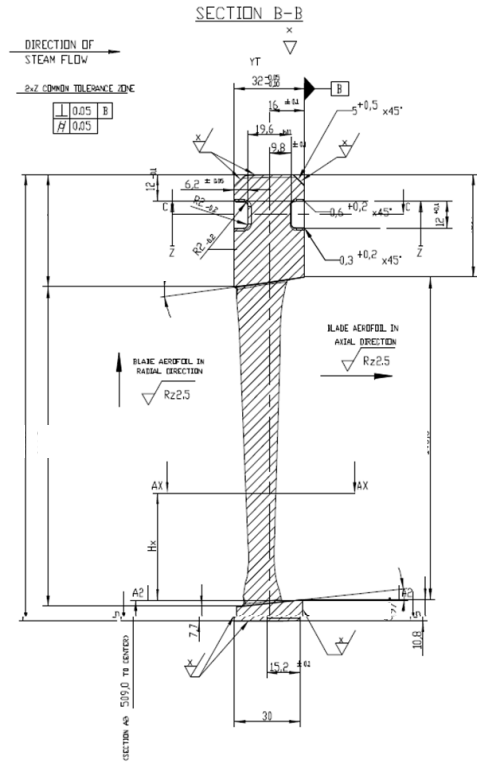

**EVALUATION OF TOTAL HEIGHT, S, D DIMENTIONS:-**

EVALUATION OF TOTAL HEIGHT, S, D DIMENSIONS ON PRESSURE SIDE & SECTION SIDE HEIGHT

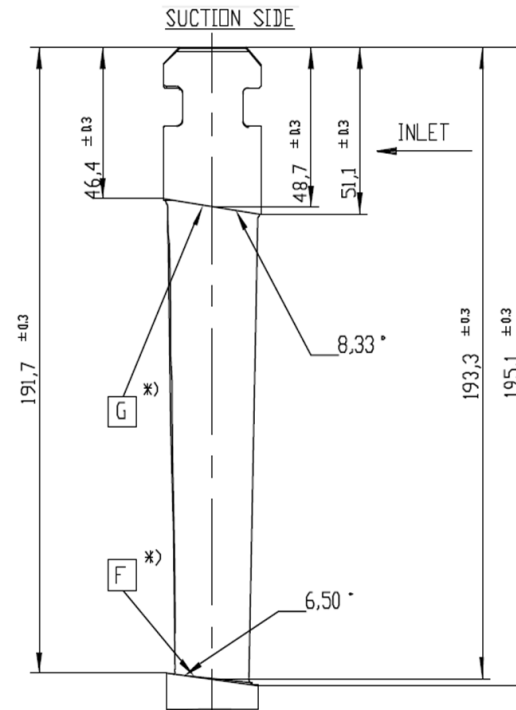
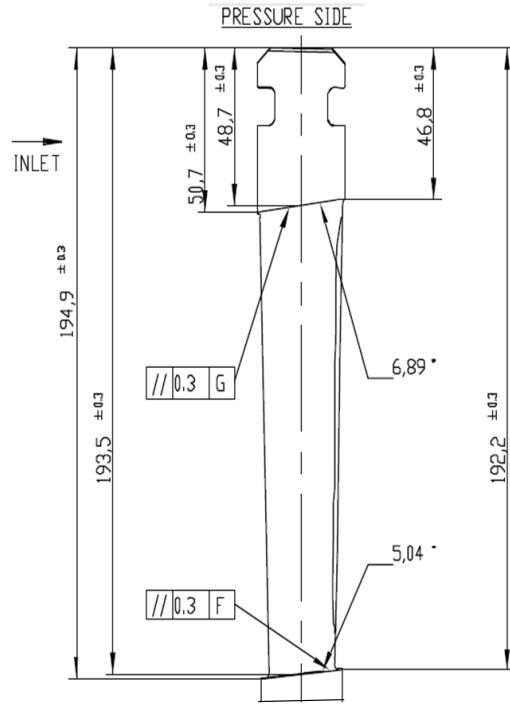

**REPORT-PLOT(PROFILE):-**

REPORT POINT-WISE "PROFILE" DEVIATION (NOT X, Y DEVIATION)  
& DRAW PLOT BEFORE BEST FIT ACTUAL/NOMINAL POINTS PROFILE

MAX. DEVIATION AND MIN. DEVIATION WITH LOCATION

REPORT POINT-WISE "PROFILE" DEVIATION AFTER BEST FIT (TOLERANCE ±0.05)  
& DRAW PLOT AFTER BEST FIT ACTUAL/NOMINAL POINTS PROFILE

MAX. DEVIATION AND MIN. DEVIATION WITH LOCATION

EVALUATION OF PROFILE SECTIONS

MAX. THICKNESS CIRCLE(D), CHORD LENGTH LE-TE, TRAILING EDGE THICKNESS

OBSERVATION OF PROFILE SHIFT IN X & Y , AND ROTATION ANGLE OF PROFILE FOR EACH CHECKING SECTION