



ISO 9001:2008,
14001:2004,
50001:2011 &
OHSAS 18000
MAHARATNA
COMPANY

MATERIAL MANAGEMENT (PURCHASE)
CENTRAL FOUNDRY FORGE PLANT, BHEL HARDWAR
RANIPUR, HARIDWAR (INDIA) – 249403
Phone No.+91-1334-281277/284684, FAX No. 225892
e-mail : v_kumar@bhelhwr.co.in; anuragkk@bhelhwr.co.in;
ranjank@bhelhwr.co.in

Sub: Open Tender Enquiry No: 201602481/4116 due on 05.09.2016, at 2.00 PM

Dear Sir,

We are pleased to invite offer in **E-Tender** as per enclosed specifications & terms and conditions for the under mentioned items.

SI No	Tender No	Description of Material	Qty	Date & Time Of Opening
1	201602481/4116	Material Code: FF6942076040 Guide Pads for Trepanning Drg. No. 04-02-076 SIZE: Dia 111-161.90 mm	100 Nos.	05.09.2016
2		Material Code: FF6942009016 Guide Pads for Counter Boring Head Drg. No. 04-02-009 SIZE: Dia 250 mm	50 Nos.	

Kindly read terms and conditions, Offer not in accordance with the instructions is liable to be disqualified or ignored.

Please visit www.bhel.com or www.bhelhwr.co.in for more details & corrigendum if any for the tender enquiry. Offers are to be submitted online in E-tender portal at <https://bheleps.buyjunction.in/>

Offer to be submitted only on e-procurement portal. Hard copy of offer is not required to be submitted to CFFP. Any offers received in Hard copy shall not be accepted and straightaway rejected by CFFP.

Before proceeding for submitting quotation in e-portal, supplier to ensure that they are having a valid Digital Signature Certificate (DSC). Valid DSC refers to an Active Signing and Encryption Certificate (both), with specification Class III SHA2 2048 bit

Unregistered vendors should download Vendor Registration Form and submit same duly filled along with offer.

Thanking You,

Yours Faithfully,
For & On behalf of CFFP, BHEL, Hardwar

(Vipin Kumar)
Engineer (Purchase)

Note: Corrigendum if any shall not be published, kindly refer websites for any changes.

ENQUIRY NO. 201602481/4116

Pre-Qualifying Conditions :

<u>SL.NO.</u>	<u>REQUIREMENT TO BE COMPLIED</u>	<u>VENDOR'S CONFIRMATION</u>
1	Only those vendors to quote who are Original tool manufacturer or authorized dealer/distributor of Original tool manufacturer. Authorization certificate from Original tool manufacturer to be furnished by the vendor with the offer.	VENDOR TO CONFORM AND SUBMIT NECESSARY DOCUMENTS
2	Vendor should have supplied minimum 50 Nos. of Guide Pads of length 30mm or more for Boring application purpose in any 1 financial year from financial year 2011-12 till the date of opening of tender.	VENDOR TO CONFORM AND SUBMIT P.O. COPIES
	The following information is to be submitted by the participating vendor about the companies where such type of Indexable Milling Cutters have been supplied. This is required from all the vendors for qualification of their offer.	
2.a	Name and address of the customer / company where such Guide Pads have been supplied.	VENDOR TO PROVIDE DETAIL
2.b	Name, designation, phone no. & email address of the contact person of the customer.	VENDOR TO PROVIDE DETAIL
2.c	Purchase Order Detail, Month & Year of supply	VENDOR TO PROVIDE DETAIL
2.d	Basic details of supplied Guide Pad like Length,width,height etc.	VENDOR TO PROVIDE DETAIL
2.e	The participating vendor should provide performance certificate of Guide Pads used for Boring application, supplied to referred customer. (Original certificate or copy or through Email directly from the customer). In case vendor submits copy of performance certificate, then vendor has to bring the original certificate to CFFP for authentication during evaluation stage and thereafter vendor can take back the original certificate	VENDOR TO CONFORM AND SUBMIT PERFORMANCE CERTIFICATE
2.f	BHEL reserves the right to verify the information provided by vendor. In case the information provided by vendor is found to be false/ incorrect, the offer shall be rejected.	VENDOR TO NOTE

ITEM:-GUIDE PAD FOR BORING APPLICATION

Supply & Successful establishment of Guide pad (for Boring Operation) of Boring range:- for Item no.-1- 111-161.9 mm, For item No. 2- 250mm as per Drg No. 04-02-076 & 04-02-009 respectively, on Jobs(Having Hardness upto 350 BHN) by using Trepanning Heads and Counter Boring Heads respectively as available in Machine Shop,CFFP BHEL Haridwar on Deep Hole Boring Machine :

POINT NO.	REQUIREMENT TO BE COMPLIED	VENDOR'S CONFIRMATION
1	The vendor to offer Guide pad (for Boring Operation) of Boring range;for Item no.-1 111-161.9 mm, For item No. 2- 250mm as per Drg No. 04-02-076 & 04-02-009 respectively to be used with Trepanning Heads and counter Boring Heads respectively as available in Machine Shop,CFFP BHEL Haridwar on Deep Hole Boring Machine meeting acceptance criteria as specified at point no.	VENDOR TO CONFORM
2	Quantity : Vendor to offer for following items	VENDOR TO CONFORM
	ITEM NO. ITEM DETAIL Qty.	
	1 Guide Pad for Boring range 111-161.9 as per Drg No. 04-02-076 100	VENDOR TO CONFORM
2 Guide Pad for Boring Ø 250mm as per Drg No. 04-02-009 50	VENDOR TO CONFORM	
3	Offered items will be tried on Jobs (Having Hardness upto 350 BHN) for Trepanning & Counter Boring Operations respectively. Therefore offered items should have proper carbide TIP, Brazing of TIP, Shank,Finish to meet following operational criteria:- Item no. 1 will be used at at RPM upto 120 rev/min,feed 5-6 mm/min, average life obtained by single tool needs to be min. 10M. Item no. 2 will be used at at RPM upto 120 rev/min,feed 5-6 mm/min, average life obtained by single tool needs to be min.	VENDOR TO CONFORM
4	L1 status shall be evaluated separately for both item no. 1,2. Item no. 1,2 will be procured from L-1 vendor only .	VENDOR TO CONFORM
5	Item no.1 is used with trepanning Head of Dia 115mm and 134mm while item no. 2 is used with counter boring head of Dia 250mm on Deep Hole Boring Machine with through coolant arrangement. Offered item works on BTA principle. Final acceptance shall be given by BHEL after successful establishment of supplied item by the vendor at BHEL, CFFP Haridwar by carrying out Boring operations with the help of trepanning head for item no. 1 and Counter Boring Head for item no. 2 with supplied items conforming to requirement as mentioned at Point No. 4,5, failing which will lead to item rejection. During establishment period, supplied Guide pad should not damage till speified Boring length as mentioned at point no. 4. The above machining shall be carried out on FUJIEI SEIKI make Deep Hole Boring Machine on mutually agreed schedule as per availability of component & machine(Maximum 1 month time from the date of receipt of item to carry out operation). Vendor may depute their representative at the time of establishment.	VENDOR TO CONFORM
6	If the item could not be established in one go, the vendor will be given one more chance to improve upon and establish the machining through change of Item. In case of failure even in second chance, the supplied lot for concerned item shall be declared as rejected.	VENDOR TO CONFORM
7	The payment shall be made subject to final acceptance by BHEL after successful establishment of supplied items by the vendor as per Final acceptance criteria mentioned above at point no. 3,4.	VENDOR TO CONFORM
8	The offer should be complete having list & quantity of each item offered with separate price bid. In case, vendor requires any clarification, they may discuss with BHEL prior to submission of their offer to avoid any gaps at later stage.	VENDOR TO CONFORM AND SUBMIT NECESSARY DOCUMENTS
9	In case of damage to any item during establishment of required machining due to wrong item supplied, the same shall be replaced by the vendor without any financial implications to BHEL.	VENDOR TO CONFORM
10	Guarantee Certificate required with minimum guaranty period of 12 months from the date of acceptance of material.	VENDOR TO CONFORM

BORING RANGE
 ϕ 50 - ϕ 85

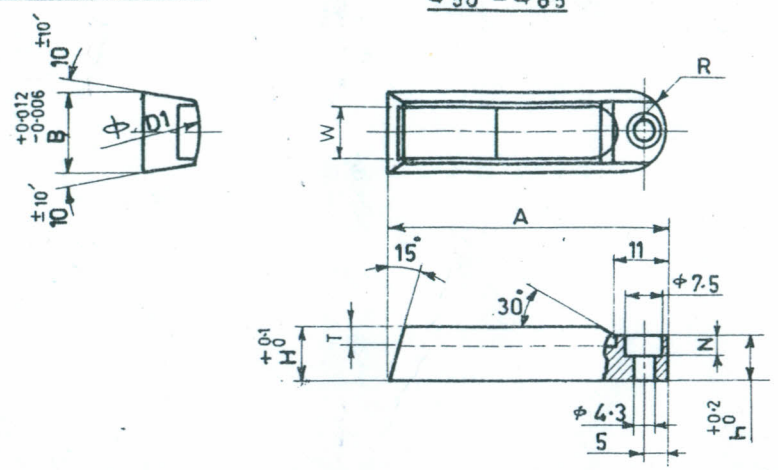

ϕ 86.1 OR LARGER

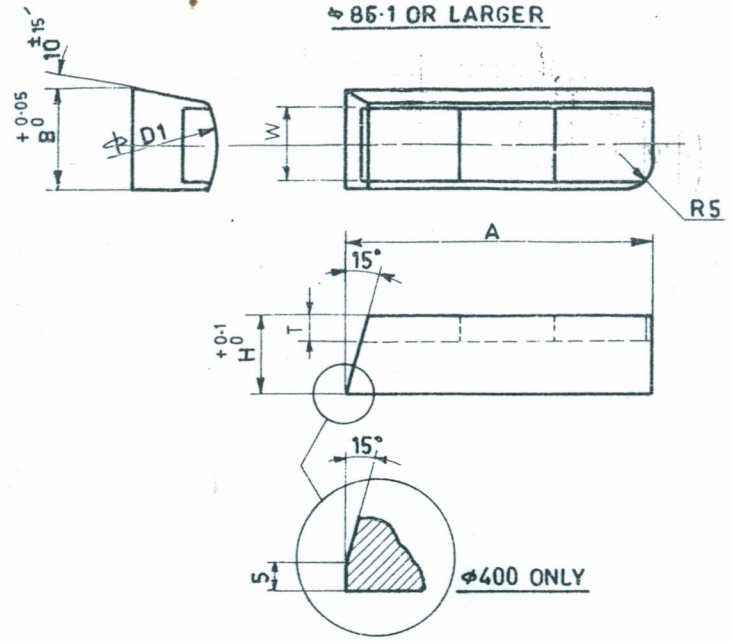

DIMENSION 'H' HAS CYLINDRICAL GRINDING SURPLUS.
GRADE OF CARBIDE TIPS ARE ISO P20
SHANK MATERIAL IS CARBON STEEL C 30
SAND WICH BRAZED WITH 0.3MM COPPER PLATE.

TOLERANCES \pm 0.25
UNLESS OTHERWISE STATED.

BORING RANGE	ϕ D1	B	A	H	h	N	R	W	T
55-65.9	66.9	14	50	9.3	7.5	4	7	8	3
66-85.9	86.9	16	55	10.8	9.0	4.5	8	10	3
86-110.9	111.9	17	55	12.8	-	-	-	12	5
111-161.9	162.9	20	60	15.8	-	-	-	14.5	5
162-257.9	258.9	22	65	17.8	-	-	-	16	6
ϕ 400	401	34	77.5	25.3	-	-	-	25.5	8

				TREPPANNING GUIDE PADS		04-02-076		
						CODE	WEIGHT	SCALE
						NTS		
DRAWN	MISHRA	SIGN	DATE	11-8-82		SHEET 1 TOTAL SHEETS 1		
CHECKED	PANGLI			16-8-82		C.F.F.P. M/C SHOP		
APPROVED								

DIA. 70 OR LARGER

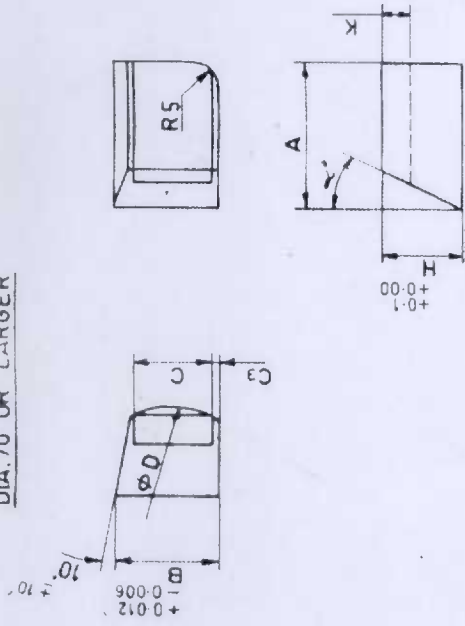

$\phi 47 - \phi 70$

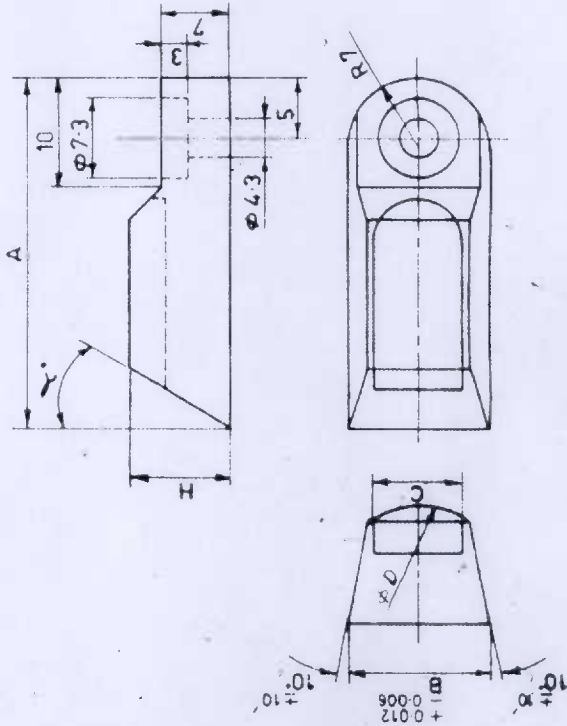

DIMENSION 'H' INCLUDE CIRCLE GRINDING SURPLUS.
 CARBIDE TIP GRADE IS IS0 P20
 SHANK MATERIAL- S55 C
 CARBIDE BIT 'C' MUST BE RIGIDLY LOCATED IN SLOT.

TOLERANCES ± 0.25 MM
 UNLESS OTHERWISE STATED.

NOTE - DIMENSION FOR SIZE 150 INCORPORATED.

BORING ϕ IN MM	ϕ D	B	A	C	C3	H	α	K
400	401	35	62	25	2	21.8	28°	8
250	251	30	51	23	1	20.3	20°	8
150	151	20	31	14.8	1	15.5	20°	7
127	128	20	31	14.8	1	14.8	30°	6
115	116	20	31	14.8	1	17.8	20°	6
110	111	20	31	14.8	1	15.3	25°	6
101.6	102.6	16	29	12	1	11.6	30°	5
100	101	16	29	12	1	10.8	30°	5
80	81	16	29	12	1	11.3	30°	5
63.5	64.5	14	35	9		9.55	30°	5
50	51	14	35	9		9.8	30°	4

		NAME	SIGN	DATE
DRAWN	BY	KA RAO		
CHECKED	BY			
APPROVED	BY			

GUIDE PADS
 FOR
 COUNTER BORE

01-02-009

COPIES	WEIGHT	SCALE
SHEETS	TOTAL SHEETS	M/C SHOP

GENERAL TERMS AND CONDITIONS OF TENDER ENQUIRY THROUGH E-TENDER

CFFP/TE/GTC/E R00 DT:07.03.2016

1. Offer to be submitted only on e-procurement portal. Hard copy of offer is not required to be submitted to CFFP. Any offers received in Hard copy (for E-Tender Enquiries) shall not be accepted and straightaway rejected by CFFP.
2. Responsibility for submission of tender in time solely lies with vendor. Vendors are requested to submit offers well in advance of due date & time.
3. Foreign template (for offer submission) to be selected only by Foreign vendor on whom order is to be placed. Offers submitted by Indian/Indigenous vendors in foreign template shall not be accepted for that enquiry.
4. Price to be quoted only in UNIT as mentioned in enquiry for that item.
5. Vendor to specify details of product offered and attach any technical literature/ data sheet/ drawing as applicable for the product offered.
6. Offer must be submitted strictly in line with specification, terms & conditions of enquiry else offer is likely to be ignored. Deviations if any to be indicated clearly in the spaces provided for deviations.
7. All commercial terms i.e. packing & forwarding, Custom duty, Additional Duty, VAT/CST, Excise Duty/CVD. Bank charges, Freight, payment terms & Insurance etc if any as applicable must be specified correctly in amount or in percentage in respective fields.
8. Evaluation for L1 status shall be done on basis of Landed cost net of Cenvat at CFFP.
9. Standard Payment terms:
For indigenous suppliers: 100% within 30 days after receipt & acceptance of material at CFFP / BHEL, Haridwar through e-payment.
For foreign suppliers: Payment through USANCE LC on 70th day of bill of lading date. Bank charges - Either Side (i.e. in India to BHEL account & in Beneficiary country to Vendor's account). In case of amendment to LC for reasons attributable to vendor, all bank charges (both sides) shall be to Vendor's account.
10. In case VAT is applicable, VAT to be charged extra without any concessional form. VAT amount shall be released / paid to vendor after having obtained a confirmation (copy of Challan) that VAT amount has been paid to the Uttarakhand Commercial Tax Department.
11. In case CST is applicable, CST to be charged extra against form C.
12. Original manufacturer's Test Certificate is required along with dispatch documents. In case supplies are from traders, it shall be the responsibility of the trader to provide Original manufacturer's test certificate with linkage to traders invoice stating batch no.
13. CFFP/BHEL, Haridwar reserves the right to reject any or all tenders without assigning any reason thereof.
14. BHEL reserves the right to place PO for part / full qty.
15. BHEL reserves the right to place PO on more than one source as specified in splitting condition of tender enquiry (if applicable for that enquiry).
16. In case Foreign vendor takes services of an Indian Agent, Agency Agreement to be compulsorily submitted alongwith offer. In absence of Agency Agreement, BHEL shall not deal with Agent and shall deal directly with Foreign Principal. Role and scope of work/services rendered by Indian Agent alongwith agency commission of Agent to be clearly specified in Agreement.
17. CFFP/BHEL, Haridwar may opt for E-auction/Reverse auction for obtaining prices for part or full tendered quantity. BHEL also reserve the right to negotiate price with L1 vendor after reverse auction.
18. In case vendor is not registered with CFFP BHEL Haridwar for this material, duly filled 'Supplier Registration Form' must be submitted within 15 days of opening of tender (form available on website www.bhelhwr.co.in & www.bhel.com).

GENERAL TERMS AND CONDITIONS OF TENDER ENQUIRY THROUGH E-TENDER

CFFP/TE/GTC/E R00 DT:07.03.2016

19. EMD/Security Deposit/ Tender fees shall be as specified in tender enquiry (if applicable for that enquiry).
20. Offers of the bidders who are on the banned list as also the offers of the bidders, who engage the services of the banned firms shall be rejected. The list of banned firms is available on website www.bhel.com
21. Inspection: Final inspection of material shall be done after receipt of material at CFFP/BHEL, Hardwar. Acceptance of material shall be after final inspection and shall be binding. However, CFFP reserves the right to pre inspect the material at supplier works. In case material is found defective during warranty period, the same will be returned for repair and/ or replacement. For this vendor has to bear all the charges such as Freight, to and fro insurance etc. Bank Guarantee for the equal amount to the cost of the item is to be furnished by vendor. In case the repair is done at CFFP/BHEL the amount on actual shall have to be reimbursed by the Vendor and or adjusted on actual from their bill.
22. The Bidder along with its associate/ collaborators/ sub-contractors/ sub-vendors/ consultants/ service providers shall strictly adhere to BHEL Fraud Prevention Policy displayed on BHEL website <http://www.bhel.com> and shall immediately bring to the notice of BHEL Management about any fraud or suspected fraud as soon as it comes to their notice.
23. Currency of Payment: Mention the currency in which payment has to be made. For evaluation of price bids, exchange rate (TT selling rate of SBI) as on scheduled date of tender opening (Part-1 bid in case of two part bid) shall be considered.
24. Agent/Agency Commission: Payment of any kind at any stage will not be made to agent on account of agent commission or otherwise by CFFP/BHEL, Hardwar.
25. In case of rejection of material after receipt at CFFP, vendor / supplier is required to take back the rejected material at their cost within 45 days from the date of rejection memo / note. If vendor/ supplier fails to take back the rejected material from CFFP within 90 days from the date of rejection memo / note, CFFP has the right to dispose-off the rejected material at the risk & cost of the vendor / supplier and no further claim for the rejected material will be entertained.
26. Penalty for late delivery: The delivery of the goods shall be made strictly as per time limit specified in delivery schedule of purchase order, failure to supply within this period will make the supplier liable to penalty of 1/2 (half) percent of the price of the goods in arrears per week subject to a maximum of 10%.
In case of non-acceptance or partial acceptance, offer shall be loaded for the unaccepted portion (out of the maximum 10% penalty) to calculate landed cost.
27. Risk Purchase: In case of delayed/defective supplies or non-fulfilment of any other terms & conditions given in the Purchase Order, the purchaser may cancel the purchase order in full or part thereof and may also make the purchase of such material at the risk & cost of supplier.
28. Disputes: In event of any dispute arising out of contractual obligation, the order being finalized at Hardwar, India will be subject to Indian Laws and falls under jurisdiction of the court of Law at Haridwar, India. The overseas supplier shall also abide by the verdict of Court of Law at Hardwar, India. OR
All disputes arising out of or in connection with the present contract, if any, shall be finally settled under the rules of arbitration of International chamber of commerce by one or more arbitrator appointed in accordance with the said Rules in India.
27. Any Term & condition of the specific tender (if specified in tender & contradicts with above term) will supersede the above general terms & conditions.

Terms and conditions regarding Indian agent of foreign suppliers:

01. BHEL shall deal directly with foreign vendors, wherever required, for procurement of goods. However, if the foreign principal desires to avail of the services of an Indian agent, then the foreign principal should ensure compliance to regulatory guidelines- which require mandatory submission of an Agency agreement.
02. It shall be incumbent on the Indian agent and the foreign principal to adhere to the relevant guidelines of Government of India, issued from time to time.
03. The agency agreement should specify the precise relationship between the foreign OEM/Foreign principal and their Indian agent and their mutual interest in the business. All services to be rendered by agent/associate, whether of general nature or in relation to the particular contract, must be clearly stated by the foreign supplier / Indian agent. Any payment, which the agent or associate receives in India or aboard from the OEM, whether as commission or as a general retainer fee should be brought on record in the agreement and be made explicit in order to ensure compliance to laws of the country.
04. Any agency commission to be paid by BHEL to the Indian agent shall be in Indian currency only.
05. Tax deduction at source is applicable to the agency commission paid to the Indian agent as per the prevailing rules.
06. In the absence of any agency agreement, BHEL shall not deal with any Indian agent (authorized representatives/ associate/consultant, or by whatever name called) and shall deal directly with the foreign principal only for all correspondence and business purposes.
07. The "Guidelines for Indian Agents of Foreign Suppliers" enclosed at annexure- 'A' shall apply in all such cases.
08. The supply and execution of the Purchase Order (including indigenous suppliers/service) shall be in the scope of the OEM/ Foreign principal. The OEM/ Foreign principal should submit their offer inclusive of all indigenous suppliers/services and evaluation will be based on 'total cost to BHEL'. In case OEM/ foreign principal recommends placement of order(s) towards indigenous portion of supplies/services on Indian Supplier (s)/ agent on their behalf, the credentials/capacity/capability of the Indian Supplier (s)/ agent to make the supplies/Services shall be checked by BHEL as per the extant guidelines of Supplier Evaluation, Approval and Review Procedure (SEARP), before opening of price bids. In this regards, details may be checked as per Annexure- 'B' (copy enclosed). It will be the responsibility of the OEM/ Foreign Principal to get acquainted with the evaluation requirements of Indian supplier/agent as per SEARP available on www.bhel.com.

The responsibility for successful execution of the contract (including indigenous supplies/services) lies with the OEM/ foreign principal. All bank guarantees to this effect shall be in the scope of the OEM/Foreign principal.

Guidelines for Indian Agents of Foreign Suppliers

- 1.0 There shall be compulsory registration of agents for all Global (Open) Tender and Limited Tender. An agent who is not registered with BHEL shall apply for registration in the registration form in line with SEARP.
- 1.1 Registered agents will file an authenticated Photostat copy duly attested by a Notary Public/Original certificate of the Principal confirming the agency agreement and giving the status being enjoyed by the agent and the commission/ remuneration/ salary/ retainership being paid by the principal to the agent before the placement of order by BHEL.
- 1.2 Wherever the Indian representatives have communicated on behalf of their principals and the foreign parties have stated that they are not paying any commission to the Indian agents, and the Indian representative is working on the basis of salary or as retainer, a written declaration to this effect should be submitted by the party (i.e. Principal) before finalizing the order.
- 2.0 **Disclosure of particulars of agents/ representatives in India, if any.**
- 2.1 Tenderers of Foreign nationality shall furnish the following details in their offers:
 - 2.1.1 The Bidder(s)/ Contractor(s) of foreign origin shall disclose the name and address of the agents/ representatives in India if any and the extent of authorization and authority given to commit the Principals. In case the agent/ representative be a foreign Company, it shall be confirmed whether it is existing Company and details of the same shall be furnished.
 - 2.1.2 The amount of commission/ remuneration included in the quoted price(s) for such agents/ representatives in India.
 - 2.1.3 Confirmation of the Tenderer that the commission/ remuneration, if any, payable to his agents/ representatives in India, may be paid by BHEL in Indian Rupees only.
- 2.2 Tenderers of Indian Nationality shall furnish the following details in their offers:
 - 2.2.1 The Bidder(s)/ Contractor(s) of Indian Nationality shall furnish the name and address of the foreign principals, if any, indicating their nationality as well as their status, i.e. whether manufacturer or agents of manufacturer holding the Letter of Authority of the Principal specifically authorizing the agent to make an offer in India in response to tender either directly or through the agents/ representatives.
 - 2.2.2 The amount of commission/ remuneration included in the price (s) quoted by the Tenderer for himself.
 - 2.2.3 Confirmation of the foreign principals of the Tenderer that the commission/ remuneration, if any, reserved for the Tenderer in the quoted price(s), may be paid by BHEL in India in equivalent Indian Rupees on satisfactory completion of the Project or supplies of Stores and Spares in case of operation items.
- 2.3 In either case, in the event of contract materializing, the terms of payment will provide for payment of the commission/ remuneration, if any payable to the agents/ representatives in India in Indian Rupees on expiry of 90 days after the discharge of the obligations under the contract.
- 2.4 Failure to furnish correct and detailed information as called for in paragraph 2.0 above will render the concerned tender liable to rejection or in the event of a contract materializing, the same liable to termination by BHEL. Besides this there would be a penalty of banning business dealings with BHEL or damage or payment of a named sum.

---X---

Annexure-B

This format is applicable only to Indian Suppliers/ Agents supplying indigenous portion of Foreign Purchases.

* In all other cases, extant guidelines of SEARP, 2010 are to be followed.

SEARP (SRF) Clause No	Detail
	Name & address of the firm
1.0	Products/ Systems / Services being considered for
2.0	General Information
2.2	Name of Chief Executive
2.3	Details of authorized signatory
3.0	Ownership Information
3.1	Type of firm
3.2	Nature of Business <ul style="list-style-type: none"> • Attach authorization letter and agency agreement from Principal (from whom capital equipment is procured) • Attach copy of declaration from Foreign Principal for total guarantee/ warranty of indigenous supplies
3.3	Year of establishment
3.4	Year of commencement of business
4.0	Registration particulars
4.1	Permanent Account No.
4.2 / 4.3	Sales Tax / TIN no
4.6	Service tax no. (in case of E&C)
5.0	Organisational strength
6.0	Other particulars
6.1	If the company is already registered with other units
6.2	Directors/ Partners, if related to any BHEL Employee
6.9	If any Ex BHEL Personnel employed by the Company
6.12	Details of pending legal issues with BHEL
6.13	Bank Account information
9.0	Financial information
9.6	Sales/ Turnover details of last 3 years (or from the date of incorporation whichever is less)

---X---