



ISO 9001:2008  
&14001:2004  
MAHARATNA  
COMPANY

37

**MATERIAL MANAGEMENT (PURCHASE)**  
**CENTRAL FOUNDRY FORGE PLANT, BHEL HARDWAR**  
RANIPUR, HARIDWAR (INDIA) – 249403  
Phone No. +91-1334-281277/284684, FAX No. 225892  
**e-mail : [ranjank@bhelhwr.co.in](mailto:ranjank@bhelhwr.co.in); [kraj@bhelhwr.co.in](mailto:kraj@bhelhwr.co.in);**  
**[amitkg@bhelhwr.co.in](mailto:amitkg@bhelhwr.co.in)**

**Sub:** Tender Enquiry No: 4424P/930/5/0643V1 due on 23.03.2016 at 2.00 PM.

Dear Sir,

We are pleased to invite offer as per enclosed specifications with terms and conditions in sealed covers for the under mentioned items.

SI No	Tender No	Description of Material	Qty	Date & Time of Opening
01	4424P/930/5/0643V11	Ingot Mould Dia 2160 mm	1 No.	23.03.16 at 2.00 PM

**KINDLY READ TERMS AND CONDITIONS. OFFER NOT IN ACCORDANCE WITH THE INSTRUCTIONS IS LIABLE TO BE DISQUALIFIED OR IGNORED.**

Please visit [www.bhel.com](http://www.bhel.com) or [www.bhelhwr.co.in](http://www.bhelhwr.co.in) for more details and tender documents.

Unregistered vendors should download Vendor Registration Form and submit same duly filled along with offer.

Thanking You,

Yours Faithfully,  
For & On behalf of CFFP, BHEL, Hardwar

(Amit Kumar Gupta)  
Dy. Manager (Purchase)

**Note:** Corrigendum if any shall not be published, kindly refers websites for any changes.

निविदा सूचना सं. ENQUIRY NO.★	<b>4424 P/ 930/5/0643V1</b>	दिनांक Date	<b>25-02-2016</b>
-------------------------------	-----------------------------	-------------	-------------------

कृपया निम्नलिखित के लिए निविदा दें। PLEASE QUOTE FOR THE FOLLOWING :

M/S. :: **DUEDATE 23-03-2016**  
:  
:  
:  
**Vendor Code 09285**  
**INDIA**

SL	MATERIAL CODE ITEM DESCRIPTION	QUANTITY	UNIT	LOTNO	LOT DELIVERY QTY SCHEDULE
1	FF1978000340 2160 MM DIA. INGOT MOULD (16 S IDED) SPEC: FF05073 REV 00 REV: ?? SIZE: SMS/INGOT MOULD/2160/16S/R 01 DIM.: S	1	NO		

**\*\* IMPORTANT: This enquiry is 2 part tender. Techno-Commercial bid (Part-1) & Price Bids (Part-2) should be submitted in separate envelopes. These two envelopes should be submitted in a common sealed envelope. Techno-Commercial Bid shall contain detailed Technical Specification, Drawings Technical documents, Catalogues, taxes & duties, payment terms, delivery period, Validity of offer, Replica of Price Bid (Copy of price bid without price part) etc. The confirmation to the special terms & conditions must be submitted alongwith Techno-Commercial bid.**

**Standard Instructions:**

TEST CERTIFICATE REQUIRED.  
GUARANTEE CERTIFICATE REQUIRED.  
BASIC RATES, TAXES DUTIES SEPERATELY  
CENVATABLE DUPLICATE COPY OF INVOICE.  
INSP AFTER RECPT AT CFPP.

**Special Instructions:**

SPECIFICATION ARE ENCLOSED.  
DRAWINGS ARE ENCLOSED.

**General Instructions:**

1. Please submit authorization letter (format enclosed) for facilitating e-payment/electronic transfer of funds
2. 100% payment within 30 days after receipt & acceptance of material at CFPP BHEL, Hardwar through e-payment.
3. CFPP/BHEL RESERVES THE RIGHT TO PRE-INSPECT THE MATERIAL AT VENDOR'S WORKS / GODOWN/ PREMISES BEFORE DESPATCH.
4. ORIGINAL MANUFACTURER'S TEST CERTIFICATE IS REQUIRED ALONG WITH DESPATCH DOCUMENTS. IN CASE SUPPLIES ARE FROM TRADERS, IT SHALL BE THE RESPONSIBILITY OF THE TRADER TO PROVIDE ORIGINAL MANUFACTURER'S TEST CERTIFICATE WITH LINKAGE TO TRADER'S INVOICE STATING BATCH NO.

Page No 1

★ महत्वपूर्ण : कृपया कोटेशन देने से पूर्व पीछे दिए गये अनुदेशों को ध्यानपूर्वक पढ़िये।

**IMPORTANT : PLEASE READ CAREFULLY THE INSTRUCTIONS GIVEN ON REVERSE BEFORE QUOTING**



AA-17001

निविदा सूचना  
**TENDER ENQUIRY**

भारत हैवी इलैक्ट्रिकल्स लिमिटेड  
**Bharat Heavy Electricals Ltd**  
सेन्ट्रल फाउन्ड्री फोर्ज प्लांट- हरिद्वार - २४६४०३ (भारत)  
**Central Foundry Forge Plant, Haridwar-249403 (INDIA)**

Phone : (0091) 01334- 281639,281385,285336 Fax : 01334 225892 / 226458

TIN NO. 05001763485  
C S T NO. HR-5018287 Dt. 16-03-1995

निविदा सूचना सं. ENQUIRY NO.*	<b>4424 P/ 930/5/0643V1</b>	दिनांक Date	<b>25-02-2016</b>
-------------------------------	-----------------------------	-------------	-------------------

कृपया निम्नलिखित के लिए निविदा दें। PLEASE QUOTE FOR THE FOLLOWING :

MATERIAL CODE ITEM DESCRIPTION	QUANTITY	UNIT	LOTNO
-----------------------------------	----------	------	-------

5. CFFP/BHEL Reserves the right to procure from more than one vendor.
6. Please quote prices in figures & words both. In case the prices quoted in words and figures are different, the values indicated in words will be considered for evaluation & establishing L1 status.
7. The Bidder along with its associate/ collaborators/ sub-contractors/ sub-vendors/consultants/ service providers shall strictly adhere to BHEL Fraud Prevention Policy displayed on BHEL website <http://www.bhel.com> and shall suspected immediately bring to the notice of BHEL Management about any fraud as soon as it comes to their notice.
- \* The offers of the bidders who are on the banned list as also the offers of the bidders, who engage the services of the banned firms, shall be rejected. The list of banned firms is available on web site [www.bhel.com](http://www.bhel.com)
- \*In case of rejection of material after receipt at CFFP, vendor / supplier is rejected material at their cost within 45 days from the date of rejection memo / note.
- \*If vendor / supplier fails to take back the rejected material from CFFP within 90 days from the date of rejection memo / note, CFFP has the right to dispose off the rejected material at the risk & cost of the vendor / supplier and no further claim for the rejected material will be entertained.
8. Documents submitted with the offer shall be signed and stamped in each page by authorized representative of the bidder.

*Amit Kumar Gupta*  
**AMIT KUMAR GUPTA**  
**DY. MANAGER**

★ महत्वपूर्ण : कृपया कोटेशन देने से पूर्व पीछे दिए गये अनुदेशों को ध्यानपूर्वक पढ़िये।

**IMPORTANT : PLEASE READ CAREFULLY THE INSTRUCTIONS GIVEN ON REVERSE BEFORE QUOTING**

**Tender Enquiry No.: 4424P/930/5/0643V1**

Evaluation shall be done on the basis of delivered cost i.e. "Total Cost to BHEL". Confirmation/comments on the conditions given below are mandatory. Please confirm the following or else your offer is liable to be rejected.

S.No.	Description	Vendor Confirmation /Comment I in case blank , it shall be deemed to be accepted by vendor)
A-	<b>Pre-Qualification Requirement (PQR)</b>	
01	- Vendor must have to be a Manufacturer /Manufacturer's agent of the product.	
02	- Vendor must have supplied at least one mould of min. 60 MT weight within last five years from date of tender opening.	
03	- In support of point (2) vendor has to provide copy of Purchase order / Purchase agreement/ Invoice. Note:- 1) Purchase Order will be placed on Original manufacture even if the offer is submitted by manufacturer's authorized agent. 2) Authorization letter (for Indian manufacturers)/Agency Agreement (for foreign manufacturers) has to be provided by the manufacturer's authorized agents	
B-	<b>COMMERCIAL TERMS &amp; CONDITIONS</b>	
01	<b>(Additional Techno-Commercial Requirement)</b> 1. The inspection of chemical composition, stress relieve cycle and dimension shall be carried out at supplier work from BVC, DNV,TUV (SUD),SGS,ALEC STEWARD,ALFRED H-KNIGHT. 2. Supplier shall bear the cost of inspection. 3. Guarantee for mould life needs to be provided by the Manufacturer (Minimum 4 heats)	
02	Test certificate required.	
03	Guarantee certificate is required.	
04	Material shall be supplied as per specification – <b>FF05073 Rev.00 for Ingot Mould</b> - (attached with enquiry) in all respect i.e. size, chemical composition, inspection, test certificate, packing & marking etc. without any deviation and the seller confirms agreement of all the clauses of the said specification. Material found in nonconformity to conditions of the above said specification shall be rejected.	
05	Third party inspection (before dispatch) from one of the following six inspection agencies i.e. <b>BVC, DNV, TUV (SUD),SGS,ALEC STEWARD,ALFRED H-KNIGHT</b> shall be arranged by seller at their cost. Third party inspection report should include test results as per requirement of tender enquiry specification. Scope of third party inspection is enclosed. Report of third party inspection shall be submitted along-with dispatch documents Acceptance of material shall be after final inspection at CFFP BHEL Haridwar as per tender enquiry / PO specification and shall	

	<p>be binding on seller. Material not found in conformance with applicable specification &amp; purchase order conditions will be rejected. In case material gets rejected during final inspection at CFFP the same shall be replaced by supplier immediately. All the charges (like To &amp; Fro freight, insurance etc.) for replacement shall be borne by supplier. Date of receipt of replacement material if accepted shall be considered as actual delivery date with respect to the PO delivery date for calculating penalty for Late Delivery.</p>	
06	<p>Final inspection of material will be done after receipt of material at CFFP. All the charges (like To and Fro freight, Insurance etc.) for replacement shall be borne by supplier. Date of receipt of replacement material if accepted shall be considered as actual delivery date with respect to the PO delivery date for calculating penalty for Late Delivery</p>	
07	<p><b>Delivery Term :-</b></p> <p>A. <u>For Indian Suppliers:</u> FOR, Destination (Door delivery basis). Destination will be C.Store, CFFP, BHEL, Haridwar.</p> <p>B. <u>For Foreign suppliers:</u> On CIF, Nhava Sheva , Mumbai</p> <p>Quoted rate should be inclusive of the charges like freight, service tax on freight, insurance, packing &amp; forwarding etc. <u>for the delivery term</u> given above or else proper loading shall be done.</p>	
08	<p><b>Delivery Schedule :-</b></p> <p>A. For Indian Suppliers: In one lot - within 60 days from P.O. date</p> <p>B. For Foreign suppliers: In one lot CIF, delivery-within 30 Days from L.C./ P.O. date, whichever is later.</p> <p>L.D. will be applicable as per above mentioned delivery Schedule. Vendor is requested to quote earliest possible delivery schedule.</p>	
09	<p><b><u>Conditions for opening of Price :- Conditions for opening of Price :-</u></b></p> <ol style="list-style-type: none"> <li><i>BHEL reserves the right to go for Reverse Auction (RA) instead of opening the sealed envelope price bid, submitted by the bidder. This will be decided after techno-commercial evaluation. All bidders to give their acceptance for participation in RA. Non-acceptance to participate in RA may result in non-consideration of their bids, in case BHEL decides to go for RA.</i></li> <li><i>In case BHEL decides to go for Reverse Auction, Only those bidders who have given their</i></li> </ol>	

	<p>acceptance to participate in RA will be allowed to participate in the Reverse Auction. Those bidders who have given their acceptance to participate in Reverse Auction will have to necessarily submit „online sealed bid“ in the Reverse Auction. Non-submission of „online sealed bid“ by the bidder will be considered as tampering of the tender process and will invite action by BHEL as per extant guidelines in vogue.</p> <p>3. In case BHEL decides to go for Reverse Auction, the H1 bidder (whose quote is highest in online sealed bid) may not be allowed to participate in further RA process.</p>	
10	<p>Payment Terms: <b>For Indian suppliers</b> – 100% within 30 days after receipt &amp; acceptance of material at CFFP / BHEL, Haridwar through e-payment. In case vendor does not agree, proper loading shall be done Loading will be @ Base rate of SBI (as applicable on the dated of bid opening, Techno-commercial bid opening in case of two part bids) + 6%, shall be considered for loading for the period of relaxation sought by bidders.</p> <p><b>For foreign suppliers:</b> Payment through USANCE LC on 70th day of bill of lading date. All bank charges shall be to vendor's account. In case vendor does not agree, proper loading shall be done. Also third party pre-despatch inspection shall have to be arranged by supplier from any of the six inspection agencies namely <b>BVC, DNV,TUV (SUD),SGS,ALEC STEWARD,ALFRED H-KNIGHT</b> at their cost.</p> <p>Loading will be @ Base rate of SBI (as applicable on the dated of bid opening, Techno-commercial bid opening in case of two part bids) + 6%, shall be considered for loading for the period of relaxation sought by bidders.</p>	
11	Validity of offers : minimum 120 days from tender opening date	
12	Evaluation of price bids will be done on the basis of total delivered cost at CFFP i.e. Landed cost net of Cenvat at CFFP.	
13	BHEL may place order for part quantity. Quoted rate not to be linked with order quantity.	
14	Rates shall be Firm till execution of purchase order.	
15	Material will be supplied as per delivery schedule required in tender enquiry / PO (FOR destination basis). Any request for extension in delivery schedule of Purchase Order / waiver of LD is liable to be ignored.	
16	<p>Normal clauses for imposing Penalty, Liquidated Damages for Late Delivery, Risk purchases, Cancellation, Arbitration in case of delay in effecting supply and or other defaults as per following conditions will be applicable:</p> <p>a. Penalty for Late Delivery: The delivery of the goods shall be made strictly as per time limit specified in delivery schedule, failure to supply within this period will make the seller liable to a penalty of 1/2 (half) percent of the price of the goods in arrears per</p>	

	<p>week subject to a maximum of 10% on the basic rate (total PO value). Any correspondence regarding waiver of LD shall not be entertained. In case supplier does not agree for LD clause, BHEL will load maximum penalty under LD clause, to the extent the same is not agreed by the vendor, for the purpose of comparative statement. Where deliveries quoted are not suiting, BHEL may ignore the offer.</p> <p>b. Risk Purchase: In case of delays in supplies / defective supplies or non-fulfilment of any other terms and conditions given in the Purchase Order by the seller, the Buyer reserves the right to cancel the purchase order in full or part thereof, and may also make the purchase of such material from alternative source <u>at the risk and cost of the seller.</u></p>	
17	For new vendors who are not registered with CFFP BHEL Haridwar, please submit duly filled up "Supplier Registration Form (SRF)" (available at <a href="http://www.bhel.com">www.bhel.com</a> ) /statutory documents as per SRF along-with techno-commercial bid of offer.	
18	BHEL will prefer to deal directly with foreign vendor/ original manufacturer. In case, vendor engages any Indian agent or take service of any Indian agent, copy of agent agreement required along with offer in line with Annexure-IV attached.	
19	In the event of any dispute arising out of contractual obligation, the order being finalized at Haridwar, India will be subject to Indian Laws and falls under jurisdiction of the court of Law at Haridwar, India.	
20	<p>Indian Vendors shall quote their price only in INR. Foreign vendors shall quote their price only in USD, EURO, UK POUND STERLING and JAPANESE YEN.</p> <p>For evaluation of price bids, exchange rate (TT selling rate of SBI) as on scheduled date of tender opening (Part-1 bid in case of two part bid) shall be considered.</p>	
21	Vendor shall quote price both in words & figures. If there is any difference between price quoted in words & figures, price quoted in words shall prevail and binding.	
22	Please provide contact person name, telephone nos. , fax no. & email id.	
23	<p>A. In case of any difference in conditions quoted above &amp; elsewhere in the offer, terms quoted above shall be treated as final and binding on vendor.</p> <p>B. Non acceptance of any of the above conditions may result in rejection of your offer.</p> <p>C. Terms &amp; Conditions not specified above will be as per Annexure-B No GTCRM NO. 01 Rev.05 Date:</p>	

	25.10.12 enclosed. D. In case of blank / no comments in provided remark column, it shall be deemed to have been accepted by vendor.	30
24	<b>Kindly mention tax structure :</b> (a) Excise Duty in % (b) CST in % (c) VAT in % without concessional form (d) Freight amount in Rs. (e ) Packing & Forwarding %	

Date:

Signature with Name of authorized signatory)  
Seal of the Company

GENERAL TERMS AND CONDITIONS OF TENDER ENQUIRY  
ANNEXURE-B

01 Submit the tender in two parts i.e.

**Part-I Techno-Commercial Bid**

**Part-II Price Bid**

Techo - Commercial (part one) Price Bid (part two) should be put in separate sealed envelopes. Both envelopes should be super scribed with **Tender Number, Date of opening & Technical / Commercial Bid and Price Bid** respectively along with name of firm.

Both the envelopes i.e. containing Techno-Commercial Bid and Price Bid should again be kept in one envelope super scribed again with Tender No. and Date of opening and the name of firm submitting the tender and send it to **AGM (MM), Purchase Department, CFFP/BHEL, Hardwar, Ranipur, Hardwar 249403, Uttarakhand, India before due date / tender opening date & time**. Normally tender opening time is 2.00 PM on due date or as mentioned in enquiry.

**Responsibility for submission of tender in time solely lies with vendor. Late offers received after specified time / Date shall not be considered.**

1. Part-I Envelopes super scribed with **Techno-Commercial Bid** must contain all information especially-
  - (a) Specification of the material offered should be strictly as per CFFP/BHEL specifications of enquired material in tender documents **Deviations if any must be indicated clearly in the offer. Rates to be quoted on For Destination Basis.**
  - (b) All commercial terms i.e. packing, forwarding Custom duty, Additional Duty, ST/STT/VAT/CST, Excise Duty/CVD, Bank charges, payment terms & insurance etc as applicable (**except price**) should be clearly mentioned in Techno-Commercial bid. Also mention present rate of applicable taxes & duties even if inclusive in rates along with the concessional forms required if any.
  - (c) Confirm to submit all required commercial documents (tax invoice centvatable duplicate copy of invoice, packing list, transit sale agreement etc.) & technical documents (TC/GC/QP etc).
  - (d) Registration Numbers of SSI, Central Excise, Sales tax, Income Tax, DGS & D.ECC etc.
  - (e) **Un-priced copy of Price Bid.**

Part-II Envelopes super scribed with Price Bid should contain priced copy of Price Bid. The price should be mentioned both in figures and words.

2. Authorized Signatory should authenticate all tender documents.
3. **Techno-commercial bid (Part-I)** will be opened on the due date at 2.00 PM in the presence of participating vendors or authorized representatives, who may wish to be present. Representative deputed to witness tender opening must produce an authority letter from the signatory of offer. After evaluation of technical bids & finalization of technical, commercial terms & conditions, price bid of only successful vendors will be opened. Priced bid opening date shall be intimated separately.
4. The material offered must conform to the required BHEL specifications and drawings as well as instructions and details made available.
5. For new vendors, Vendor Registration from duly filled must be submitted along with the offer which can be downloaded from our web site [www.bhel.com](http://www.bhel.com) or [www.bhelhwr.co.in](http://www.bhelhwr.co.in).
6. Original manufacturer's Test Certificate is required along with dispatch documents. In case supplies are from traders, it shall be the responsibility of the trader to provide original manufacture's test certificate with linkage to traders invoice stating batch no.
7. **Validity** of offers should be minimum 90 working days from the date of tender (Techno-Commercial Bid) opening.

- 28
8. **Delivery** in the promised period is the essence of contract. Confirm to supply according to delivery schedule mentioned.
  9. **Payment terms:**  
For indigenous suppliers: 100% within 30 days after receipt & acceptance of material at CFFP / BHEL, Haridwar through e-payment.  
For foreign suppliers: Payment through USANCE LC on 70<sup>th</sup> day of bill of lading date. All bank charges shall be to vendor's account.  
  
\* In case vendor does not agree, proper loading shall be done. Also in that case, third party inspection shall have to be arranged by supplier from any of the five inspection agencies namely: LRS/ BVQI/ DNV/ TUV/ Alfred H Knight at their cost.
  10. CFFP/BHEL, Haridwar reserves the right to accept or reject any or all tenders without assigning any reason thereof.
  11. Tenders not submitted in the prescribed manner are likely to be ignored / rejected.
  12. Agent/Agency Commissioning: Payment of any kind at any stage will not be made to agent on account of agent commission or otherwise by CFFP/BHEL, Haridwar.
  13. CFFP/BHEL, Haridwar may opt for E-auction/Reverse auction for obtaining best prices for part or full tendered quantity. BHEL also reserve the right to negotiate price with L1 vendor after reverse auction.
  14. Please do intimate the personal contact details like Name, Mobile Number, Email-id etc of authorized executive for correspondence.
  15. **Penalty:** Orders placed against this enquiry will be subject to normal clauses for imposing penalty. Liquidated Damages, Risk purchases, cancellation, arbitration as per terms and conditions of Tender Enquiry and Purchase orders in case of delay in effecting supply and/ or other defaults.  
**Liquidated damage:** The delivery of the goods shall be made strictly as per time limit specified in delivery schedule, failure to supply within this period will make the supplier liable to an conditional penalty of 1/2 (half) percent of the price of the goods in arrears per week subject to a maximum of 10%.
  16. **Inspection:** Final inspection of material shall be done after receipt of material at CFFP/BHEL, Haridwar. Acceptance of material shall be after final inspection and shall be binding. However, CFFP reserves the right to pre Inspect the material at supplier works. In case material is found defective during warranty period, the same will be returned for repair and/ or replacement. For this vendor has to bear all the charges such as Freight, to and fro insurance etc. Bank Guarantee for the equal amount to the cost of the item is to be furnished by vendor. In case the repair is done at CFFP/BHEL the amount on actual shall have to be reimbursed by the Vendor and or adjusted on actual from their bill.
  17. **Currency of Payment:** Mention the currency in which payment has to be made. For evaluation of price bids, exchange rate (TT selling rate of SBI) as on scheduled date of tender opening (Part-1 bid in case of two part bid) shall be considered.
  18. Traders should submit authorization letter from their principal alongwith offer.
  19. **Disputes:** In event of any dispute arising out of contractual obligation, the order being finalized at Haridwar, India will be subject to Indian Laws and falls under jurisdiction of the court of Law at Haridwar, India. The overseas supplier hereafter referred to as "Vendor" shall therefore abide by the verdict of Court of Law at Haridwar, India.  
OR  
All disputes arising out of or in connection with the present contract, if any shall be finally settled under the rules of arbitration of International chamber of commerce by one or more arbitrator appointed in accordance with the said Rules in India.
  20. BHEL reserves the right to place P.O. for part / full qty and on one or more than one sources.
  21. Any Term & condition of the specific tender (if specified in tender & contradicts with above term) will supersede the above general terms & conditions.

**Terms and conditions regarding Indian agent of foreign suppliers:**

01. BHEL shall deal directly with foreign vendors, wherever required, for procurement of goods. However, if the foreign principal desires to avail of the services of an Indian agent, then the foreign principal should ensure compliance to regulatory guidelines- which require mandatory submission of an Agency agreement.
02. It shall be incumbent on the Indian agent and the foreign principal to adhere to the relevant guidelines of Government of India, issued from time to time.
03. The agency agreement should specify the precise relationship between the foreign OEM/Foreign principal and their Indian agent and their mutual interest in the business. All services to be rendered by agent/associate, whether of general nature or in relation to the particular contract, must be clearly stated by the foreign supplier / Indian agent. Any payment, which the agent or associate receives in India or aboard from the OEM, whether as commission or as a general retainer fee should be brought on record in the agreement and be made explicit in order to ensure compliance to laws of the country.
04. Any agency commission to be paid by BHEL to the Indian agent shall be in Indian currency only.
05. Tax deduction at source is applicable to the agency commission paid to the Indian agent as per the prevailing rules.
06. In the absence of any agency agreement, BHEL shall not deal with any Indian agent (authorized representatives/ associate/consultant, or by whatever name called) and shall deal directly with the foreign principal only for all correspondence and business purposes.
07. The "Guidelines for Indian Agents of Foreign Suppliers" enclosed at annexure- 'A' shall apply in all such cases.
08. The supply and execution of the Purchase Order (including indigenous suppliers/service) shall be in the scope of the OEM/ Foreign principal. The OEM/ Foreign principal should submit their offer inclusive of all indigenous suppliers/services and evaluation will be based on 'total cost to BHEL'. In case OEM/ foreign principal recommends placement of order(s) towards indigenous portion of supplies/services on Indian Supplier (s)/ agent on their behalf, the credentials/capacity/capability of the Indian Supplier (s)/ agent to make the supplies/Services shall be checked by BHEL as per the extant guidelines of Supplier Evaluation, Approval and Review Procedure (SEARP), before opening of price bids. In this regards, details may be checked as per Annexure- 'B' (copy enclosed). It will be the responsibility of the OEM/ Foreign Principal to get acquainted with the evaluation requirements of Indian supplier/agent as per SEARP available on [www.bhel.com](http://www.bhel.com).

The responsibility for successful execution of the contract (including indigenous supplies/services) lies with the OEM/ foreign principal. All bank guarantees to this effect shall be in the scope of the OEM/Foreign principal.

**Guidelines for Indian Agents of Foreign Suppliers**

- 1.0 There shall be compulsory registration of agents for all Global (Open) Tender and Limited Tender. An agent who is not registered with BHEL shall apply for registration in the registration form in line with SEARP.
- 1.1 Registered agents will file an authenticated Photostat copy duly attested by a Notary Public/Original certificate of the Principal confirming the agency agreement and giving the status being enjoyed by the agent and the commission/ remuneration/ salary/ retainership being paid by the principal to the agent before the placement of order by BHEL.
- 1.2 Wherever the Indian representatives have communicated on behalf of their principals and the foreign parties have stated that they are not paying any commission to the Indian agents, and the Indian representative is working on the basis of salary or as retainer, a written declaration to this effect should be submitted by the party (i.e. Principal) before finalizing the order.
- 2.0 Disclosure of particulars of agents/ representatives in India, if any.**
- 2.1 Tenderers of Foreign nationality shall furnish the following details in their offers:
- 2.1.1 The Bidder(s)/ Contractor(s) of foreign origin shall disclose the name and address of the agents/ representatives in India if any and the extent of authorization and authority given to commit the Principals. In case the agent/ representative be a foreign Company, it shall be confirmed whether it is existing Company and details of the same shall be furnished.
- 2.1.2 The amount of commission/ remuneration included in the quoted price(s) for such agents/ representatives in India.
- 2.1.3 Confirmation of the Tenderer that the commission/ remuneration, if any, payable to his agents/ representatives in India, may be paid by BHEL in Indian Rupees only.
- 2.2 Tenderers of Indian Nationality shall furnish the following details in their offers:
- 2.2.1 The Bidder(s)/ Contractor(s) of Indian Nationality shall furnish the name and address of the foreign principals, if any, indicating their nationality as well as their status, i.e. whether manufacturer or agents of manufacturer holding the Letter of Authority of the Principal specifically authorizing the agent to make an offer in India in response to tender either directly or through the agents/ representatives.
- 2.2.2 The amount of commission/ remuneration included in the price (s) quoted by the Tenderer for himself.
- 2.2.3 Confirmation of the foreign principals of the Tenderer that the commission/ remuneration, if any, reserved for the Tenderer in the quoted price(s), may be paid by BHEL in India in equivalent Indian Rupees on satisfactory completion of the Project or supplies of Stores and Spares in case of operation items.
- 2.3 In either case, in the event of contract materializing, the terms of payment will provide for payment of the commission/ remuneration, if any payable to the agents/ representatives in India in Indian Rupees on expiry of 90 days after the discharge of the obligations under the contract.
- 2.4 Failure to furnish correct and detailed information as called for in paragraph 2.0 above will render the concerned tender liable to rejection or in the event of a contract materializing, the same liable to termination by BHEL. Besides this there would be a penalty of banning business dealings with BHEL or damage or payment of a named sum.

---X---

25

## Annexure-B

This format is applicable only to Indian Suppliers/ Agents supplying indigenous portion of Foreign Purchases.

\* In all other cases, extant guidelines of SEARP, 2010 are to be followed.

SEARP (SRF) Clause No	Detail
	<b>Name &amp; address of the firm</b>
<b>1.0</b>	<b>Products/ Systems / Services being considered for</b>
<b>2.0</b>	<b>General Information</b>
2.2	Name of Chief Executive
2.3	Details of authorized signatory
<b>3.0</b>	<b>Ownership Information</b>
3.1	Type of firm
3.2	Nature of Business <ul style="list-style-type: none"> <li>• Attach <b>authorization letter</b> and <b>agency agreement</b> from Principal ( from whom capital equipment is procured)</li> <li>• Attach copy of declaration from Foreign Principal for <b>total guarantee/ warranty of indigenous supplies</b></li> </ul>
3.3	Year of establishment
3.4	Year of commencement of business
<b>4.0</b>	<b>Registration particulars</b>
4.1	Permanent Account No.
4.2 / 4.3	Sales Tax / TIN no
4.6	Service tax no. (in case of E&C)
<b>5.0</b>	<b>Organisational strength</b>
<b>6.0</b>	<b>Other particulars</b>
6.1	If the company is already registered with other units
6.2	Directors/ Partners, if related to any BHEL Employee
6.9	If any Ex BHEL Personnel employed by the Company
6.12	Details of pending legal issues with BHEL
6.13	Bank Account information
<b>9.0</b>	<b>Financial information</b>
9.6	Sales/ Turnover details of last 3 years (or from the date of incorporation whichever is less )

---x---

24

AUTHORISATION LETTER  
FOR E-PAYMENT/ELECTRONIC FUNDS TRANSFER (EFT/RTGS)  
PLEASE FILL UP THE FORM IN CAPITAL LETTERS ONLY

TYPE OF REQUEST (Tick One)  CREATE  CHANGE

BHEL Vendor/ Supplier Code   
Company's Name   
Address   
City   
Pincode   
State

Contact Person(S)   
Telephone NO.   
FAX. No.   
e-mail id

1. Bank Name   
2. Bank Address   
3. Bank Telephone No.   
4. Bank Account No.   
5. Account Type.   
6. Bank's Branch Code   
7. Bank's IFSC Code   
8. Bank Swift Code

9. Enclose blank cancelled cheque

DECLARATION

- 1. I as representative/Owner of the above named company, hereby authorize BHEL CFFP, Ranipur, Haridwar to electronically make payments to the designated bank account. I hereby certify that the particulars given above are true, complete and correct.
- (2) If the transsation is delayed or not effected at all for reasons of incomplete or incorrect information, I would not hold BHEL/transfereing Bank responsible.
- 3. This authority remains in full force untill BHEL, CFFP, Ranipur, Haridwar receives & acknowledge written notification requesting a change or cancellation.
- 4. I have read the contents of the covering letter and agree to discharge the responsibility expected of me as a participant under E-payment/EFT/RTGS.

Date:  
Authorized Signatory  
Designation

Company Seal

Verification By Bank

Please provide e-payment details verified by Bank along with cancelled cheque in the Format (above) to CFFP / BHEL Haridwar for enabling e-payments.



**CAST IRON ITEMS**

**1. SCOPE**

This specification governs the quality of cast iron Items of various sizes used for production of steel ingots in Steel Melting Shop.

**2. APPLICATION**

The material shall be used as tools & tackles for production of steel ingots.

**3. COMPLIANCE WITH NATIONAL STANDARDS**

This specification in general is based on Indian standard IS: 3005 Part II (1979) Reaffirmed 2005, First revision.

**4. CONDITION OF DELIVERY**

- The castings shall be produced from high carbon iron solidifying to provide a structure containing large flake graphite within a matrix consisting of free ferrite and coarse lamellar pearlite phase.
- Massive free-carbide phase and grain boundary free-carbide phase shall be absent from the matrix.
- The Cast Iron Items shall be produced in accordance with the details of the drawing referenced and designated on the purchase order.
- The internal mould profile shall be symmetrical.
- The internal surface of moulds shall have a continuous plane-of-taper along each face and along each corner. The internal faces and corners shall be smooth and free from significant porosity and non-metallic inclusions.
- External surfaces shall be free from significant defects and from protrusions/imperfections likely to impair safety conditions during use.
- Where machined, surfaces shall be free from significant porosity and non-metallic inclusions.
- Castings shall be defect free.

COPYRIGHT AND CONFIDENTIALITY  
 The information herein is the property of Bharat Heavy Electricals Limited. It is confidential and its disclosure or distribution in any form without the prior written consent of BHEL is prohibited.

REP	SOM NATH GHOSH	<i>[Signature]</i>	Worked by	MANOJ KUMAR SAHU	<i>[Signature]</i>
MPPC	ANIRAG K. SHWABA	<i>[Signature]</i>	Checked by	SUNIL K. MAR	<i>[Signature]</i>
CHAIRMAN PSC	V. K. AGARWAL	<i>on leave</i>	Supervised by	P. K. ROY	<i>[Signature]</i>
			APPROVED - <b>PLANT STANDARDS COMMITTEE</b>		
			PREPARED - SMS TECH	ISSUED - Steel Melting Shop	DATE 16/1/16

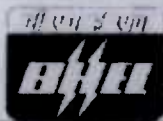

# PLANT PURCHASE SPECIFICATION

FF 05073 Rev 00

(CFEP - HARDWAR)

Page 2 of 3

## 5. CHEMICAL COMPOSTION

The material shall conform to the following chemical composition when it is analyzed in accordance with IS 228-1959 / any international standard/ validated instrumental methods.

ELEMENT	% MIN	%MAX
C	3.60	3.80
Si	1.50	1.80
Mn	0.50	0.70
S	0.06	0.08
P	-	0.05
Cr	-	0.04
Sn	-	0.005
Ni	-	0.20
CEV( Where CEV = C+ Si/4+P/2)	4.20	4.30

Where the iron used is produced as direct iron or "first fusion iron" from the blast furnace, the values of C and Si may be amended by agreement.

## 6. HARDNESS

The hardness of the Cast Iron Items of mass less than 15 tonnes shall not exceed 140 HB and for mass more than 15 tonnes it shall not exceed 130 HB.

## 7. FETTLING

Primary fettling of castings involve removal of stubs of riser-feeders and stubs of in-gates. The use of any type of burning/thermal technique to aid such fettling shall not be permitted.

The end faces of the mould castings shall be machined normal to the centerline of the casting as per drawing.

Secondary fettling of the casting is accepted in that some fettling of casting defects from the casting may be carried out without significantly impairing the service behaviour and performance of the casting. The use of any type of burning/thermal technique shall not be permitted.

The fettling operation shall:

- Maintain the drawing defined section profile.
- Maintain a continuous plane-of-taper along each face and along each corner internally for the length of the mould.
- Localized indentations in the internal mould surface from removal of casting defects are not acceptable.

COPYRIGHT AND CONFIDENTIAL  
The information in this document is the property of Bharat Heavy Electricals Limited. It is to be used only for the purpose for which it is provided by the company.

WORKED BY	M.K. Sahu		
CHECKED BY	Sunil Kumar		

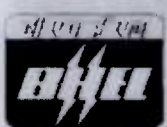

# PLANT PURCHASE SPECIFICATION

FF 05073 Rev 00

(CFFP - HARDWAR)

Page 3 of 3

## 8. HEAT TREATMENT

The Cast Iron Items shall be stress relieved by heating to a temperature of 700-750°C and soaking for 10-30 hours depending upon the thickness of the casting and by cooling slowly at the rate of 40 °C /hr in the furnace till the temperature of 250 °C is attained.

### Soaking Hours:

Casting Thickness(mm)	Casting Wt(Tonnes)	Min.Soaking Hours
>300 mm	50-100	12
200- 300 mm	25-50	8
150-200	15-25	6
100-150	3-15	4

\*For every increase in thickness of 25 mm, Soaking hours to be increased by 1 Hour.

## 9. INSPECTION :

- CFFP reserves the right to witness third party inspection for the testing of the material at supplier's works and therefore the supplier shall notify his readiness for inspection of casting in advance.
- Scope of third party inspection:
  - Witnessing the Chemical analysis, Heat Treatment Cycle, Mechanical Testing, Microstructure analysis for all castings.
  - Inside and outside Magnetic Particles Testing for castings of weight more than 25 Tonnes. Visual inspection for castings of weight less than 25 Tonnes.
- CFFP may, at its discretion, test the casting after receipt and acceptance of the casting will be based on the CFFP'S test results.

## 10. IDENTIFICATION

Castings shall be identified with the maker's insignia, the casting type, and serial number. For moulds, the identity shall be cast on each trunnion side of the mould in minimum 100 mm letters readable in the wide-end-up orientation.

## 11. TEST CERTIFICATES

Certification shall be supplied with each casting showing compliance with the terms of this specification relating to material chemistry, heat treatment cycle, microstructure analysis, hardness and the dimensional condition as per clause-4.

COPYRIGHT AND CONFIDENTIAL  
The information in this document is the property of Bharat Heavy Electricals Limited. It must not be used, directly or indirectly, in any way detrimental to the interest of the company.

WORKED BY	M.K. Sahu		
CHECKED BY	Sunil Kumar		

FIRST ANGLE PROJECTION ( ALL DIMENSIONS ARE IN M.M. )

SMS/INGOT MOULD/2160/188

DRAWING NUMBER

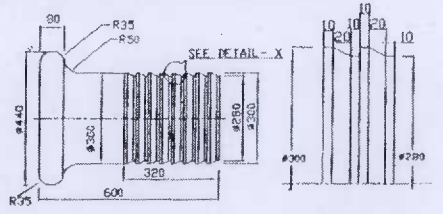
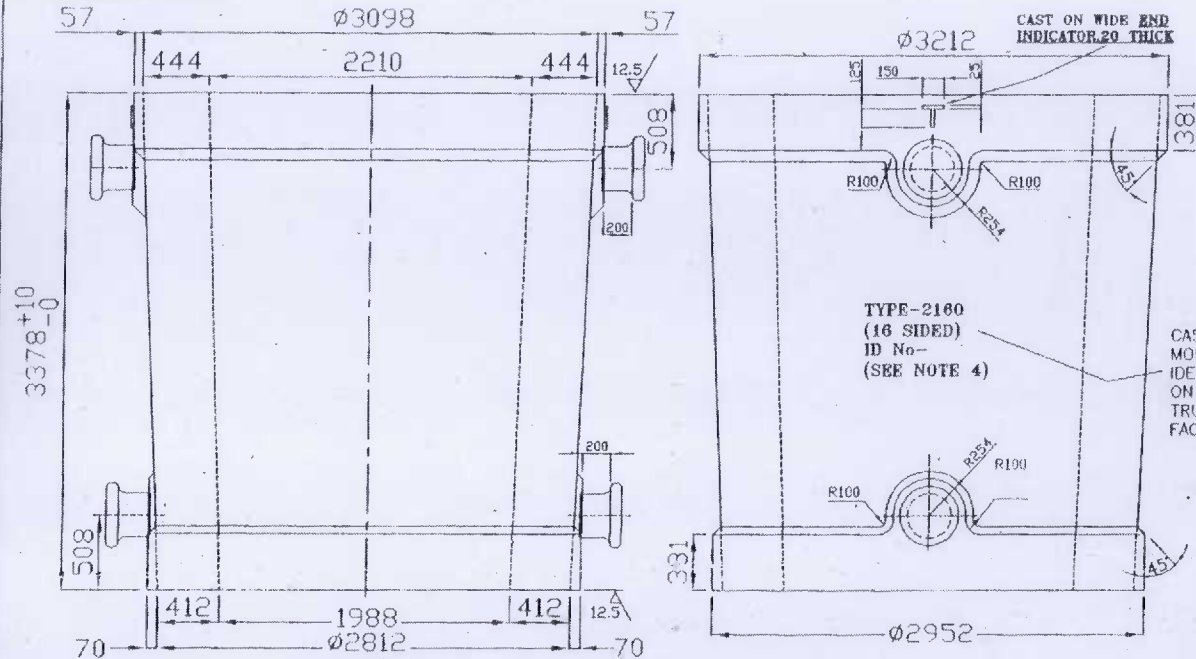

TRUNNION DETAIL-X

NOTE:

- 1.) DIMENSIONAL TOLERANCE =  $\pm 2$ MM
- 2.) COMPOSITION OF C.I. INGOT MOULD  
 TOTAL C 3.7-4.2%  
 SILICON 0.8-1.4%  
 MANGANESE 0.55-0.9%  
 SULPHUR  $\leq 0.05\%$   
 PHOSPHOROUS  $\leq 0.03\%$
- 3.) HEAT TREATMENT:  
 STRESS RELIEVING BY HEATING UP TO 700-750°C AND SOAKING FOR MIN. 20 HOURS AND COOLING SLOWLY BY 40°C PER HOUR TILL TEMP. OF 250°C IS ATTAINED
- 4.) ID No SHALL BE SUPPLIER'S UNIQUE IDENTIFICATION NO.

- TRUNNION
1. MATERIAL : C40
  2. IT SHOULD BE FORGED IN SINGLE PIECE AND MACHINED TO SIZE.
  3. ROUGH MACHINED TRUNNION SHOULD BE ULTRASONICALLY TESTED AS PER BHEL CORPORATE STANDARD NO. AA-0850118 Rev01.
  4. DIMENSIONAL TOLERANCE : +1/-1

CIRCULAR EXTERNAL PROFILE

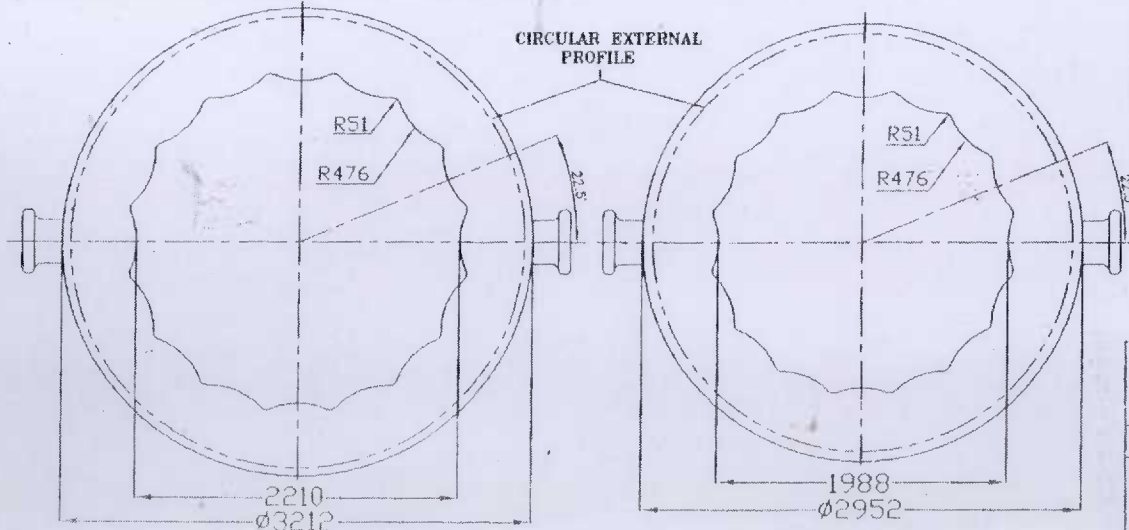

WIDE END PLAN

NARROW END PLAN

<b>BHARAT HEAVY ELECTRICALS. LTD.</b> CENTRAL FOUNDRY FORGE PLANT RANIPUR HARDWAR				
WEIGHT 79000 Kgs	NAME	SIGN	DATE	
TITLE: <b>2160 mm DIA INGOT MOULD</b> (16 SIDED)	DRN	SUNIL KUMAR	24/06/18	
	CKD	P. K. ROY	24/06/18	
	APD	V.K. RAIZADA	24/06/18	
DEPARTMENT SMS	DRG NO.	SMS/INGOT MOULD/2160/188		
REF. NO-SFS0022	Rev:1.0	TRUNNION PART CHANGED		