

REV.	DATE	ALTERED	E.M.A	REV.	DATE	ALTERED	REV.	DATE	ALTERED
04	29-07-02	CHECKED	N.D.S			CHECKED			CHECKED
		APPROVED	RAMANNA			APPROVED			APPROVED

DRG.REDRAWN.

SUPPIERS NAME TO BE CLEARLY STAMPED ON THIS FACE 5MM DEEP THE IDENTIFICATION SHOULD BE 3MM DEEP IMPRESSION OR 3MM LETTERS WELL IN THE DEPRESSION.

SOFT GERY IRON

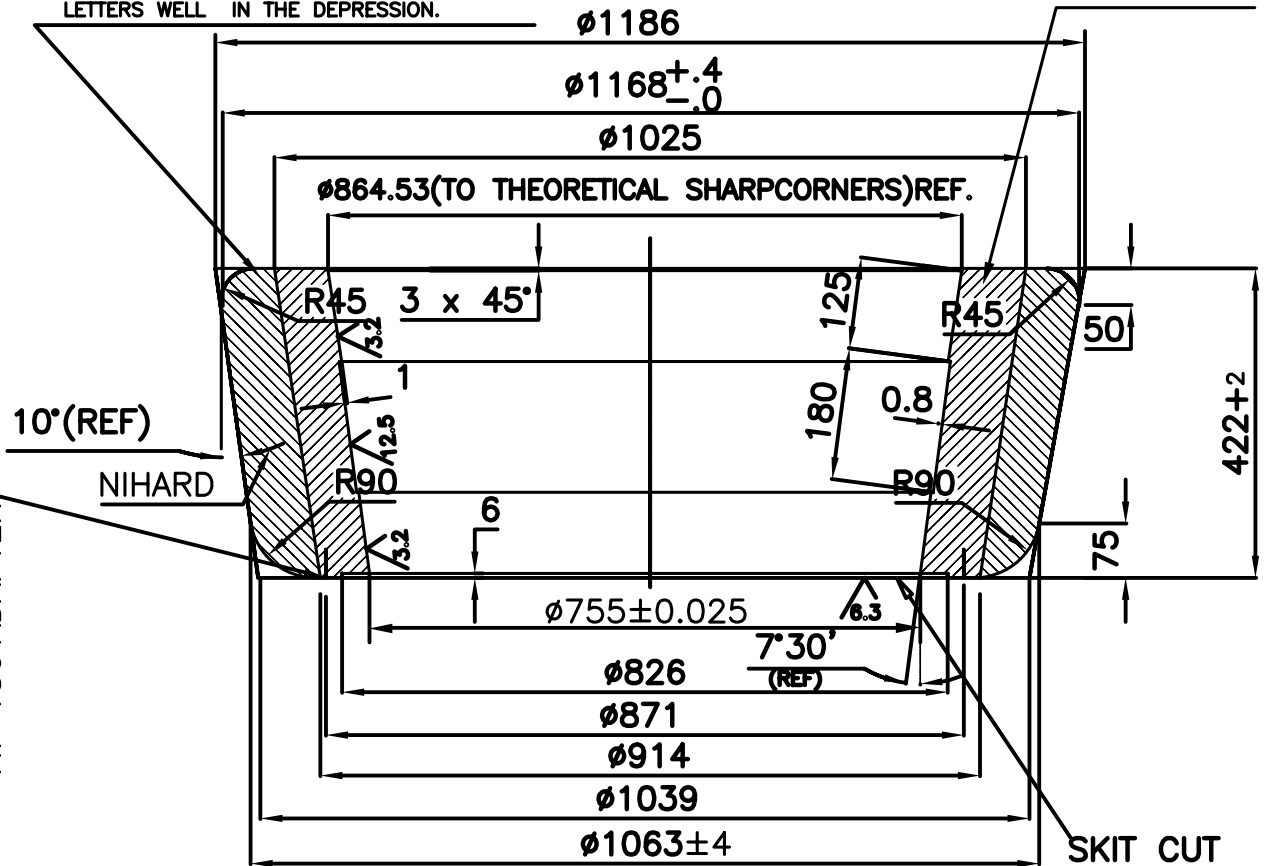

NOTES:

1. TOLERANCE FOR UNTOLERENCED DIM FOR CASTING AA0230402 - CLASS3
2. FOR MACHINED DIMENSION AA 0230208 MEDIUM CLASS
3. TAPER MUST BE CHECKED WITH PLATE GUAGE MINIMUM 80MINIMUM 80% OF ITS CONTACT AREA. CHECKED AT 3 PLACES 120°APART.
4. FOR NIHARD, MINIMUM HARDNESS IS 550 BHN
5. MANUFACTURE AS PER CUSTOMERS / BHEL APPROVED QP.
6. COAT THE MACHINED BORE SURFACE WITH BLUE LAQUER AND REMOVE THE BLUE LAQUER BEFORE ASSY

NOTE:-

NIHARD TREAD THICKNESS TO BE $+0.0$
 -4.0

THE INFORMATION ON THIS DOCUMENT IS THE PROPERTY OF BHARAT HEAVY ELECTRICALS LIMITED. IT MUST NOT BE USED DIRECTLY OR INDIRECTLY IN ANY WAY DETRIMENTAL TO THE INTEREST OF THE COMPANY.

2 HOLES M20 X 38 DEEP AT 180°ADAPTER

COMPUTER NO.	46190204	CASTING	PATTERN M-67-430	BA9616801015	1380.00
REF. DRG. NO.		DESCRIPTION & DRG.NO.	VAR NO.	MATL. CODE	NET.WT. GROSS WT
				MATL. SPECN.	QTY.
TYPE OF PRODUCT OR NAME OF CUSTOMER/PROJECT					

INVENTORY NO.	REF. TO HY0230: UNSPECIFIED TOL	DEPT. BMD	CODE 446	SCALE 1:10	WEIGHT(K.G.) 1380.00	REF.TO ASSY.DRG.	ITEM NO.	NO.OF ITEM
						DRN. E.M.ASHOK	29.07.02	NO.OF VAR.
						CKD. N.D.S		
						APPD. RAMANNA		
TITLE						DRAWING NO.	REV.	
GRINDING ROLL-HP 803 (46")						4-61-080-90204	04	
						SHT.NO. 1	NO.OF SHT. 1	

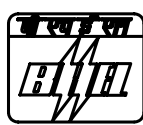

BHARAT HEAVY ELECTRICALS LTD. HYDERABAD

