

	<b>BHARAT HEAVY ELECTRICALS LIMITED</b> [A Government of India Undertaking] Ramachandrapuram, Hyderabad, 502032, A.P. India Phone 040-23184526, 23182322 FAX:040-23021910, 1954	<b>भारत हेवी इलेक्ट्रिकल्स लिमिटेड</b> (भारत सरकार का उपक्रम) रामचन्द्रपुरम, हैदराबाद, 502032 आंध्र प्रदेश, भारत	RFQ NO :	<b>PURCHASE DEPARTMENT</b> <b>ENQUIRY</b> <b>क्रय विभाग</b> जांच (ई मेल : tenderbox@bhelhyd.co.in)	SHEET:1 OF :1
	<b>PURCHASE DEPARTMENT</b>				

HY17001 C REV.NO.0	Phone 091-40-23184526 091-40-23182322	FAX : 091-40-23021910 091-40-23021954	E Mail: tenderbox@bhelhyd.co.in	<b>PURCHASE DEPARTMENT</b>	
Enq/Collective Number :M1A1N05162		Enq.Date : 13.06.2014	No.Of Items :1	DUE DATE OF QUOTATION : 24.06.2014	

**Office Copy**

Please submit your lowest quotation in sealed cover superscribed with Enquiry No./Collective No.(RFQ No ..... ) and due date subject to our terms and conditions attached ,for the materials mentioned below.Your offer has to reach us onor before due date by 11.00 Hours (IST) and will be opened at 14.00 Hours.(IST).If our Enquiry No./Collective No.(RFQ No ..... ) and tender due date are not super scribed on the tender cover , your offer shall be summarily rejected.Whosoever desires to send offers on their own risk (complete in all respects) via e-mail have to send offers to the common e-mail address : tenderbox@bhelhyd.co.in . Incomplete offers and late offers will not be considered.

SL NO	Purchase Req.no	item no	Material Code	Drg no - Ver , Rev & Spec - Ver , Rev	Description	Unit	Qty	Delivery Date	Schedule Qty
1	1600005162	10	HY8460043010	,	HEATING ELEMENT 3RS0888 1.2MM 3KM	EA	200.000	30.07.2014	200.000

**Special Remarks**

1.GENERAL CONDITION OF CONTRACT (GCC) HY:MM:GCC REV OO IS APPLCABLE 2.INSTRUCTION TO BIDDER (ITB) HY: MM: ITB REV OO ATTACHED ALONG WITH THISENUIRY SHALL BE DULY FILLED IN AND SUBMITTED TO CONSIDER YOUR OFFER 3. TWO PART BID SYSTEM SHALL BE FOLLOWED

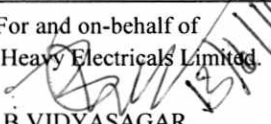
TEST CERTIFICATE REQD: Y GUARANTEE REQ : Y SAMPLE REQD : N BID TYPE : TWO PART	For and on-behalf of Bharat Heavy Electricals Limited  B.VIDYASAGAR PURCHASEOFFICER/CMM
---	--

DRG. NO.

FIRST ANGLE P SECTION

(ALL DIMENSIONS ARE IN mm)

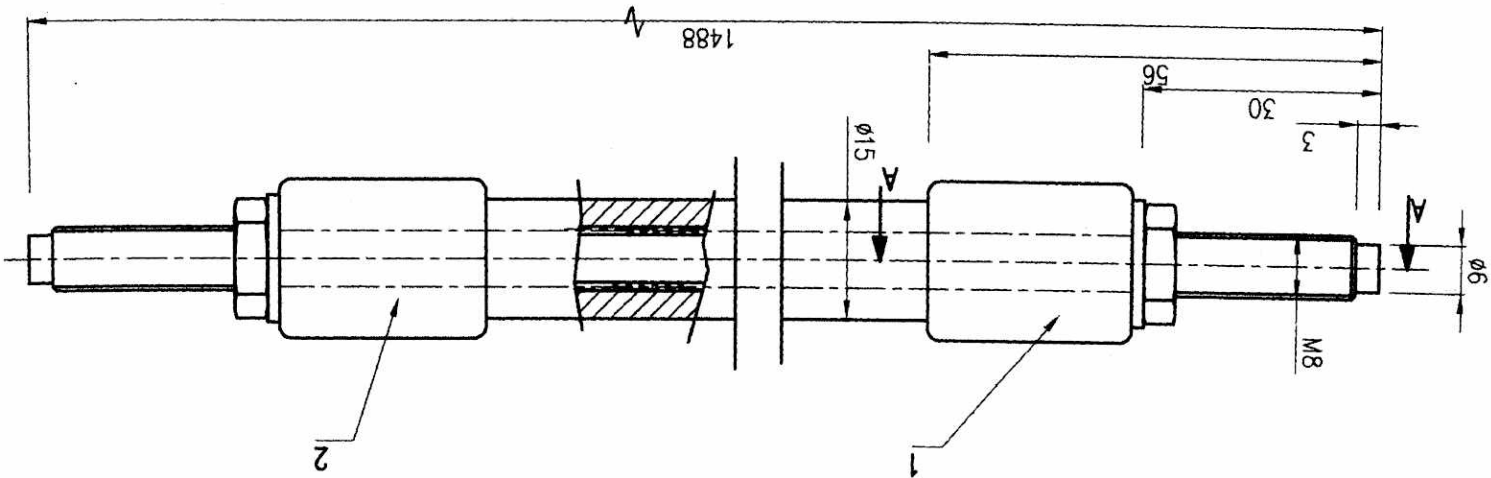

NOTE:  
 A- ELEMENT MUST GIVE 3KW AT 230 VOLTS  
 B- IT SHOULD NOT FAIL UPTO 250 VOLTS.  
 C- FULL LENGTH OF TUBE MUST BE SEEN GLOWING.  
 1&2 :- 3MM HOLES ON PERIPHERI TO BE INCORPORATED FOR THE ESCAPE OF GAS.  
 3000W - 230V

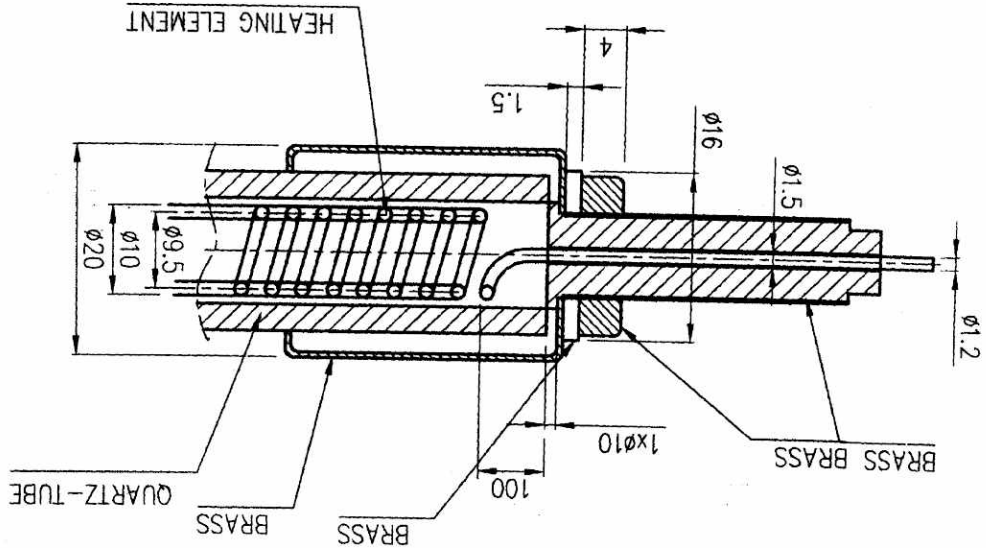

SECTION - A A

SCALE: 2:1

ITEM NO.	DESCRIPTION	DRAWING NO.	SIZE	RAW MATERIAL	MATERIAL CODE	NET WT.	GROSS WT.	QUANTITY

TYPE OF PRODUCT VARNISHING M/C OR 02-1311 F.NO:369  
 NAME OF CUSTOMER/PROJECT

**Bharat Heavy Electricals Ltd.**  
 HYDRABAD

RE: **B.PARANAND** SIGN: *B.P.*  
 CHD: **A.K.X.** SIGN: *A.K.X.*  
 APPD: **C.S.K.** SIGN: *C.S.K.*

DATE: 7-4-2011  
 DRN: 3/4/2011  
 VAR: 2/4/2011

REV.	DATE	ALTERED	CHECKED	APPD

DEPT. **FPD**  
 CODE **335**  
 GRADE OF TOL. DIM. C/M/F

REV.	NO. OF ITEMS	NO. OF

REF. TO ASSY DRG.

WEIGHT (KG)

SCALE

N.T.S.

REV.	NO. OF ITEMS	NO. OF

REF. TO ASSY DRG.

WEIGHT (KG)

SCALE

N.T.S.

REV.	NO. OF ITEMS	NO. OF

REF. TO ASSY DRG.

WEIGHT (KG)

SCALE

N.T.S.

REV.	NO. OF ITEMS	NO. OF

REF. TO ASSY DRG.

WEIGHT (KG)

SCALE

N.T.S.

REV.	NO. OF ITEMS	NO. OF

REF. TO ASSY DRG.

WEIGHT (KG)

SCALE

N.T.S.

REV.	NO. OF ITEMS	NO. OF

REF. TO ASSY DRG.

WEIGHT (KG)

SCALE

N.T.S.

REV.	NO. OF ITEMS	NO. OF

REF. TO ASSY DRG.

WEIGHT (KG)

SCALE

N.T.S.

REV.	NO. OF ITEMS	NO. OF

REF. TO ASSY DRG.

WEIGHT (KG)

SCALE

N.T.S.

REV.	NO. OF ITEMS	NO. OF

REF. TO ASSY DRG.

WEIGHT (KG)

SCALE

N.T.S.

REV.	NO. OF ITEMS	NO. OF

REF. TO ASSY DRG.

WEIGHT (KG)

SCALE

N.T.S.

REV.	NO. OF ITEMS	NO. OF

REF. TO ASSY DRG.

WEIGHT (KG)

SCALE

N.T.S.

REV.	NO. OF ITEMS	NO. OF

REF. TO ASSY DRG.

WEIGHT (KG)

SCALE

N.T.S.

REV.	NO. OF ITEMS	NO. OF

REF. TO ASSY DRG.

WEIGHT (KG)

SCALE

N.T.S.

REV.	NO. OF ITEMS	NO. OF

REF. TO ASSY DRG.

WEIGHT (KG)

SCALE

N.T.S.

REV.	NO. OF ITEMS	NO. OF

REF. TO ASSY DRG.

WEIGHT (KG)

SCALE

N.T.S.

REV.	NO. OF ITEMS	NO. OF

REF. TO ASSY DRG.

WEIGHT (KG)

SCALE

N.T.S.

REV.	NO. OF ITEMS	NO. OF

REF. TO ASSY DRG.

WEIGHT (KG)

SCALE

N.T.S.

REV.	NO. OF ITEMS	NO. OF

REF. TO ASSY DRG.

WEIGHT (KG)

SCALE

N.T.S.

REV.	NO. OF ITEMS	NO. OF

REF. TO ASSY DRG.

WEIGHT (KG)

SCALE

N.T.S.

REV.	NO. OF ITEMS	NO. OF

REF. TO ASSY DRG.

WEIGHT (KG)

SCALE

N.T.S.

REV.	NO. OF ITEMS	NO. OF

REF. TO ASSY DRG.

WEIGHT (KG)

SCALE

N.T.S.

REV.	NO. OF ITEMS	NO. OF

REF. TO ASSY DRG.

WEIGHT (KG)

SCALE

N.T.S.

REV.	NO. OF ITEMS	NO. OF

REF. TO ASSY DRG.

WEIGHT (KG)

SCALE

N.T.S.

REV.	NO. OF ITEMS	NO. OF

REF. TO ASSY DRG.

WEIGHT (KG)

SCALE

N.T.S.

REV.	NO. OF ITEMS	NO. OF

REF. TO ASSY DRG.

WEIGHT (KG)

SCALE

N.T.S.

REV.	NO. OF ITEMS	NO. OF

REF. TO ASSY DRG.

WEIGHT (KG)

SCALE

N.T.S.

REV.	NO. OF ITEMS	NO. OF

REF. TO ASSY DRG.

WEIGHT (KG)

SCALE

N.T.S.

REV.	NO. OF ITEMS	NO. OF

REF. TO ASSY DRG.

WEIGHT (KG)

SCALE

N.T.S.

REV.	NO. OF ITEMS	NO. OF

REF. TO ASSY DRG.

WEIGHT (KG)

SCALE

N.T.S.

REV.	NO. OF ITEMS	NO. OF

REF. TO ASSY DRG.

WEIGHT (KG)

SCALE

N.T.S.

REV.	NO. OF ITEMS	NO. OF

REF. TO ASSY DRG.

WEIGHT (KG)

SCALE

N.T.S.

REV.	NO. OF ITEMS	NO. OF

REF. TO ASSY DRG.

WEIGHT (KG)

SCALE

N.T.S.

REV.	NO. OF ITEMS	NO. OF

REF. TO ASSY DRG.

WEIGHT (KG)

SCALE

N.T.S.

REV.	NO. OF ITEMS	NO. OF

REF. TO ASSY DRG.

WEIGHT (KG)

SCALE

N.T.S.

REV.	NO. OF ITEMS	NO. OF

REF. TO ASSY DRG.

WEIGHT (KG)

SCALE

N.T.S.

REV.	NO. OF ITEMS	NO. OF

REF. TO ASSY DRG.

WEIGHT (KG)

SCALE

N.T.S.

REV.	NO. OF ITEMS	NO. OF

REF. TO ASSY DRG.

WEIGHT (KG)

SCALE

N.T.S.

REV.	NO. OF ITEMS	NO. OF

REF. TO ASSY DRG.

WEIGHT (KG)

SCALE

N.T.S.

REV.	NO. OF ITEMS	NO. OF

REF. TO ASSY DRG.

WEIGHT (KG)

SCALE

N.T.S.

REV.	NO. OF ITEMS	NO. OF

REF. TO ASSY DRG.

WEIGHT (KG)

SCALE

N.T.S.

REV.	NO. OF ITEMS	NO. OF

REF. TO ASSY DRG.

WEIGHT (KG)

SCALE

N.T.S.

REV.	NO. OF ITEMS	NO. OF

REF. TO ASSY DRG.

WEIGHT (KG)

SCALE

N.T.S.

REV.	NO. OF ITEMS	NO. OF

REF. TO ASSY DRG.

WEIGHT (KG)

SCALE

N.T.S.

REV.	NO. OF ITEMS	NO. OF

REF. TO ASSY DRG.

WEIGHT (KG)

SCALE

N.T.S.

REV.	NO. OF ITEMS	NO. OF

REF. TO ASSY DRG.

WEIGHT (KG)

SCALE

N.T.S.

REV.	NO. OF ITEMS	NO. OF

REF. TO ASSY DRG.

WEIGHT (KG)

SCALE

N.T.S.

REV.	NO. OF ITEMS	NO. OF

REF. TO ASSY DRG.

WEIGHT (KG)

SCALE

N.T.S.

REV.	NO. OF ITEMS	NO. OF

REF. TO ASSY DRG.

WEIGHT (KG)

SCALE

N.T.S.

REV.	NO. OF ITEMS	NO. OF

REF. TO ASSY DRG.

WEIGHT (KG)

SCALE

N.T.S.

REV.	NO. OF ITEMS	NO. OF

REF. TO ASSY DRG.

WEIGHT (KG)

SCALE

N.T.S.

REV.	NO. OF ITEMS	NO. OF

REF. TO ASSY DRG.

WEIGHT (KG)

SCALE

N.T.S.

REV.	NO. OF ITEMS	NO. OF

REF. TO ASSY DRG.

WEIGHT (KG)

SCALE

N.T.S.

REV.	NO. OF ITEMS	NO. OF

REF. TO ASSY DRG.

WEIGHT (KG)

SCALE

N.T.S.

REV.	NO. OF ITEMS	NO. OF

REF. TO ASSY DRG.

WEIGHT (KG)

SCALE

N.T.S.

REV.	NO. OF ITEMS	NO. OF

REF. TO ASSY DRG.

WEIGHT (KG)

SCALE

N.T.S.

REV.	NO. OF ITEMS	NO. OF

REF. TO ASSY DRG.

WEIGHT (KG)

SCALE

FIRST ANGLE P JECTION

(ALL ENSIONS ARE IN mm)

DRG. NO.

3.2 / 1.6 / 0.8

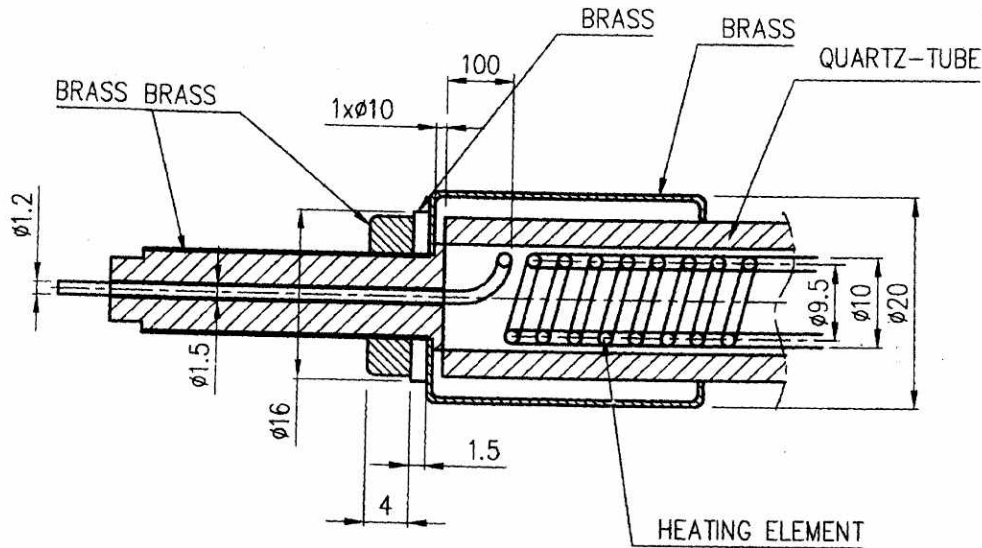
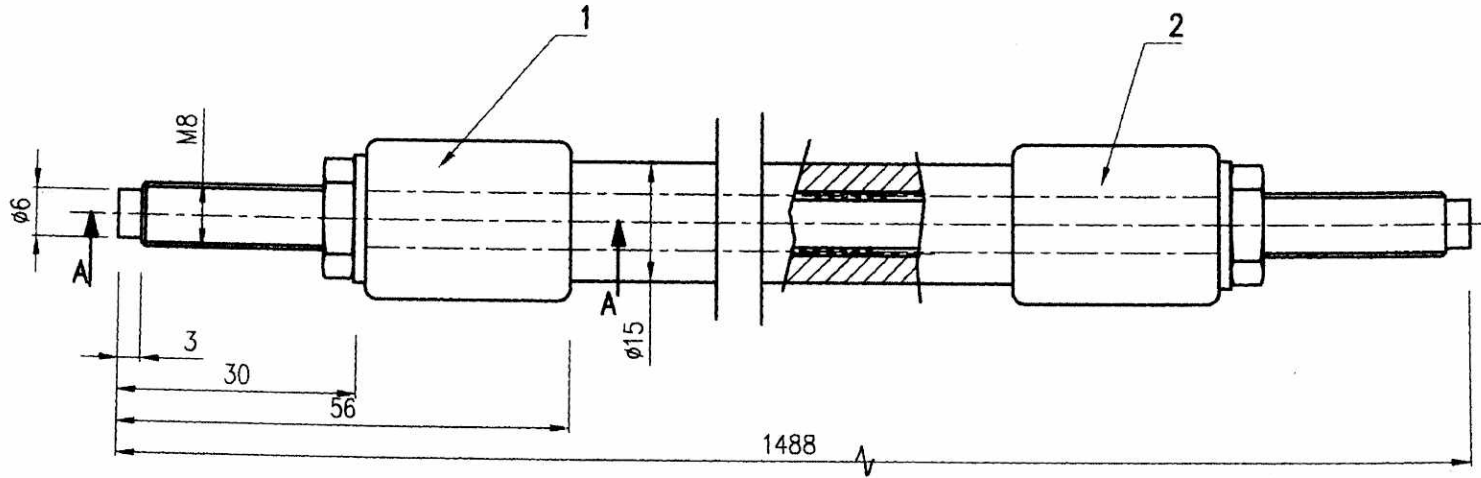

SECTION - A A

SCALE : 2 : 1

NOTE:

- A- ELEMENT MUST GIVE 3KW AT 230 VOLTS
  - B- IT SHOULD NOT FAIL UPTO 250 VOLTS.
  - C- FULL LENGTH OF TUBE MUST BE SEEN GLOWING RED.
- 1&2 :-  $\phi$ 3MM HOLES ON PERPHERI TO BE INCORPORATED FOR THE ESCAPE OF GAS.  
3000W - 230V

ITEM NO.	DESCRIPTION	DRAWING NO.	RAW MATERIAL SIZE	MATERIAL CODE	NET WT.	GROSS WT.					
				MATERIAL SPECN	QUANTITY						
TYPE OF PRODUCT VARNISHING M/C				02-1311 F.NO:369							
OR											
NAME OF CUSTOMER/PROJECT											
		<b>BHARAT HEAVY ELECTRICALS LTD.</b> <b>HYDERABAD</b>		RE DRN.	NAME	SIGN	DATE	NO.OF VAR.			
				CHD.	B.PARAMANAND	<i>(Signature)</i>	7-4-2k				
				APPD.	A.K.X.	<i>(Signature)</i>	7/4/2k				
					C.S.K.	<i>(Signature)</i>	7/4/2000				
REV.	DATE	ALTERED	CHECKED	APPD	DEPT.	GRADE OF TOL.DIM. C/M/F	SCALE	WEIGHT (KG)	REF. TO ASSY DRG.	ITEM NO.	NO.OF ITEMS
01					FP&D	335	N.T.S				
ORIGINAL REDRAWN 250V TO 200V DIM-100 ADDED 12495 A,B&C ADDED					TITLE <b>INFRA-RED HEATER</b>		CARD CODE	DRAWING NO. <b>3-RS-0888</b>		REV. 01	