



ISO 9001:2008,  
14001:2004,  
50001:2011 &  
OHSAS 18000  
MAHARATNA  
COMPANY

**MATERIAL MANAGEMENT (PURCHASE)  
CENTRAL FOUNDRY FORGE PLANT, BHEL HARDWAR  
RANIPUR, HARIDWAR (INDIA) – 249403**

Phone No.+91-1334-281277/284684, FAX No. 225892  
e-mail : v\_kumar@bhelhwr.co.in; rohit\_v@bhelhwr.co.in;  
ranjank@bhelhwr.co.in

**Sub:** Open Tender Enquiry No: 201600871/5409 due on 18.06.2016, at 2.00 PM

Dear Sir,

We are pleased to invite offer in **E-Tender** as per enclosed specifications & terms and conditions for the under mentioned items.

SI No	Tender No	Description of Material	Qty	Date & Time Of Opening
01	201600871/5409	Material Code: <b>FF2618081013</b> Resin Bonded Magnesia Carbon Bricks (RBMS-SPL) - Heavy Duty. Spec: FF05066 Rev 05 Size: Furnace Bricks, size=30/20	7000 Nos.	18.06.16 at 2.00 PM
02		Material Code: <b>FF2618081021</b> Resin Bonded Magnesia Carbon Bricks (RBMS-SPL) - Heavy Duty. Spec: FF05066 Rev 05 Size: Furnace Bricks, size=30/40	3000 Nos.	
03		Material Code: <b>FF2618081030</b> Resin Bonded Magnesia Carbon Bricks (RBMS-SPL) - Heavy Duty. Spec: FF05066 Rev 05 Size: Ladle Bricks, Drawing of SU745	40000 Nos.	
04		Material Code: <b>FF2618081064</b> Resin Bonded Magnesia Carbon Bricks (RBMS-SPL) - Heavy Duty for Bottom of VAD Ladles. As per clause 6.2.2 of specification Spec: FF05066 Rev 05 Size: 225X250X100 MM	2000 Nos.	

Kindly read terms and conditions, Offer not in accordance with the instructions is liable to be disqualified or ignored.

Please visit [www.bhel.com](http://www.bhel.com) or [www.bhelhwr.co.in](http://www.bhelhwr.co.in) for more details & corrigendum if any for the tender enquiry.

Offers are to be submitted online in E-tender portal at <https://bheleps.buyjunction.in/>

**Offer to be submitted only on e-procurement portal. Hard copy of offer is not required to be submitted to CFFP. Any offers received in Hard copy shall not be accepted and straightaway rejected by CFFP.**

Before proceeding for submitting quotation in e-portal, supplier to ensure that they are having a valid Digital Signature Certificate (DSC). Valid DSC refers to an Active Signing and Encryption Certificate (both), with specification Class III SHA2 2048 bit

Unregistered vendors should download Vendor Registration Form and submit same duly filled along with offer.

Thanking You,

Yours Faithfully,  
For & On behalf of CFFP, BHEL, Hardwar

(Vipin Kumar)  
Engineer (Purchase)

**Note:** Corrigendum if any shall not be published, kindly refer websites for any changes.

## PRE QUALIFICATION REQUIREMENT

**Ref: Tender enquiry no. 201600871/5409**

Pre-qualification criteria for above tender enquiry are as under:

- (a) Vendor must be Manufacturer/ Manufacturing Agent of these bricks and must have supplied Magnesia carbon bricks with MgO content= 97% minimum in fused magnesia used and supplied steel Industry in one financial year within last three years (after 01.04.2013) from the date of opening tender.
- (b) As a supporting document, copy of Purchase Order/Purchase Agreements/ Invoice of cumulative minimum as per following table for Magnesia carbon bricks with MgO content=97% minimum in fused magnesia used and supplied to a steel Industry in one financial year within last three years (after 01.04.2013) from the date of opening tender has to be provided.

**Table:**

<b>Item</b>	<b>Item wise requirement of PO having minimum quantity of Magnesia Carbon bricks required</b>
RBMC Bricks for VAD/VOD Ladle (FF2618081030)	8000 nos.
RBMC Brick for 30T &10T EAF (FF2618081013)& (FF2618081021)	2000 nos.
RBMC Bottom Bricks (FF2618081064)	400 nos.

**Note:** (1) If a PO consist of 8000 nos of Magnesia carbon bricks then it is qualified for all three items.

(2) If a PO consist of 2000 nos. of bricks Magnesia carbon bricks then it is qualified for RBMC Bricks for 30T & 10T EAF and RBMC Bottom Brick.

Name of Vendor:.....

**Non-negotiable terms of tender enquiry**

Confirmation/comments on the conditions given below are mandatory. Please confirm the following or else your offer is liable to be rejected.

	Description	Vendor Confirmation /Comment (In case of blank, it shall be deemed to be accepted by vendor)
1	Purchase Order will be placed on Original manufacturer even if the offer is submitted by Manufacturer's authorized Agent.	
2	Authorization letter (for Indian manufacturers)/Agency Agreement for (Foreign Manufacturers) has to be provided by Manufacturer's Authorized Agent.	
3	Vendor has to Guarantee Performance of Bricks as per Clause 10.0 of Specification FF05066 R05	
4	<p>Third party inspection shall have to be arranged by supplier from any of the six inspection agencies namely: BVC, DNV, TUV(SUD), Alfred H Knight, SGS, Alec Steward at their cost.</p> <p><b><u>Scope of third party Inspection:</u></b> Physical properties and Chemical Composition of the Bricks at Manufacturer end as per Clause no. 5.1 &amp; 5.2 of CFFP Specification no. FF05066 R05. Physical and Chemical properties to be witnessed by third party inspection agency (except 5.2a- which is to be reviewed)</p>	
5	<p><b><u>Payment Term:</u></b> <b><u>For Indigenous Vendors:</u></b> - 80% payment within 30 days after receipt &amp; acceptance of material at CFFP / BHEL, Haridwar through e-payment. - Balance 20% payment shall be released after use and checking of performance of the bricks w.r.t performance criteria cl 10.0 of the specification FF05066 R05. Approximate schedule for payment shall be around 10 months from receipt date.</p> <p><b><u>For foreign suppliers:</u></b> - 80% Payment through USANCE LC on 70<sup>th</sup> day of bill of lading (BL) date. Bank charges - Either Side (i.e. in India to BHEL account &amp; in Beneficiary country to Vendor's account). In case of amendment to LC for reasons attributable to vendor, all bank charges (both sides) shall be to Vendor's account. - Balance 20% payment shall be released through direct e-payment to vendor's account after use and checking of performance of the bricks w.r.t performance criteria clause 10.0 of the specification FF05066 R05. Approximate schedule for payment shall be around 12 months from BL date (considering 45-60 days' time for receipt of material at CFFP from BL date).</p> <p>In case vendors do not agree to 20% direct payment after performance checking at CFFP, bank guarantee for equal amount shall have to be submitted by vendor for the specified period. In case Bricks do not perform as per the specified criteria, CFFP BHEL shall invoke the Bank Guarantee submitted by Vendor. <u>Any other term shall not be acceptable for this 20% payment.</u></p> <p><b><u>Loading Criteria:</u></b> * In case of 20% payment against Bank Guarantee, loading of interest for the above specified payment period shall be done to the offers for calculating the landed cost at CFFP. * In case vendor does not agree for payment of 80% amount as per above payment term, proper loading shall be done. Base rate of SBI (as applicable on the date of bid opening: Techno commercial bid opening in case of two part bids) + 6%, shall be considered for loading for the period of relaxation sought by bidders.</p>	
6	In case of rejection of material after receipt at CFFP, vendor/supplier is required to take back the rejected material at their cost within 45 days from the date of rejection memo/ note. If vendor/supplier fails to take back the rejected material from CFFP within 90 days from the date of rejection memo/ note, CFFP has the right to dispose-off the rejected material at the risk & cost of the vendor/ supplier and no further claim for the rejected material will be entertained.	
7	Item no. 1 (Furnace Bricks 30/20) & 2 (Furnace Bricks 30/40) of Enquiry shall be procured from same source/vendor. L1 status shall be determined for both items taken together.	
8	Item no. 3 (SU 745) & 4 (Bricks for Bottom Lining of Ladles) of Enquiry shall be procured from same source/vendor. L1 status shall be determined for both items taken together.	

**Note:**

1. This annexure duly filled is to be submitted along with offer through E-tender.
2. The above terms are non-negotiable and non-acceptance of the above terms shall disqualify the offer from this tender enquiry.

Date:

(Signature)



# PLANT PURCHASE SPECIFICATION

(CFFP - HARDWAR)

**FF 05066 Rev 5**

**Page 1 of 7**

## HEAVY DUTY RESIN BONDED MAGNESIA CARBON BRICKS (RBMC SPL) BRICKS FOR EAF & VAD,VOD & LRF LADLES

**1.0 GENERAL:**

This specification governs the quality requirements of RBMC-Special bricks for EAF, VAD, VOD & LRF ladles.

**2.0 APPLICATION:**

- \***Metal and slag zone of Electric Arc Furnaces.** Oxygen lancing is done in EAF for melting and reducing **Phosphorous to 0.004%**.
- \* **Bottom, metal and slag zone of ladles.** Oxygen lancing in ladles during VOD operation.
- \* Degassing under vacuum at  $\leq 1$  Tor for 30 minute at Temp. 1720°C(max) to reduce gas contents and achieve Sulphur  $\approx 0.002\%$ .
- \*Typical final slag composition after secondary refining is as follows: Cao 40-45%, SiO<sub>2</sub> 13- 17%, MgO 10-12%, Al<sub>2</sub>O<sub>3</sub> 20-25%, Fe<sub>2</sub>O<sub>3</sub> 1.5-3%, Cr<sub>2</sub>O<sub>3</sub>+MnO <1.2%

**3.0 CONDITION OF DELIVERY**

The different types of bricks shall be supplied as per sizes and drawings indicated at page number 5 and 6 of this specification.

- \* Used to brick slag and metal zone of
  - 6.1: EAF of capacity of 10T and 30T
  - 6.2.1: VAD, VOD and LRF ladles
  - 6.2.2: Bottom bricks of VAD, VOD & LRF
  - 6.3: EAF of 70T
  - 6.4: Tap hole refractory for EBT of 70T EAF

**4.0 COMPLIANCE WITH NATIONAL STANDARDS**

There is no Indian standard of resin bonded Magnesia Carbon bricks.

**5.0 PROPERTIES:**

When tested in accordance with the relevant clauses of **IS-1528 or any other International Standard/ Validated instrumental analysis traceable to international standards**, the test samples shall show the following values.

**5.1: PHYSICAL PROPERTIES:**

Bulk Density (gm /cc)	3	(Min)
Apparent Porosity	5%	(Max)
C.C.S (N/mm <sup>2</sup> )	35	(Min)
Refractoriness Under Load	1600°C	(Min)
Thermal expansion up to 1400°C	2%	(Max)
HMOR, (Kg/Cm <sup>2</sup> ) AT 1400C*30 minutes	125	(Min)

RMI	S.N GHOSH	<i>S.N Ghosh</i>	WORKED BY	M.K SAHU	<i>M.K Sahu</i>
MPIC	A.K.KUSWAHA	<i>A.K Kuswaha</i>	CHECKED BY	SUNIL KUMAR	<i>Sunil Kumar</i>
CHAIRMAN CPSC	V K AGARWAL	<i>V.K Agarwal</i>	SUPERVIDED BY	P.K.ROY	<i>P.K Roy</i>
			APPROVED :	<b>PLANT STANDARDS COMMITTEE</b>	
			PREPARED :	SMS TECH	ISSUED : Steel Melting Shop
					DATE <b>27-04-16</b>

COPYRIGHT AND CONFIDENTIAL  
The information on this document is the property of Bharat Heavy Electrical Limited. It must not be used directly or indirectly in any way detrimental to the interest of the company.



# PLANT PURCHASE SPECIFICATION

(CFFP - HARDWAR)

FF 05066 Rev 5

Page 2 of 7

## 5.2 CHEMICAL COMPOSITION:

SL NO.	ELEMENTS	CONTENT	
		%(Min)	%(Max)
a)	MgO (in fused magnesia used)	97	
b)	MgO (in finished product)	82	
c)	Residual carbon (British cocking test)	8	12
d)	Al <sub>2</sub> O <sub>3</sub>		2.0
e)	CaO		2.0
f)	SiO <sub>2</sub>		1.5
g)	Fe <sub>2</sub> O <sub>3</sub>		0.5

## 6.0: TYPES OF BRICK.

	DESCRIPTION	SIZE	a mm	b mm	h mm	l mm	r mm	A deg
6.1	Bricks for Lining of 30t and 10T EAF	30/20	160	140	300	100	2100	-
		30/40	170	130	300	100	-	-
6.2.1	Bricks for side wall lining of ladles	SU 745	210	185.2	100	177.8	-	8
6.2.2	Bricks for bottom lining of ladles	Bottom Bricks	225	250	100	-	-	-

Drawing of bricks are given in page no 4

## 6.3: Bricks for lining of 70TEAF:

Quantity indicated below is for one set of lining

Sl no	Bricks size	Quantity(Numbers)
1	400x190/110x100mm	150
2	400x170/130x100mm	500
3	400x160/140x100mm	360
4	350x170/130x100mm	100
5	350x160/140x100mm	342
6	400x150/100mm	402
7	350x150/100mm	128

(Dimensional tolerances: ±1.5% or 2mm which is greater)

WORKED BY

M K SAHU

23/4/16

CHECKED BY

SUNIL KR.

28/4/16

COPYRIGHT AND CONFIDENTIAL

The information on this documents is the property of Bharat Heavy Electrical Limited It must not be used directly or indirectly in any way detrimental to the interest of the company

# PLANT PURCHASE SPECIFICATION

(CFFP - HARDWAR)

FF 05066 Rev 5



Page 3 of 7

## 6.4. TAP HOLE REFRACTORIES FOR 70T EAF:

Size and set as per drawing given at page no 5 of 7.

## 7.0 INSPECTION AT SUPPLIER'S WORKS:

- CFFP reserves the right to witness the testing of the material at supplier works and therefore the supplier shall notify the readiness of the material in advance.
- CFFP may, at its discretion, test the material after receipt and acceptance of the material will be based on the CFFP's test results. ***In case of any dispute in chemical analysis referee method shall be IS.***
- For result of analysis and properties of material the decision of CFFP shall be final and binding on the supplier.

## 8.0 TEST CERTIFICATES:

One Original and three copies of Test Certificate from the **Manufacturer** containing the following information **along with test result of all properties given in clause no 5 should be provided. The T.C should contain the packing details of material.**

Manufacturer's Name  
Name of the material  
Batch/Lot No.  
Quantity.

**The TC should also contain the BHEL's P.O. No. and Challan No. and packing detail of the material.**

## 9.0 PACKING AND MARKING:

Packing should be such as to prevent loss / deterioration in quality during handling, transport and storage. It should be in the **Manufacturer's packing**. Each package should be marked with the following details.

Name of the material  
Manufacturer's Name / Trade mark  
Batch/Lot No.  
Net weight.

WORKED  
BY

MKSAHU

 23/04/16

CHECKED  
BY

SUNIL KR.

 23/04/16

COPYRIGHT AND CONFIDENTIAL

The information on this document is the property of Bharat Heavy Electricals Limited. It must not be used directly or indirectly in any way detrimental to the interest of the company.



## PLANT PURCHASE SPECIFICATION

(CFFP - HARDWAR)

### 10.0 PERFORMANCE OF MATERIAL:

Guaranteed heat in working lining (**Slag zone + Metal zone**) of EAF and VAD/VOD/LRF, under working conditions mentioned below against types of bricks.

Equipment.	Bricks	Working condition	LIFE
30T&10T EAF	30/20 & 30/40	Oxygen lancing, removal of P to 0.004%	80 heats minimum with intermediate repair near tap hole area and arch cooler area.
70T EAF	SET	Oxygen lancing, removal of P to 0.004%	25 Heats minimum
VAD/VOD/LRF Ladles	SU 745	Temp achieved-1720°C Max Degassing at Vacuum level $\leq 1$ torr for $\approx 30$ minutes	<b>Minimum 5000</b> minutes of purging with one slag line repair.

#### Record of Life:

Furnace life → Record from **Heat Process Sheet/Furnace Log Book**.

Ladle life → Record from **Heat Process Sheet/Ladle Life Record Book** in pit side.

### 11.0 ACCEPTANCE OF MATERIAL:

Acceptance of material will be based on conditions defined in clause number 5 and 6 and drawings mentioned in page 5 and 6 of the specification.

WORKED  
BY

M K SAHU

23/4/16

CHECKED  
BY

SUNIL KR.

23/04/16



# PLANT PURCHASE SPECIFICATION

(CFFP - HARDWAR)

FF 05066 Rev 5

Page 5 of 7

**COPYRIGHT AND CONFIDENTIAL.**  
The information on this documents is the property of Bharat Heavy Electrical Limited. It must not be used directly or indirectly in any way detrimental to the interest of the company.

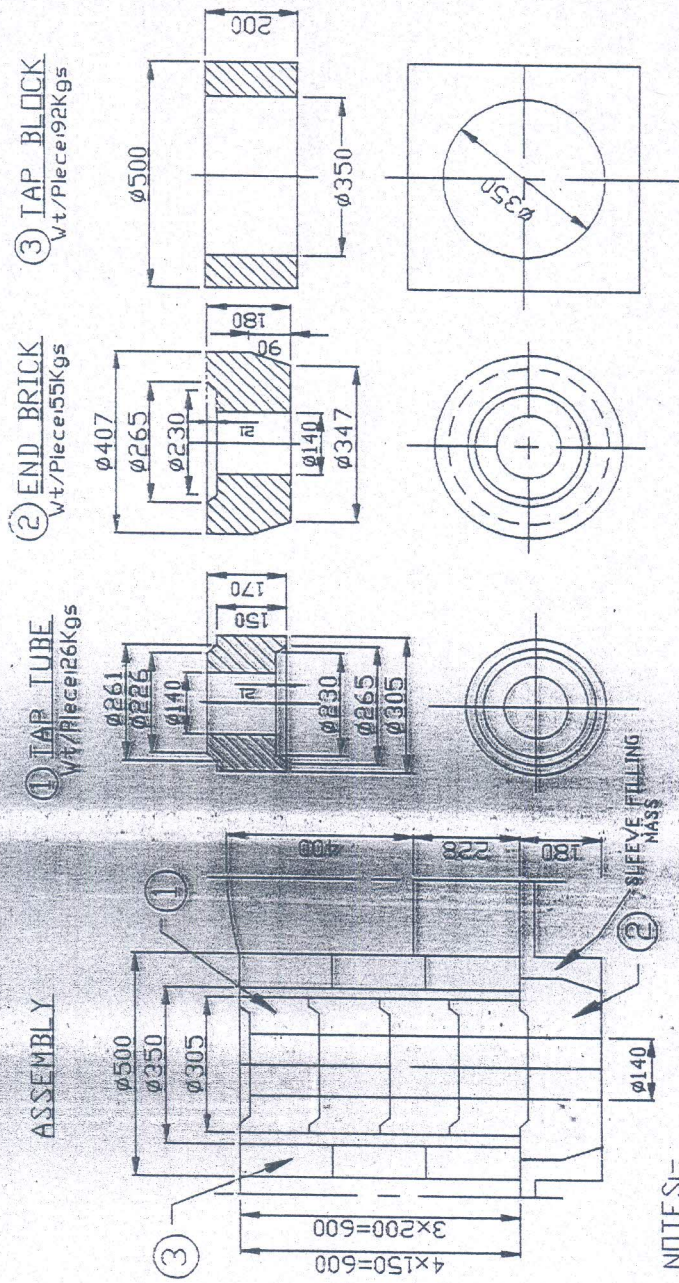

1. ONE SET CONSISTS OF 4 NOS. OF ITEM 1, 1 NO. OF ITEM 2, 3 NOS. OF ITEM 3

WORKED BY	M KSAHU		23/4/16
CHECKED BY	SUNIL KR.		23/04/16



# PLANT PURCHASE SPECIFICATION

(CFFP - HARDWAR)

FF 05066 Rev 5

Page 6 of 7

COPYRIGHT AND CONFIDENTIAL

The information on this document is the property of Bharat Heavy Electrical Limited. It must not be used directly or indirectly in any way detrimental to the interest of the company.

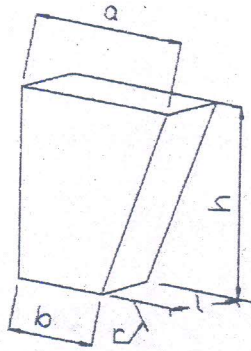

SIZE: 30/20 & 30/40

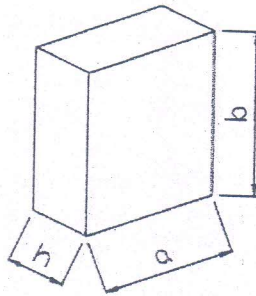

BOTTOM BRICK

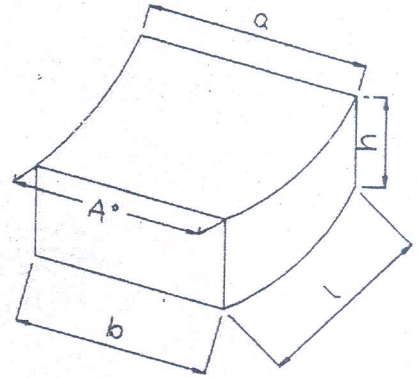

SIZE: SU 745

WORKED BY

M KSAHU

23/4/16

CHECKED BY

SUNIL KR.

28/04/16



# PLANT PURCHASE SPECIFICATION

(CFFP - HARDWAR)

FF 05066 Rev 5

Page 7 of 7

## REVISION RECORD SHEET

SL NO	REVISION NO	DATE	
1	03	17.07.2006	-Packing clause modified
2	04	20.04.2010	1- Clause 5 modified. 1. MgO % changed from 94.5%min to 97% min and this is in used magnesia. Residual carbon % changed to 8-12%from max of 12%.Al <sub>2</sub> O <sub>3</sub> content changed to 2.0% max from 0.65%max.Fe <sub>2</sub> O <sub>3</sub> content limited to 0.5%. 2- DBMC spl. bricks removed from spec. Tap hole Refractory for 70TEAF incorporated in the spec. SU 645 size removed. 3- Clause no 7: inspection by third party included. 4- Clause no 8: All properties mentioned at Clause no % are to be given in T.C. The T.C should contain the packing details.
3	05	23/04/2016	1. Clause no 02 modified, working condition, temp and vacuum level specified. Final slag composition mentioned. 2.- Clause no 05 modified: Validated instrumental Analysis traceable to internal standards added. 3.- <b>clause no 5.3</b> chemical composition MgO in finished product added. 4.- Clause no 6.3: number of bricks at sl. No 1,2 and 4 (for 70T) increased. 4.- <b>Clause no 7</b> modified: in case of any dispute in chemical analysis referee method shall be IS 5.- <b>Clause no 10</b> performance of material : life of bricks in EAF & Ladles mentioned. 6.- Clause no 11, acceptance criteria added.

COPYRIGHT AND CONFIDENTIAL

The information on this documents is the property of Bha. Heavy Electrical Limited It must not be used directly or indirectly in any way detrimental to the interest of the company

WORKED BY

MK SAHU

28/4/16

CHECKED BY

SUNIL KR.

23/04/16

## **GENERAL TERMS AND CONDITIONS OF TENDER ENQUIRY THROUGH E-TENDER**

CFFP/TE/GTC/E R00 DT:07.03.2016

1. Offer to be submitted only on e-procurement portal. Hard copy of offer is not required to be submitted to CFFP. Any offers received in Hard copy (for E-Tender Enquiries) shall not be accepted and straightaway rejected by CFFP.
2. Responsibility for submission of tender in time solely lies with vendor. Vendors are requested to submit offers well in advance of due date & time.
3. Foreign template (for offer submission) to be selected only by Foreign vendor on whom order is to be placed. Offers submitted by Indian/Indigenous vendors in foreign template shall not be accepted for that enquiry.
4. Price to be quoted only in UNIT as mentioned in enquiry for that item.
5. Vendor to specify details of product offered and attach any technical literature/ data sheet/ drawing as applicable for the product offered.
6. Offer must be submitted strictly in line with specification, terms & conditions of enquiry else offer is likely to be ignored. Deviations if any to be indicated clearly in the spaces provided for deviations.
7. All commercial terms i.e. packing & forwarding, Custom duty, Additional Duty, VAT/CST, Excise Duty/CVD. Bank charges, Freight, payment terms & Insurance etc if any as applicable must be specified correctly in amount or in percentage in respective fields.
8. Evaluation for L1 status shall be done on basis of Landed cost net of Cenvat at CFFP.
9. Standard Payment terms:  
For indigenous suppliers: 100% within 30 days after receipt & acceptance of material at CFFP / BHEL, Haridwar through e-payment.  
For foreign suppliers: Payment through USANCE LC on 70th day of bill of lading date. Bank charges - Either Side (i.e. in India to BHEL account & in Beneficiary country to Vendor's account). In case of amendment to LC for reasons attributable to vendor, all bank charges (both sides) shall be to Vendor's account.
10. In case VAT is applicable, VAT to be charged extra without any concessional form. VAT amount shall be released / paid to vendor after having obtained a confirmation (copy of Challan) that VAT amount has been paid to the Uttarakhand Commercial Tax Department.
11. In case CST is applicable, CST to be charged extra against form C.
12. Original manufacturer's Test Certificate is required along with dispatch documents. In case supplies are from traders, it shall be the responsibility of the trader to provide Original manufacturer's test certificate with linkage to traders invoice stating batch no.
13. CFFP/BHEL, Haridwar reserves the right to reject any or all tenders without assigning any reason thereof.
14. BHEL reserves the right to place PO for part / full qty.
15. BHEL reserves the right to place PO on more than one source as specified in splitting condition of tender enquiry (if applicable for that enquiry).
16. In case Foreign vendor takes services of an Indian Agent, Agency Agreement to be compulsorily submitted alongwith offer. In absence of Agency Agreement, BHEL shall not deal with Agent and shall deal directly with Foreign Principal. Role and scope of work/services rendered by Indian Agent alongwith agency commission of Agent to be clearly specified in Agreement.
17. CFFP/BHEL, Haridwar may opt for E-auction/Reverse auction for obtaining prices for part or full tendered quantity. BHEL also reserve the right to negotiate price with L1 vendor after reverse auction.
18. In case vendor is not registered with CFFP BHEL Haridwar for this material, duly filled 'Supplier Registration Form' must be submitted within 15 days of opening of tender (form available on website [www.bhelhwr.co.in](http://www.bhelhwr.co.in) & [www.bhel.com](http://www.bhel.com)).

## **GENERAL TERMS AND CONDITIONS OF TENDER ENQUIRY THROUGH E-TENDER**

CFFP/TE/GTC/E R00 DT:07.03.2016

19. EMD/Security Deposit/ Tender fees shall be as specified in tender enquiry (if applicable for that enquiry).
20. Offers of the bidders who are on the banned list as also the offers of the bidders, who engage the services of the banned firms shall be rejected. The list of banned firms is available on website [www.bhel.com](http://www.bhel.com)
21. Inspection: Final inspection of material shall be done after receipt of material at CFFP/BHEL, Hardwar. Acceptance of material shall be after final inspection and shall be binding. However, CFFP reserves the right to pre Inspect the material at supplier works. In case material is found defective during warranty period, the same will be returned for repair and/ or replacement. For this vendor has to bear all the charges such as Freight, to and fro insurance etc. Bank Guarantee for the equal amount to the cost of the item is to be furnished by vendor. In case the repair is done at CFFP/BHEL the amount on actual shall have to be reimbursed by the Vendor and or adjusted on actual from their bill.
22. The Bidder along with its associate/ collaborators/ sub-contractors/ sub-vendors/ consultants/ service providers shall strictly adhere to BHEL Fraud Prevention Policy displayed on BHEL website <http://www.bhel.com> and shall immediately bring to the notice of BHEL Management about any fraud or suspected fraud as soon as it comes to their notice.
23. Currency of Payment: Mention the currency in which payment has to be made. For evaluation of price bids, exchange rate (TT selling rate of SBI) as on scheduled date of tender opening (Part-1 bid in case of two part bid) shall be considered.
24. Agent/Agency Commission: Payment of any kind at any stage will not be made to agent on account of agent commission or otherwise by CFFP/BHEL, Hardwar.
25. In case of rejection of material after receipt at CFFP, vendor / supplier is required to take back the rejected material at their cost within 45 days from the date of rejection memo / note. If vendor/ supplier fails to take back the rejected material from CFFP within 90 days from the date of rejection memo / note, CFFP has the right to dispose-off the rejected material at the risk & cost of the vendor / supplier and no further claim for the rejected material will be entertained.
26. Penalty for late delivery: The delivery of the goods shall be made strictly as per time limit specified in delivery schedule of purchase order, failure to supply within this period will make the supplier liable to penalty of 1/2 (half) percent of the price of the goods in arrears per week subject to a maximum of 10%.  
In case of non-acceptance or partial acceptance, offer shall be loaded for the unaccepted portion (out of the maximum 10% penalty) to calculate landed cost.
27. Risk Purchase: In case of delayed/defective supplies or non-fulfilment of any other terms & conditions given in the Purchase Order, the purchaser may cancel the purchase order in full or part thereof and may also make the purchase of such material at the risk & cost of supplier.
28. Disputes: In event of any dispute arising out of contractual obligation, the order being finalized at Hardwar, India will be subject to Indian Laws and falls under jurisdiction of the court of Law at Haridwar, India. The overseas supplier shall also abide by the verdict of Court of Law at Hardwar, India. OR  
All disputes arising out of or in connection with the present contract, if any, shall be finally settled under the rules of arbitration of International chamber of commerce by one or more arbitrator appointed in accordance with the said Rules in India.
27. Any Term & condition of the specific tender (if specified in tender & contradicts with above term) will supersede the above general terms & conditions.

**Terms and conditions regarding Indian agent of foreign suppliers:**

01. BHEL shall deal directly with foreign vendors, wherever required, for procurement of goods. However, if the foreign principal desires to avail of the services of an Indian agent, then the foreign principal should ensure compliance to regulatory guidelines- which require mandatory submission of an Agency agreement.
02. It shall be incumbent on the Indian agent and the foreign principal to adhere to the relevant guidelines of Government of India, issued from time to time.
03. The agency agreement should specify the precise relationship between the foreign OEM/Foreign principal and their Indian agent and their mutual interest in the business. All services to be rendered by agent/associate, whether of general nature or in relation to the particular contract, must be clearly stated by the foreign supplier / Indian agent. Any payment, which the agent or associate receives in India or aboard from the OEM, whether as commission or as a general retainer fee should be brought on record in the agreement and be made explicit in order to ensure compliance to laws of the country.
04. Any agency commission to be paid by BHEL to the Indian agent shall be in Indian currency only.
05. Tax deduction at source is applicable to the agency commission paid to the Indian agent as per the prevailing rules.
06. In the absence of any agency agreement, BHEL shall not deal with any Indian agent (authorized representatives/ associate/consultant, or by whatever name called) and shall deal directly with the foreign principal only for all correspondence and business purposes.
07. The "Guidelines for Indian Agents of Foreign Suppliers" enclosed at annexure- 'A' shall apply in all such cases.
08. The supply and execution of the Purchase Order (including indigenous suppliers/service) shall be in the scope of the OEM/ Foreign principal. The OEM/ Foreign principal should submit their offer inclusive of all indigenous suppliers/services and evaluation will be based on 'total cost to BHEL'. In case OEM/ foreign principal recommends placement of order(s) towards indigenous portion of supplies/services on Indian Supplier (s)/ agent on their behalf, the credentials/capacity/capability of the Indian Supplier (s)/ agent to make the supplies/Services shall be checked by BHEL as per the extant guidelines of Supplier Evaluation, Approval and Review Procedure (SEARP), before opening of price bids. In this regards, details may be checked as per Annexure- 'B' (copy enclosed). It will be the responsibility of the OEM/ Foreign Principal to get acquainted with the evaluation requirements of Indian supplier/agent as per SEARP available on [www.bhel.com](http://www.bhel.com).

The responsibility for successful execution of the contract (including indigenous supplies/services) lies with the OEM/ foreign principal. All bank guarantees to this effect shall be in the scope of the OEM/Foreign principal.

**Guidelines for Indian Agents of Foreign Suppliers**

- 1.0 There shall be compulsory registration of agents for all Global (Open) Tender and Limited Tender. An agent who is not registered with BHEL shall apply for registration in the registration form in line with SEARP.
- 1.1 Registered agents will file an authenticated Photostat copy duly attested by a Notary Public/Original certificate of the Principal confirming the agency agreement and giving the status being enjoyed by the agent and the commission/ remuneration/ salary/ retainership being paid by the principal to the agent before the placement of order by BHEL.
- 1.2 Wherever the Indian representatives have communicated on behalf of their principals and the foreign parties have stated that they are not paying any commission to the Indian agents, and the Indian representative is working on the basis of salary or as retainer, a written declaration to this effect should be submitted by the party (i.e. Principal) before finalizing the order.
- 2.0 **Disclosure of particulars of agents/ representatives in India, if any.**
- 2.1 Tenderers of Foreign nationality shall furnish the following details in their offers:
  - 2.1.1 The Bidder(s)/ Contractor(s) of foreign origin shall disclose the name and address of the agents/ representatives in India if any and the extent of authorization and authority given to commit the Principals. In case the agent/ representative be a foreign Company, it shall be confirmed whether it is existing Company and details of the same shall be furnished.
  - 2.1.2 The amount of commission/ remuneration included in the quoted price(s) for such agents/ representatives in India.
  - 2.1.3 Confirmation of the Tenderer that the commission/ remuneration, if any, payable to his agents/ representatives in India, may be paid by BHEL in Indian Rupees only.
- 2.2 Tenderers of Indian Nationality shall furnish the following details in their offers:
  - 2.2.1 The Bidder(s)/ Contractor(s) of Indian Nationality shall furnish the name and address of the foreign principals, if any, indicating their nationality as well as their status, i.e. whether manufacturer or agents of manufacturer holding the Letter of Authority of the Principal specifically authorizing the agent to make an offer in India in response to tender either directly or through the agents/ representatives.
  - 2.2.2 The amount of commission/ remuneration included in the price (s) quoted by the Tenderer for himself.
  - 2.2.3 Confirmation of the foreign principals of the Tenderer that the commission/ remuneration, if any, reserved for the Tenderer in the quoted price(s), may be paid by BHEL in India in equivalent Indian Rupees on satisfactory completion of the Project or supplies of Stores and Spares in case of operation items.
- 2.3 In either case, in the event of contract materializing, the terms of payment will provide for payment of the commission/ remuneration, if any payable to the agents/ representatives in India in Indian Rupees on expiry of 90 days after the discharge of the obligations under the contract.
- 2.4 Failure to furnish correct and detailed information as called for in paragraph 2.0 above will render the concerned tender liable to rejection or in the event of a contract materializing, the same liable to termination by BHEL. Besides this there would be a penalty of banning business dealings with BHEL or damage or payment of a named sum.

---X---

Annexure-B

This format is applicable only to Indian Suppliers/ Agents supplying indigenous portion of Foreign Purchases.

\* In all other cases, extant guidelines of SEARP, 2010 are to be followed.

SEARP (SRF) Clause No	Detail
	<b>Name &amp; address of the firm</b>
<b>1.0</b>	<b>Products/ Systems / Services being considered for</b>
<b>2.0</b>	<b>General Information</b>
2.2	Name of Chief Executive
2.3	Details of authorized signatory
<b>3.0</b>	<b>Ownership Information</b>
3.1	Type of firm
3.2	Nature of Business <ul style="list-style-type: none"> <li>• <i>Attach <b>authorization letter</b> and <b>agency agreement</b> from Principal ( from whom capital equipment is procured)</i></li> <li>• <i>Attach copy of declaration from Foreign Principal for <b>total guarantee/ warranty of indigenous supplies</b></i></li> </ul>
3.3	Year of establishment
3.4	Year of commencement of business
<b>4.0</b>	<b>Registration particulars</b>
4.1	Permanent Account No.
4.2 / 4.3	Sales Tax / TIN no
4.6	Service tax no. (in case of E&C)
<b>5.0</b>	<b>Organisational strength</b>
<b>6.0</b>	<b>Other particulars</b>
6.1	If the company is already registered with other units
6.2	Directors/ Partners, if related to any BHEL Employee
6.9	If any Ex BHEL Personnel employed by the Company
6.12	Details of pending legal issues with BHEL
6.13	Bank Account information
<b>9.0</b>	<b>Financial information</b>
9.6	Sales/ Turnover details of last 3 years (or from the date of incorporation whichever is less )

---X---