



ISO  
9001:2008  
&14001:2004  
NAVARATNA  
COMPANY

MATERIAL MANAGEMENT (PURCHASE)  
CENTRAL FOUNDRY FORGE PLANT, BHEL HARDWAR  
RANIPUR, HARIDWAR (INDIA) – 249403  
Phone No.01334-281277/285635, FAX No. 01334-225892  
e-mail :ranjank@bhelhwr.co.in,  
rohit\_v@bhelhwr.co.in,v\_kumar@bhelhwr.co.in

Sub: Tender Enquiry No: 4005P/920/3/0269Q1 Dt. 16.10.2013 due on 18.11.2013.

Dear Sir,

We are pleased to invite offer as per enclosed specification with terms and conditions in sealed envelop for the under mentioned material.

Sl No	Tender No	Description of Material	Qty	Date & Time of Tender Opening
01	4005P/920/3/0269Q1	FF8121071267 60 T ROTATING HANGER FOR VERTICAL QUENCHING OF LONG FORGINS SIZE : THL-159.	01 NO.	18.11.2013 at 2.00 PM (IST)

Kindly read terms and conditions carefully. Offer not submitted in accordance with the instructions is liable to be disqualified or ignored.

Please visit [www.bhel.com](http://www.bhel.com) or [www.bhelhwr.co.in](http://www.bhelhwr.co.in) for more details and tender documents.

Please also download Supplier Registration Form and submit same dully filled.

Thanking You,

Yours Faithfully,  
For & On behalf of CFFP BHEL Hardwar

(VIPIN KUMAR)  
ENGINEER (Purchase)

Note: Corrigendum if any shall not be published, kindly visit web-site for any changes.



निविदा सूचना  
**TENDER ENQUIRY**

भारत हैवी इलैक्ट्रिकल्स लिमिटेड  
**Bharat Heavy Electricals Ltd**  
सेन्ट्रल फाउन्ड्री फॉर्ज प्लांट- हरिद्वार - २४६४०३ (भारत)  
**Central Foundry Forge Plant, Haridwar-249403 (INDIA)**

Phone : (0091) 01334- 281639,281385,285336

Fax : 01334 225892 / 226458

TIN NO. 05001763485  
C S T NO. HR-5018287 Dt. 16-03-1995

निविदा सूचना सं. ENQUIRY NO.*	4005 P/ 920/3/0269Q1	दिनांक Date	16-10-2013
-------------------------------	----------------------	-------------	------------

कृपया निम्नलिखित के लिए निविदा दें। PLEASE QUOTE FOR THE FOLLOWING :

Office Copy

DUE DATE

18-11-2013

09285 M/s : : :  
: : INDIA

Item Description Quantity Unit Lot Quantity Lot Date

1 FF8121071267 1 NO  
60T ROTATING HANGER FOR VERTIC  
AL QUENCHING OF LONG FORGINGS.

Size - T.H.L - 159

Page No 1

*V. Jain*  
17/10/13

★ महत्वपूर्ण : कृपया कोटेशन देने से पूर्व पीछे दिए गये अनुदेशों को ध्यानपूर्वक पढ़िये।

IMPORTANT : PLEASE READ CAREFULLY THE INSTRUCTIONS GIVEN ON REVERSE BEFORE QUOTING



निविदा सूचना  
**TENDER ENQUIRY**

भारत हैवी इलैक्ट्रिकल्स लिमिटेड  
**Bharat Heavy Electricals Ltd**  
सेन्ट्रल फाउन्ड्री फॉर्ज प्लांट- हरिद्वार - २४६४०३ (भारत)  
**Central Foundry Forge Plant, Haridwar-249403 (INDIA)**

Phone : (0091) 01334- 281639,281385,285336 Fax : 01334 225892 / 226458

TIN NO. 05001763485  
C S T NO. HR-5018287 Dt. 16-03-1995

निविदा सूचना सं. ENQUIRY NO.*	4005 P/ 920/3/0269Q1	दिनांक Date	16-10-2013
-------------------------------	----------------------	-------------	------------

कृपया निम्नलिखित के लिए निविदा दें। PLEASE QUOTE FOR THE FOLLOWING :

Office Copy

SL	MATERIAL CODE	QUANTITY	UNIT	LOTNO	LOT DELIVERY QTY SCHEDULE
----	---------------	----------	------	-------	---------------------------

SIZE: THL- 159.  
DIM.: S.

\*\* IMPORTANT: This enquiry is 2 part tender. Techno-Commercial bid (Part-1) & Price Bids (Part-2) should be submitted in separate envelopes. These two envelopes should be submitted in a common sealed envelope. Techno-Commercial Bid shall contain detailed Technical Specification, Drawings Technical documents, Catalogues, taxes & duties, payment terms, delivery period, Validity of offer, Replica of Price Bid (Copy of price bid without price part) etc. The confirmation to the special terms & conditions must be submitted alongwith Techno-Commercial bid.

Standard Instructions:

TEST CERTIFICATE REQUIRED.  
GUARANTEE CERTIFICATE REQUIRED.  
PRE-INSP AT YOUR WORKS PRIOR DESP.  
BASIC RATES, TAXES DUTIES SEPERATELY  
CENVATABL DUPLICATE COPY OF INVOICE.  
INSP AFTER RECPT AT CFFP.  
ERECTION/COMM REQ AT SITE.

Special Instructions:

1. Submit Annexure A, C & D duly filled, signed & stamped with the offer.
2. Drawing and specification are enclosed.

General Instructions:

1. Please submit authorization letter (format enclosed) for facilitating e-payment/electronic transfer of funds
  2. 100% payment within 30 days after receipt & acceptance of material at CFFP BHEL, Haridwar through e-payment.
  3. CFFP/BHEL RESERVES THE RIGHT TO PRE-INSPECT THE MATERIAL AT VENDOR'S WORKS / GODOWN/ PREMISES BEFORE DESPATCH.
  4. ORIGINAL MANUFACTURER'S TEST CERTIFICATE IS REQUIRED ALONG WITH DESPATCH DOCUMENTS. IN CASE SUPPLIES ARE FROM TRADERS, IT SHALL BE THE RESPONSIBILITY OF THE TRADER TO PROVIDE ORIGINAL MANUFACTURER'S TEST CERTIFICATE WITH LINKAGE TO TRADER'S INVOICE STATING BATCH NO.
  5. CFFP/BHEL Reserves the right to procure from more than one vendor.
  6. Please quote prices in figures & words both. In case the prices quoted in words and figures are different, the values indicated in words will be considered for evaluation & establishing L1 status.
- \* The offers of the bidders who are on the banned list as also the offers of the bidders, who engage the services of the banned firms, shall be rejected. The list of banned firms is available on web site [www.bhel.com](http://www.bhel.com)

Page No

2



*V. Jain*  
17/10/13  
(VIPIN KUMAR)  
Engineer (Pur)

★ महत्वपूर्ण : कृपया कोटेशन देने से पूर्व पीछे दिए गये अनुदेशों को ध्यानपूर्वक पढ़िये।

IMPORTANT : PLEASE READ CAREFULLY THE INSTRUCTIONS GIVEN ON REVERSE BEFORE QUOTING

	<p>संस्थान क्रय विनिर्देश (सी.एफ.एफ.पी-हरिद्वार) PLANT PURCHASE SPECIFICATION (CCEP - HARDWAR)</p>	FF-04052 Rev01		
		पृष्ठ	6	का
		Page	1	of 6

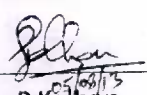
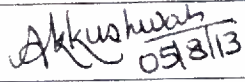
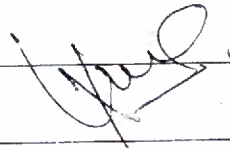
TECHNCIAL SPECIFICATION  
OF  
60T ROTATING DEVICE

 P Kalhan (Sr. Engr., Forge Shop)	 A K Kushwah (Mgr., Forge)	 N Kumar (Sr. Mgr, M&S)	 G M Verma (AGM, Forge)
--	---	---	--

5



संस्थान क्रय विनिर्देश  
 (सी.एफ.एफ.पी-हरिद्वार)  
**PLANT PURCHASE SPECIFICATION**  
 (CFFP - HARDWAR)

FF-04052 Rev01

पृष्ठ 6 का 2  
 Page 2 of 6

S.No.	Description	Vendor's Remarks
1.0	<b>INTRODUCTION:</b> This specification governs the technical and commercial requirement Rotating device for vertical quenching of Rotors suitable up to 60T lifting and rotating capacity for our Vertical Shaft Furnace. The rotor forging temperature will be 1000°C which will be cooled to room temperature in vertical mist quenching unit.	Vendor to Confirm
2.0	<b>VENDOR'S SCOPE OF SUPPLY :</b> The vendor will design, manufacture and supply the Rotating Device as per the specification and drawing therein. Vendor shall visit the site to ensure that the device is suitable to adapt to CFFP furnaces.	Vendor to Confirm
3.0	<b>TECHNICAL REQUIREMENT:</b>	
3.1	Handling capacity of the device should be 60 Ton minimum.	Vendor to Confirm
3.2	The general arrangement drawing of the device will be as per the drawing THL-159 Rev 00. The vendor will furnish the details in the drawing.	Vendor to confirm and submit details
3.3	The 2 numbers supporting brackets should be made of steel and capable of handling the load of weight of rotating device itself in addition to weight of rotor + suspension device( 60T).	Vendor to confirm
3.4	The brackets should be compatible with the 60T Ramshorn hook so that the Rotating device can easily hang in the current 60T Crane.	Vendor to confirm
3.5	The device must be capable for continuous working for approximately 10 Hours.	Vendor to confirm
3.6	<b>Rotation Speed:</b> 6 rpm (Constant).	Vendor to confirm
3.7	<b>Motor:</b> The motor must be of minimum 10HP 4 Pole S4 Crane duty. Only Siemens/ Marathon/ make motor is acceptable.	Vendor to confirm and submit details
3.8	<b>Gear Box:</b> Suitable to hang and rotate rotor in vertical position in vertical mist quenching unit for 10 hours continuously. Rotation should be smooth and noiseless.	Vendor to confirm and submit details
3.9	2 Nos. resting legs of proper size to be provided for the Rotating Device. The drawing to be submitted along with the offer.	Vendor to confirm and submit details
3.10	The device to be equipped with the Forged Ramshorn hook. The hook must be forged and properly heat treated. The Hook shall conform to the latest edition of IS:15560 or any other relevant Indian / International Standard.	Vendor to confirm and submit details

P Kalhan (Sr. Engr., Forge Shop)	A K Kushwah (Mgr., Forge)	N Kumar (Sr. Mgr, M&S)	G M Verma (AGM, Forge)





संस्थान क्रय विनिर्देश  
(सी.एफ.एफ.पी-हरिद्वार)  
**PLANT PURCHASE SPECIFICATION**  
(CFFP - HARDWAR)

FF-04052 Rev01

पृष्ठ 6 का 3

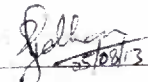
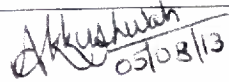

Page 3 of 6

S.No.	Description	Vendor's Remarks
3.11	Vendor must provide all design calculation for the structure including the factor of safety considered and drawings indicating the dimensions.	Vendor to confirm and submit details
3.12	Rotor should hang in the device vertically and hence there shall be balancing arrangement in the Rotation device. To keep Rotor in vertical position and act as counter weight to the gear box.	Vendor to confirm and submit details
3.13	Power cable with pin to be provided with the Rotation device. The power plug will be put in the power socket of crane. The length of the power cable should be at least 5 m.	Vendor to confirm
3.14	All cables should be of copper as per IS standard. Aluminum cables are not acceptable.	Vendor to confirm
3.15	Power Supply: 415V±5%, 50Hz, 3Phase.	Vendor to confirm
3.16	Points for lubrication shall be indicated and cover shall be provided to prevent contamination.	Vendor to confirm and submit details
4.0	<b>GENERAL :</b>	
4.1	Vendor will provide 3 sets of operation and maintenance manual and drawings of the rotating device.	Vendor to confirm
4.2	All relevant calculation to be provided with the offer.	Vendor to confirm and submit details
4.3	Vendor should submit the arrangement drawing mentioning the thickness of plates, motor location, gear box location, Hook etc. for CFFP-BHEL approval.	Vendor to confirm and submit details
4.4	First filling of all required Oils and Grease etc. to be supplied by vendor.	Vendor to confirm
4.5	All electrical/ electronic equipment shall be tropicalized to suit specified ambient and operating conditions.	Vendor to confirm
4.6	All motors shall conform to IEC or Indian standards.	Vendor to confirm
5.0	<b>PRE DISPATCH INSPECTION:</b>	
	Pre-Dispatch inspection shall be carried out by BHEL representative at vendor's works. However it is at the discretion of BHEL and final acceptance testing will be done at CFFP-BHEL. Pre dispatch inspection report by the vendor to be sent to CFFP-BHEL along with the call of inspection.	Vendor to confirm

 P Kalhan (Sr. Engr., Forge Shop)	 A K Kushwah (Mgr., Forge)	 N Kumar (Sr. Mgr, M&S)	 G M Verma (AGM, Forge)
--	---	---	--

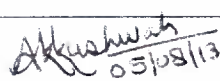

	<b>संस्थान क्रय विनिर्देश</b> <b>(सी.एफ.एफ.पी-हरिद्वार)</b> <b>PLANT PURCHASE SPECIFICATION</b> <b>(CFFP - HARDWAR)</b>	<b>FF-04052 Rev01</b>
		पृष्ठ 6 का 4 Page 4 of 6

SNo.	Description	Vendor's Remarks
6.0	<b>Prove out of BHEL components:</b> Vendor shall demonstrate rotation of 125% of 60T weight (Rotor + Suspension device) i.e 75T at 6rpm speed and for continuously 10 Hours to the full satisfaction of CFFP-BHEL.	Vendor to confirm
7.0	<b>ERECTION AND COMMISSIONING:</b>	
7.1	Supplier to take full responsibility for carrying out the erection, start up, testing of equipment, it's control and all other supplied equipment. Service requirement like crane, power, air & water shall be provided by BHEL at only one point. Details of these requirements should be informed by vendor in advance.	Vendor to confirm
7.2	Tools, Tackles, instruments and other necessary equipment required to carry out erection and commissioning activities to be arranged and brought by the supplier. Out of the complete supply, all tools and tackles etc. which may be required by BHEL to maintain the equipment, after commissioning, shall not be taken back by the vendor.	Vendor to confirm
7.3	Successful proving of the equipment at maximum load by the supplier shall be considered as a part of commissioning.	Vendor to confirm
8.0	<b>Guarantee:</b> Vendor will provide the 18 months guarantee of the equipment after successful erection and commissioning.	Vendor to confirm
9.0	<b>ENVIRONMENT PERFORMANCE OF THE ROTATING DEVICE :</b> The equipment should confirm to the following factors related to environment	
9.1	Maximum noise level shall be 50dB at 1 meter away from the rotation device. Supplier to demonstrate compliance to noise level, if asked for.	Vendor to confirm
9.2	There shall be no emission from the equipment.	Vendor to confirm
9.3	There shall be no effluent from the equipment	Vendor to confirm
9.4	If any/ safety environment protection enclosure is required it should be built in the equipment by the vendor.	Vendor to confirm
9.5	Paint of the equipment should be oil resistant and should not get peel off. Extra paint to be provided to remove any scratch, if any. Color : Golden Yellow with Black strips.	Vendor to confirm
10.0	<b>Weather conditions</b> are tropical. Atmosphere will be mist/ moisture and dust laden during working. Equipment shall be kept in the normal shop floor condition. Vendor should confirm that equipment is suitable for above details of provision on the equipment for the same to be furnished by vendor.	Vendor to confirm

 <b>P Kalhan</b> (Sr. Engr., Forge Shop)	 <b>A K Kushwah</b> (Mgr., Forge)	 <b>N Kumar</b> (Sr. Mgr, M&S)	 <b>G M Verma</b> (AGM, Forge)
---	--	--	---

	संस्थान क्रय विनिर्देश (सी.एफ.एफ.पी-हरिद्वार) <b>PLANT PURCHASE SPECIFICATION</b> (CFPP - HARDWAR)	<b>FF-04052 Rev01</b>
		पृष्ठ 6 का 5 Page 5 of 6

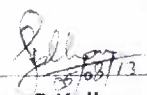
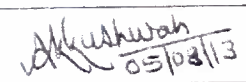
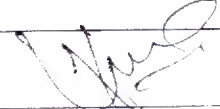
SNO.	DESCRIPTION	VENDOR'S REMARKS
11.0	PACKING :	
	Suitable packing for all items of complete equipment, all accessories and other supplied items to avoid any damage/ loss during transit.	Vendor to confirm
12.0	PREQUALIFICATION CRITERIA :	
12.1	The vendor must have designing and fabrication capabilities for manufacture of load handling/ Rotating equipments. The vendor must have supplied at least one no. 50T Load handling equipment in last 7 years (on the date of opening of Tender) and it is running successfully from last 2 years (on the date of opening of Tender). Following details have to be submitted with the offer	Vendor to confirm
12.2	Supplied equipment details	Vendor to submit
12.3	Name of the customer/ company where referred equipment is installed.	Vendor to submit the details
12.4	Complete postal address of the customer.	Vendor to submit the details
12.5	Month and year of commissioning. (DD/ YYYY)	Vendor to submit the details
12.6	Name and designation of the contact person of the above customer.	Vendor to submit the details
12.7	Phone, Fax no. and e-mail address of the contact person of the above customer.	Vendor to submit the details
12.8	Performance certificate from the customer regarding satisfactory performance of the equipment supplied to them (original Certificate through e-mail directly from the customer) or the vendor should submit the Original Certificate. The Original Certificate will be returned to vendor after verification.	Vendor to submit the details
	BHEL reserves the right to verify the information submitted by vendor including visit to the vendor's works and witnessing the manufacturing & operational procedures. <b>In case information found to be false/ incorrect, the offer shall be rejected.</b>	Vendor to accept & confirm

 P Kalhan (Sr. Engr., Forge Shop)	 A K Kushwah (Mgr., Forge)	 N Kumar (Sr. Mgr, M&S)	 G M Verma (AGM, Forge)
--	---	---	--

COPYRIGHT AND CONFIDENTIAL  
 THE INFORMATION ON THIS DOCUMENT IS THE PROPERTY OF BHARAT HEAVY ELECTRICALS LIMITED. IT MUST NOT BE USED DIRECTLY OR INDIRECTLY IN ANY WAY DETERIMENTAL TO THE INTEREST OF THE COMPANY.

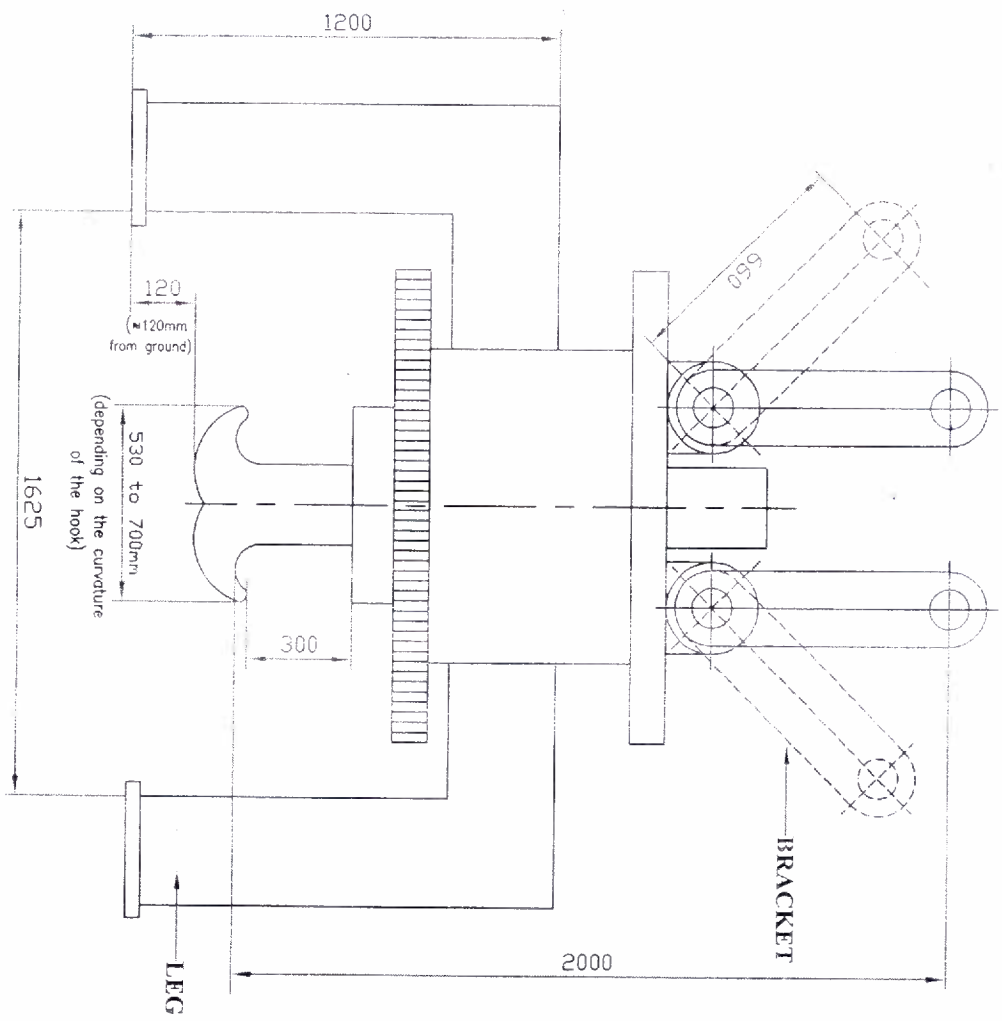

651 - THI ON SWAMPID

FIRST ANGLE PROJECTION

ALL DIMENSIONS ARE IN mm.

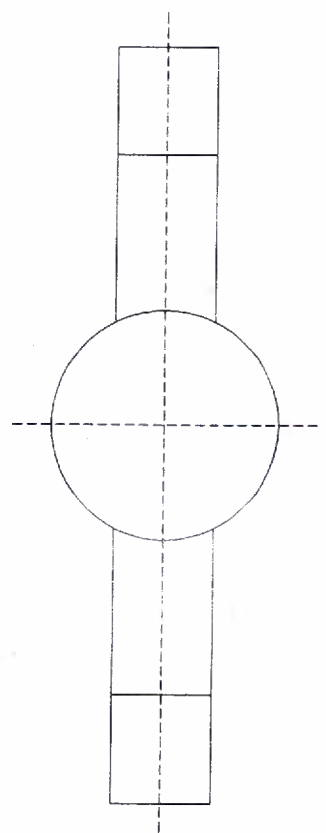

 BHARAT HEAVY ELECTRICALS LIMITED RANIPUR, HARDWAR		DEPTT. FORCE SHOP CODE 920		SCALE		WEIGHT (KG) 63 Kg		REVISIONS DRAWING NO.	
DRN	P. KALHAN	NAME		MATERIAL		DATE		REV	
CHD	MD. SHAMEEM	SGN.							
APPD	A. K. KUSHWAH	DATE	02/07/13						
		DATE	5/8/13						

ROTATING DEVICE FOR TURBINE ROTOR  
 (HT)

THL-159

01

01

A3 SIZE

Name of Vendor:.....

Annexure : A201302691

Evaluation shall be done on the basis of delivered cost (i.e.) "total cost to BHEL". Confirmation/comments on the conditions given below are mandatory. Please confirm the following or else your offer is liable to be rejected.

	Description	Vendor Confirmation /Comment (In case of blank, it shall be deemed to be accepted by vendor)
1	Guarantee Certificate (as per specification/enquiry) shall be provided along with despatch documents.	
2	Please specify whether you are a manufacturer or a trader of this material	
3	Original Manufacturer's Test Certificate shall be provided along with despatch documents.	
4	Pre Despatch inspection shall be carried out by CFFP BHEL at supplier works.	
5	Final inspection shall be carried out after receipt of material at CFFP.	
6	Delivery shall be made on FOR Destination basis, destination being Stores/CFFP/BHEL Haridwar, Freight & Insurance charges to vendor's account.	
7	CFFP Reserves the right to open the price bid through Reverse Auction. Confirm your acceptance / participation.	
8	Payment Term: For indigenous suppliers: 100% within 30 days after receipt & acceptance of material at CFFP / BHEL, Haridwar through e-payment. For foreign suppliers: Payment through USANCE LC on 70 <sup>th</sup> day of bill of lading date. All bank charges shall be to vendor's account.  * In case vendor does not agree, proper loading shall be done	
9	Validity of offer: Minimum 120 days from tender opening date. Offers with validity less than 120 days may not be considered.	
10	Prices shall be firm till execution of Order	
11	Liquidated damage : The delivery of the goods shall be made strictly as per time limit specified in delivery schedule of purchase order, failure to supply within this period will make the supplier liable to penalty of 1/2 (half) percent of the price of the goods in arrears per week subject to a maximum of 10%.	
12	Provide name, mobile no. & email address of the contact person	
13	In case vendor is not registered with CFFP BHEL Haridwar for this material, duly filled up "Supplier Registration Form" must be submitted with techno-commercial bid (form available on website <a href="http://www.bhelhwr.co.in">www.bhelhwr.co.in</a> & <a href="http://www.bhel.com">www.bhel.com</a> ). If duly filled SRF is not received within 15 days of opening of techno commercial bid, offer will not be considered for price bid opening.	
14	Delivery Schedule : 90 days from PO date	
15	Operation and Maintenance manual required	
16	In case of any difference observed in conditions confirmed above & elsewhere in the offer, terms quoted above shall be treated as final and binding on vendor.	

Date:

Signature with Seal of the Company

GENERAL TERMS AND CONDITIONS OF TENDER ENQUIRY  
ANNEXURE-B

01 Submit the tender in two parts i.e.

- Part-I Techno-Commercial Bid**  
**Part-II Price Bid**

Techo - Commercial (part one) Price Bid (part two) should be put in separate sealed envelopes. Both envelopes should be super scribed with **Tender Number, Date of opening & Technical / Commercial Bid and Price Bid** respectively along with name of firm.

Both the envelopes i.e. containing Techno-Commercial Bid and Price Bid should again be kept in one envelope super scribed again with Tender No. and Date of opening and the name of firm submitting the tender and send it to **AGM (MM), Purchase Department, CFFP/BHEL, Hardwar, Ranipur, Hardwar 249403, Uttarakhand, India before due date / tender opening date & time**. Normally tender opening time is 2.00 PM on due date or as mentioned in enquiry.

**Responsibility for submission of tender in time solely lies with vendor. Late offers received after specified time / Date shall not be considered.**

1. Part-I Envelopes super scribed with **Techno-Commercial Bid** must contain all information especially-
  - (a) Specification of the material offered should be strictly as per CFFP/BHEL specifications of enquired material in tender documents **Deviations if any must be indicated clearly in the offer. Rates to be quoted on For Destination Basis.**
  - (b) All commercial terms i.e. packing, forwarding Custom duty, Additional Duty, ST/STT/VAT/CST, Excise Duty/CVD, Bank charges, payment terms & insurance etc as applicable (**except price**) should be clearly mentioned in Techno-Commercial bid. Also mention present rate of applicable taxes & duties even if inclusive in rates along with the concessional forms required if any.
  - (c) Confirm to submit all required commercial documents (tax invoice centvatable duplicate copy of invoice, packing list, transit sale agreement etc.) & technical documents (TC/GC/QP etc).
  - (d) Registration Numbers of SSI, Central Excise, Sales tax, Income Tax, DGS & D.ECC etc.
  - (e) **Un-priced copy of Price Bid.**

Part-II Envelopes super scribed with **Price Bid** should contain priced copy of Price Bid. The price should be mentioned both in figures and words.

2. Authorized Signatory should authenticate all tender documents.
3. **Techno-commercial bid (Part-I)** will be opened on the due date at 2.00 PM in the presence of participating vendors or authorized representatives, who may wish to be present. Representative deputed to witness tender opening must produce an authority letter from the signatory of offer. After evaluation of technical bids & finalization of technical, commercial terms & conditions, price bid of only successful vendors will be opened. Priced bid opening date shall be intimated separately.
4. The material offered must conform to the required BHEL specifications and drawings as well as instructions and details made available.
5. For new vendors, Vendor Registration form duly filled must be submitted along with the offer which can be downloaded from our web site [www.bhel.com](http://www.bhel.com) or [www.bhelhwr.co.in](http://www.bhelhwr.co.in).
6. Original manufacturer's Test Certificate is required along with dispatch documents. In case supplies are from traders, it shall be the responsibility of the trader to provide original manufacture's test certificate with linkage to traders invoice stating batch no.
7. **Validity** of offers should be minimum 90 working days from the date of tender (Techno-Commercial Bid) opening.

8. **Delivery** in the promised period is the essence of contract. Confirm to supply according to delivery schedule mentioned.
9. **Payment terms:**  
For indigenous suppliers: 100% within 30 days after receipt & acceptance of material at CFFP / BHEL, Haridwar through e-payment.  
For foreign suppliers: Payment through USANCE LC on 70<sup>th</sup> day of bill of lading date. All bank charges shall be to vendor's account.
- \* in case vendor does not agree, proper loading shall be done. Also in that case, third party inspection shall have to be arranged by supplier from any of the five inspection agencies namely: LRS/ BVQI/ DNV/ TUV/ Alfred H Knight at their cost.
10. CFFP/BHEL, Hardwar reserves the right to accept or reject any or all tenders without assigning any reason thereof.
11. Tenders not submitted in the prescribed manner are likely to be ignored / rejected.
12. Agent/Agency Commissioning: Payment of any kind at any stage will not be made to agent on account of agent commission or otherwise by CFFP/BHEL, Hardwar.
13. CFFP/BHEL, Hardwar may opt for E-auction/Reverse auction for obtaining best prices for part or full tendered quantity. BHEL also reserve the right to negotiate price with L1 vendor after reverse auction.
14. Please do intimate the personal contact details like Name, Mobile Number, Email-id etc of authorized executive for correspondence.
15. **Penalty:** Orders placed against this enquiry will be subject to normal clauses for imposing penalty. Liquidated Damages, Risk purchases, cancellation, arbitration as per terms and conditions of Tender Enquiry and Purchase orders in case of delay in effecting supply and/ or other defaults.  
**Liquidated damage:** The delivery of the goods shall be made strictly as per time limit specified in delivery schedule, failure to supply within this period will make the supplier liable to an conditional penalty of 1/2 (half) percent of the price of the goods in arrears per week subject to a maximum of 10%.
16. **Inspection:** Final inspection of material shall be done after receipt of material at CFFP/BHEL, Hardwar. Acceptance of material shall be after final inspection and shall be binding. However, CFFP reserves the right to pre Inspect the material at supplier works. In case material is found defective during warranty period, the same will be returned for repair and/ or replacement. For this vendor has to bear all the charges such as Freight, to and fro insurance etc. Bank Guarantee for the equal amount to the cost of the item is to be furnished by vendor. In case the repair is done at CFFP/BHEL the amount on actual shall have to be reimbursed by the Vendor and or adjusted on actual from their bill.
17. **Currency of Payment:** Mention the currency in which payment has to be made. For evaluation of price bids, exchange rate (TT selling rate of SBI) as on scheduled date of tender opening (Part-1 bid in case of two part bid) shall be considered.
18. Traders should submit authorization letter from their principal alongwith offer.
19. Disputes: In event of any dispute arising out of contractual obligation, the order being finalized at Hardwar, India will be subject to Indian Laws and falls under jurisdiction of the court of Law at Haridwar, India. The overseas supplier hereafter referred to as "Vendor" shall therefore abide by the verdict of Court of Law at Hardwar, India.  
OR  
All disputes arising out of or in connection with the present contract, if any shall be finally settled under the rules of arbitration of International chamber of commerce by one or more arbitrator appointed in accordance with the said Rules in India.
20. BHEL reserves the right to place P.O. for part / full qty and on one or more than one sources.
21. Any Term & condition of the specific tender (if specified in tender & contradicts with above term) will supersede the above general terms & conditions.

Confirmation/comments on the conditions given below are mandatory. Please confirm the following or else your offer is liable to be rejected.

S.No.	Description	Vendor Confirmation /Comment (In case of blank, it shall be deemed to be accepted by vendor)
1.0	<b>Introduction:</b> This specification governs the technical and commercial requirement Rotating device for vertical quenching of Rotors suitable up to 60T lifting and rotating capacity for our Vertical Shaft Furnace. The rotor forging temperature will be 1000°C which will be cooled to room temperature in vertical mist quenching unit.	
2.0	<b>Vendor's Scope Of Supply:</b> The vendor will design, manufacture and supply the Rotating Device as per The specification and drawing therein. Vendor shall visit the site to ensure that the device is suitable to adapt to CFFP furnaces.	
	<b>Technical Requirements:</b>	
3.1	Handling capacity of the device should be 60 Ton minimum.	
3.2	The general arrangement drawing of the device will be as per the drawing THL-159 Rev 00. The vendor will furnish the details in the drawing.	
3.3	The 2 numbers supporting brackets should be made of steel and capable of handling the load of weight of rotating device itself in addition to weight of, rotor + suspension device( 60T).	
3.4	The Rotating brackets should be compatible with the 60T Ramshorn hook so that the device can easily hang in the current 60T Crane.	
3.5	The device must be capable for continuous working for approximately 10 Hours.	
3.6	Rotation Speed: 6 rpm (Constant).	
3.7	<b>Motor:</b> The motor must be of minimum 10HP 4 Pole S4 Crane duty. Only Siemens/ Marathon/ make motor is acceptable	
3.8	<b>Gear Box:</b> Suitable to hang and rotate rotor in vertical position in vertical mist quenching unit for 10 hours continuously. Rotation should be smooth and noiseless.	
3.9	2 Nos. resting legs of proper size to be provided for the Rotating Device. The drawing to be submitted along with the offer.	
3.10	The device to be equipped with the Forged Ramshorn hook. The hook must be forged and properly heat treated. The Hook shall conform to the latest edition of IS: 15560 or any other relevant Indian / International Standard.	
3.11	Vendor must provide all design calculation for the structure including the factor of safety considered and drawings indicating the dimensions.	
3.12	Rotor should hang in the device vertically and hence there shall be balancing arrangement in the Rotation device. To keep Rotor in vertical position and act as counter weight to the gear box.	
3.13	Power cable with pin to be provided with the Rotation device. The power plug will be put in the power socket of crane. The length of the power cable should be at least 5 m.	
3.14	All cables should be of copper as per IS standard. Aluminum cables are not acceptable.	
3.15	<b>Power Supply:</b> 415V±5%, 50Hz, 3Phase.	
3.16	Points for lubrication shall be indicated and cover shall be provided to prevent contamination.	
	<b>General Requirements</b>	
4.1	Vendor will provide 3 sets of operation and maintenance manual and drawings of the rotating device.	
4.2	All relevant calculation to be provided with the offer.	
4.3	Vendor should submit the arrangement drawing mentioning the thickness of plates, motor location, gear box location, Hook etc. for CFFPBHEL approval.	
4.4	First filling of all required Oils and Grease etc. to be supplied by vendor.	

4.5	All electrical/ electronic equipment shall be tropicalized to suit specified ambient and operating conditions.	
4.6	All motors shall confirm to IEC or Indian standards.	
5.0	<b>Pre Dispatch Inspection:</b> Pre-Dispatch inspection shall be carried out by BHEL representative at vendor's works. However it is at the discretion of BHEL and final acceptance testing will be done at CFFP-BHEL. Pre dispatch inspection report by the vendor to be sent to CFFP-BHEL along with the call of inspection.	
6.0	<b>Prove out of BHEL components:</b> Vendor shall demonstrate rotation of 125% of 60T weight (Rotor + Suspension device) i.e 75T at 6rpm speed and for continuously 10 Hours to the full satisfaction of CFFP-BHEL.	
	<b>Erection And Commissioning:</b>	
7.1	Supplier to take full responsibility for carrying out the erection, start up, testing of equipment. Its control and all other supplied equipment. Service requirement like crane, power, air & water shall be provided by BHEL at only one point. Details of these requirements should be informed by vendor in advance.	
7.2	Tools, Tackles, instruments and other necessary equipment required to carry out erection and commissioning activities to be arranged and brought by the supplier. Out of the complete supply, all tools and tackles etc. which may be required by BHEL to maintain the equipment, after commissioning, shall not be taken back by	
7.3	Successful proving of the equipment at maximum load by the supplier shall be considered as a part of commissioning.	
8.0	<b>Guarantee:</b> Vendor will provide the 18 months guarantee of the equipment after successful erection and commissioning.	
9.0	<b>Environment Performance Of The Rotating Device:</b> The equipment should confirm to the following factors related to environment	
9.1	Maximum noise level shall be 50dB at 1 meter away from the rotation device. Supplier to demonstrate compliance to noise level, if asked	
9.2	There shall be no emission from the equipment.	
9.3	There shall be no effluent from the equipment	
9.4	If any/ safety environment protection enclosure is required it should be built in the equipment by the vendor	
9.5	Paint of the equipment should be oil resistant and should not get peel off. Extra paint to be provided to remove any scratch, if any. Color : Golden Yellow with Black strips	
10.0	<b>Weather conditions</b> are tropical. Atmosphere will be mist/ moisture and dust laden during working. Equipment shall be kept in the normal shop floor condition. Vendor should confirm that equipment is suitable for above details of provision on the equipment for the same to be furnished by vendor	
11.0	<b>Packing:</b> Suitable packing for all items of complete equipment, all accessories and other supplied items to avoid any damage/ loss during transit.	

Date:

Signature with Seal of the Company

**ANNEXURE: D 201302691 PRE QUALIFICATION CRITERIA**

Name of Vendor:.....

Confirmation/comments on the conditions given below are mandatory. Please confirm the following or else your offer is liable to be rejected.

S.No.	Description	Vendor Confirmation /Comment (In case of blank, it shall be deemed to be accepted by vendor)
1	The vendor must have designing and fabrication capabilities for manufacture of load handling/ Rotating equipments. The vendor must have supplied at least one no. 50T Load handling equipment in last 7 years (on the date of opening of Tender) and it is running successfully from last 2 years (on the date of opening of Tender). Following details have to be submitted with the offer	
2	Supplied equipment details	
3	Name of the customer/ company where referred equipment is installed.	
4	Complete postal address of the customer.	
5	Month and year of commissioning. (DD/ YYYY)	
6	Name and designation of the contact person of the above customer	
7	Phone, Fax no. and e-mail address of the contact person of the above customer.	
8	Performance certificate from the customer regarding satisfactory performance of the equipment supplied to them (original Certificate through e-mail directly from the customer) or the vendor should submit the Original Certificate. The Original Certificate will be returned to vendor after verification. BHEL reserves the right to verify the information submitted by vendor including visit to the vendor's works and witnessing the manufacturing & operational procedures. In case information found to be false/ incorrect, the offer shall be rejected.	

Date:

Signature with Seal of the Company

**Terms and conditions regarding Indian agent of foreign suppliers:**

01. BHEL shall deal directly with foreign vendors, wherever required, for procurement of goods. However, if the foreign principal desires to avail of the services of an Indian agent, then the foreign principal should ensure compliance to regulatory guidelines- which require mandatory submission of an Agency agreement.
02. It shall be incumbent on the Indian agent and the foreign principal to adhere to the relevant guidelines of Government of India, issued from time to time.
03. The agency agreement should specify the precise relationship between the foreign OEM/Foreign principal and their Indian agent and their mutual interest in the business. All services to be rendered by agent/associate, whether of general nature or in relation to the particular contract, must be clearly stated by the foreign supplier / Indian agent. Any payment, which the agent or associate receives in India or aboard from the OEM, whether as commission or as a general retainer fee should be brought on record in the agreement and be made explicit in order to ensure compliance to laws of the country.
04. Any agency commission to be paid by BHEL to the Indian agent shall be in Indian currency only.
05. Tax deduction at source is applicable to the agency commission paid to the Indian agent as per the prevailing rules.
06. In the absence of any agency agreement, BHEL shall not deal with any Indian agent (authorized representatives/ associate/consultant, or by whatever name called) and shall deal directly with the foreign principal only for all correspondence and business purposes.
07. The "Guidelines for Indian Agents of Foreign Suppliers" enclosed at annexure- 'A' shall apply in all such cases.
08. The supply and execution of the Purchase Order (including indigenous suppliers/service) shall be in the scope of the OEM/ Foreign principal. The OEM/ Foreign principal should submit their offer inclusive of all indigenous suppliers/services and evaluation will be based on 'total cost to BHEL'. In case OEM/ foreign principal recommends placement of order(s) towards indigenous portion of supplies/services on Indian Supplier (s)/ agent on their behalf, the credentials/capacity/capability of the Indian Supplier (s)/ agent to make the supplies/Services shall be checked by BHEL as per the extant guidelines of Supplier Evaluation, Approval and Review Procedure (SEARP), before opening of price bids. In this regards, details may be checked as per Annexure- 'B' (copy enclosed). It will be the responsibility of the OEM/ Foreign Principal to get acquainted with the evaluation requirements of Indian supplier/agent as per SEARP available on [www.bhel.com](http://www.bhel.com).

The responsibility for successful execution of the contract (including indigenous supplies/services) lies with the OEM/ foreign principal. All bank guarantees to this effect shall be in the scope of the OEM/Foreign principal.

**Guidelines for Indian Agents of Foreign Suppliers**

- 1.0 There shall be compulsory registration of agents for all Global (Open) Tender and Limited Tender. An agent who is not registered with BHEL shall apply for registration in the registration form in line with SEARP.
  - 1.1 Registered agents will file an authenticated Photostat copy duly attested by a Notary Public/Original certificate of the Principal confirming the agency agreement and giving the status being enjoyed by the agent and the commission/ remuneration/ salary/ retainership being paid by the principal to the agent before the placement of order by BHEL.
  - 1.2 Wherever the Indian representatives have communicated on behalf of their principals and the foreign parties have stated that they are not paying any commission to the Indian agents and the Indian representative is working on the basis of salary or as retainer, a written declaration to this effect should be submitted by the party (i.e. Principal) before finalizing the order.
- 2.0 Disclosure of particulars of agents/ representatives in India, if any.**
- 2.1 Tenderers of Foreign nationality shall furnish the following details in their offers:
    - 2.1.1 The Bidder(s)/ Contractor(s) of foreign origin shall disclose the name and address of the agents/ representatives in India if any and the extent of authorization and authority given to commit the Principals. In case the agent/ representative be a foreign Company, it shall be confirmed whether it is existing Company and details of the same shall be furnished.
    - 2.1.2 The amount of commission/ remuneration included in the quoted price(s) for such agents/ representatives in India.
    - 2.1.3 Confirmation of the Tenderer that the commission/ remuneration, if any, payable to his agents/ representatives in India, may be paid by BHEL in Indian Rupees only.
  - 2.2 Tenderers of Indian Nationality shall furnish the following details in their offers.
    - 2.2.1 The Bidder(s)/ Contractor(s) of Indian Nationality shall furnish the name and address of the foreign principals, if any, indicating their nationality as well as their status, i.e. whether manufacturer or agents of manufacturer holding the Letter of Authority of the Principal specifically authorizing the agent to make an offer in India in response to tender either directly or through the agents/ representatives.
    - 2.2.2 The amount of commission/ remuneration included in the price (s) quoted by the Tenderer for himself.
    - 2.2.3 Confirmation of the foreign principals of the Tenderer that the commission/ remuneration, if any, reserved for the Tenderer in the quoted price(s), may be paid by BHEL in India in equivalent Indian Rupees on satisfactory completion of the Project or supplies of Stores and Spares in case of operation items.
  - 2.3 In either case, in the event of contract materializing, the terms of payment will provide for payment of the commission/ remuneration, if any payable to the agents/ representatives in India in Indian Rupees on expiry of 90 days after the discharge of the obligations under the contract.
  - 2.4 Failure to furnish correct and detailed information as called for in paragraph 2.0 above will render the concerned tender liable to rejection or in the event of a contract materializing, the same liable to termination by BHEL. Besides this there would be a penalty of banning business dealings with BHEL or damage or payment of a named sum.

---X---

## Annexure-B

This format is applicable only to Indian Suppliers/ Agents supplying indigenous portion of Foreign Purchases.

\* In all other cases, extant guidelines of SEARP, 2010 are to be followed.

SEARP (SRF) Clause No	Detail
	<b>Name &amp; address of the firm</b>
1.0	<b>Products/ Systems / Services being considered for</b>
2.0	<b>General Information</b>
2.2	Name of Chief Executive
2.3	Details of authorized signatory
3.0	<b>Ownership Information</b>
3.1	Type of firm
3.2	Nature of Business <ul style="list-style-type: none"> <li>• <i>Attach authorization letter and agency agreement from Principal (from whom capital equipment is procured)</i></li> <li>• <i>Attach copy of declaration from Foreign Principal for total guarantee/ warranty of indigenous supplies</i></li> </ul>
3.3	Year of establishment
3.4	Year of commencement of business
4.0	<b>Registration particulars</b>
4.1	Permanent Account No.
4.2 / 4.3	Sales Tax / TIN no
4.6	Service tax no. (in case of E&C)
5.0	<b>Organisational strength</b>
6.0	<b>Other particulars</b>
6.1	If the company is already registered with other units
6.2	Directors/ Partners, if related to any BHEL Employee
6.9	If any Ex BHEL Personnel employed by the Company
6.12	Details of pending legal issues with BHEL
6.13	Bank Account information
9.0	<b>Financial information</b>
9.6	Sales/ Turnover details of last 3 years (or from the date of incorporation whichever is less)

---X---