

- Note:
1. Lifting hooks should be provided for tank and top plates
 2. Top plate should be fixed with Hex. bolts and nuts
 3. Remove all sharp corners
 4. Material: Mild steel
 5. Oil inlet with Dummy nut and Drain pipe with valve to be welded to tank at suitable place

Item No.	Description	Material	Qty.	Remarks
NAME OF CUSTOMER/PROJECT TYPE OF PRODUCT OR				

		BHARAT HEAVY ELECTRICALS LTD. CORPORATE R&D DIVISION HYDERABAD	
DEPT. MDF	DEPT. CODE 41	SCALE NTS	WEIGHT (KG)
DRN. NAME: K. S. Sai babu DATE: 05-08-14 NO. OF VAR.		CHD. DESIGN: Manish Agrawal APPD. Krishna Dutt REF. TO ASSY. DRG. -N.A.- ITEM NO. -N.A.- NO. OF ITEMS -N.A.-	

TITLE Scale Down Tank 1 (0.4 times)		CARD CODE N.A. SHT. No.	DRAWING NO. QYA 14 015 RD41 01A	NO. OF SHT.
---	--	----------------------------	------------------------------------	-------------

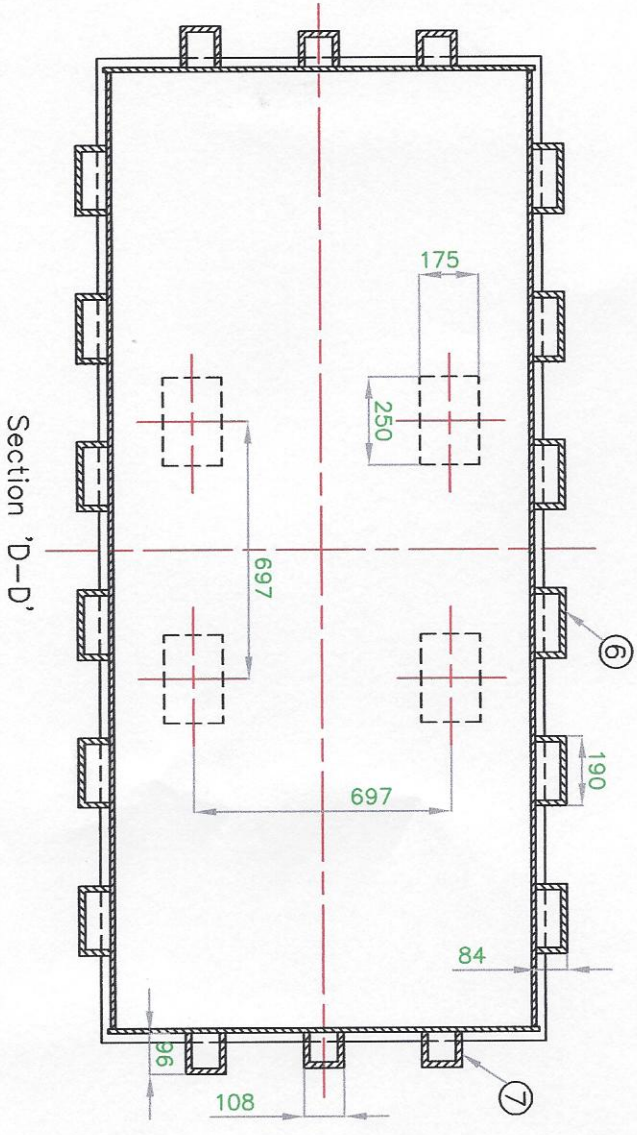
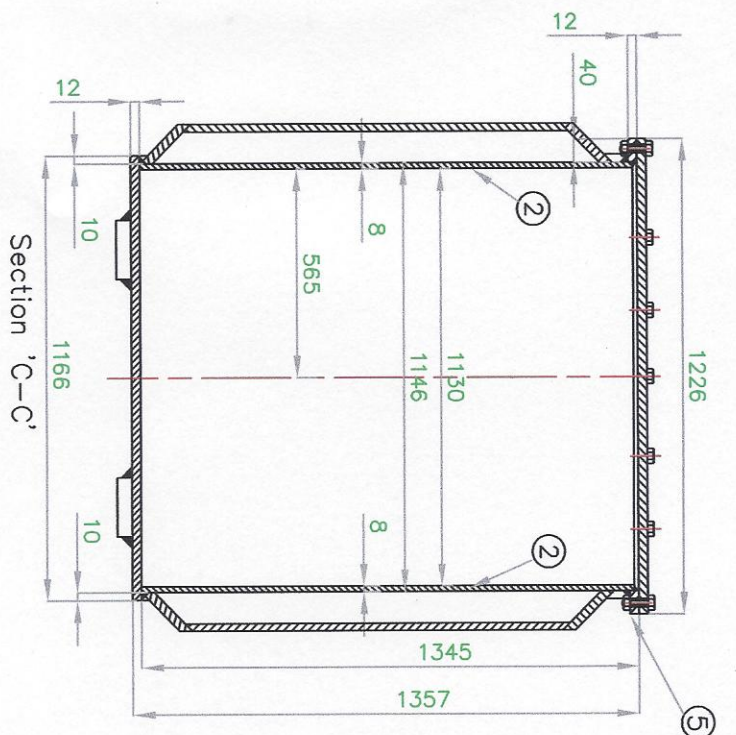

Item No.	Description	Material	Qty.	Remarks

NAME OF CUSTOMER/PROJECT
TYPE OF PRODUCT OR

BHEL BHARAT HEAVY ELECTRICALS LTD.
CORPORATE R&D DIVISION
HYDERABAD

DRN.	NAME	SIGN.	DATE	NO. OF VAR.
	K. S. Sai babu		05-08-14	
DESIGN	CHD.	APPD.	REF. TO ASSY. DRG.	ITEM NO.
	Manish Agrawal			
	Krishna Dutt			

DEPT. MDF	DEPT. CODE	SCALE	WEIGHT (KG)	CARD CODE	DRAWING NO.	NO. OF ITEMS	REV.
41		NTS		N.A.	QYA 14 015 RD41 01B	N.A.	
TITLE					Sectional Drawing for		
Scale Down Tank 1 (0.4 times)							

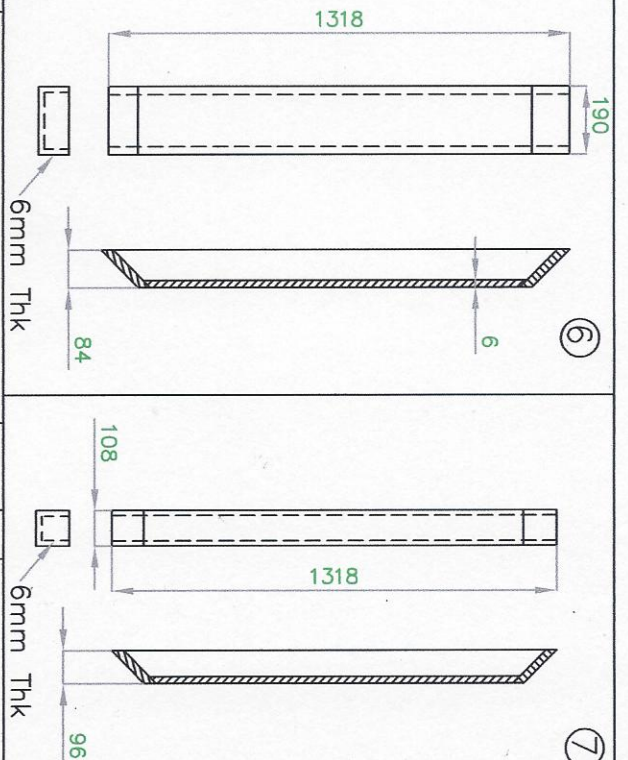
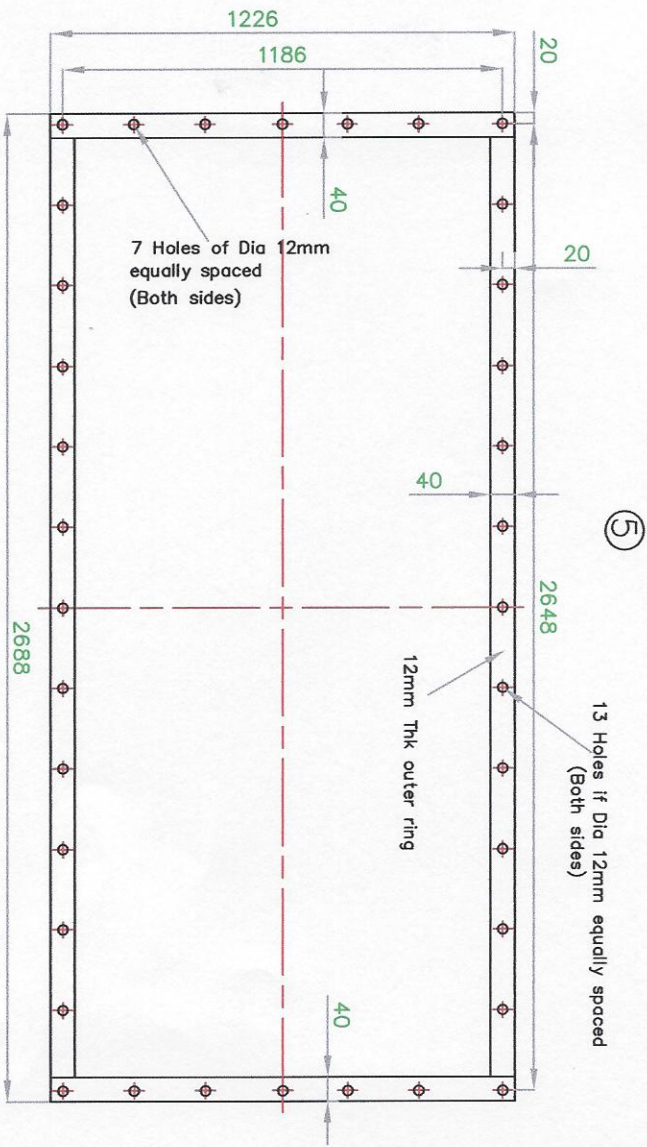
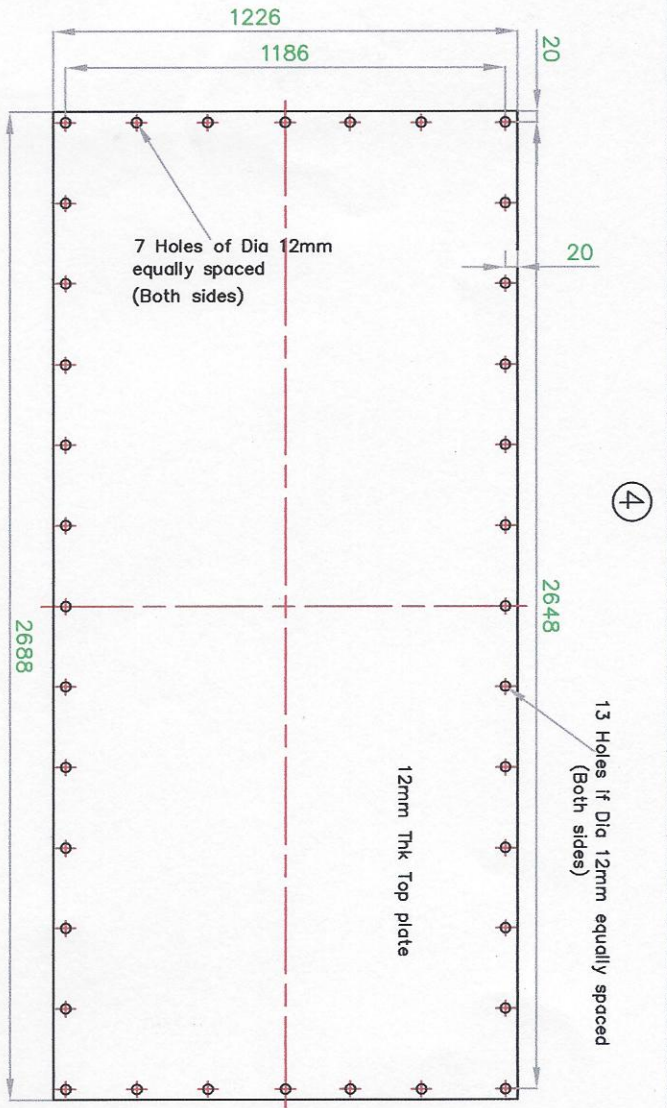

11	1" Drain pipe with Valve				
10	1" Oil inlet pipe with Dummy Nut				
9	M10 Hex. bolt and nut		46		
8	Bottom pads	MS	4		
7	Box Stiffener (Left & Right)	MS	6		
6	Box Stiffener (Front & Back)	MS	12		
5	Outer ring	MS	1		
4	Top plate	MS	1	2688x1226x12 Thk	
3	Side plate (Right & Left)	MS	2	1166x1340x8 Thk	
2	Side Plate (Front & Back)	MS	2	2592x1340x8 Thk	
1	Base plate	MS	1	2628x1166x12 Thk	
Item No.	Description	Material	Qty.	Remarks	

NAME OF CUSTOMER/PROJECT
TYPE OF PRODUCT OR



BHARAT HEAVY ELECTRICALS LTD.
CORPORATE R&D DIVISION
HYDERABAD

DRN.	K. S. Sri babu	NAME	SIGN.	DATE	NO. OF VAR.
DESIGN	Manish Agrawal			05-08-14	
CHD.					
APPD.	Krishna Dutt				
REF. TO ASSY. DRG.		ITEM NO.			

DEPT. CODE	41	SCALE	NTS	WEIGHT (KG)		NO. OF ITEMS	
DEPT.	MDF						

TITLE	CARD CODE	DRAWING NO.	REV.
Part Drawings for	N.A.	QYA 14 015 RD41 01C	
Scale Down Tank 1 (0.4 times)			

SHT. No	NO. OF SHIT.