

The information on this document is the property of BHARAT HEAVY ELECTRICALS LIMITED. It must not be used directly or indirectly in any way detrimental to the interest of the company.

4-13-572-62-30-00
DRAWING No.

First Angle Projection

All dimensions are in MM

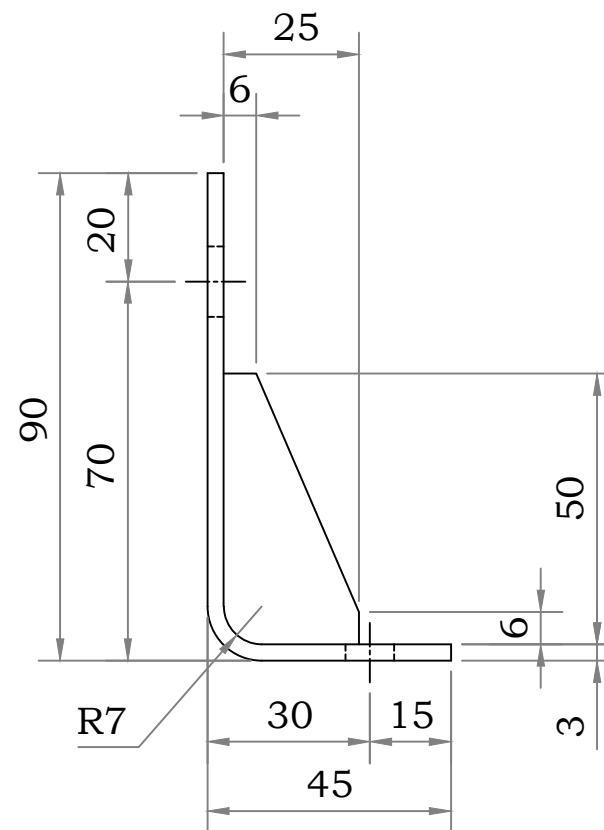
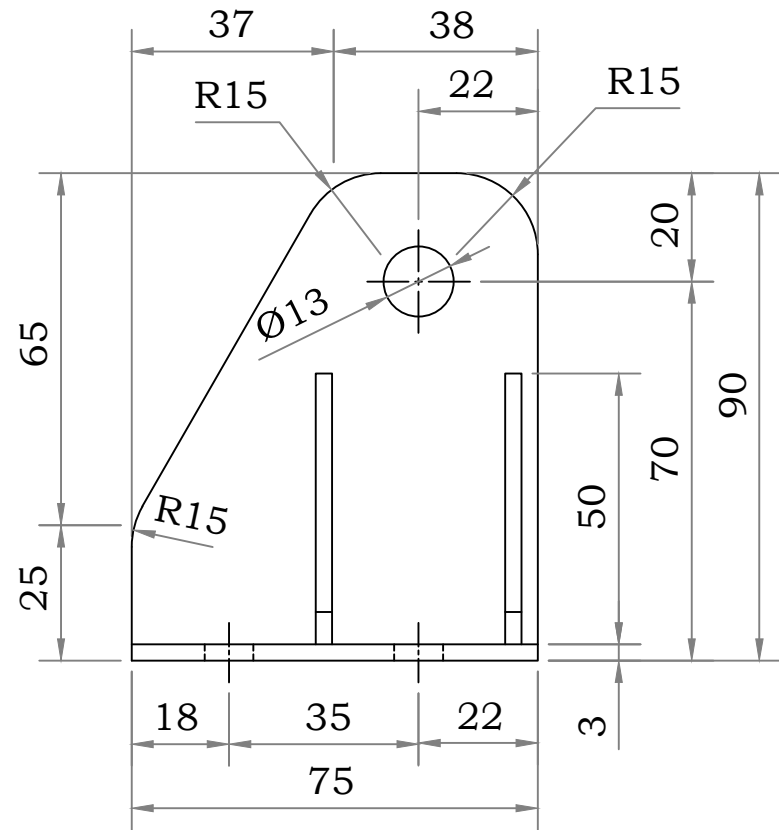

MATERIAL : M.S.
QUANTITY : 72 Nos.

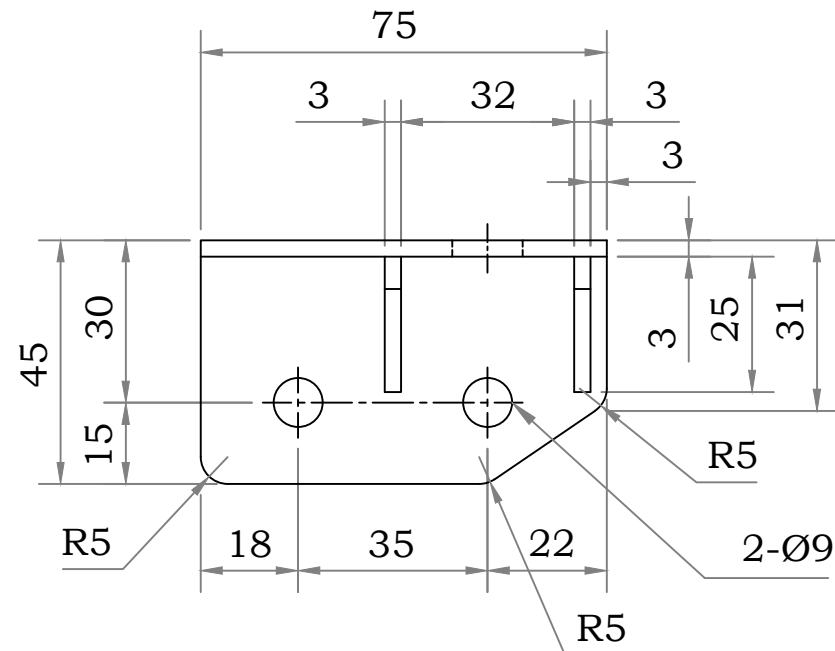

NOTE:

- 1) MATERIAL SHALL BE STRAIGHTENED BEFORE FABRICATION.
- 2) ALL JOINTS ARE TO BE WELDED UNLESS OTHERWISE SPECIFIED.
- 3) SHARP CORNERS/BURRS SHALL BE SMOOTHENED.
- 4) MATERIAL SHALL BE HOT DIP GALVANIZED.

ITEM No.	DESCRIPTION	DRAWING No.	MTL. SPCN. MTL. CODE	QTY.	UNIT WT. (Kg.)
TYPE OF PRODUCT OR NAME OF THE CUSTOMER/PROJECT					
Field Demonstration of 100 kWp SPV System with Solar Thermal Sun Trackers					
BHARAT HEAVY ELECTRICALS LTD. CORPORATE RESEARCH AND DEVELOPMENT			NAME	SIGN	DATE
			DRN	KVPR RAO	
			CKD	SURYA ASP	
			APPD	M R PAWAR	
DEPT FCR CODE 62	MATERIAL M.S.	SCALE NTS	TOTAL WT. (Kg.)	REF. TO ASSY. DRG.	ITEM No. No. OF ITEM
TITLE				DRAWING No.	REV.
FIXED END BRACKET (LEFT) FOR SHOCK ABSORBER (50 kWp HORIZONTAL AXIS PASSIVE TRACKERS)				4-13-572-62-30-00	0
				SHT. No.	No. OF SHTS.